

WHAT'S INSIDE

Welcome
Jon Valin...3

Employee
Vehicle Show...4

Project
Highlights...6

Share Your
Project Photos
for the 2021
Akkerman
Calendar...7

Upcoming
Events &
Conferences...7

Multiple Rock Boring Crossings in Kansas

Southern Star Central Gas Pipeline, Inc. is a Midwest transporter of natural gas with approximately 5,800 miles of transmission pipelines. Consistent with their mission, Southern Star embarked on the \$94.6M Kansas Modernization Project to improve its infrastructure's safety and reliability.

Part of the Kansas Modernization effort, Project C-60266, is a new 36-in. natural gas pipeline between Anderson and Franklin Counties in Kansas.

Minnesota Limited of Big Lake, MN, is the general contractor responsible for 30-miles of open-cut gas pipelines between the two large compressor stations.

Along the pipeline stretch, 30 trenchless crossings with an average length of 120-ft., were to be performed by the HDD method and awarded to The HDD Company of El Dorado Hills, CA. A handful of the longer rock crossings would be completed using the auger-boring method.

When shaft excavations revealed hard rock, The HDD Company enlisted support from their sister-company, The Tunneling Company (TTC) USA, LLC of Yelm WA.

Dane Bergman, General Manager of TTC, explained, "As excavations were opened up, the ground conditions quickly changed the project scope to nearly all rock crossings."

The HDD Company and TTC are subsidiaries of The Crossing Group, headquartered in Nisku, AB. As one of the largest trenchless construction companies in North America, they regularly share expertise and resources to efficiently handle projects of varying complexity.

"Additional equipment and crew were needed to meet the project deadline," Bergman explained, "TTC crew quickly mobilized to Kansas and enlisted the use of a 36-in. Akkerman Rock Boring Unit (RBU) to tackle the additional rock crossings."

The Akkerman RBU is built tough and available in a range of common steel casing diameters for pipeline and infrastructure work. Paired with any manufacturer's auger bore rig or large capacity



Continued from Cover...

guided boring machine, the RBU utilizes 6.5-in. disc cutters, a high capacity main bearing, water-jetting, and muck scrapers to advance through rigorous ground conditions.

The RBU 36 was mated with TTC's 42, 48, and 60-in. auger boring rigs. The crew welded the RBU's outer casing to a lead section of 36-in. steel casing and connected the hex to the auger string.

As the RBU advanced, the disc cutters fractured the rock as the scrapers transferred the material to the auger string. Four adjustable stabilizer pads located around the periphery of the RBU kept the head steady while maintaining alignment.

To assist with material transfer from the RBU cutter head to the auger string, Akkerman applied technology from their other trenchless methods so the operator can introduce jetting-water at this critical zone.

This unique process actively cools the cutter head tooling and bearing assembly resulting in extended performance, reduced wear, and lower operating costs. These features are how TTC completed 16 consecutive drives with the Akkerman RBU without a cutter head rebuild.

Bergman explained, "The head design effectively cleared the clays that typically cause so much trouble for a rock cutting head. We achieved better than anticipated advancement rates through the densest rock that the RBU encountered."

For efficiency, TTC crews set up three crossings with the auger boring rigs. When the Akkerman RBU completed one bore, it was removed from the lead casing, inspected, and installed on the next bore. Often referred to as leapfrogging, crews on

the first bore began tripping augers and installing the final product pipe while the second system commenced boring operations. The three crews worked in tandem to expedite the installations to meet the project deadline. The RBU was used to complete over half of the 30 trenchless crossings on the project

Bergman comments, "The rock varied from clays, shales, broken and sedimentary rock, to almost solid dense rock. It was a rough project, to say the least."

Production rates fluctuated based on the material encountered. The quickest installation was completed in one 12-hour shift and consisted mainly of clay and some rock. The most challenging installation, comprising of high compressive strength rock, was successfully completed in five shifts.

"Overall, the RBU performed well on every crossing it was used on, which echoes the experiences we have enjoyed with our other models of Akkerman RBUs," says Bergman.

TTC crews completed their last rock crossing with the RBU in September 2020.

"The Kansas project was a great opportunity for TTC to use the proven capabilities of the Akkerman RBU in varying and challenging ground conditions," says Bergman. He furthered, "The Akkerman RBU allowed TTC to approach each crossing with confidence."

At the time Akkerman released this article, TTC had finished the trenchless portions of the project as the remaining open-cut pipeline installations were activity installed by Minnesota Limited.



SUBCONTRACTOR: The Tunnelling Company USA, LLC

LOCATION: Ottawa, KS

OWNER: Southern Star Central Gas Pipeline, Inc.

COMPLETION: September 2020 (trenchless work)

GROUND CONDITIONS: Varying Clay and Rock

PIPE: 36-in. steel casing

TOTAL PROJECT: 16 runs

AKKERMAN EQUIPMENT: Rock Boring Unit, Model RBU36

RBU KEY ADVANTAGES

- Use any auger boring machine to install up to 24, 30, 36, 42 and 48-in.* steel casing
- Robust design with high capacity thrust load disc cutters to aggressively fracture rock into cuttings
- Cutter head rock scrapers assist in transferring cuttings away from the face to inlet cavity, to the lead auger for removal
- Fluid connection ports for cooling the bearing assembly for longer life and cleaning the disc cutters in clay/silt ground conditions
- RBUs are inventoried and available for global sales with rental options in North America

Outside Diameter	24, 30, 36, 42, 48-in.*
Ø of Disc Cutters	6.5-in.
No. of Stabilizers	4
Water Jetting	Standard
Length	42-in.
Weight	2,200-5,300 lbs.

Contact us to learn more about our auger boring and guided auger boring solutions for steel casing installations in rock.

*48-in. RBU coming soon!

Welcome Jon Valin

We are pleased to announce the addition of Jon Valin to our sales team as Territory Manager of the Great Lakes Region of North America. Valin has been integrally involved in various aspects of heavy civil construction equipment service and management over the past 20 years.



Valin's career grants him a distinctive perspective. His Akkerman customers will benefit from his experiences of serving many years in the pipeline and trenchless construction industries as an equipment mechanic, and end-user of Akkerman equipment systems.

He also possesses a proven record of project estimating, cost reductions through efficient preventative maintenance practices, production efficiencies that reduced project expenditures, and improved site safety.

Valin began his equipment career with Ziegler Caterpillar, Inc. in Minneapolis, MN as a service technician. He then transitioned to Hoffman Construction, where he managed the business's fleet of equipment and served as a lead mechanic. Following this, he emerged into pipeline construction as a field mechanic.

Mostly recently, Valin held a variety of positions at Michels Corporation including equipment superintendent for their tunneling division.

Valin resides in Greater Milwaukee.

CONTACT JON

m. (262) 225-7566

tf. (800) 533.0386 ext. 0047

d. (507) 539-0047

jvalin@akkerman.com

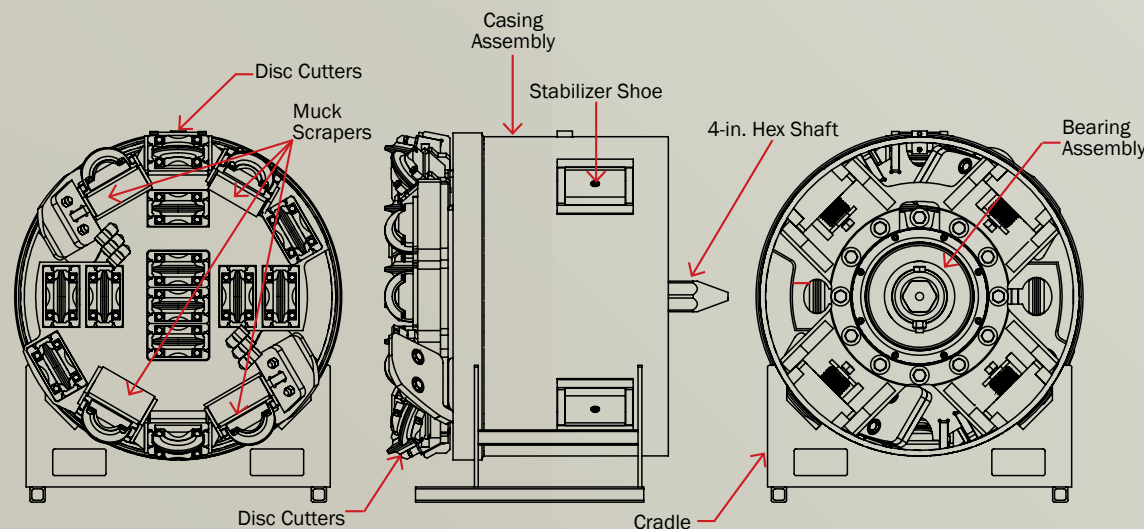

Employee Vehicle Show 2020

When the majority of your employee base consists of mechanically inclined individuals, you know they're going to have some intriguing hobby vehicles.

The inaugural Akkerman Employee Vehicle Show was held during the noon hour on a beautiful fall day in September.

Employees drove or trailered their vehicles that morning, then registered them during the first break in preparation for viewing and voting. The only entry criterion was that the vehicle must be able to be driven.

Participants were competing for the titles of Favorite, Oldest, Loudest, Ugliest, and Most Likely to Get Pulled Over.

Even though only five participants out of nearly 20 entries walked away with a title, everyone was a winner because of the chance to engage with their coworkers through mutual interests.

Continue reading to learn more about our winners' vehicles.

Employee Favorite



1969 CHEVY CHEVELLE SS
Aron Bishop, Production Lead - Machining

"My 1969 Chevelle SS has been in the restoration process for about 10 years. I purchased the car in Sioux Falls, South Dakota and the only remaining original parts are the frame, roof, and trunk lid — everything else had to be replaced due to rust. The car originally came with a 396 big block but that was long gone before I purchased the car. Now it is powered by a 454 big block that my grandfather had in his truck that was given to me after he passed away."

Oldest Vehicle



1966 CHEVY CHEVELLE MALIBU
Keith Kruckeberg, Product Designer

"I owned a 1966 Chevelle when I was in my early 20's, sold it, and always wanted another. So, when I found this one in 2008 near Kenyon, MN, I bought it. I've kept the car pretty much stock except for swapping out the 2-barrel carburetor for a 4-barrel. It has a Powertrain 283 Engine with 4-Barrel Carburetor and Automatic Power Glide Transmission. The paint and interior color is Artesian Turquoise."

Ugliest Vehicle



2000 CHEVY S10
Jason Schlichter, Machinist

"The S10 started life as a nice vehicle to travel in — something to be proud of. After many years of neglect and not much regard for upkeep, it has evolved into the showpiece that you see pictured here. I purchased it for \$150 and then spent some time putting on rear rims, tires, traction bars, and the antennas. I am proud that it won the ugliest award, and looking at it, I think we all could agree. I extend many thanks to my colleagues for seeing this diamond in the rough."

Loudest Vehicle



CHEVY MINI ROD PULLING TRACTOR
Kale Stafford, Mechanic

"Spare Parts is a mini rod pulling tractor that my Dad, uncles and I built in the winter of 2019. It has a V8 engine on an eight-foot-long frame and weighs 1,500 lbs. Tractor pulling at county fairs and events has been a hobby for us for the past five years. It's our way to get away from everyone else. Spare Parts is the only non-legal vehicle in the lineup, and won the loudest award for a 130 decibel rating."

Most Likely To Get Pulled Over



2005 CHEVY SILVERADO
Chase Streiff, Initial Processing and Machinist

"The Chevy is the first truck that I purchased on my own," Steiff reports. On why he won this award he states, "Because of the truck's color, my age, and that I'm one of the newest employees, so I'm an easy target."



Project Highlights



FUEL TRANSFER LINE REPLACEMENT



CONTRACTOR: BRH-Garver Construction LP

LOCATION: Eglin AFB, FL

OWNER: USACE

MICROTUNNEL COMPLETION DATE:
August 2020

GROUND CONDITIONS:
Firm, cemented soil with rock

PIPE: 32-in. Steel casing

TOTAL LENGTH/LONGEST RUN:
3,630-lf./640-lf.

AKKERMAN EQUIPMENT:
SL30C Microtunneling System

BRH-Garver installed 3,630-lf. of 32-in. steel casing by microtunneling for a new Jet Fuel transfer line. The work consisted of seven separate drives installed beneath existing active taxiways and runways used by the USAF 96th Logistics Readiness Squadron. Installation by slurry microtunneling was required by the USACE, to avoid shutting down Airforce operations. This essential project was completed one month ahead of schedule during the COVID-19 pandemic while keeping their crews healthy and productive.

SEWER GROUP 786

CONTRACTOR:
Ortiz Corporation

LOCATION:
Pacific Beach & Mission Bay Area, CA

OWNER:
City of San Diego, CA

COMPLETION DATE: June 2020

GROUND CONDITIONS:
Soft sand and clay

PIPE:
8 & 12-in. ID NO-DIG®
Vitrified Clay Pipe, 1m

TOTAL LENGTH/LONGEST RUN:
3,700-lf./370-lf. of 8-in. ID VCP

AKKERMAN EQUIPMENT:
GBM 240A System

The City of San Diego needed to replace sewer infrastructure in the Pacific Beach and Mission Bay areas. A total of 3,700-lf. was identified for pilot tube guided boring trenchless installation to minimize tourist traffic disruption. The area is home to many beaches, aquatic sports and the Sea World theme park, so continuous highway traffic was a challenge.

The project included the replacement of existing sewer mains applying the following construction methods:

- Rehabilitate approximately 3,700-lf. using pilot tube guided boring trenchless technology at 4 - 21-ft. depths through the median of the main arterial four-lane roadway, and a neighborhood street
- Replace-in-place and realign approximately 11,645-lf. within existing trench alignments via open trenching

The work also included replacement of 50 existing manholes, pedestrian curb ramps, new sewer laterals, and re-plumbing of existing sewer laterals.



The project was initially bid as open-cut construction. In the first seven hundred feet, the soils were so unstable that trench widths reached 15-ft. The soil was also contaminated which required a significant amount of disposal. As costs and social impacts mounted, the owner re-bid the project with the pilot tube guided boring trenchless method encouraged wherever possible.

Challenges

- Tourist area with high levels of traffic
- Contaminated soil
- High level of groundwater, dewatering at 5-50 gpm pumping volumes
- Flat grades ranging from .25 - .75%+

Ortiz crews used a 240A Guided Boring System to install 3,700 lf. of 8 and 12-in. ID VCP in 19 runs with the three-pass method. The solution allowed them to accurately install the pipe in the median while live traffic was continuous alongside the construction zone.

Outcome

- Successful installation of 3,700-lf. of new sewer lines
- Minimized construction impacts
- All line and grade tolerances met
- Reduced construction schedule over original design
- Finished under budget

Share Your Project Photos!

We're collecting project photos for the 2021 Akkerman Calendar!

Your photos should contain Akkerman equipment in good repair as the main subject, on a project that took place between October 1, 2019 and the present.

Please include the following with your emailed photos:

- Contractor's name
- Project Owner
- Project start and end date
- Project name and location
- Akkerman equipment used
- Ground conditions
- Type of installation
- Pipe material, ID/OD, joint length
- Total footage installed & number of drives
- Crew members names and titles (if featured)
- Additional information describing the image or project circumstances

Submit your photos to landerson@akkerman.com by **October 31, 2020** for consideration. If your image is selected, you will be notified and receive 10 copies of the calendar in mid-December.



Visit us at these
2021 Tradeshows &
Conferences:

February 3-6, 2021

27th Annual Pilot Tube Seminar/Microtunneling Short Course
Boulder, CO
University of Colorado Boulder
Sponsor & Presenter

February 4-6, 2021

NUCA 2021 Annual Convention & Exhibit
Naples, FL
Naples Grand Beach Resort
Sponsor & Presenter

March 28 - April 1, 2021

NASTT No-Dig 2021
Booth #817
Orlando, FL
Orange County Convention Center
Exhibitor, Presenter & Gold Sponsor

May 10-11, 2021

Trenchless Technology Road Show
Niagara Falls, ON
Scotiabank Convention Center
Exhibitor & Presenter

May 18-20, 2021

UCT 2021
Booth #528
Nashville, TN
Music City Center
Exhibitor & Presenter

November 8-10, 2021

No-Dig North
Vancouver, BC
Vancouver Convention Centre
Exhibitor & Presenter



Akkerman
58256 266th Street
Brownsdale, MN 55918 | USA

To be removed from our mailing list please email akk@akkerman.com

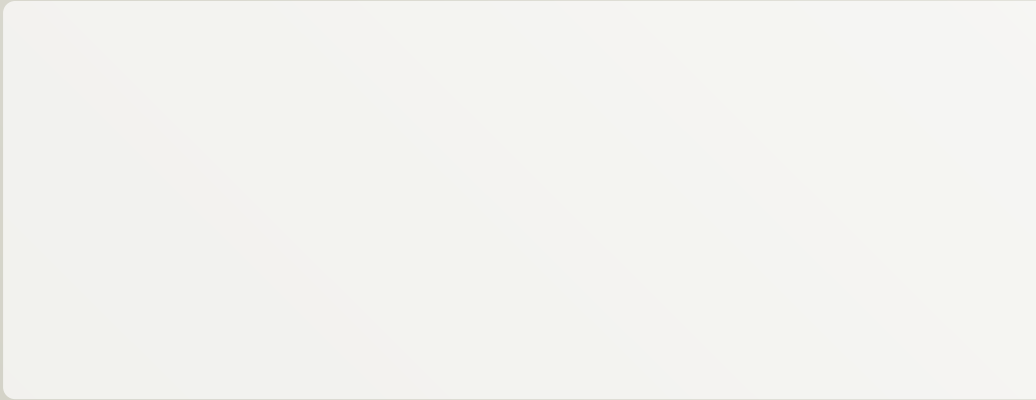

Connect With Us

We invite you to connect with us for updates and unique content as it happens! Please take a moment to like us on Facebook, follow us on Twitter and Instagram, connect with us on LinkedIn, and subscribe to our YouTube channel.

