



OPERATOR'S MANUAL

Guided Boring Machine

4812A S/N: FA40034F

Power Pack SN: P275T (FA40033F) & P150Q (FA40035F)

Powered Cutter Head SN: PCH 20 (FA43100F),

PCH 22.5 (FA42850F), PCH 28.5 (FA43000F),

PCH 36 (FA44400F) & PCH 44 (FA43400F)

Publication No. 050048A

Rev. No. 080128 R101217, 250818

© Akkerman Inc. 2008, 2010, 2025

All Rights Reserved

Akkerman Inc. 58256 266th Street Brownsdale, MN 55918
Phone: 507-567-2261 Fax: 507-567-2605 email: akk@akkerman.com

SERVICE • RELIABILITY • INNOVATION

Introduction

This operator's manual contains important safety, operation, and maintenance information for your Akkerman 4812A Guided Boring Machine (GBM), P275T Power Pack, P150Q Power Pack and Powered Cutter Head. You must read and understand this manual before you operate and maintain this equipment. Keep this manual with your Guided Boring Machine at all times. Additional copies of this manual may be purchased from the Akkerman Product Support Department, or downloaded from the Akkerman web site at www.akkerman.com.

The contractor is responsible for the overall safety program on the job site. Use this manual as a part of the safety program.

The use of second rate parts could affect the efficient performance of the GBM. ALWAYS use genuine Akkerman parts.

Understand safety signal words, DANGER, WARNING, CAUTION, SAFETY INSTRUCTIONS, and NOTICE. When you see these words in this manual or on safety decals mounted on your equipment, follow the safety message to avoid personal injury and/or property damage.

▲ DANGER Indicates an extremely hazardous situation which, if not avoided, WILL result in death or serious injury.

▲ WARNING Indicates a potentially hazardous situation which, if not avoided, COULD result in death or serious injury.

▲ CAUTION Indicates a potentially hazardous situation, which, if not avoided, MAY result in minor or moderate injury. It may also be used to alert against unsafe practices.

SAFETY INSTRUCTIONS Usually consists of individual messages stating procedures or actions that must be followed for the safe operation of a product.

NOTICE Identifies potential property damage and important installation, operator, or maintenance information.

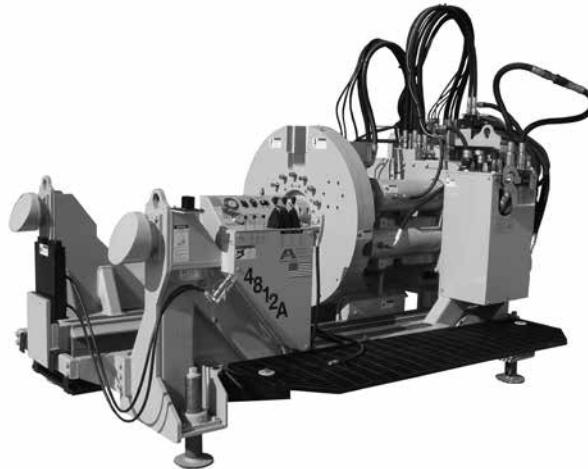

Guided Boring Machine 4812A

The Guided Boring Machine (GBM) installs small diameter pipes with the grade and alignment precision the gravity sewer and water industry demand. The GBM works in conjunction with a specially designed theodolite guidance system to provide extremely accurate pipe installation. Accurate pipeline installation is achieved through video monitor surveillance of an illuminated target via theodolite. Pilot head steering is accomplished by aligning an angled pilot head, or steering head, to the desired course with forward thrust. Pilot tubes are installed behind the steering head. After the steering head has reached the reception shaft, a reaming head and auger tubes with flighting are installed behind the pilot tubes. With the addition of each section of auger tube in the launch shaft, a section of pilot tube is removed in the reception shaft. The process is repeated until all pilot sections have been removed. A pipe adapter is then installed on the last section of auger casing and subsequent pipes thrust into place while the auger tubes are removed from the reception shaft.

If you find any errors with this manual or know of ways to improve procedures, please let us know. Mail your suggestions to: Akkerman Inc, ATTN: Technical Publications, 58256 266th Street, Brownsdale, MN 55918.

Akkerman Inc. reserves the right to improve its product without notice or obligation.

Contents

Safety	1	Controls & Instruments	4
Be Alert For Safety Information	1-1	Thrust Cylinder Control	4-1
Read Operator's Manual	1-1	Drive Rotation Control	4-1
Wear Protective Clothing	1-1	Powered Cutter Head - Auger Control	4-2
Lockout Power Before Servicing	1-2	Make Up Tool Control	4-2
Maintain Battery Safely	1-2	Push Plate Brake Control	4-3
Hydraulic Oil/Fluids Under Pressure	1-2	Hydraulic Latching Control	4-4
Unauthorized Welding	1-3	Hydraulic Pressure Gauges	4-5
Beware of Suspended Loads	1-3	Control Panel Shutdown	4-5
Keep Personnel Away From Moving Parts	1-3	Powered Cutter Head Rotation Control	4-6
Using Plumb Bob	1-3	Jacking Speed Switch	4-6
Handling Auger Casings	1-4	Rotation Pressure Switch	4-7
Regularly Clean/Inspect Equipment	1-4	Theodolite & Camera	4-7
Practice Safe Maintenance	1-4	Tablet PC Monitor	4-8
Avoid Pinch Points	1-5	On & Off Control	4-8
Test Shaft & Tunnel Ventilation	1-5	Gain-Exposure-Zoom-Direction-	
Refueling	1-5	Pipe Count-Status Control	4-8
Fire Prevention	1-6	Screen Brightness Control	4-9
High Pressure Hydraulics	1-6	Using Digitizer Pen	4-9
Use Cylinder Stop	1-6	Accessing The Task Bar/Start Button	4-9
Keep Away From Auger	1-7	Entering Data	4-10
Cooling System	1-7	Power Pack P275T Controls	4-12
Slippery When Wet	1-7	Power Pack P150Q Controls	4-14
Keep Job Site Clean & Organized	1-8	Control Pendant	4-16
No Smoking In Tunnel	1-8		
Avoid Laser Light Exposure	1-8	Pre-Start Inspection	5
Recycle Waste	1-8		
Safety Decals	2	Operation	6
GBM 4812A Frame	2-1	How To Use This Section	6-0-1
Power Pack P275T	2-2	Operation Guidelines & Installation Options ..	6-5-1
Power Pack P150Q	2-3	Operating Guidelines	6-5-1
Thrust Casing Wire Baskets.....	2-4	GBM Installation Options	6-5-2
Pilot Tube Rack - 30 In	2-5	Three Step Method.....	6-5-2
Pilot Tube Rack - 5 ft	2-5	for 11" to 16" OD Pipe	6-5-2
		With PCH20-28.5 for 20"-35.5" OD Pipe ..	6-5-3
		With PCH36 & 44 for 36"-48" OD Pipe	6-5-4
Terminology	3	Shaft Set Up	6-10-1
GBM 4812A Frame		Setting Up Launch & Reception Shafts .	6-10-1
SN 1 - 3	3-1	GBM Frame Set Up In Shaft	6-15-1
SN 4 & After	3-2	Setting Up GBM In Launch Shaft	6-15-1
GBM 4812A Controls		GBM Frame Quick Coupler Installation	6-15-6
SN 1 - 3	3-3	Power Pack Operation	6-20-1
SN 4 & After	3-4	Starting The Engine - P275T	6-20-1
GBM Hydraulic Console (SN 4 & After)	3-5	Starting The Engine - P150Q	6-20-3
Power Pack P275T	3-6	Stopping The Engine - Emergency Stop ..	6-20-6
Power Pack P150Q	3-7	Adjusting Thrust Pressure	6-20-7
Guidance System	3-8	Guidance System Set Up	6-25-1
Tablet PC Assembly	3-9	Theodolite Zero Point Calibration	6-25-1
Without Remote Focus (SN FA42035F-86 & Before) ..	3-9	Assembling Guidance System	6-25-6
Remote Focus Kit (SN FA42035F-86 & Before) .	3-10	Preliminary Theodolite Setup	
With Remote Focus (SN FA42035F 87 & After) .	3-11	Line/Grade.....	6-25-11
Tablet PC Controls	3-12	Tablet PC Start Up & Operation	6-25-20
Camera Optics	3-13	On & Off Control	6-25-21
Theodolite	3-14	Gain-Exposure-Zoom-Direction-	
Powered Cutter Head		Pipe Count-Status Control	6-25-21
20 - 22.5 - 28.5	3-16	Using Digitizer Pen	6-25-22
36 & 44	3-17	Accessing The Task Bar/Start Button.	6-25-22
Tooling	3-18	Entering Data	6-25-22
Three Step Method		Using Theodolite Remote Focus	6-25-23
for 11" - 16" OD Pipe	3-18	Cleaning Tablet PC Screen	6-25-24
With PCH 20-28.5 for 20"-35.5" OD Pipe...	3-20		
With PCH 36&44 for 36"-48" OD Pipe	3-22		

(continued on next page)

Operation (continued)	
Guidance System Set Up	
Tablet PC Start Up & Operation (continued)	
Docking Station - Removal/Replace	6-25-25
Connecting New Camera To Computer	6-25-26
Checking Guidance System Camera Connections	6-25-27
Final Theodolite Set Up	6-25-28
Installing Pilot Tubes	6-30-1
Installing Steering Head Adapter To Steering Head	6-30-1
Installing Pilot Tubes	6-30-6
Log Of Progress	6-30-14
Installing Upsizing Tool	6-35-1
Three Step Method: Installing Auger Casing With Reaming Head	6-35-1
Upsizing Tool Lubrication From Reception Shaft	6-35-20
Installing Safety Chain Assembly/Casing Auger Pin To Auger & Casing	6-35-22
Installing Integral Bearing Swivel	6-35-24
Using The Latching System	6-35-47
Using The Powered Cutter Head	6-35-51
Use Jetting & Pipe Lubrication With Powered Cutter Head	6-35-51
Soil Stabilization	6-35-54
Installing Powered Cutter Head	
PCH 20, 22.5, & 28.5	
Front Section	6-35-55
Rear Section	6-35-68
PCH 36 & 44	
Front Section	6-35-78
Rear Section	6-35-88
Removing Powered Cutter Head From Reception Shaft	6-35-101
Installing Product Pipe	6-40-1
Three Step Method: Installing Product Pipe	6-40-1
Miscellaneous	6-45-1
Pilot Tube Pull Back Thru Launch Shaft	6-45-1
Transporting	7
Transporting Guidelines	7-1
Fuels & Lubricants	8
Fuel Specifications	8-1
Engine Oil - P275T	8-1
Engine Oil - P150Q	8-2
Power Pack Oil Reservoir Lubricant	8-2
Auger Drive Lubricant	8-3
Grease	8-3
Breakout Tool Power Unit Lubricant	8-3
Engine Coolant	8-4
PCH Bearing Cavity & Gear Box Lubricant	8-4
Bearing Swivel Bearing Cavity Lubricant	8-5
Storing Lubricants	8-5
Periodic Maintenance	9
Lubrication & Maintenance Intervals	9-1
Lockout Power Before Servicing	9-1
Avoid Pinch Points	9-1
Install Cylinder Stops Prior To Maintenance	9-2
Hydraulic Oil/Fluids Under Pressure	9-2
Maintenance Charts - 4812A-P275T-P150Q	9-3
Prior To Each Job Launch	9-3
Daily or Every 10 Hours	9-4
First 100 Hours & Every 500 Hours	9-5
Monthly or Every 250 Hours	9-6
Every 500 Hours of Operation	9-7
Every 1000 Hours of Operation	9-8
Every 2000 Hours of Operation	9-9
After Each Drive	9-10
After Every 2000 Feet	9-11
As Required	9-12
Periodic Maintenance (continued)	
Maintenance Procedures	9-13
Prior To Each Job Launch	9-13
Daily or Every 10 Hours	9-18
First 100 Hours & Every 500 Hours	9-30
Monthly or Every 250 Hours	9-33
Every 500 Hours of Operation	9-38
Every 1000 Hours of Operation	9-49
Every 2000 Hours of Operation	9-54
After Each Drive	9-59
After Every 2000 Feet	9-60
As Required	9-61
Maintenance Charts - Powered Cutter Head	9-64
Prior To Each Job Launch	9-64
After Each Drive	9-65
After Every 2000 Feet	9-66
Maintenance Procedures	9-67
Prior To Each Job Launch	9-67
After Each Drive	9-72
After Every 2000 Feet	9-76
Storage	10
Preparing For Storage	10-1
Removing From Storage	10-2
Troubleshooting	11
Guided Boring Machine	11-1
Power Pack Engine	11-2
Powered Cutter Head (PCH)	11-7
Tablet PC	11-8
Hydraulic Schematic	
GBM 4812A	11-16
Power Pack P150Q	11-19
Power Pack P275T	11-18
PCH 20	11-23
PCH 22.5	11-24
PCH 28.5	11-25
Electrical Schematic	
GBM 4812A	11-20
Power Pack P150Q	11-22
Power Pack P275T	11-21

(continued on next page)

Specifications	12	Identification Numbers	13
GBM 4812A Frame	12-1	Material Safety Data Sheets	14
Power Pack P275T	12-2	Warranty	15
Power Pack P150Q	12-3	Index	16
Guidance System	12-4		
Breakout Tool Power Unit	12-5		
Powered Cutter Head	12-6		
Integral Bearing Swivel Cutter Head	12-7		
Torque Chart	12-8		
Understanding Grade Degrees Versus Grade Percent.....	12-9		

Safety

BE ALERT FOR SAFETY INFORMATION

When you see this safety alert symbol on your equipment or in this manual, be alert to the possibility of personal injury or property damage.

Read all safety information.

Keep safety decals clean and in good condition.
Replace missing or damaged safety decals.



**ATTENTION!
BECOME ALERT!
YOUR SAFETY IS INVOLVED!**

READ OPERATOR'S MANUAL

⚠ WARNING Unsafe operation or maintenance can cause severe injury or death.

Read and understand the Operator's Manual before operating or servicing this equipment.

Any unauthorized modifications will void the warranty.

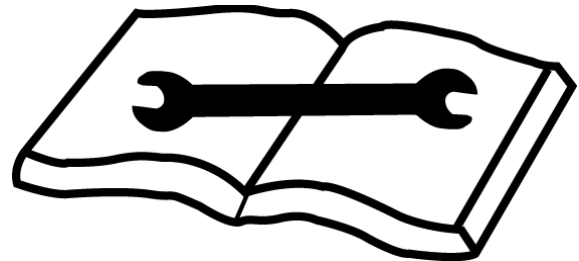

WEAR PROTECTIVE CLOTHING

Wear OSHA approved protective clothing, such as hard hat, gloves, safety goggles, earmuffs or ear plugs, face shield, and steel-toed boots, when operating and servicing this equipment.

Wear reasonably close fitting clothing and remove jewelry before working on or near this equipment. This will help prevent the danger of catching them in moving parts or controls.



LOCKOUT POWER BEFORE SERVICING

⚠ WARNING Failure to lockout power before servicing can cause severe personal injury or death.

LOCKOUT main power supply before servicing. Electrical repairs must be performed only by a certified electrician.



MAINTAIN BATTERY SAFELY

⚠ WARNING Batteries produce explosive gases.

Wear eye protection and protective clothing during battery service.

Keep sparks, flames, and cigarettes away from batteries.

Contact with battery acid can cause severe burns. Flush immediately and thoroughly with clean water. Get medical attention immediately.

Charge a battery only in a well-ventilated area.

Never charge a frozen battery.

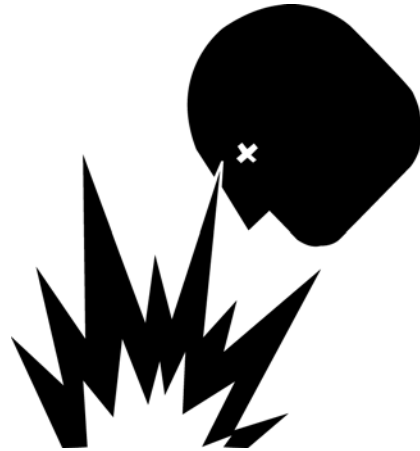

HYDRAULIC OIL/FLUIDS UNDER PRESSURE

⚠ WARNING Escaping oil or other fluids under pressure can penetrate your skin causing serious injury.

Release all pressure before performing maintenance or repairs. Never weld near pressurized fluid lines.

DO NOT use your hands to check for leaks. When searching for leaks, use a piece of wood or cardboard.

Contact medical help immediately if any oil or fluid is injected into your skin. A serious infection or reaction can emerge without proper medical treatment.



UNAUTHORIZED WELDING

⚠ WARNING Unauthorized welding can cause structural failure resulting in possible injury or death.

Do not weld on any structural member.
Unauthorized welding or repair will void the warranty.

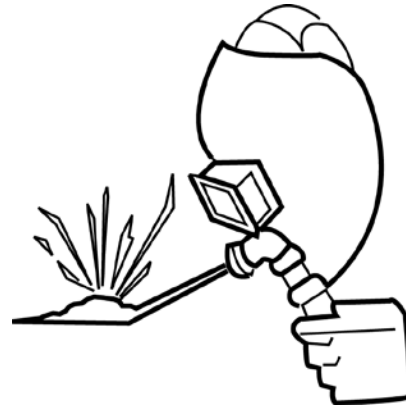

BEWARE OF SUSPENDED LOADS

⚠ WARNING Suspended loads may fall and cause severe personal injury or death.

If a hydraulic hose breaks from the boom of a crane/excavator, or the lifting support fails, the boom and/or load can fall instantly.

Do not enter area under or around a suspended load.



KEEP PERSONNEL AWAY FROM MOVING PARTS

⚠ WARNING Crushing hazard.
Keep personnel away from inside of GBM when jacking or moving GBM. Failure to do so could result in serious personal injury or death.

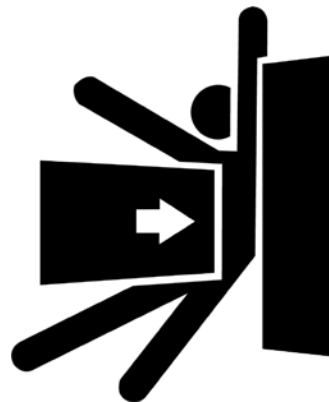

USING PLUMB BOB

⚠ WARNING Falling plumb bob can cause serious personal injury or death, and/or equipment damage.

NEVER hang or secure the plumb bob overhead when not in use.

ALWAYS remove the plumb bob from the string lines and place in storage container after use.

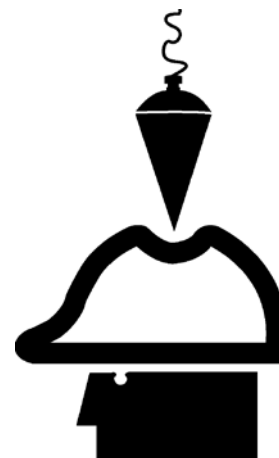

HANDLING AUGER CASINGS

⚠ WARNING Auger may fall out of casing and cause severe injury or death if casing tips or hits an obstruction.

Properly install safety chain assembly or casing auger pin to augers and casings before lowering into or lifting out of shaft.

Do not stand or walk under a load.



REGULARLY CLEAN AND INSPECT EQUIPMENT

Remove any grease, oil, or debris buildup to avoid potential injury or equipment damage.

Inspect equipment for damage. If damaged, repair or replace immediately.

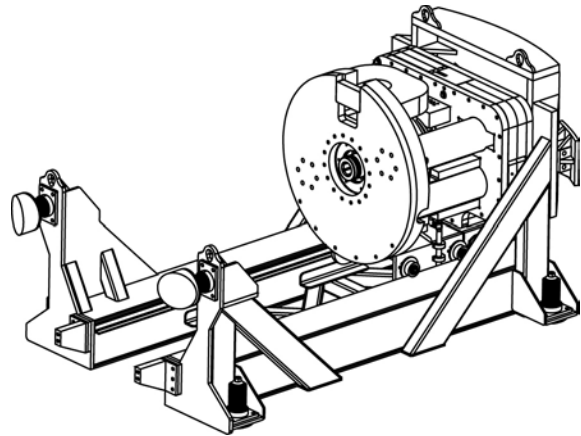

PRACTICE SAFE MAINTENANCE

⚠ WARNING Unexpected Jacking System movement may cause serious personal injury.

LOCKOUT power before performing any maintenance.

Shut down GBM before making repairs, adjustments, or removing obstructions.

Only trained and qualified personnel should perform maintenance or repairs.

Keep the area around the equipment clean and dry when performing maintenance.

Do not service the machine while it is in motion.

Replace worn or damaged parts. Remove grease, oil, or debris buildup.



AVOID PINCH POINTS

⚠ WARNING Moving parts or the mishandling of parts can cause severe personal injury.

Keep hands away from moving parts.

Watch your fingers, hands, and legs while equipment is in operation.

Handle parts carefully to avoid crushing and pinch point hazards.

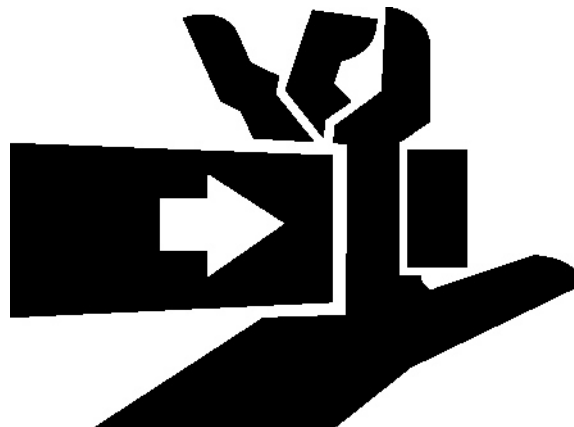

TEST SHAFT & TUNNEL VENTILATION

⚠ WARNING Keep shafts and tunnel well ventilated at all times.

Use an approved air analyzer to detect hazardous gases and oxygen content.

Before and during the shaft operation, test for combustible and toxic gases and oxygen deficiency.

If the levels exceed OSHA prescribed levels, leave tunnel and shaft immediately! Do not activate or deactivate any electrical or hydraulic devices, since any sparks could cause an explosion.

Once ALL personnel are out of tunnel/shaft, cut power from power source.

Gases must be removed before reentering tunnel/shaft.

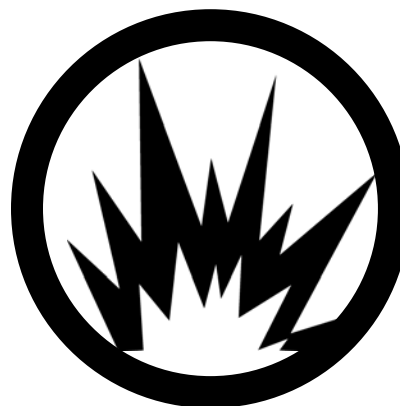
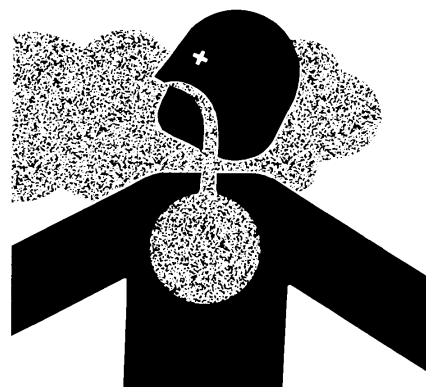

REFUELING

⚠ WARNING Fires and explosions can cause serious injury or death.

Handle fuel with care. It is highly flammable.

DO NOT refuel power pack while smoking or when near open flame or sparks.

Always stop engine before refueling power pack.



FIRE PREVENTION

⚠ CAUTION Fires can cause injury or property damage.

Keep equipment clean. Remove all debris from equipment.

Have a fire extinguisher available at all times. Keep the fire extinguisher fully charged.



HIGH PRESSURE HYDRAULICS

⚠ WARNING The GBM contains high pressure hydraulics.

Keep all guards in place.

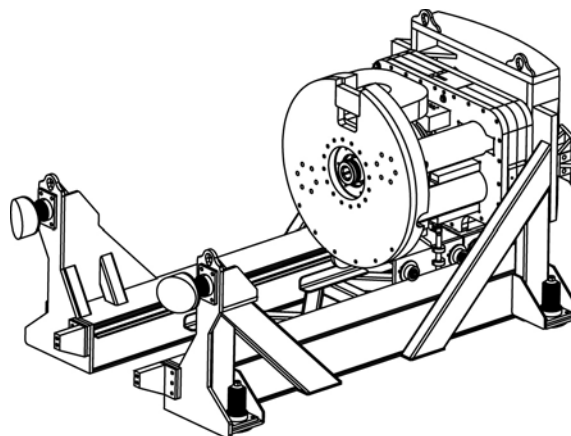

USE CYLINDER STOP

⚠ WARNING Crushing hazard.

BEFORE setting up theodolite or performing maintenance in the rear area of the 4812A frame, the P275T Power Pack must be shut down and the cylinder stop (A) must be placed on cylinder rod.

Failure to do may result in serious personal injury or death.

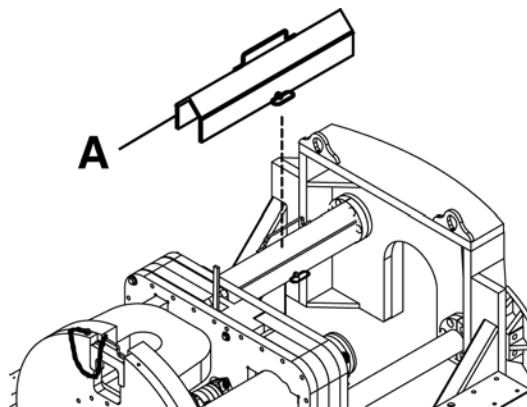

KEEP AWAY FROM AUGER

⚠ DANGER Contact with rotating auger will cause severe injury or death.

Keep hands, body, and objects clear of operating auger.

Do not operate without covers and guards in place.

Lockout power before servicing.

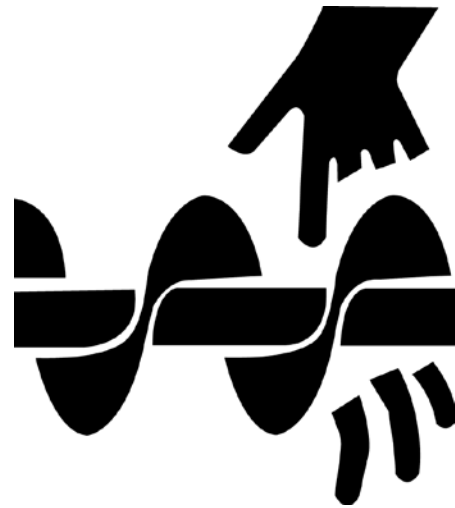

COOLING SYSTEM

⚠ WARNING Cooling system under pressure. Explosive release of HOT engine coolant can cause severe burns. SLOWLY remove the radiator cap ONLY if the engine is cool.



SLIPPERY WHEN WET

⚠ WARNING Slips and falls can cause serious personal injury.

Ensure firm footing in wet or slippery conditions.

Replace skid-resistant material if it is damaged or missing to prevent slips and falls.

Remove any buildup of grease, oil, or debris.



KEEP JOB SITE CLEAN AND ORGANIZED

⚠ WARNING Tripping can cause serious personal injury.

Be sure to keep job site clean and organized.



NO SMOKING IN TUNNEL

⚠ WARNING Smoking in tunnel could cause an explosion if combustible gases are present.

Do not smoke in tunnel.



AVOID LASER LIGHT EXPOSURE

⚠ DANGER Staring into laser light will cause severe injury.

Do not stare into laser guidance system light beam. Avoid direct eye exposure.

To avoid possible exposure to radiation in excess of acceptable emission limits, all repairs to laser must be performed by the original manufacturer or an authorized service technician.

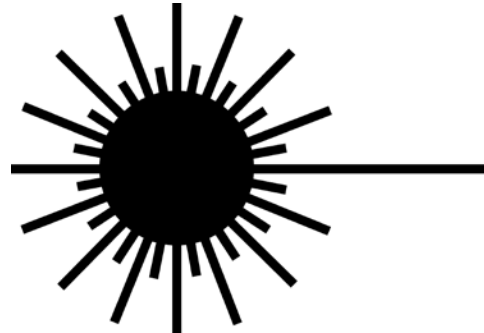

RECYCLE WASTE

Follow local, state, federal, and international regulations when recycling or disposing of waste. Waste includes fluids/oil, fuel, filters, coolant, and batteries.

Use leakproof containers when draining fluids/oil. Do not pour waste on the ground, down a drain, or into any water source.

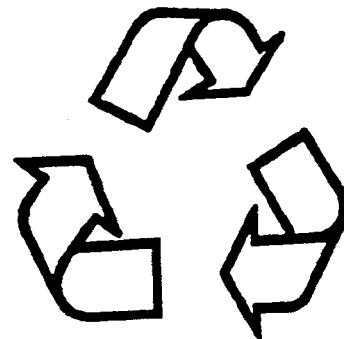

Safety Decals

Keep all safety decals clean and readable. Use soft cloth, water, and a mild soap to clean the decals if they are too dirty to read. DO NOT clean safety decals with solvent. Solvent can damage them. Replace safety decals immediately if they are damaged, missing, or hard to read.

Serious injury or property damage can occur if safety instructions are not followed. Contact your Akkerman Product Support representative for free replacement safety decals.

If a part is replaced that has a safety decal on it, apply a new safety decal to the replacement part. Before applying a new decal, be sure the surface is clean and dry.

GBM - 4812A FRAME

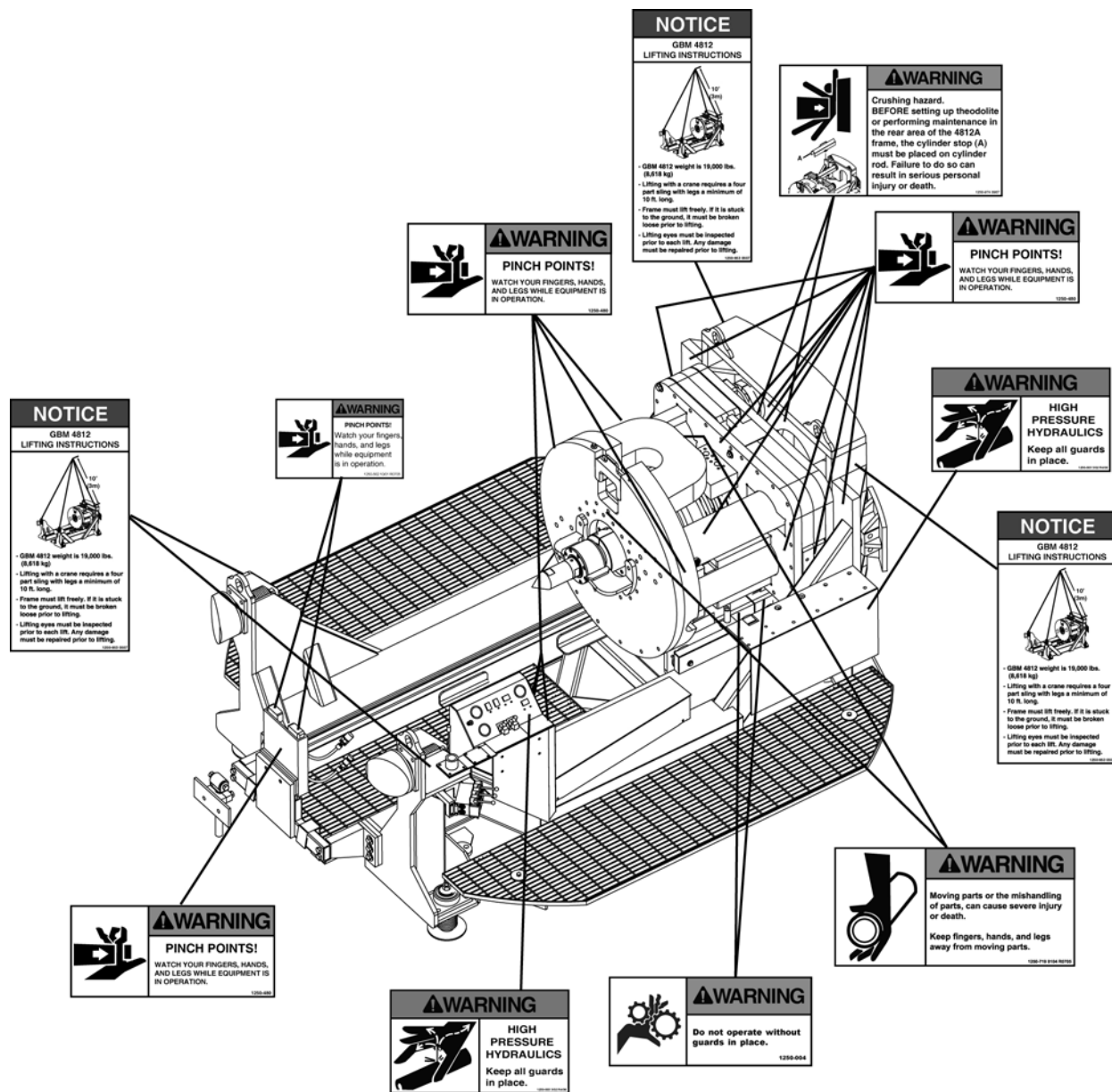

POWER PACK P275T

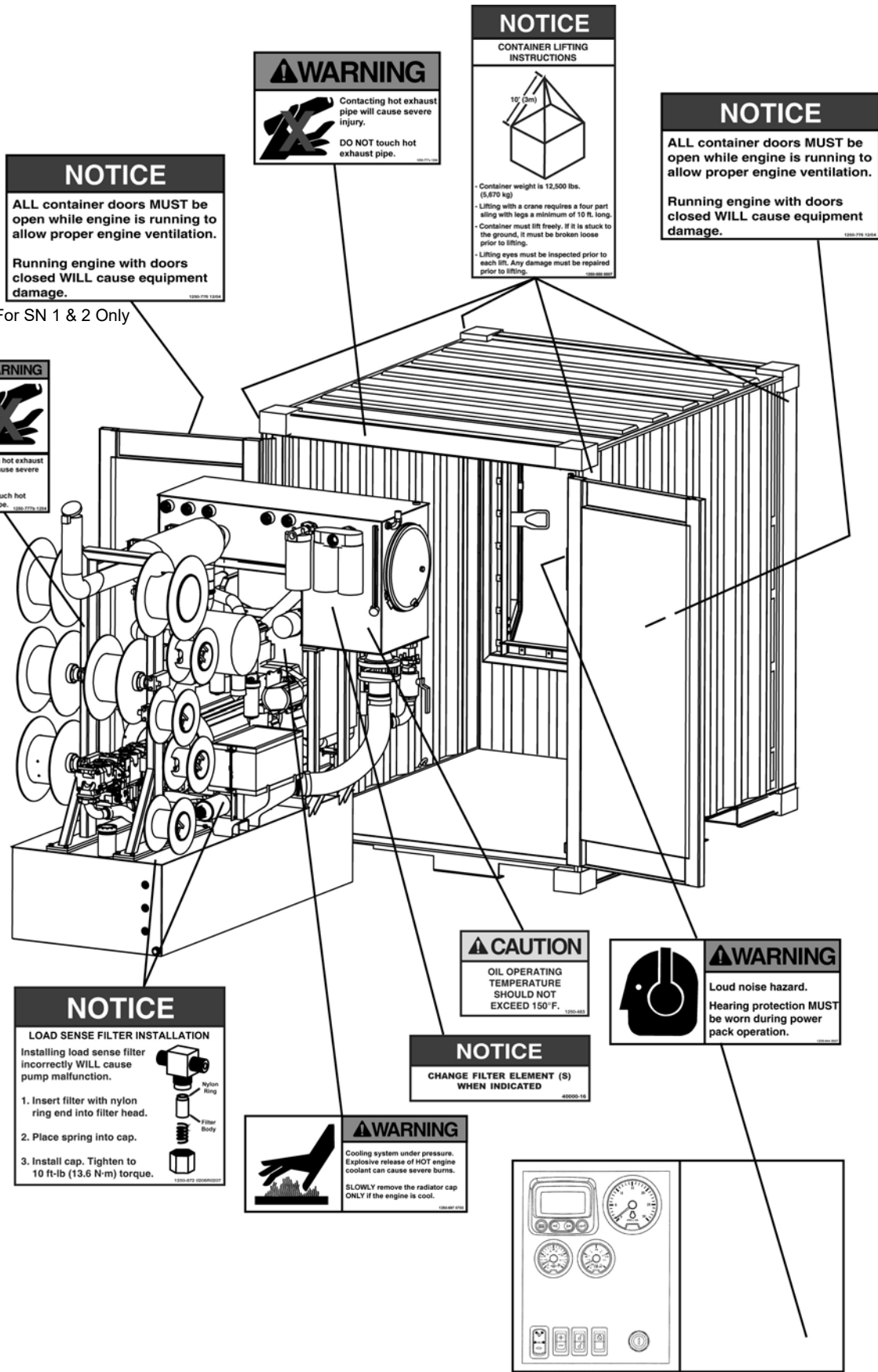

NOTICE

ALL container doors **MUST** be open while engine is running to allow proper engine ventilation.

Running engine with doors closed **WILL** cause equipment damage.

1200-178-1204

For SN 1 & 2 Only

WARNING

Contacting hot exhaust pipe will cause severe injury.

DO NOT touch hot exhaust pipe.

1200-178-1204

NOTICE

CONTAINER LIFTING INSTRUCTIONS

10' (3m)

- Container weight is 12,500 lbs. (5,670 kg)
- Lifting with a crane requires a four part sling with legs a minimum of 10 ft. long.
- Container must lift freely. If it sticks to the ground, it must be broken loose prior to lifting.
- Lifting eyes must be inspected prior to each lift. Any damage must be repaired prior to lifting.

1200-178-1204

NOTICE

ALL container doors **MUST** be open while engine is running to allow proper engine ventilation.

Running engine with doors closed **WILL** cause equipment damage.

1200-178-1204

WARNING

Contacting hot exhaust pipe will cause severe injury.

DO NOT touch hot exhaust pipe.

1200-178-1204

CAUTION

OIL OPERATING TEMPERATURE SHOULD NOT EXCEED 150°F.

1200-413

WARNING

Loud noise hazard.

Hearing protection **MUST** be worn during power pack operation.

1200-178-1204

NOTICE

LOAD SENSE FILTER INSTALLATION

Installing load sense filter incorrectly **WILL** cause pump malfunction.

1. Insert filter with nylon ring end into filter head.
2. Place spring into cap.
3. Install cap. Tighten to 10 ft-lb (13.6 N-m) torque.

1200-412 0200000000

NOTICE

CHANGE FILTER ELEMENT (S) WHEN INDICATED

40000-10

WARNING

Cooling system under pressure. Explosive release of **HOT** engine coolant can cause severe burns.

SLOWLY remove the radiator cap **ONLY** if the engine is cool.

1200-412 0100000000

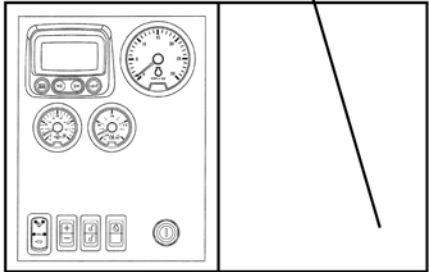

GBM - POWER PACK P150Q

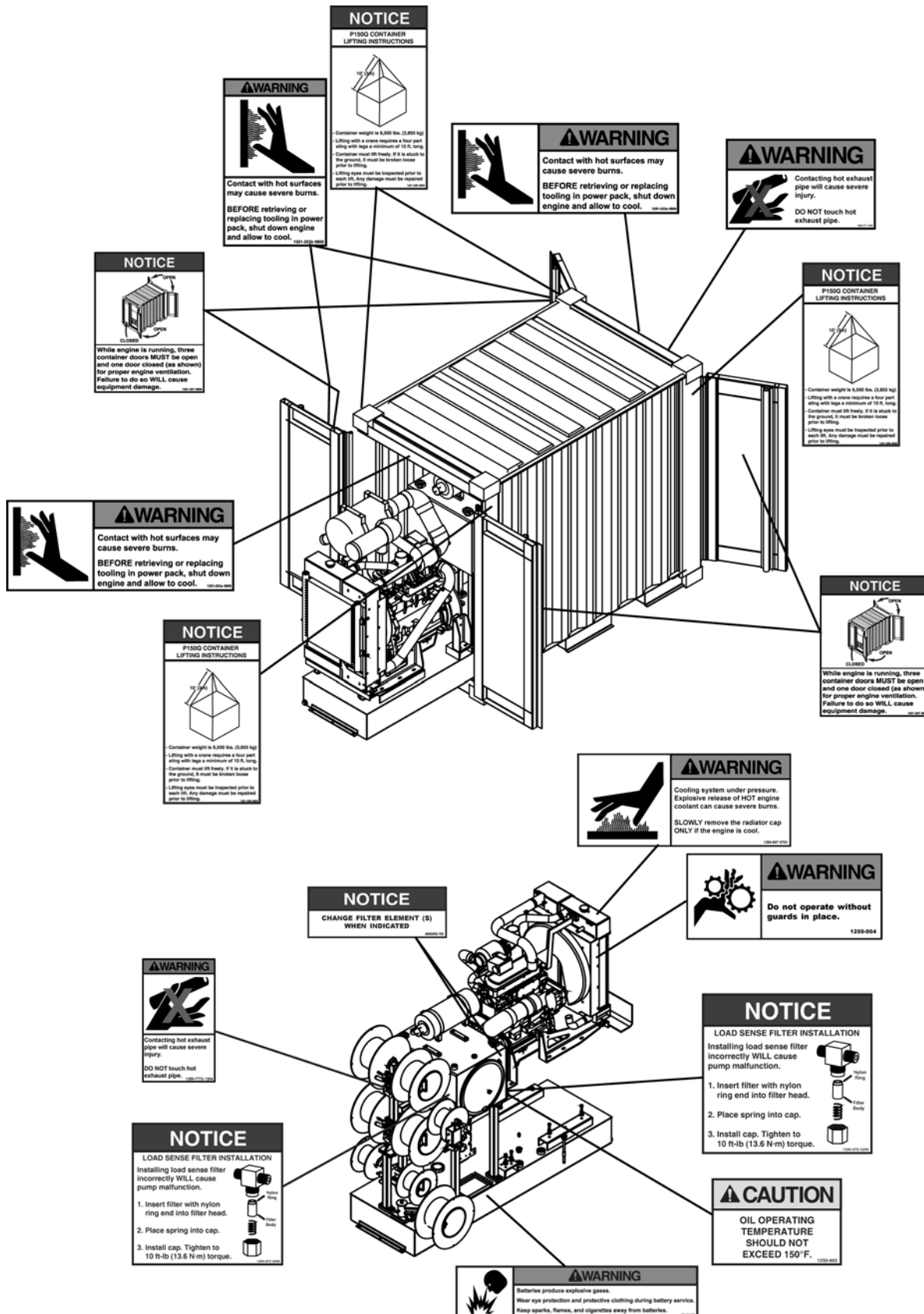

THRUST CASING WIRE BASKETS



WARNING

Load binder could spring open and cause serious injury or death.





After load binder is locked into place, slide load binder retainer over handle to prevent load binder from accidentally opening.

When opening load binder, keep yourself out of the path of the moving handle.

NOTICE

BASKET SPECIFICATIONS & INSTRUCTIONS

- Maximum Gross Weight Capacity: 6,000 lbs. (2,722 kg)
- Basket Part Number: FA4353F
- Lifting basket requires a four part sling with legs a minimum of 6 ft. (2.44 m) long.
- Basket lifting eyes **MUST** be inspected prior to each lift. **ANY** damage **MUST** be repaired prior to lifting basket.
- Basket door **MUST** be locked properly in place with load binder and load binder retainer before lifting.
- Load baskets on trailer so basket doors are facing the inside of trailer bed.
- Baskets can **ONLY** be stacked two high.
- Door can be removed by completely lowering door, then lifting door up off of hinge tube.
- Auger casings **MUST** be placed into basket so the casings do not roll out when door is lowered.
- Auger casings cannot extend above top tubing of basket.



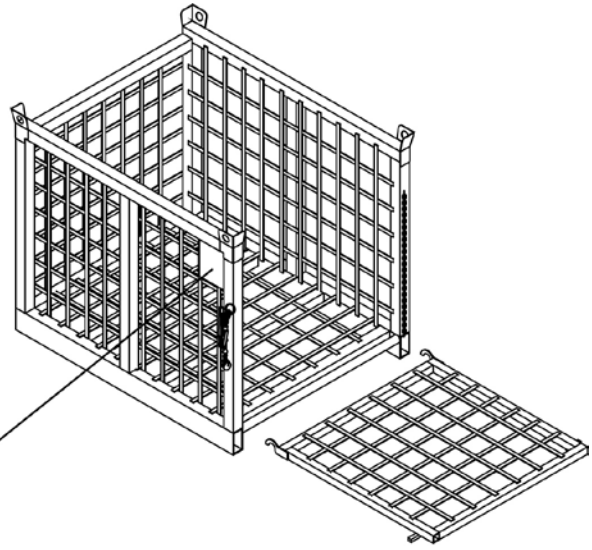
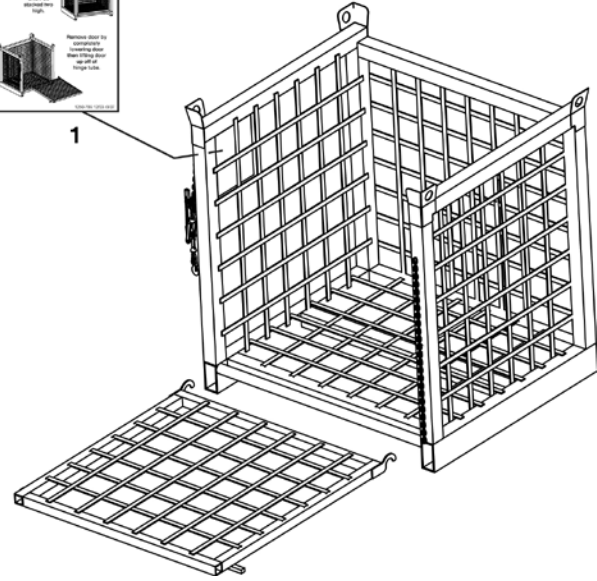

WARNING

Load binder could spring open and cause serious injury or death.



After load binder is locked into place, slide load binder retainer (A) over handle to prevent load binder from accidentally opening.

When opening load binder, keep yourself out of the path of the moving handle.

NOTICE

BASKET SPECIFICATIONS & INSTRUCTIONS

- Maximum Gross Weight Capacity: 8,300 lbs. (3,765 kg)
- Basket Part Number: FA43576F
- Lifting basket requires a four part sling with legs a minimum of 8 ft. (2.44 m) long.
- Basket lifting eyes **MUST** be inspected prior to each lift. **ANY** damage **MUST** be repaired prior to lifting basket.
- Basket door **MUST** be locked properly in place with load binder and load binder retainer before lifting.
- Load baskets on trailer so basket doors are facing the inside of trailer bed.
- Baskets can **ONLY** be stacked two high.
- Door can be removed by completely lowering door, then lifting door up off of hinge tube.
- Auger casings **MUST** be placed into basket so the casings do not roll out when door is lowered.
- Auger casings cannot extend above top tubing of basket.

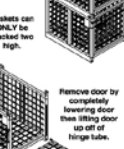
PILOT TUBE RACK - 30 IN

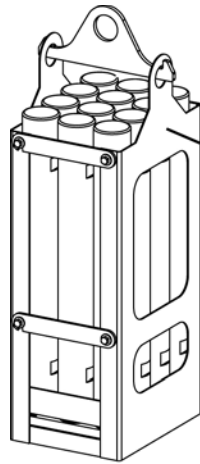

NOTICE

**PILOT TUBE RACK
LIFTING INSTRUCTIONS**

Lifting Bar
10'
(3m)

10' (3m)
Lift Holder

- Single rack weight with twelve pilot tubes is 1,050 lbs. (476 kg).
- Lifting with a crane requires a sling to the lifting bar (single rack) or two part sling for lift holder (2 or 3 racks) with legs a minimum of 10 ft. long.
- Rack(s) must lift freely. If it is stuck to the ground, it must be broken loose prior to lifting.
- The lift collars on lift holder must be secured to the outside end of the racks prior to lifting racks.
- The pilot tubes must be secured in rack prior to lifting.

1250-965 0707

PILOT TUBE RACK - 5 FT

NOTICE

**PILOT TUBE RACK
LIFTING INSTRUCTIONS**

10'
(3m)

- Rack weight with pilot tubes is 4,000 lbs. (1,814 kg)
- Lifting with a crane requires a four part sling with legs a minimum of 10 ft. long.
- Rack must lift freely. If it is stuck to the ground, it must be broken loose prior to lifting.
- Lifting loops must be inspected prior to each lift. Any damage must be repaired prior to lifting.

1250-954 0507

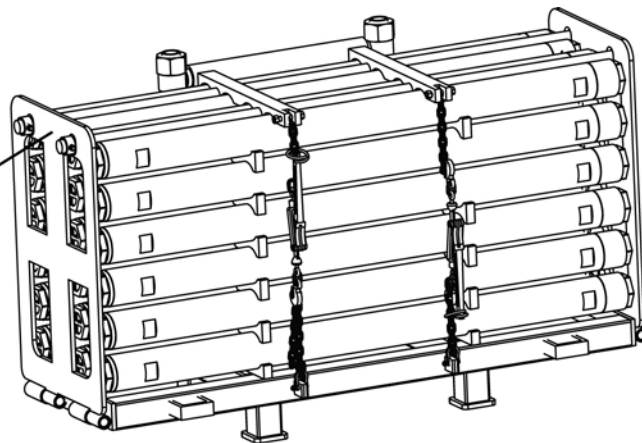

NOTES

Terminology

GBM 4812A JACKING FRAME (SN 1 - 3)

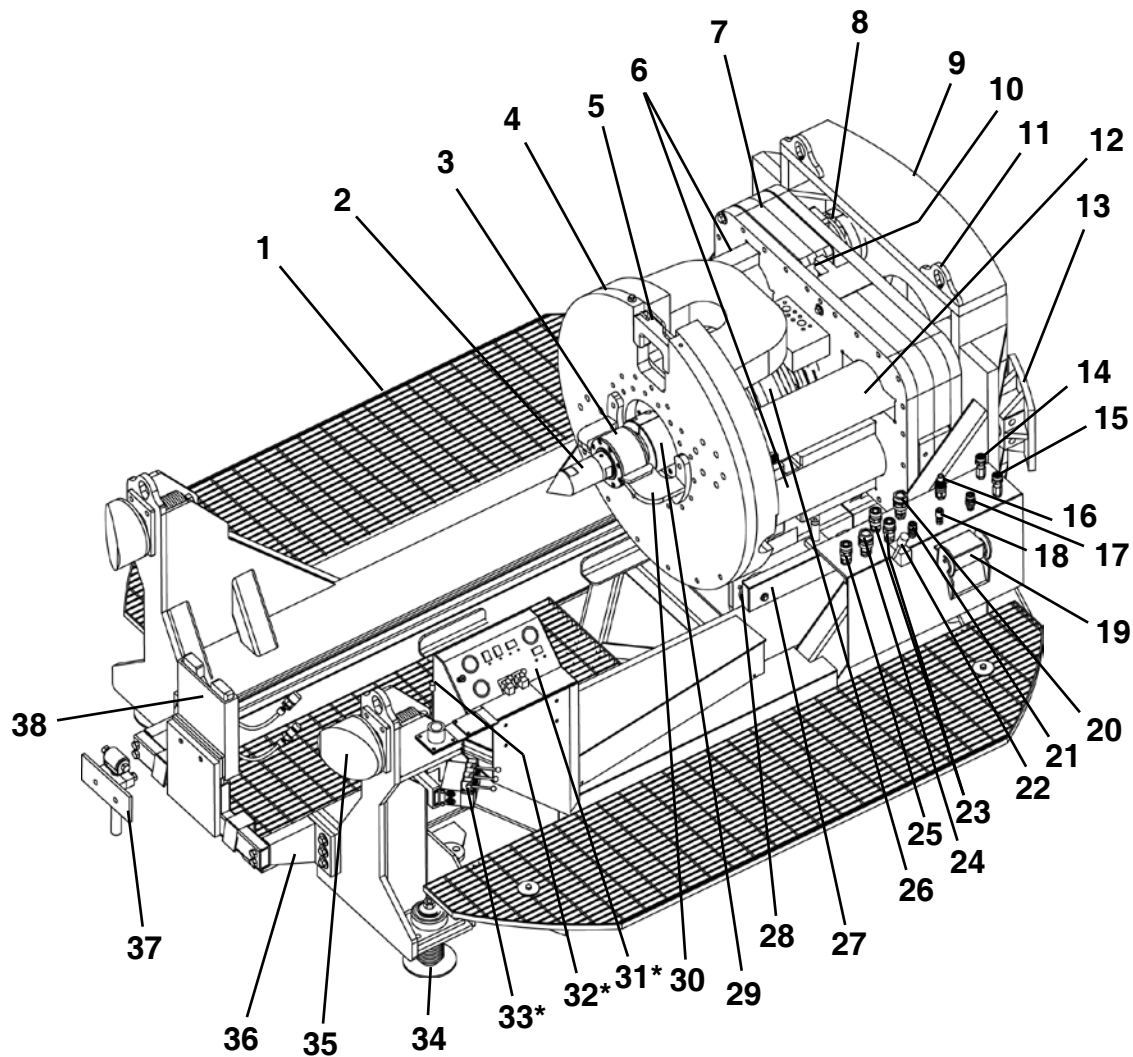

- | | | |
|------------------------------|---|------------------------------|
| 1. Operator Platform | 14. Jacking Pressure QD | 26. Auger Drive Motor |
| 2. Alignment Guide Rod | 15. Jacking Load Sense QD | 27. Wheel Guard |
| 3. Fluid Swivel | 16. Drive Rotation/PCH Auger Drive Pressure IN QD | 28. Wheel |
| 4. Push Plate (Thrust Block) | 17. Case Drain QD | 29. Pullback Coupler |
| 5. Ring Segment | 18. Rotational Load Sense QD | 30. Swivel Support |
| 6. Thrust Cylinder - Keyed | 19. PCH Auger Drive QD | 31. Control Console* |
| 7. Rabbit Assembly | 20. Tank QD | 32. Thrust Cylinder Control* |
| 8. Cylinder Retainer | 21. Cutter Head Load Sense QD | 33. Control Valve Bank* |
| 9. Frame Assembly | 22. Power Cutter Head Rotation Control | 34. Leveling Assembly |
| 10. Latching Indicator | 23. Cutter Head Control QD | 35. Front Anchor Block |
| 11. Lifting Eye | 24. Tank QD | 36. Rail Extension |
| 12. Thrust Cylinder - Fixed | 25. Cutter Head Pressure IN QD | 37. Casing Support |
| 13. Rear Push Pad | | 38. Make Up Tool |

* For control identification, refer to GBM 4812A Controls (SN1 - 3) in this section.

QD - Quick Disconnect

GBM 4812A JACKING FRAME (SN 4 & AFTER)

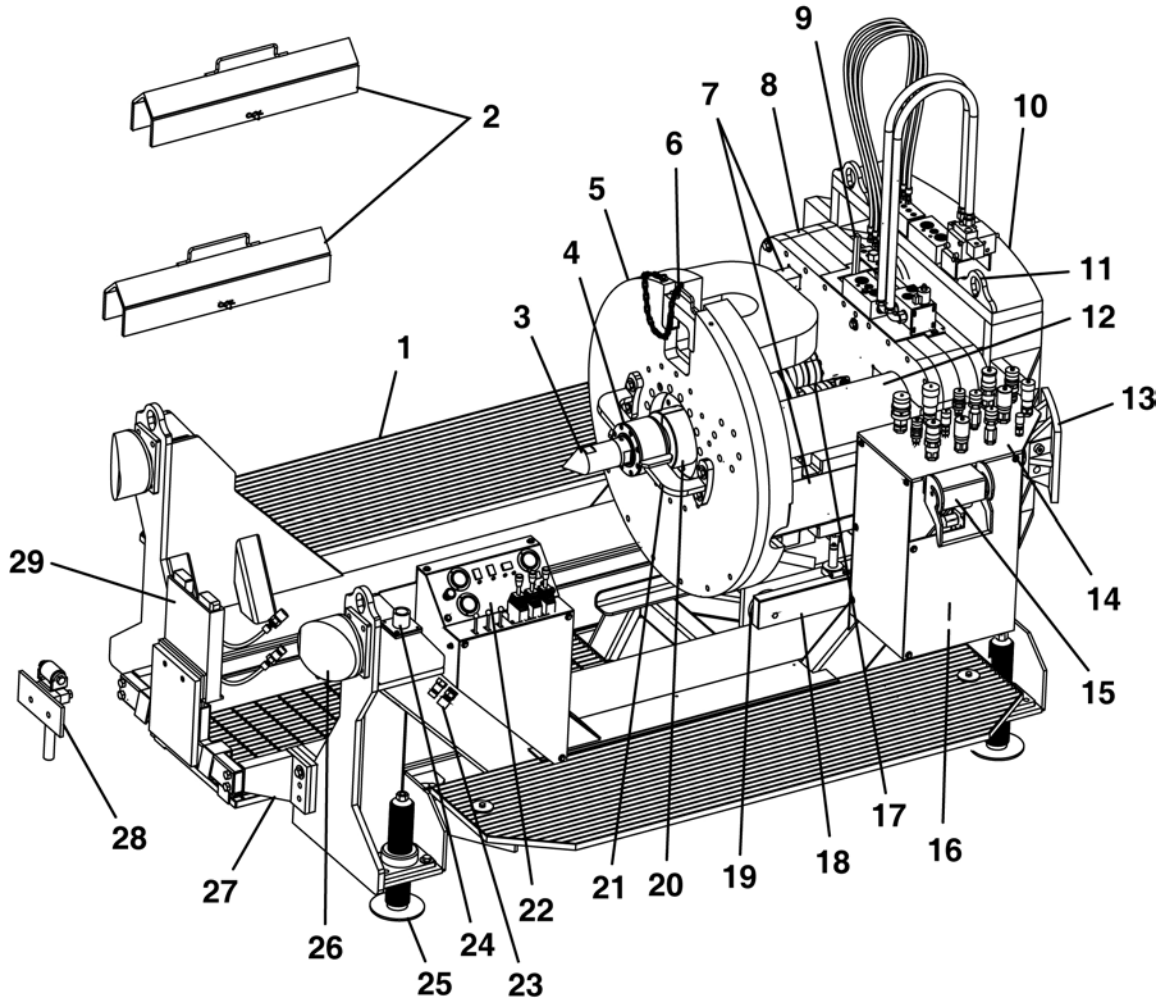

- | | | |
|-------------------------------|--|----------------------------------|
| 1. Operator Platform | 11. Lifting Eye | 21. Swivel Support |
| 2. Cylinder Stops | 12. Thrust Cylinder - Fixed | 22. Control Console** |
| 3. Alignment Guide Rod | 13. Rear Push Pad | 23. Make Up Tool Hyd. Connection |
| 4. Fluid Drive Swivel Adapter | 14. Hydraulic Console* | 24. Tablet PC Mount |
| 5. Push Plate (Thrust Block) | 15. PCH Auger Drive QD | 25. Leveling Assembly |
| 6. Handled Ring Segment | 16. Power Cutter Head Rotation Control | 26. Front Anchor Block |
| 7. Thrust Cylinder - Keyed | 17. Auger Drive Motors | 27. Rail Extension |
| 8. Rabbit Assembly | 18. Wheel Guard | 28. Casing Support |
| 9. Latching Indicator | 19. Wheel | 29. Make Up Tool |
| 10. Frame Assembly | 20. Pullback Coupler | |

* For hydraulic console identification, refer to GBM 4812A Hydraulic Console (SN 4 & After) in this section.

** For control console identification, refer to GBM 4812A Controls (SN 4 & after) in this section.

QD - Quick Disconnect

GBM 4812A CONTROLS (SN 1-3)

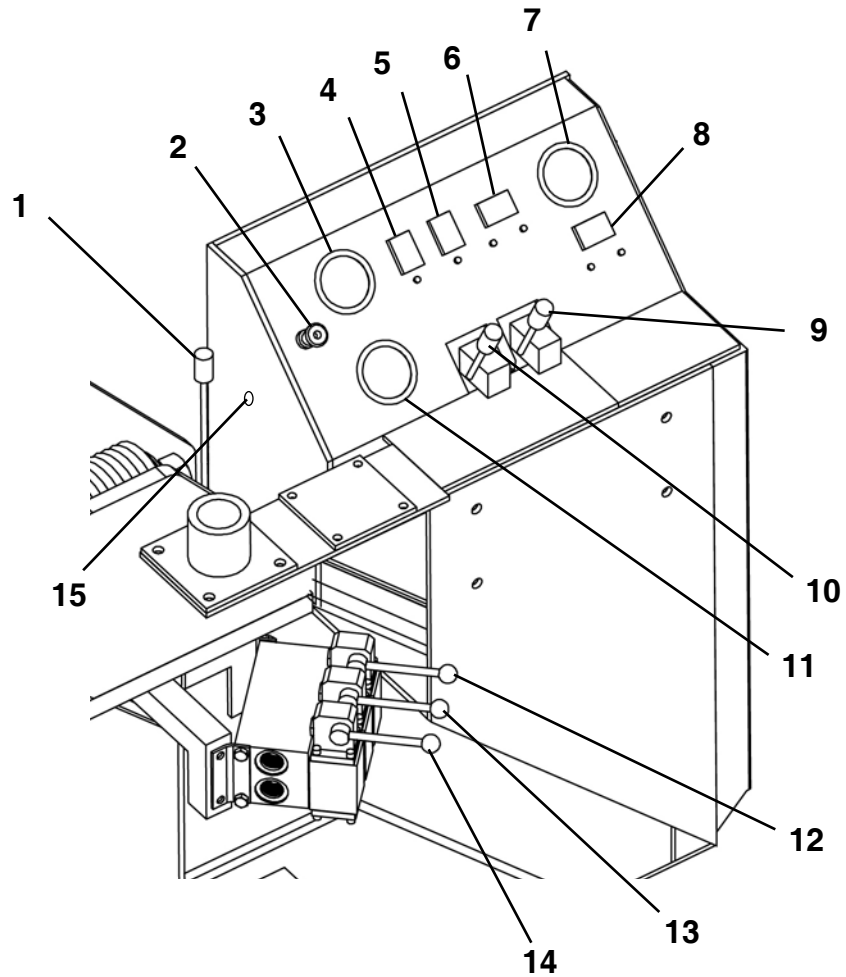

- | | |
|------------------------------------|---------------------------------------|
| 1. Thrust Cylinder Control | 9. PCH Auger Control |
| 2. Control Panel Shutdown | 10. Drive Rotation Control |
| 3. Jacking Pressure Gauge | 11. Drive Rotation/PCH Auger Drive |
| 4. Jacking Speed Switch | 12. Hydraulic Latching Control |
| 5. Rotation Pressure Switch | 13. Push Plate Brake Control |
| 6. PCH Auger Drive Switch | 14. Make Up Tool Control |
| 7. PCH Cutter Drive Pressure Gauge | 15. Control Panel Power Supply 12 VDC |
| 8. PCH Cutter Drive Switch | |

GBM 4812A CONTROLS (SN 4 & AFTER)

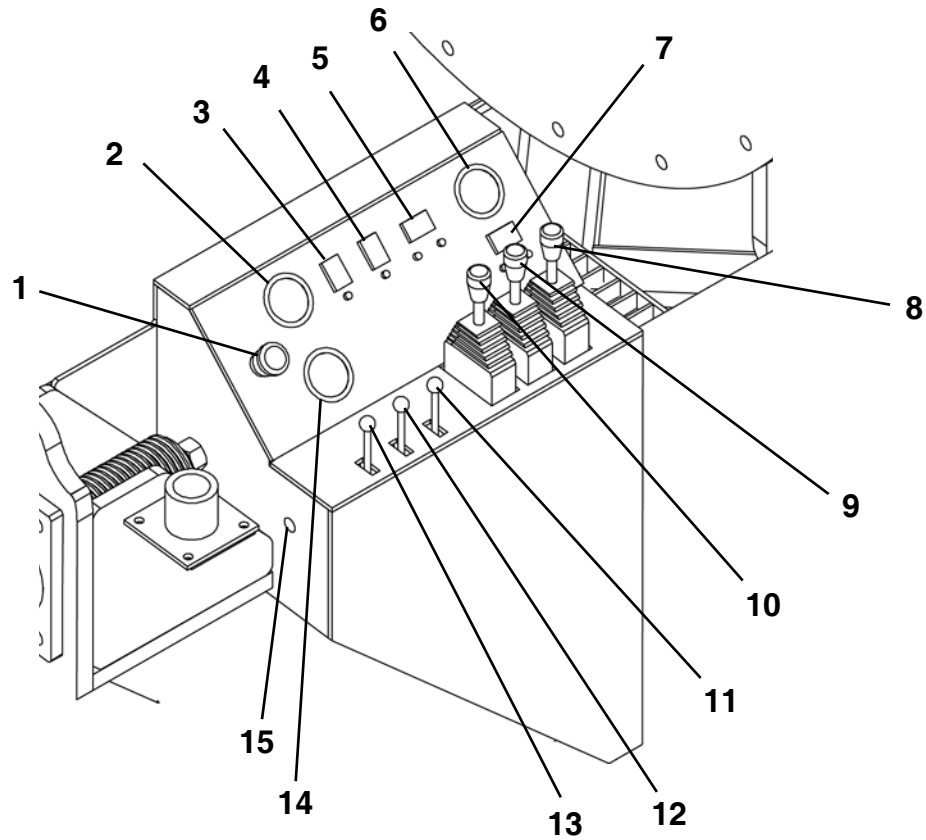

- | | |
|------------------------------------|--|
| 1. Control Panel Shutdown | 9. Drive Rotation Control |
| 2. Jacking Pressure Gauge | 10. Thrust Cylinder Control |
| 3. Jacking Speed Switch | 11. Hydraulic Latching Control |
| 4. Rotation Pressure Switch | 12. Push Plate Brake Control |
| 5. PCH Auger Drive Switch | 13. Make Up Tool Control |
| 6. PCH Cutter Drive Pressure Gauge | 14. Drive Rotation/PCH Auger Drive Gauge |
| 7. PCH Cutter Drive Switch | 15. Control Panel Power Supply 12 VDC |
| 8. PCH Auger Control | |

GBM 4812A HYDRAULIC CONSOLE (SN 4 & AFTER)

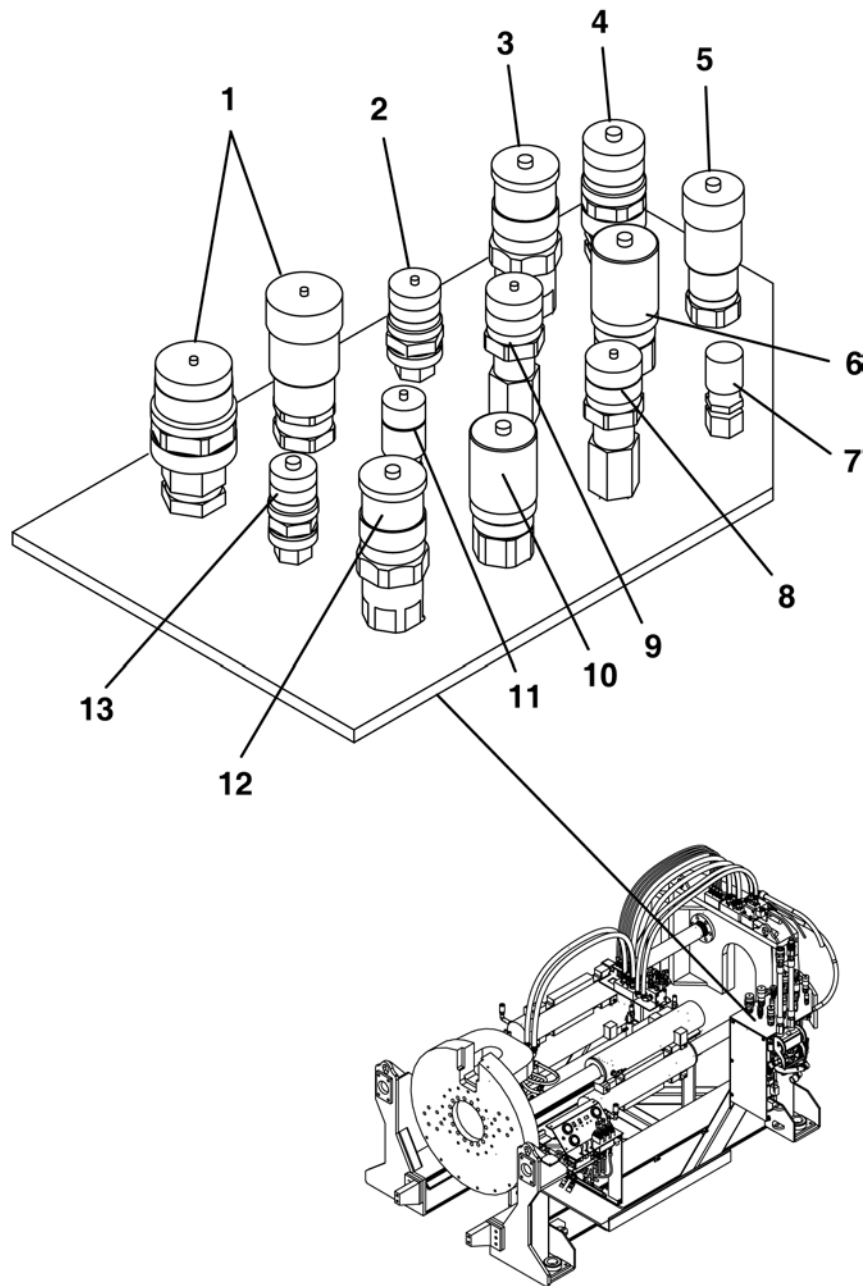

- 1. Tank QD
- 2. Case Drain QD
- 3. Cutter Head Control QD
- 4. P150 Cutter Head Pressure IN QD*
- 5. P150 Pressure Drive Rotation/PCH Auger Drive QD*
- 6. Cutter Head Control QD
- 7. PCH Case Drain QD

- 8. Jacking Pressure QD
- 9. Jacking Load Sense QD
- 10. P275 Pressure IN Drive Rotation/PCH Auger Drive QD
- 11. Rotational Load Sense QD
- 12. P275 Cutter Head Pressure IN QD
- 13. Cutter Head Load Sense QD

* 4812A SN 5 & After)
QD - Quick Disconnect

POWER PACK P275T

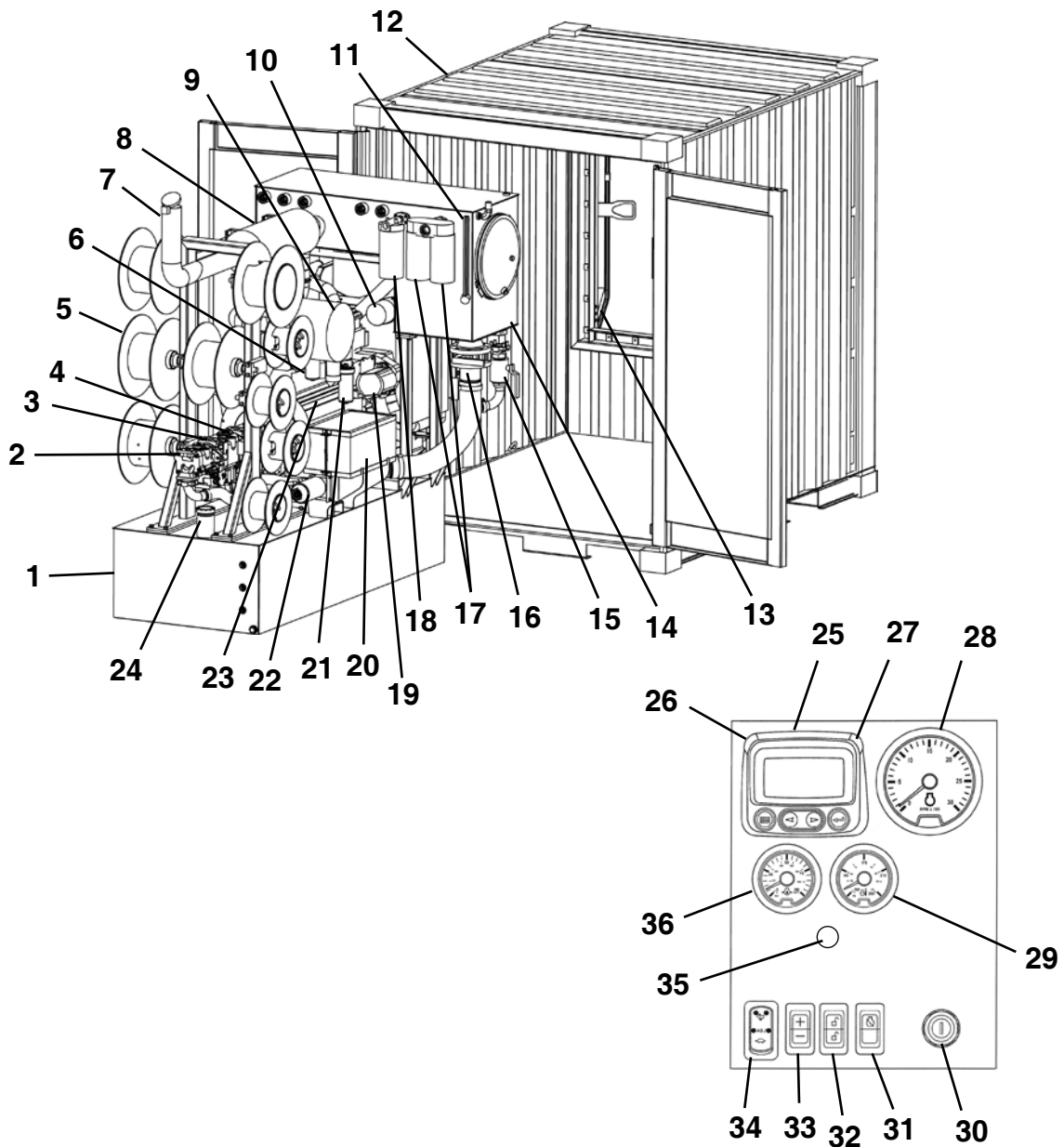

- 1. Fuel Tank
- 2. Jacking Pump
- 3. PCH Cutter Bit Drive Pump
- 4. Drive Rotation/PCH Auger Drive Pump
- 5. Hydraulic Hose Reels
- 6. Fuel Filter
- 7. Exhaust Extension
- 8. Muffler
- 9. Air Cleaner
- 10. Alternator
- 11. Oil Level Sight Gauge With Oil Temperature Gauge

- 12. Container
- 13. Rear Access Door
- 14. Hydraulic Reservoir
- 15. Cooling Pump Suction Valve
- 16. Main Shutoff Valve
- 17. High Flow Return Filter
- 18. Low Pressure Return Filter
- 19. Cooling Pump
- 20. Battery
- 21. Engine Oil Filter
- 22. Hydraulic Suction Manifold
- 23. Engine
- 24. Fuel Fill

- 25. Diagnostic Gauge/Hour Meter
- 26. Warning Indicator Light
- 27. Stop Engine Indicator Light
- 28. Tachometer
- 29. Engine Coolant Temp. Gauge
- 30. Key Start Switch
- 31. Override Shutdown Switch
- 32. Bump Speed Enable Switch
- 33. Speed Select Switch
- 34. High-Low Speed Select Switch
- 35. Monitor Switch*
- 36. Engine Oil Pressure Gauge

* Used on P275T SN 1 - 4 Only

POWER PACK P150Q

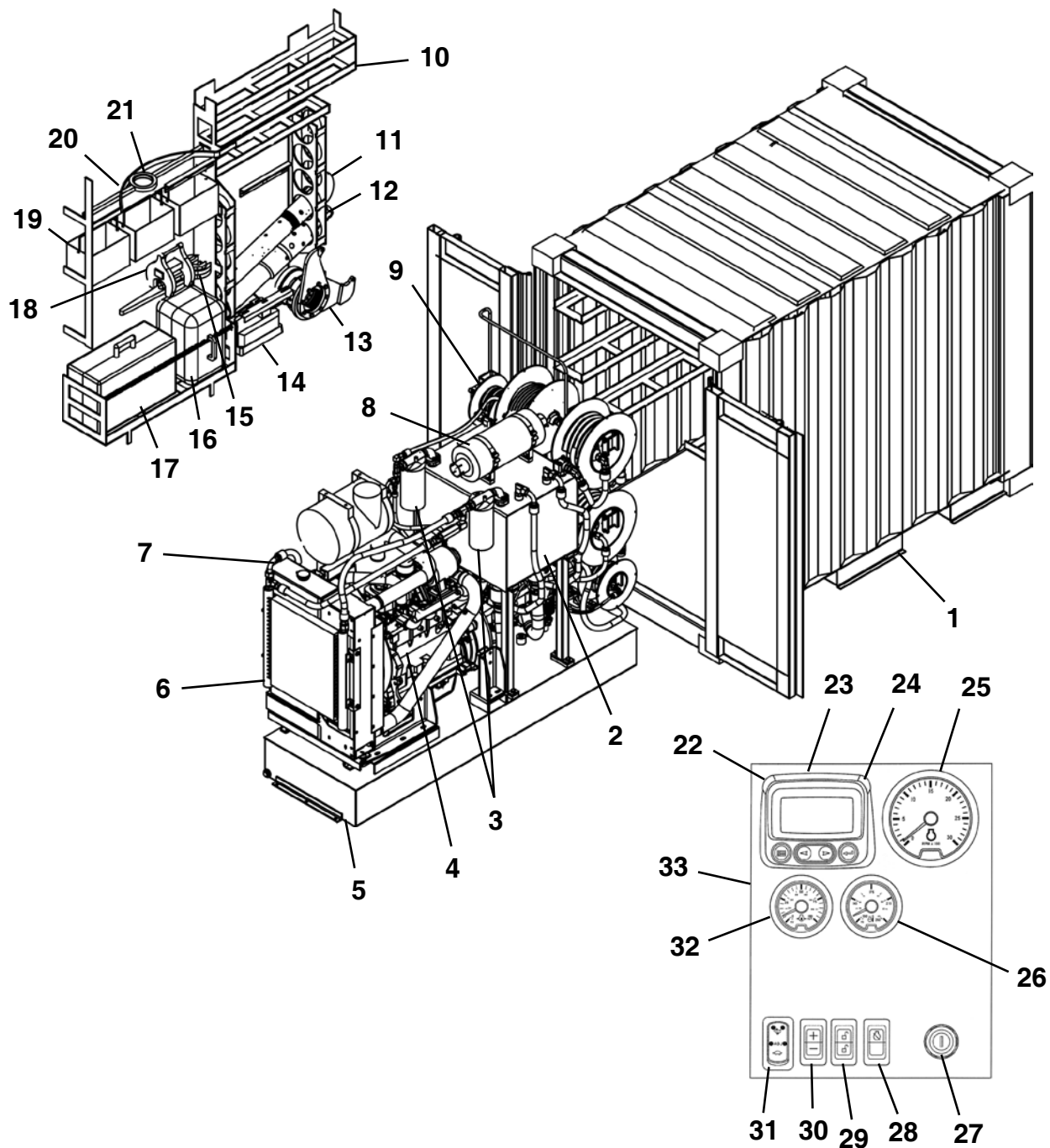

- | | | |
|------------------------------|--------------------------------|--|
| 1. Container | 12. Reaming Head Adapter | 23. Diagnostic Gauge/Hour Meter |
| 2. Hydraulic Reservoir | 13. Dual Tube Breakout Tool | 24. Stop Engine Indicator Light |
| 3. Hydraulic Pressure Filter | 14. Breakout Tool Power Pack | 25. Tachometer |
| 4. Engine - 4 Cyl. 154 HP | 15. Wrench Set | 26. Engine Coolant Temp. Gauge |
| 5. Fuel Tank | 16. Theodolite | 27. Key Start Switch |
| 6. Oil Cooler | 17. Guidance System | 28. Override Shutdown Switch |
| 7. Radiator | 18. Launch Shaft Breakout Tool | 29. Bump Speed Enable Switch |
| 8. Muffer | 19. Storage Basket | 30. Speed Select Switch |
| 9. Hydraulic Hose Reel | 20. Pilot Tube Support Bar | 31. High-Low Speed Select Switch |
| 10. Emergency Stop | 21. Pilot Tube Scraper | 32. Engine Oil Pressure Gauge |
| 11. Steering Head | 22. Warning Indicator Light | 33. Remote Instrument Panel
(Control Pendant) |

GUIDANCE SYSTEM

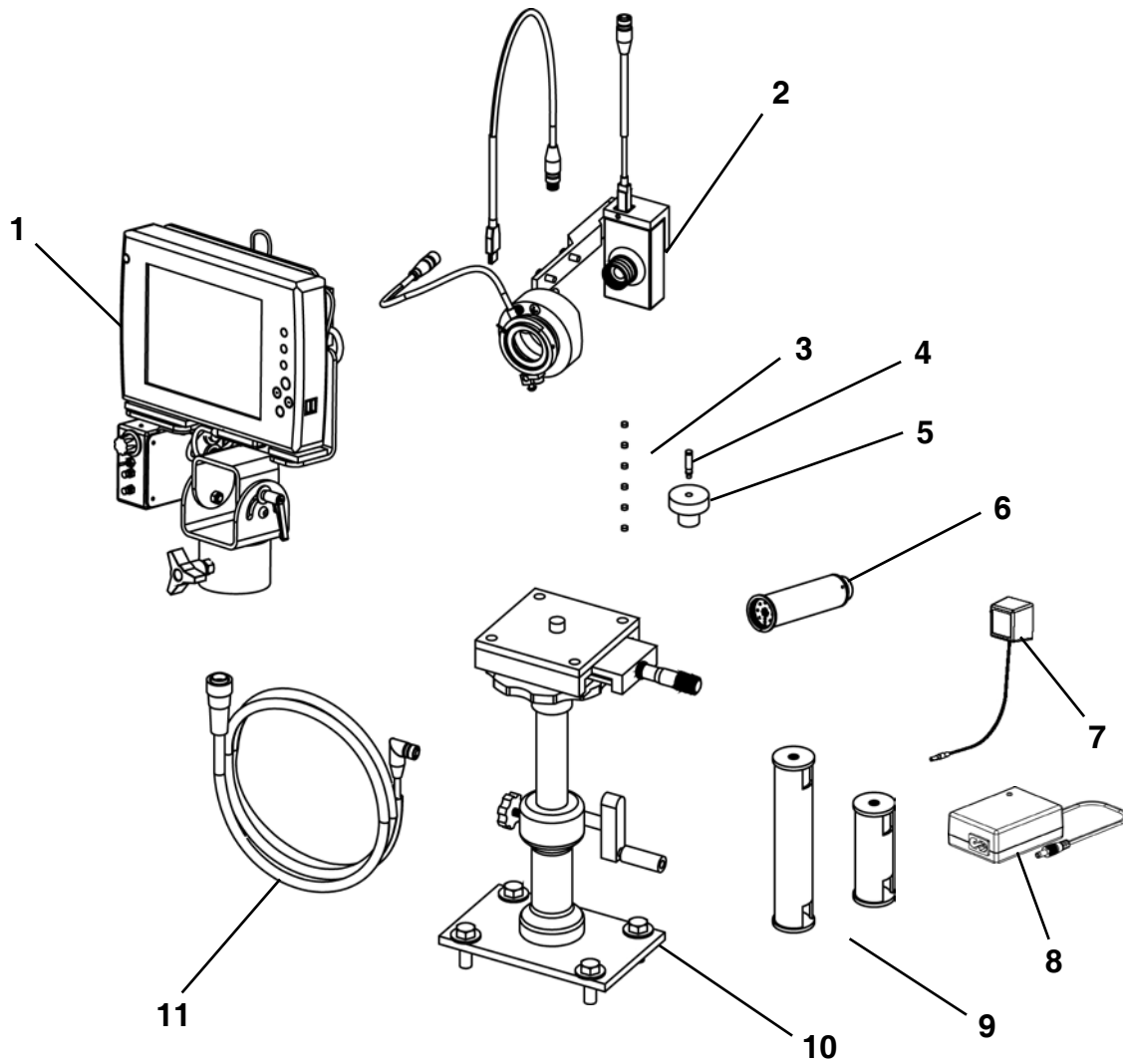

- 1. Tablet PC With Docking Station
- 2. Camera Optics
- 3. Laser Bore Sight Batteries
- 4. Laser Bore Sight
- 5. Alignment Holder
- 6. Target

- 7. Overnight Charger
- 8. Smart Charger
- 9. Column Extensions: 6" & 12"
- 10. Theodolite Stand
- 11. Guidance Power Cable

TABLET PC ASSEMBLY WITHOUT REMOTE FOCUS (SN FA42035F-86 & BEFORE)

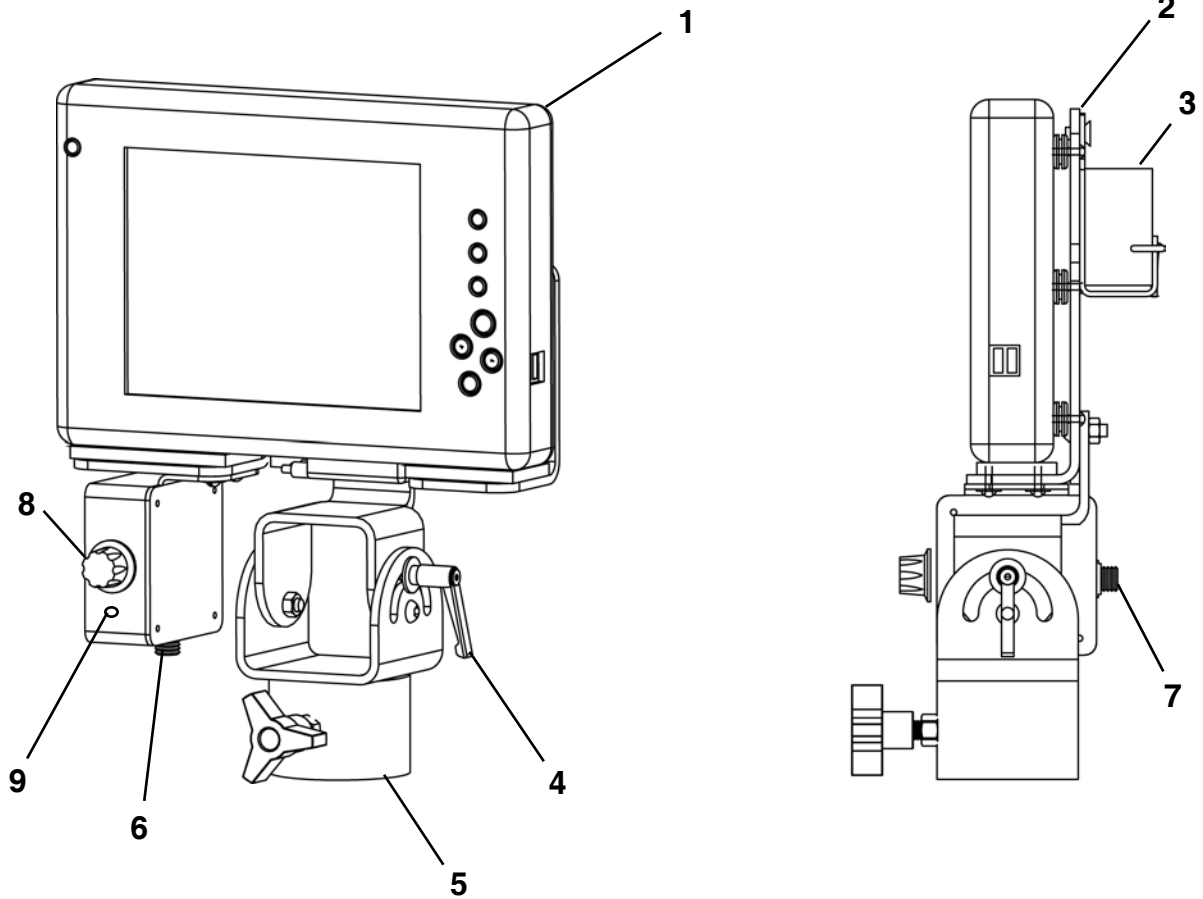

- 1. Tablet PC
- 2. Docking Station
- 3. Power Adapter
- 4. Monitor Tilt Adjustment
- 5. Monitor Top Mount

- 6. Power In Cable Connection
- 7. LED Cable Connection
- 8. LED Brightness Control
- 9. Camera Power Indicator

* Some units have been updated with the Remote Focus Kit option. See Tablet PC Assembly With Remote Focus Kit (SN FA42035F-86 & Before).

REMOTE FOCUS KIT (SN FA42035F-86 & BEFORE)

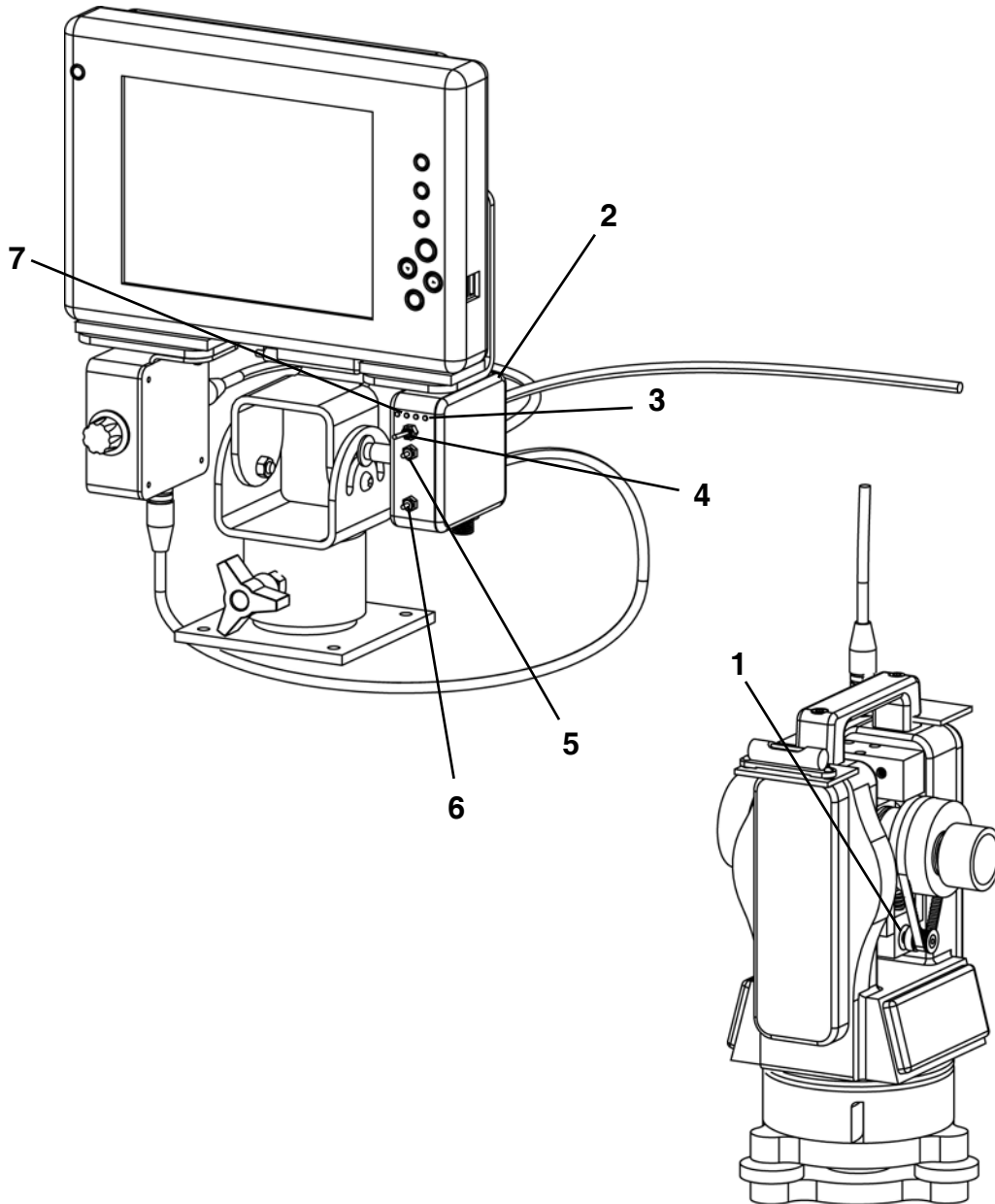

- 1. Drive Motor
- 2. Remote Focus Control Box
- 3. LED Limit Light
- 4. SLOW/FAST Focus Speed Switch

- 5. IN
- 6. OUT
- 7. LED Run

TABLET PC ASSEMBLY WITH REMOTE FOCUS (SN FA42035F-87 & AFTER)

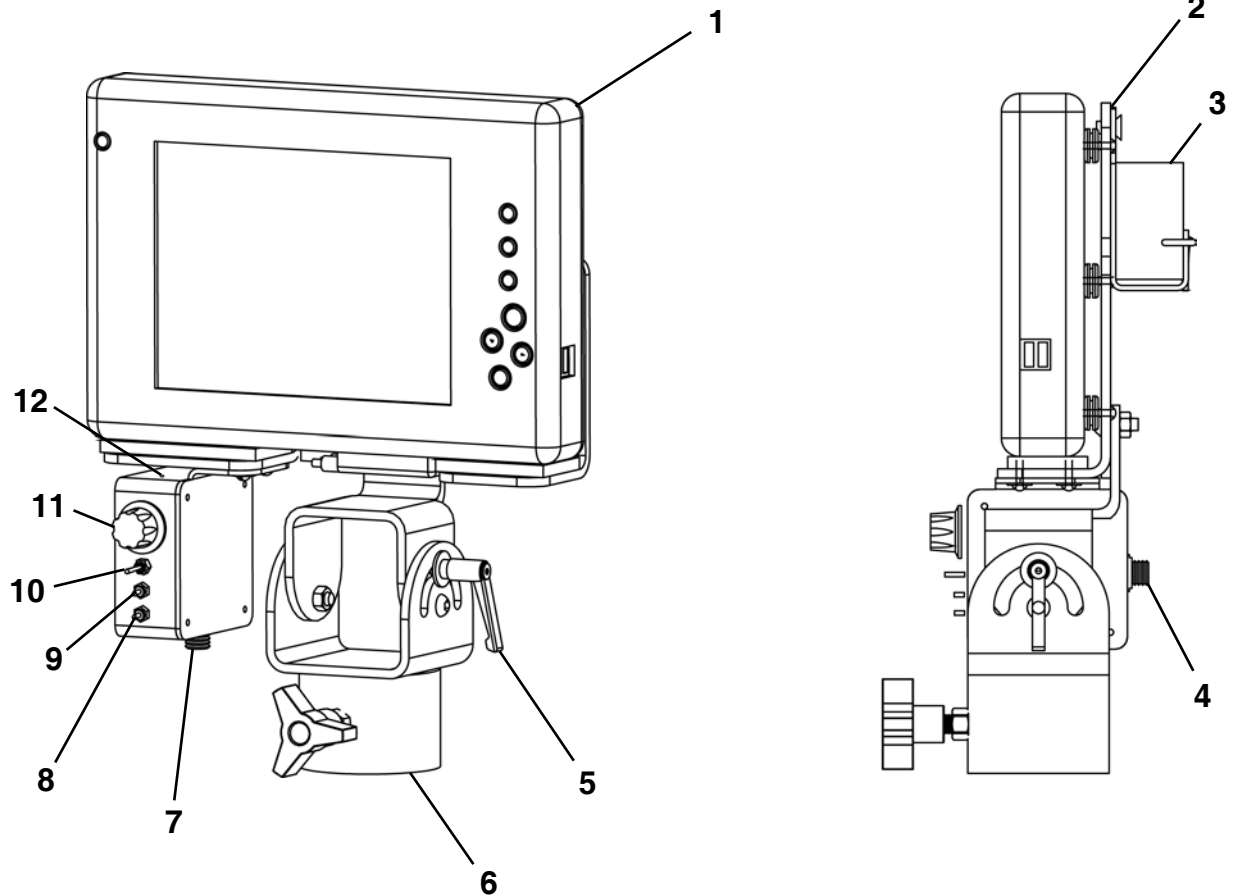

- | | |
|----------------------------|----------------------------------|
| 1. Tablet PC | 7. Power In Cable Connection |
| 2. Docking Station | 8. OUT Focus |
| 3. Power Adapter | 9. IN Focus |
| 4. LED Cable Connection | 10. SLOW/FAST Focus Speed Switch |
| 5. Monitor Tilt Adjustment | 11. LED Brightness Control |
| 6. Monitor Top Mount | 12. Camera Power Indicator |

TABLET PC CONTROLS

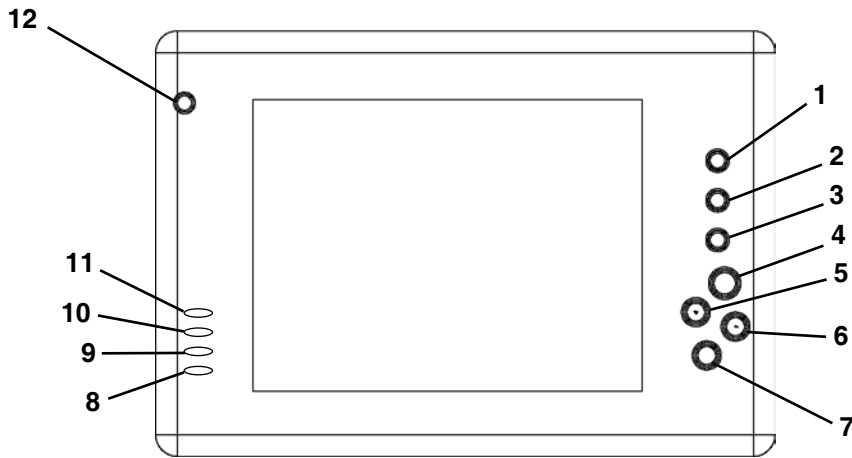

- 1. Rotate Screen
- 2. Windows Task Manager
- 3. Select Up
- 4. Select Down (Enter)
- 5. Up
- 6. Down

- 7. Function Key
- 8. Power Light
- 9. Charge Light
- 10. Hard Drive Light
- 11. Wireless Light
- 12. Power

CAMERA OPTICS

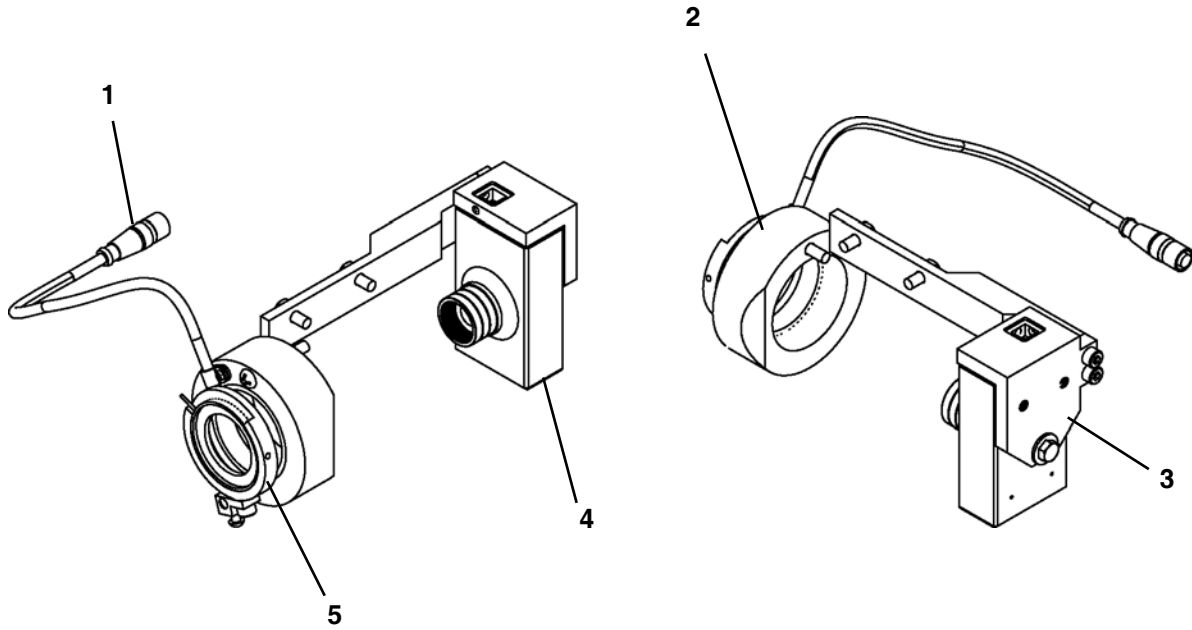

- 1. LED Cable
- 2. Counterweight
- 3. Camera Bracket

- 4. Video Camera
- 5. Iris Mount

THEODOLITE

NOTICE

For more information, refer to your theodolite manual.

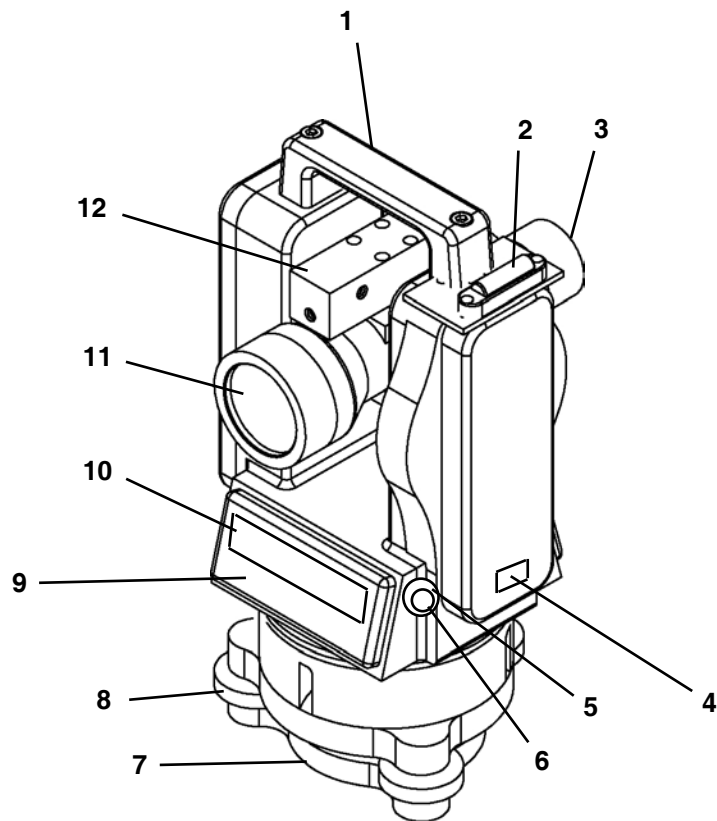

- | | |
|----------------------------------|-------------------|
| 1. Carrying Handle | 7. Base Plate |
| 2. Level | 8. Leveling Screw |
| 3. Telescope Eyepiece | 9. Keyboard |
| 4. Power Switch | 10. Display |
| 5. Optical Plummet Focusing Ring | 11. Objective |
| 6. Optical Plummet | 12. Camera Mount |

NOTES

POWERED CUTTER HEAD 20 - 22.5 - 28.5

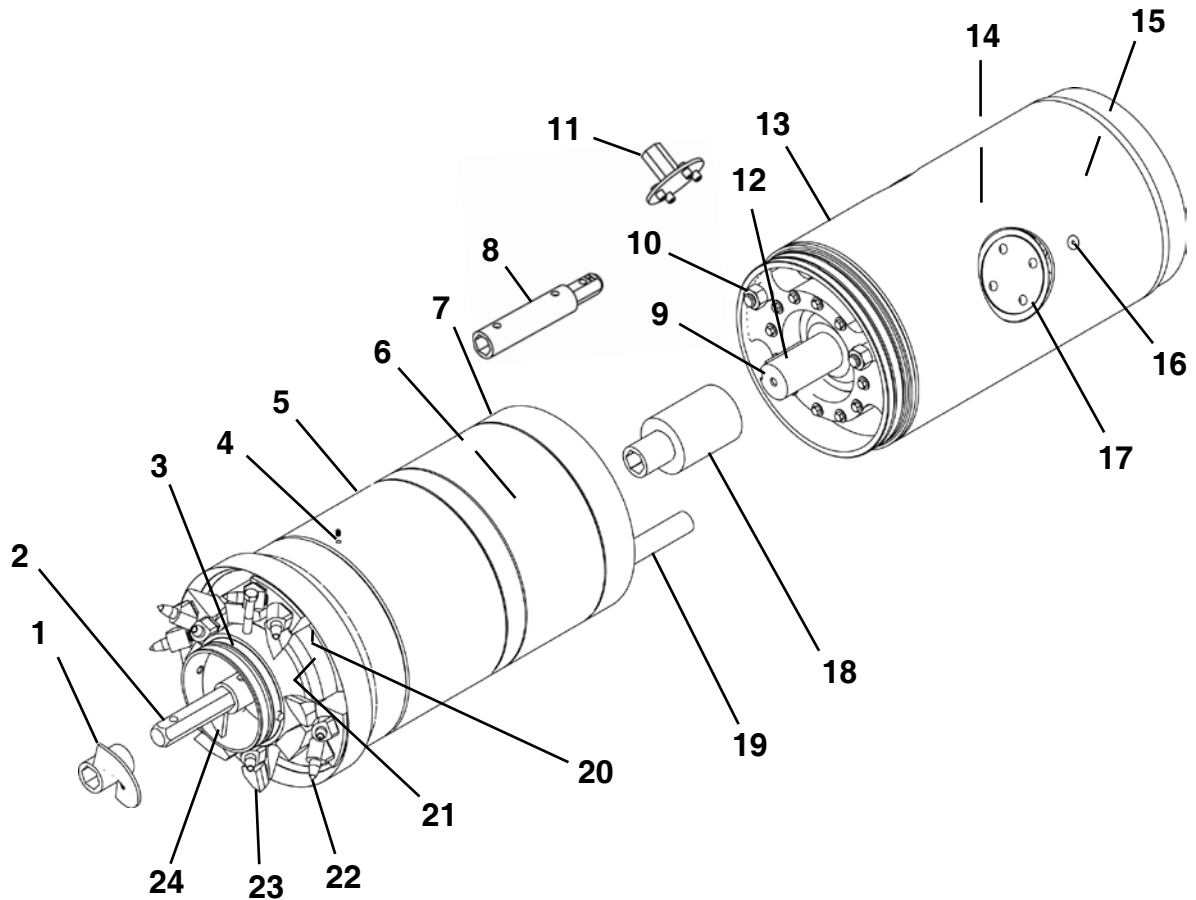

- | | |
|----------------------------|--------------------------------|
| 1. Lead Auger | 13. Rear Section |
| 2. Hex Connector | 14. Auger Drive Gear Box |
| 3. PCH Auger Casing | 15. Hydraulic Drive Motor |
| 4. External Grease Port | 18. Lubrication Port (3) |
| 5. Front Section | 17. Port Hole |
| 6. Hydraulic Motor | 18. Auger Drive Shaft Coupling |
| 7. Bell End | 19. Hydraulics |
| 8. GBM Gear Box Connection | 20. Jetting Ports (3) |
| 9. Drive Shaft Keyway | 21. Mixing Chamber |
| 10. Alignment Pins | 22. Cutter Bullet Bit |
| 11. Port Hole Wrench | 23. Cutter Dirt Bit |
| 12. Auger Drive Shaft | 24. PCH Auger Section |

POWERED CUTTER HEAD 36 & 44

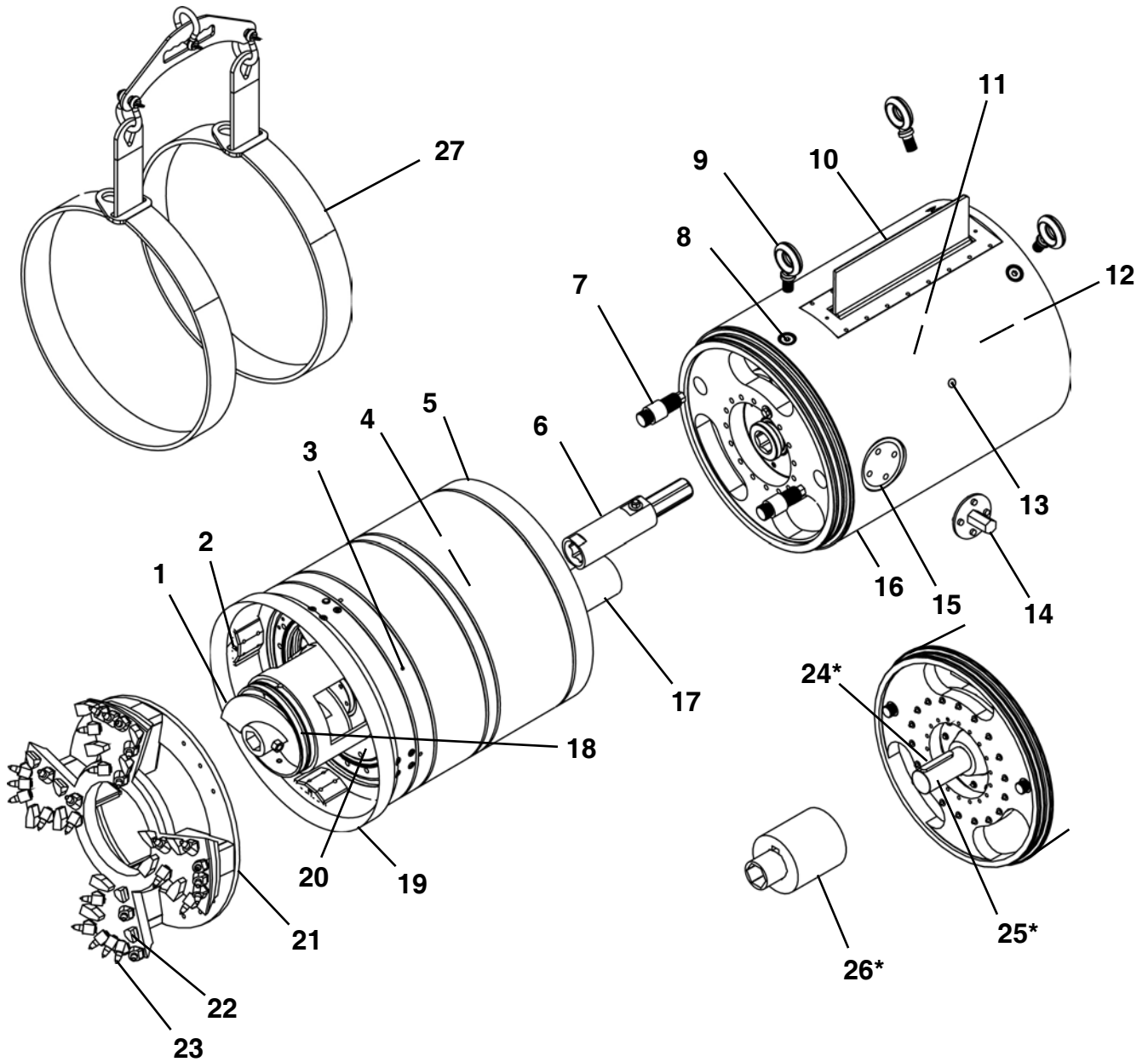

- | | |
|---------------------------------|------------------------------------|
| 1. PCH Auger Section | 15. Port Hole |
| 2. Jetting Port (4) | 16. Rear Section |
| 3. External Grease Port | 17. Hydraulics |
| 4. Hydraulic Motors | 18. PCH Auger Casing |
| 5. Bell End | 19. Front Section |
| 6. Gear Box Connector Extension | 20. Mixing Chamber |
| 7. Alignment Pins | 21. PCH Cutter Head |
| 8. Lifting Lugs | 22. Cutter Dirt Bit |
| 9. Lifting Eye | 23. Cutter Bullet Bit |
| 10. Dirt Wing | *24. Drive Shaft Keyway |
| 11. Auger Drive Gear Box | *25. Auger Drive Shaft |
| 12. Hydraulic Drive Motors | *26. Coupler |
| 13. Lubrication Port (3) | 27. Lifting Straps - Front Section |
| 14. Port Hole Wrench | |

* PCH 44 SN 1 and 2 Only

GBM TOOLING - THREE STEP METHOD for 11" - 16" OD Pipe

1. Pilot Tube Installation Tools

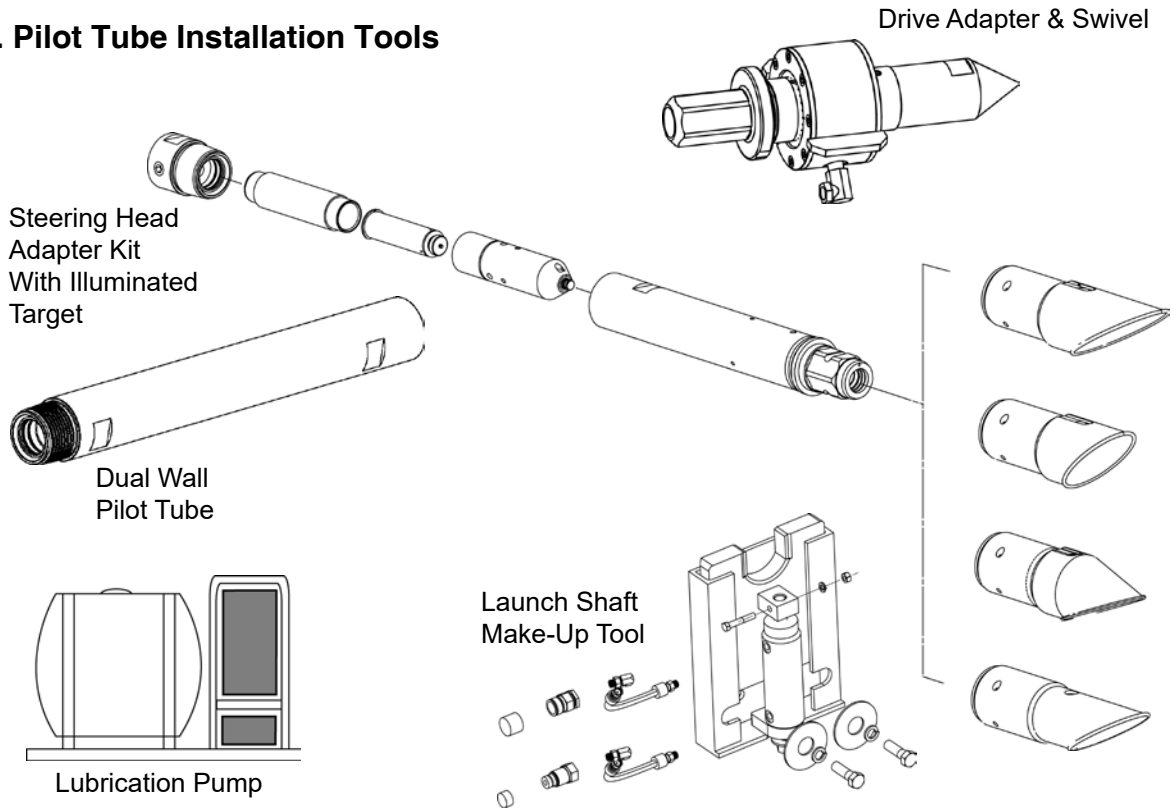

2. Pilot Tube Reception Shaft Removal Tools

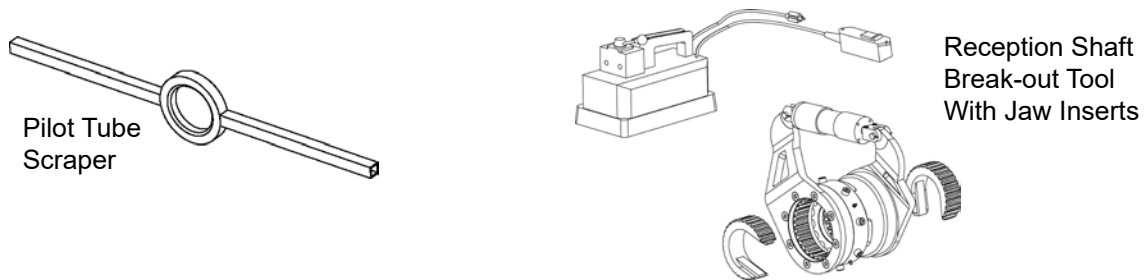

3. Pilot Tube Launch Shaft Pull Back Tools

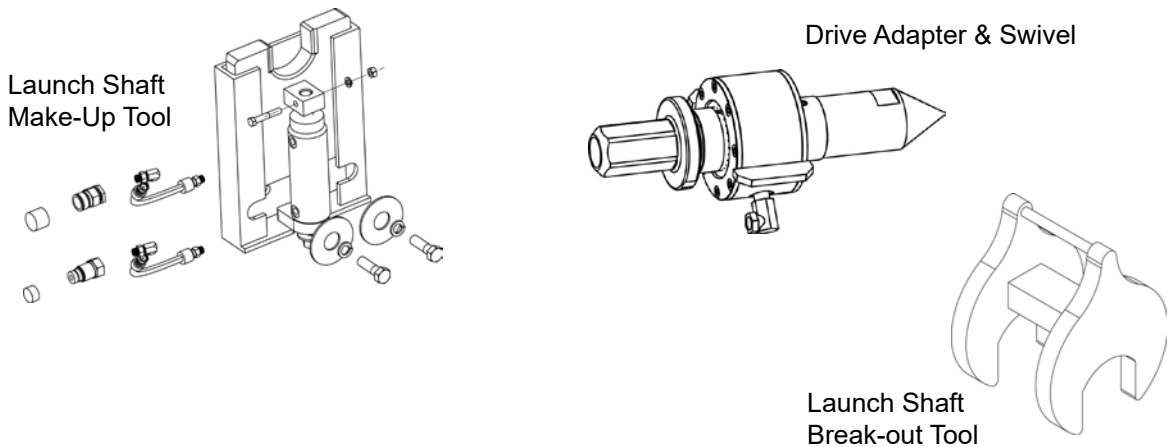

4. Upsizing Tool: Reaming Head Thrust Casing Installation Tools

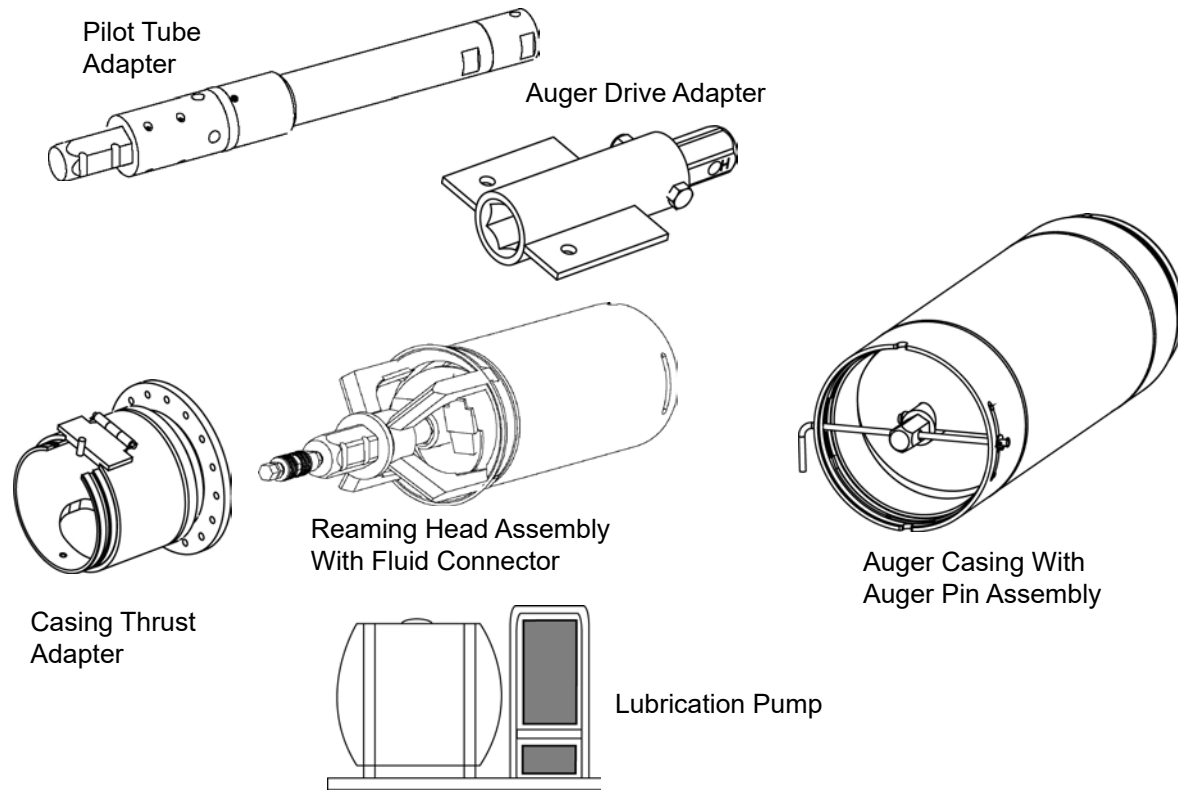

5. Pipe Installation Tools

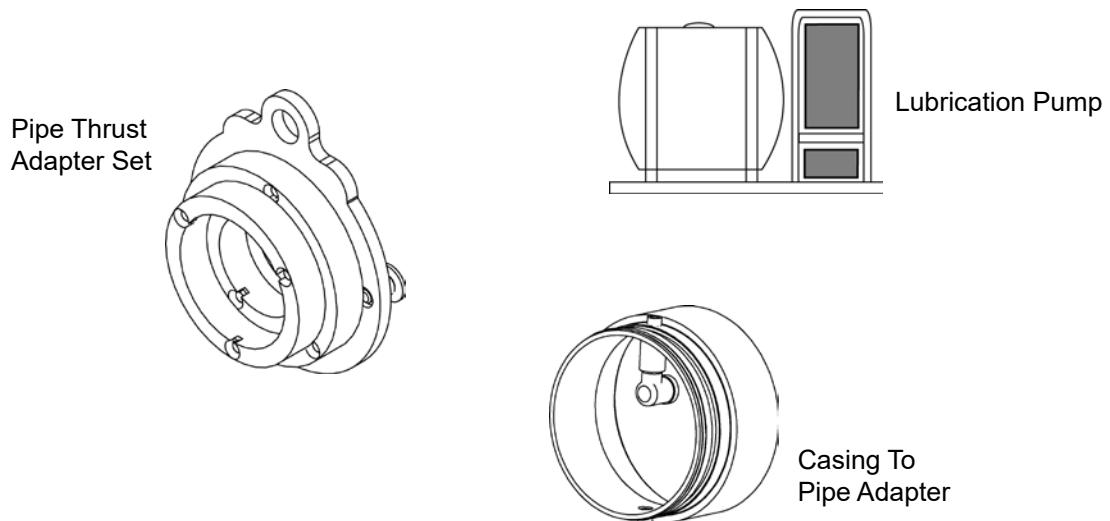

GBM TOOLING - THREE STEP METHOD WITH POWERED CUTTER HEAD (PCH20 - 22.5 - 28.5) for 20" - 35.5" OD Pipe

1. Pilot Tube Installation Tools

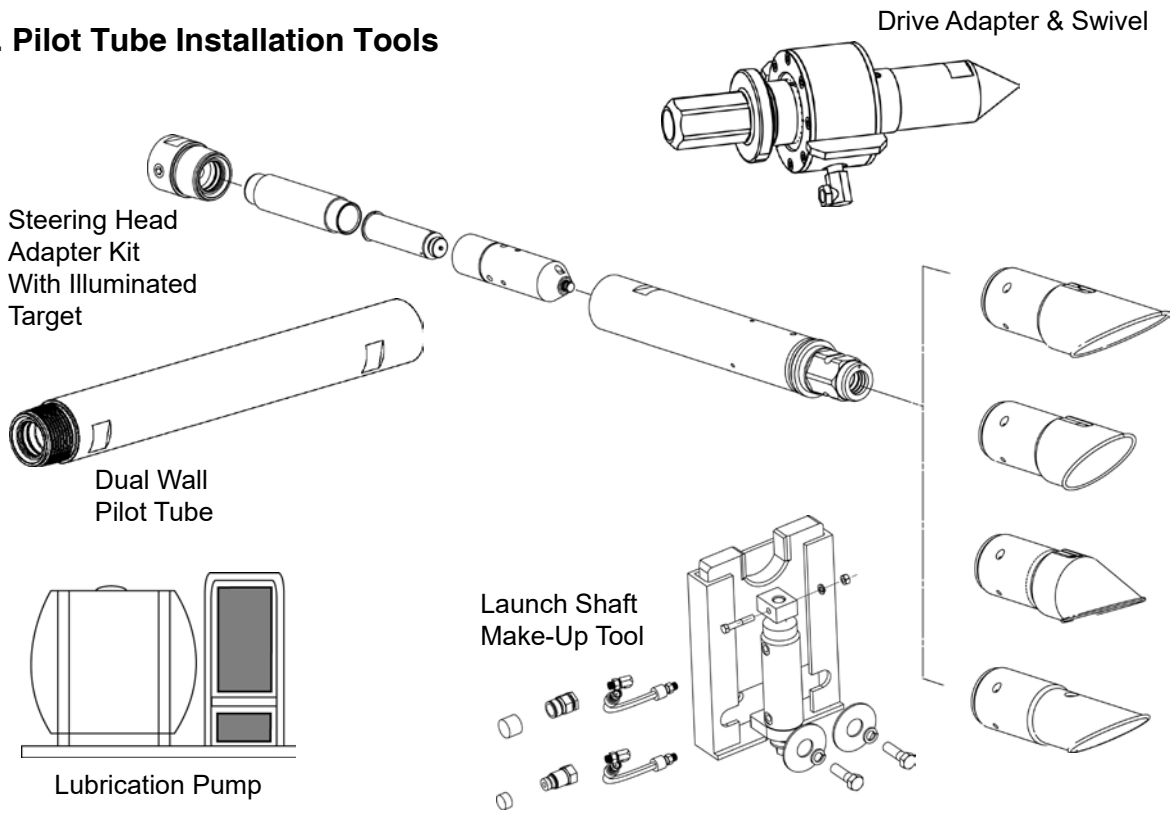

2. Pilot Tube Reception Shaft Removal Tools

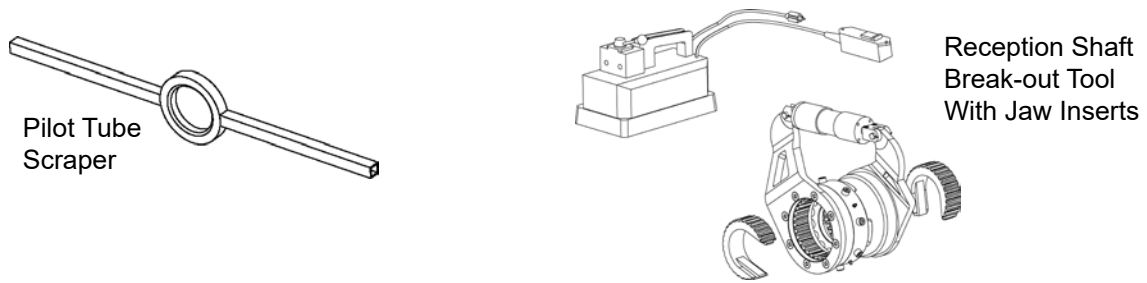

3. Pilot Tube Launch Shaft Pull Back Tools

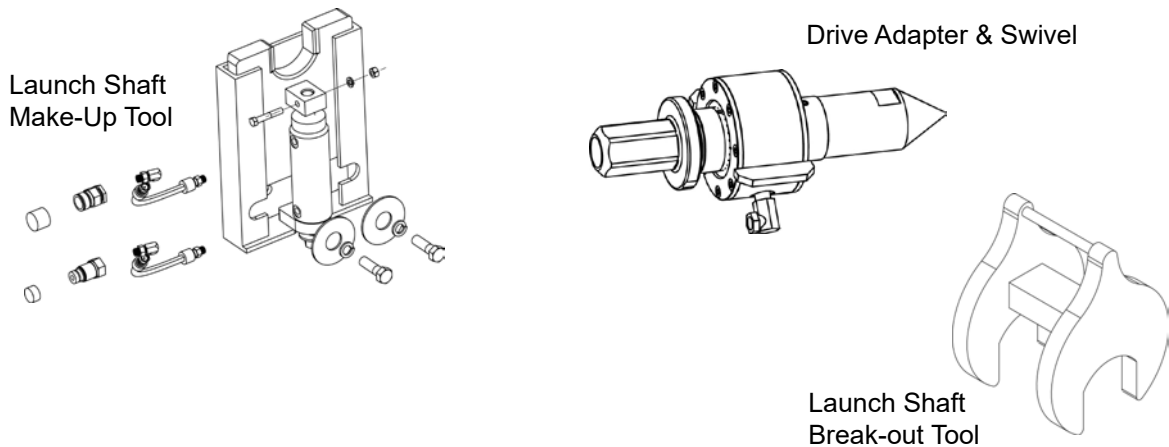

4. Upsizing Tool: Reaming Head Thrust Casing Installation Tools

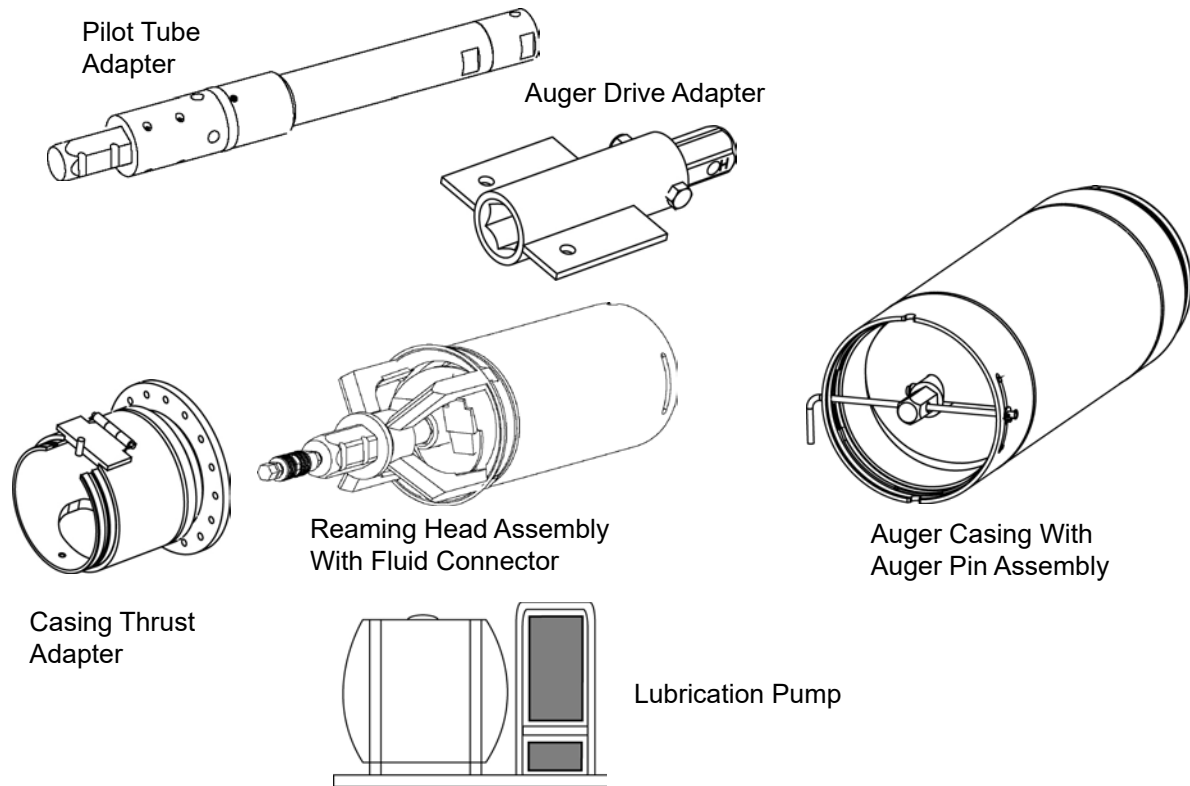

5. Upsizing Tool: Powered Cutter Head Installation Tools

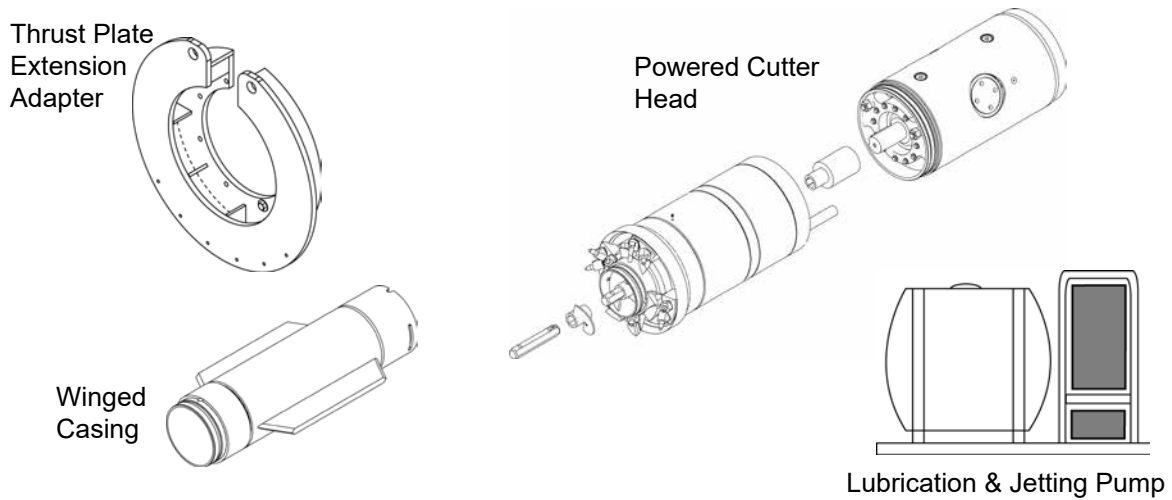

6. Pipe Installation Tools

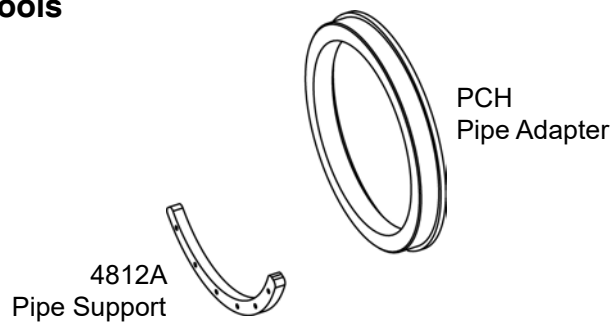

GBM TOOLING - THREE STEP METHOD WITH POWERED CUTTER HEAD (PCH36 - 44) for 36" - 48" OD Pipe

1. Pilot Tube Installation Tools

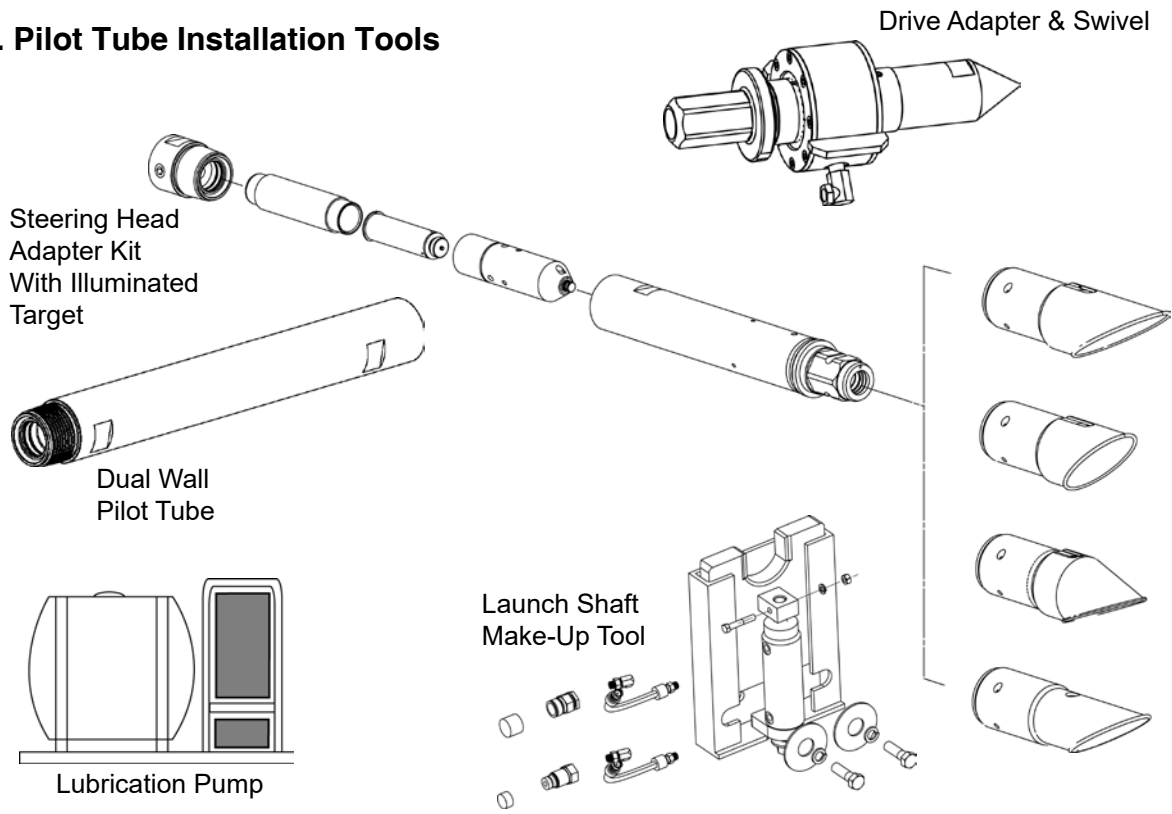

2. Pilot Tube Reception Shaft Removal Tools

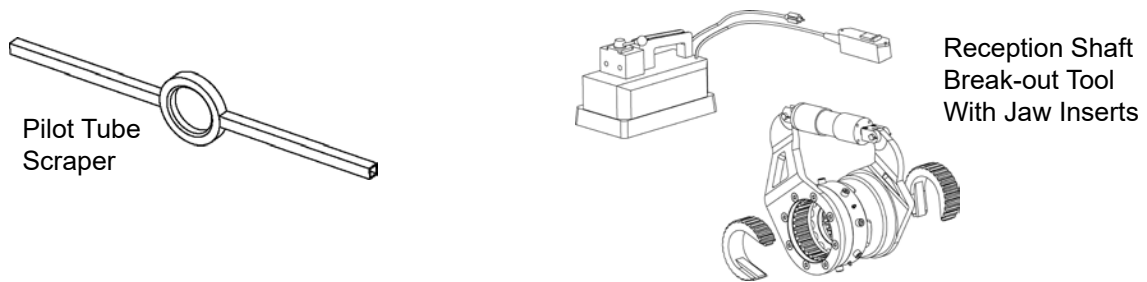

3. Pilot Tube Launch Shaft Pull Back Tools

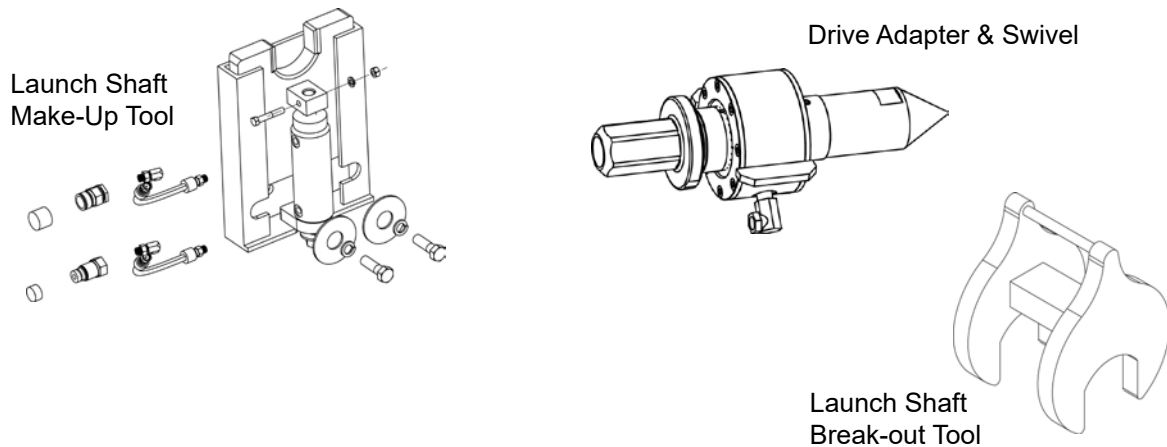

4. Upsizing Tool: Reaming Head Thrust Casing Installation Tools

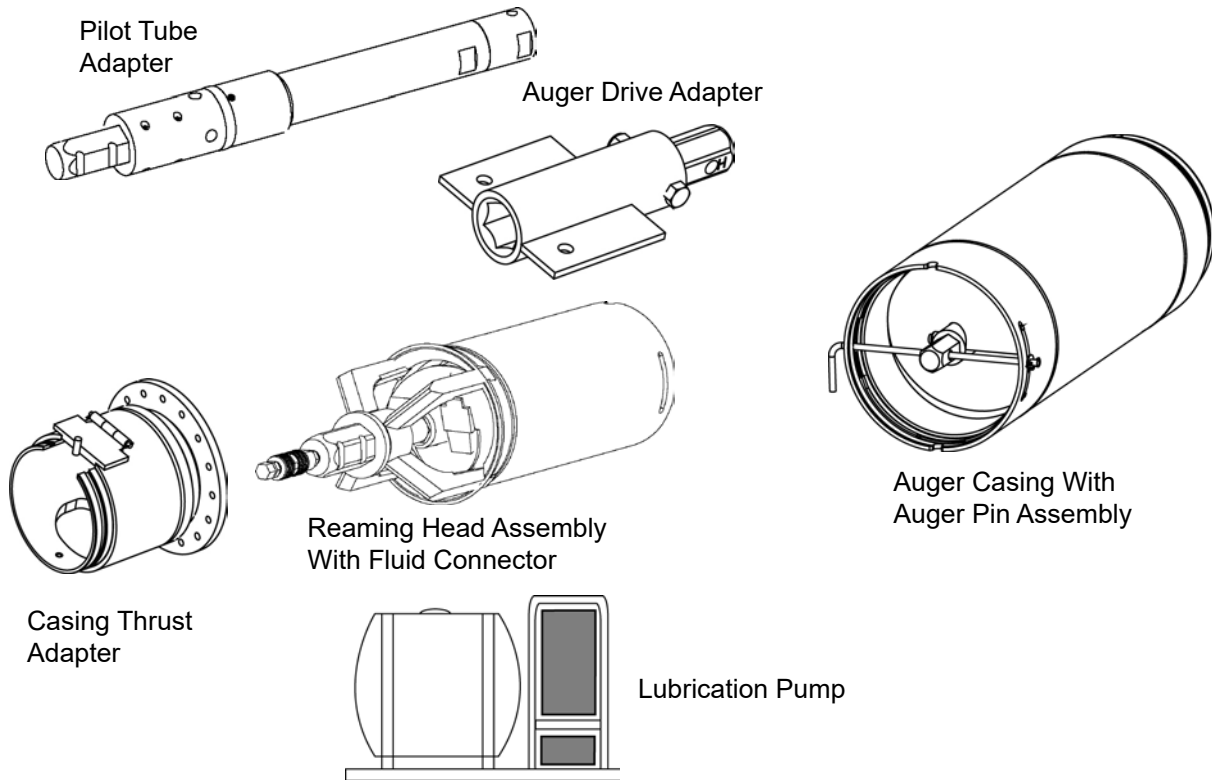

5. Upsizing Tool: Powered Cutter Head Installation Tools

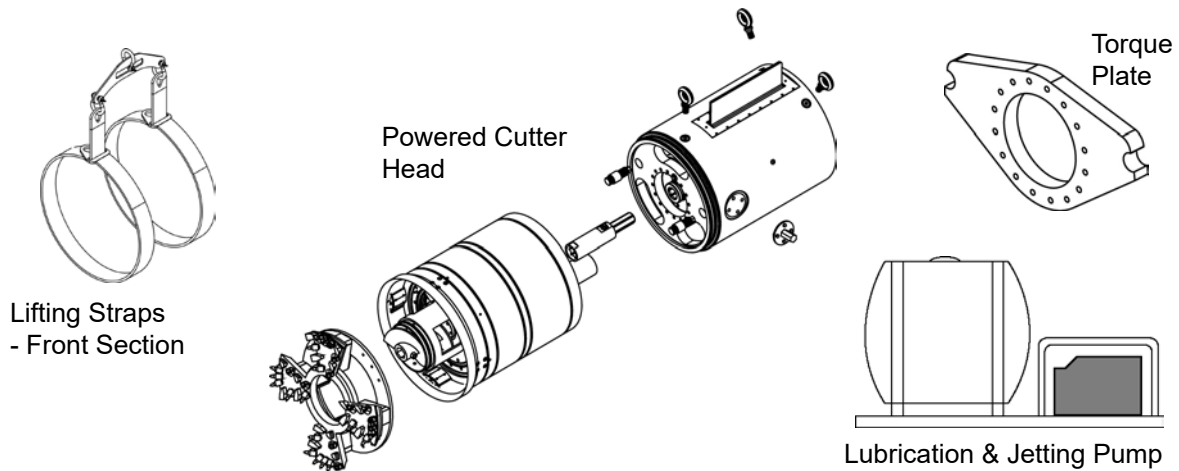

6. Pipe Installation Tools

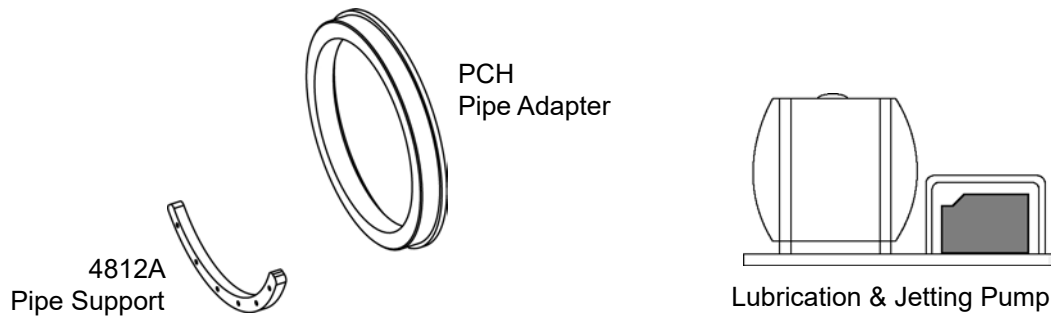

NOTES

Controls & Instruments

THRUST CYLINDER CONTROL

Use the thrust cylinder control (A) to extend and retract the frame thrust cylinders.

- Extend Cylinders - Push lever Forward
- Retract Cylinders - Pull lever Back

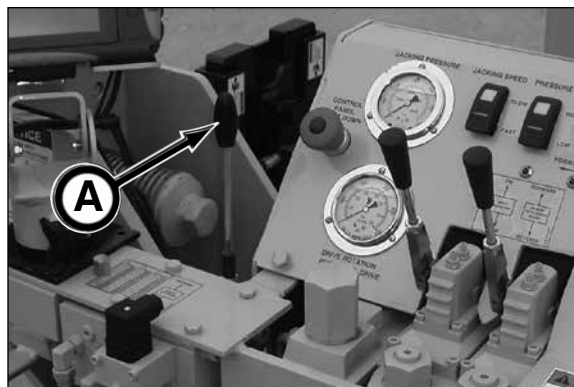

SN 1 -3

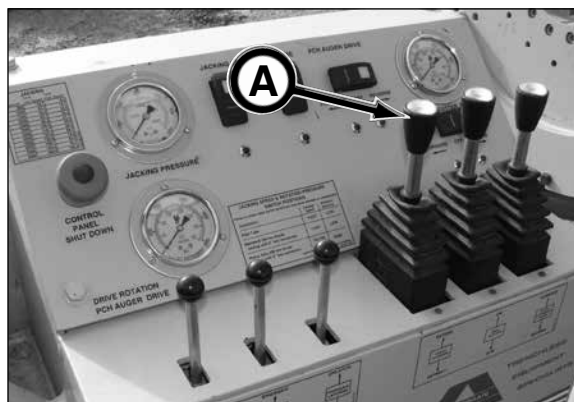

SN 4 & After

DRIVE ROTATION CONTROL

The drive rotation control (B) is used to rotate the steering head, pilot tube, and augers in the clockwise direction.

NOTICE Always rotate the pilot tube CW (clockwise). Rotating the pilot tubes CCW (counterclockwise) will unthread the pilot tubes in the pipeline resulting in unrecoverable pilot tubes.

Use CCW rotation **ONLY** when the steering head adapter or pilot tube is locked into the make up tool for removal from the gear box drive adapter or when cleaning the auger casings.

- Clockwise (CW) Rotation - Push lever Forward
- Counter-Clockwise (CCW) Rotation - Pull lever Back

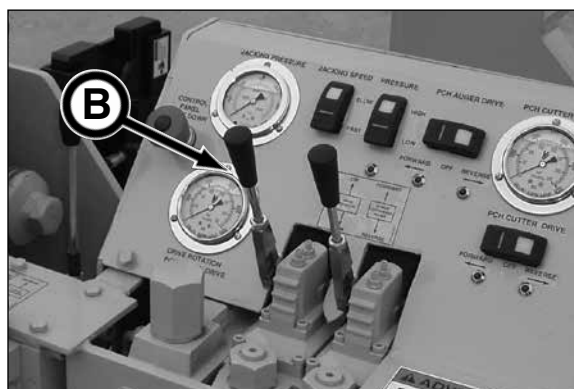

SN 1 -3

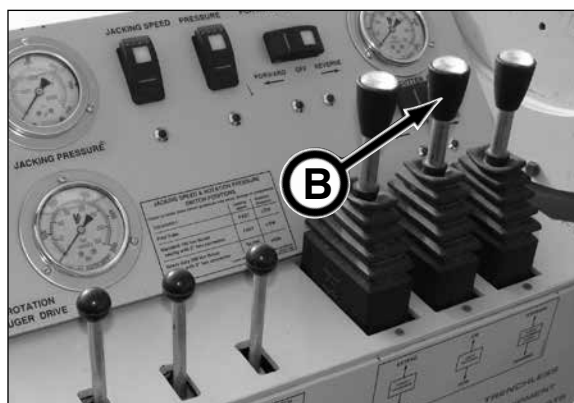

SN 4 & After

POWERED CUTTER HEAD - AUGER CONTROL

The auger control (A) is used to rotate the powered cutter head auger.

Always rotate the PCH auger in the reverse or counter-clockwise (CCW) direction. This will move the spoils to the reception shaft.

NOTICE Rotating the PCH auger in the wrong direction may damage equipment from spoils building up in the mixing chamber.

Forward (counterclockwise rotation) - Push lever Forward

Reverse (clockwise rotation) - Pull lever Back

There is also an electric/hydraulic rotation switch (B) to control the rotation of the PCH auger. Selecting Forward or Reverse will rotate the PCH auger at full speed without the need to operate the manually-operated hydraulic control (A).

NOTICE The LED light (C) below the switch will illuminate indicating the function is in operation.

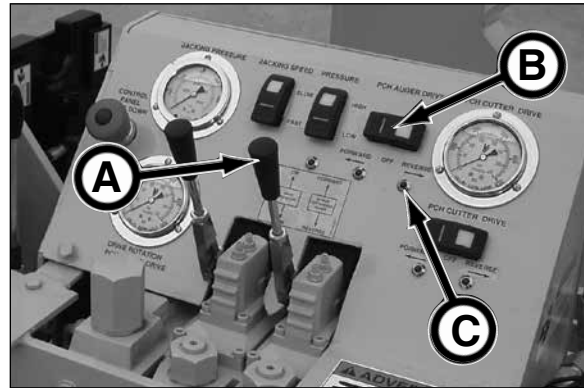

SN 1 -3

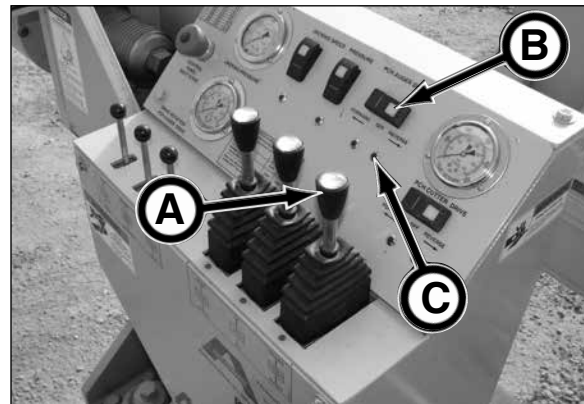

SN 4 & After

MAKE UP TOOL CONTROL

The hydraulic make up tool control (D) is used to raise and lower the make up tool hydraulic cylinder.

The make up tool (see inset) holds each section of the pilot tubes as they are being tightened and installed in the launch shaft.

In pull back operation, the make up tool is used to separate (unlock) the pilot tubes in the launch shaft.

	SN 1 - 3	SN 4 & After
Lock	- Pull lever up	Push forward
Unlock	- Push lever down	Pull backward

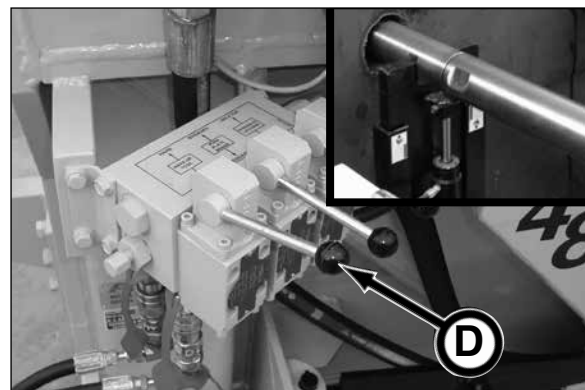

SN 1 -3

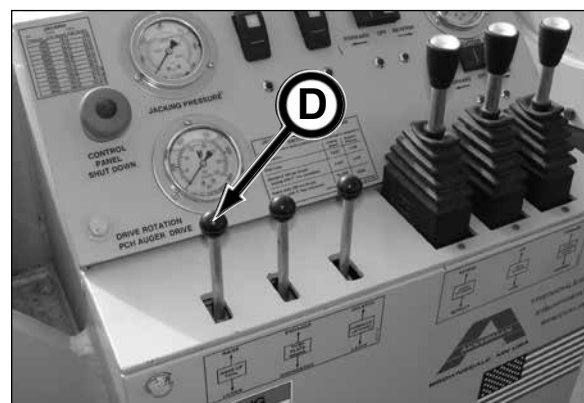

SN 4 & After

PUSH PLATE BRAKE CONTROL

The push plate brake control (A) engages and disengages the brake (B) on the push plate (C) or frame thrust block to permit the relatching of the thrust cylinders when installing two meter pipe.

The relatching of the thrust cylinders allows an additional 20" (508 mm) of frame travel that is necessary to push two meter pipe.

When installing pilot tubes, thrust casings and pipe, the brake must be disengaged.

SN 1 - 3

SN 4 & After

Engaged	- Pull lever up	Push forward
Disengaged	- Push lever down	Pull backward

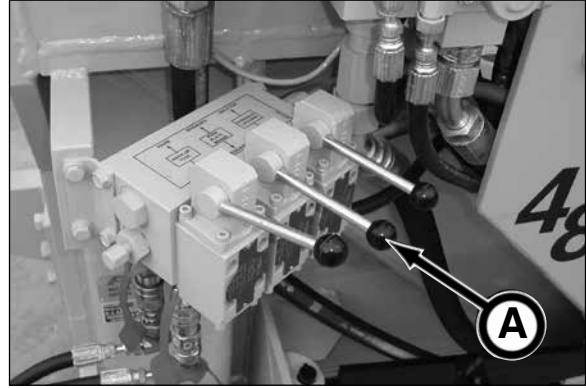

SN 1 - 3

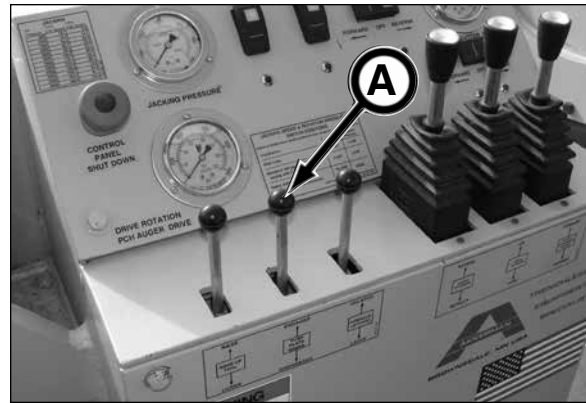

SN 4 & After

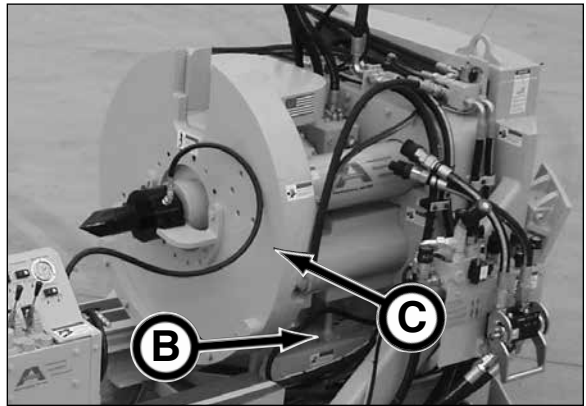

HYDRAULIC LATCHING CONTROL

The latching control (A) is used when installing pipe exceeding 5' (1.5 m) in length. The relatching of the keyhole plates allow an additional 20" (508 mm) of thrust cylinder travel to push the longer pipe the full length of the frame.

The control hydraulically latches and unlatches the keyhole plates from the thrust cylinders by the use of a hydraulic cylinder.

SN 1 - 3

SN 4 & After

Unlatch -	Pull lever up	Push forward
Latch -	Push lever down	Pull backward

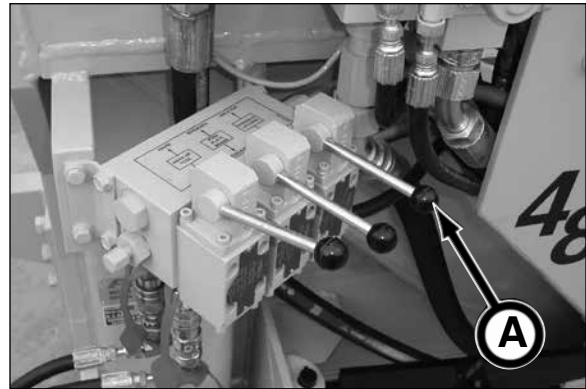

SN 1 - 3

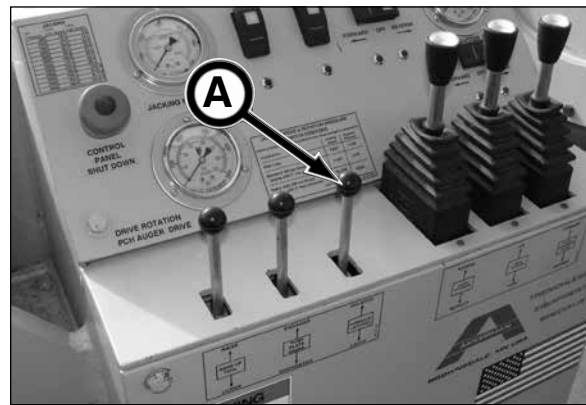

SN 4 & After

NOTICE

The frame keyhole plates must be completely latched into cylinder keyholes before pushing. Failure to do so, could cause machine damage.

The red latch indicator (B) must be flush with the rabbit assembly plates (C). If the red flag is visible, the keyhole plates are not completely latched.

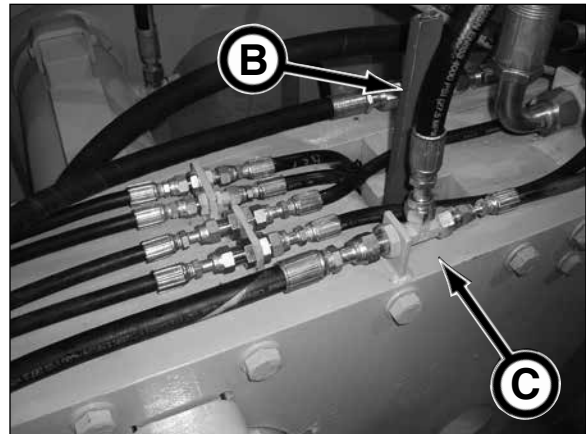

HYDRAULIC PRESSURE GAUGES

Use the pressure gauges to monitor the GBM drive rotation/PCH auger drive (A), jacking thrust (B), and PCH cutter drive (C) pressure.

Drive Rotation/PCH Rotation Drive

Operating range in low pressure is up to 2,000 psi (13.789 MPa) with a maximum pressure of 2,500 psi (17.236 MPa).

Operating range in high pressure is up to 4,000 psi (27.579 MPa) with a maximum pressure of 5,000 psi (34.474 MPa).

Jacking

Operating range in high pressure is up to 5,000 psi (34.474 MPa) with a maximum pressure of 6,000 psi (41.368 MPa).

PCH Cutter Drive

Operating range in high pressure is up to 4,000 psi (27.579 MPa) with a maximum pressure of 5,000 psi (34.474 MPa).

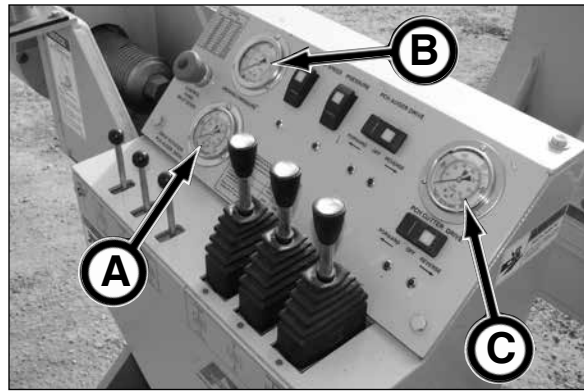

On GBM 4812A Frame

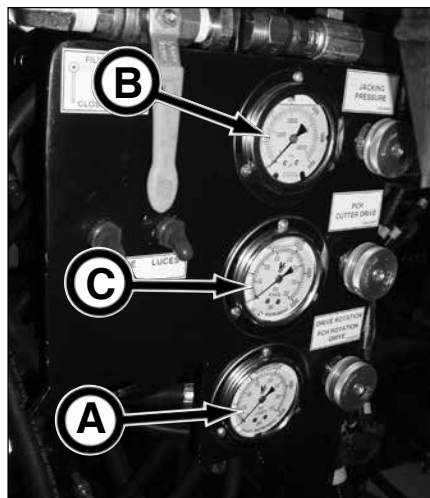

In P275T Power Pack

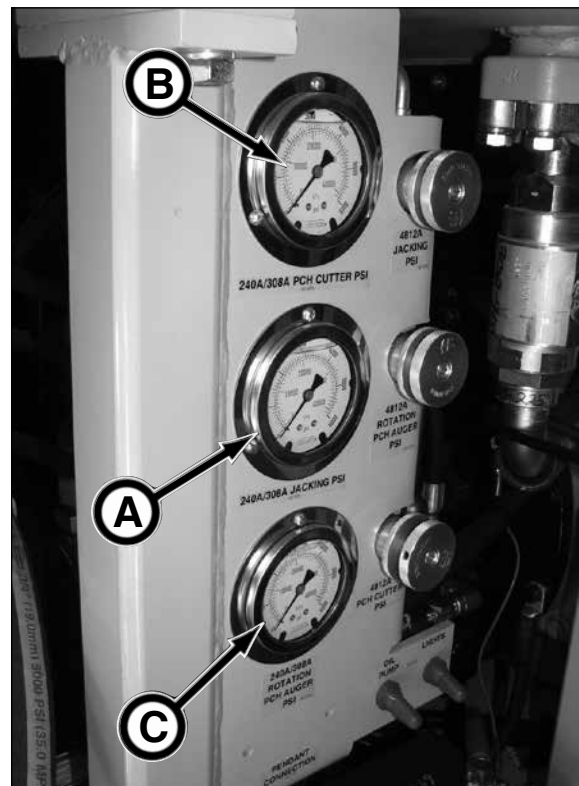

P150Q Power Pack

CONTROL PANEL SHUTDOWN

The control panel shutdown button (D) is used to stop all electrical power to the control panel components: Jacking Speed, Rotation Pressure, PCH Auger Drive, and PCH Cutter Drive. All manual hydraulic functions are still functional. This shutdown button does not affect the P275T or P150Q power pack operation.

Push button IN to shutdown control panel electrical controls.

Pull button OUT to power control panel electrical controls.

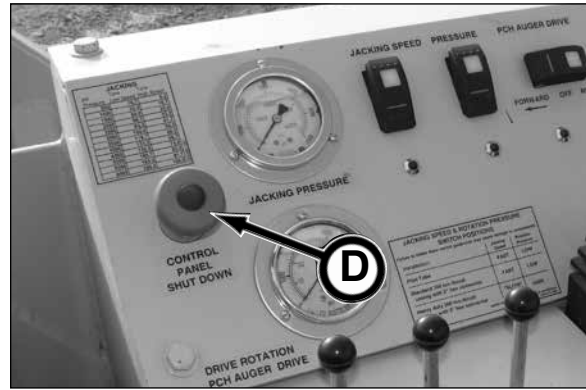

NOTICE This control is typically used when removing the casing and augers in the reception shaft during the PCH/pipe installation of the drive.

POWERED CUTTER HEAD ROTATION CONTROL

There is an electric/hydraulic rotation switch (A) to control the rotation of the PCH cutter head. Selecting Forward or Reverse will rotate the PCH cutter head at full speed without the need to operate the manually-operated hydraulic control (B).

Forward (or clockwise rotation) - Left position

Off - Neutral

Reverse (or counterclockwise rotation) - Right Position

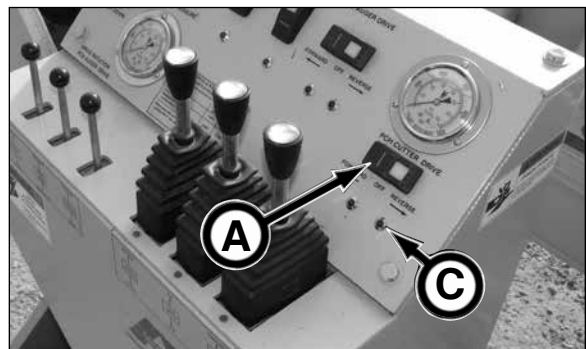

NOTICE The LED light (C) below the switch will illuminate indicating the function is in operation.

The PCH rotation, manual, variable speed control (A) is used to rotate the cutter head on the powered cutter head.

Periodically, change the rotation of the cutter head to maintain the casing alignment guides in the 12 o'clock and 6 o'clock position.

Clockwise (CW) Rotation - Push lever forward

Counter-Clockwise (CCW) Rotation - Pull lever back

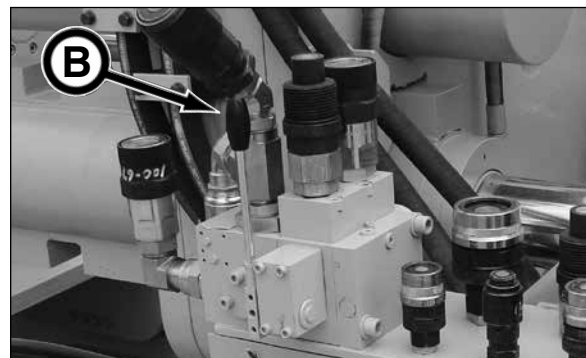

SN 1 - 3

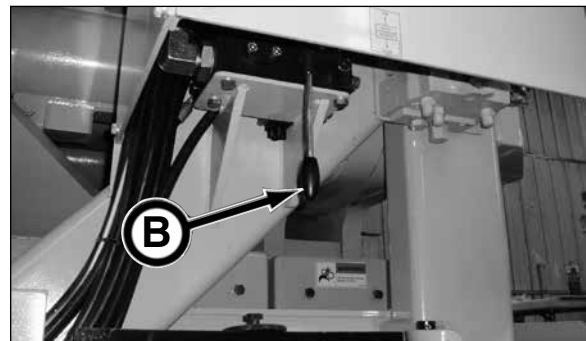

SN 4 & After

JACKING SPEED SWITCH

The jacking speed switch (D) controls the advance speed of the thrust cylinders.

Select Slow or Fast on the jacking speed control as follows:

Fast - 100 ton

Use for pilot tube installation, 11" to 16" casing with 2" hex connection, up to 100 ton maximum rated pipe, and soft ground conditions.

Slow - 200 ton

Use for 16" casing with 3" hex connection, up to 200 ton rated pipe, and hard ground conditions.

NOTICE The thrust cylinder retraction speed is not affected by the Slow/Fast switch. The Slow/Fast switch controls the advance speed.

NOTICE The LED light (E) below the switch will illuminate indicating the function is in operation.

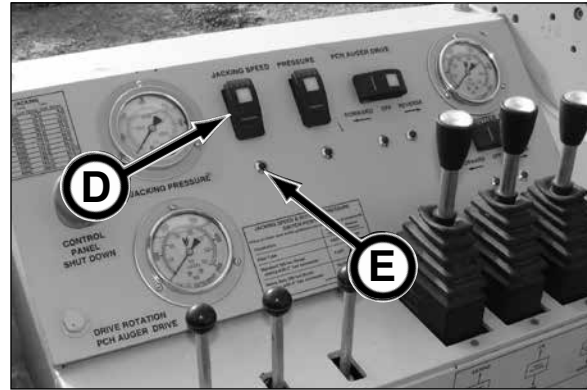

ROTATION PRESSURE SWITCH

The rotation pressure switch (A) is used to control the pressure of the GBM frame auger drive rotation.

Select Low or High on the rotation pressure switch as follows:

Low - 10,500 ft/lb torque

Use for pilot tube installation, 11" to 16" casing with 2" hex connector, up to 100 ton maximum rated pipe, and soft ground conditions.

High - 20,000 ft/lb torque

Use for 16" casing with 3" hex connector, up to 200 ton rated pipe, and hard ground conditions.

NOTICE When using the PCH20 through PCH28.5, the power pack engine speed must be reduced to 1500 rpm to limit the hydraulic flow to match the powered cutter head size.

NOTICE The LED light (B) below the switch will illuminate indicating the function is in operation.

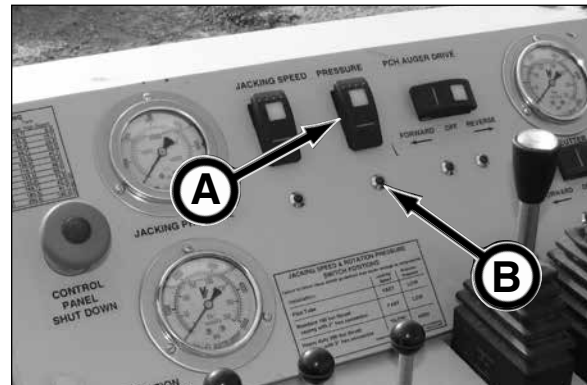

THEODOLITE & CAMERA

The theodolite (C) is used to align and maintain line and grade with a designed accuracy of .25 inch (6.35 mm) up to 300 feet (91 m).

The camera (D) mounted on the theodolite, transfers the digital image of the illuminated target (in the steering head) to the tablet PC monitor.

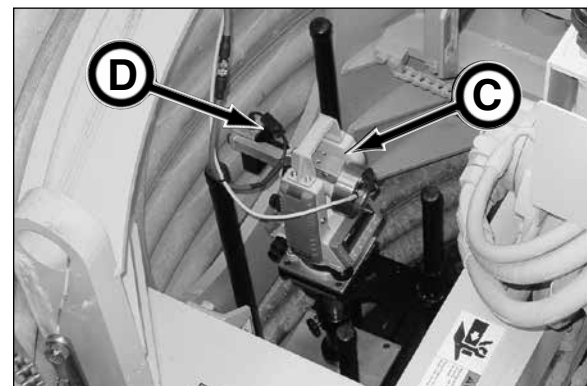

TABLET PC MONITOR

The target displayed on the tablet PC monitor allows the operator to observe the location of the target in the pipeline in relation to the cross hairs on the monitor.

Any corrections made to line and/or grade will be visible on the monitor.

On & Off Control

To turn on (boot up) tablet PC, depress power button (A). The GBM_System program automatically loads once the Windows® operating system is loaded.

NOTICE If a DOS screen appears, the Windows operating system did not load properly. Refer to “Problem: Windows operating system and the Akkerman GBM_System ... A DOS screen appears” in section 11, Troubleshooting to resolve this issue.

To turn off or shutdown tablet PC power, close the GBM-System program, and depress power button (A) briefly (1 second).

HARD POWER DOWN

NOTICE Use this procedure ONLY as a last resort. This shutdown method will take significantly longer (in excess of 5 minutes) to reboot since the Windows program performs a Disk Check.

If computer does not respond when: depressing the tablet buttons, using the digitizer pen, computer fails to shutdown or is frozen; depress power button (A) and hold for 7 to 10 seconds. Also, refer to section 11, Troubleshooting.

Gain- Exposure-Zoom-Direction-Pipe Count-Status Control

Adjust the Gain, Exposure, Zoom, Left/Right, Up/Down, Pipe Count and Status fields using either the Select Up or Select Down buttons (B) until desired field is highlighted.

To increase or decrease the values in the fields, use the Up or Down buttons (C).

- Gain control adjusts the camera sensitivity.
- Exposure control adjusts the amount of light available to the camera.
- Zoom control adjusts the camera zoom lens in and out.
- Left/Right control moves the image left or right on the screen.
- Up/Down control moves the image up or down.

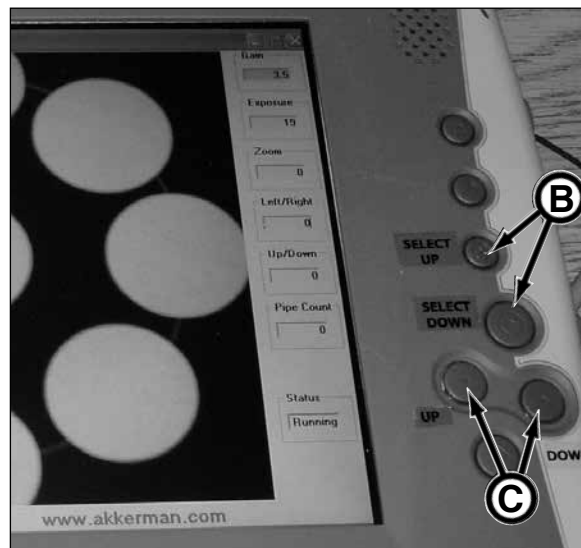
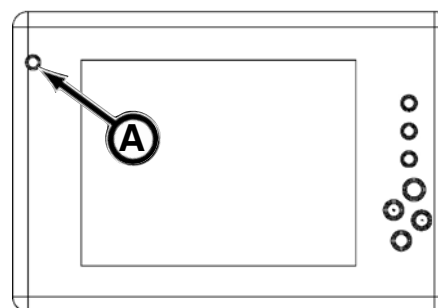

Screen Brightness Control

To increase screen brightness, hold down button (A) while depressing button (B) to desired brightness.

To decrease screen brightness, hold down button (A) while depressing button (C) to desired brightness.

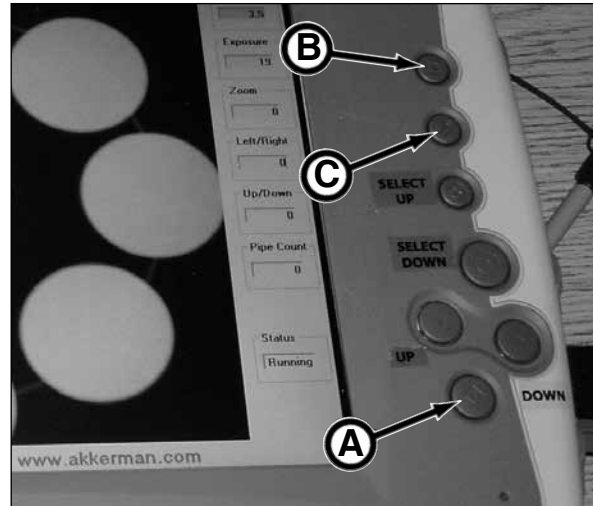

Using Digitizer Pen

When using pen, look on the pointer on the screen, not on the tip of the pen.

Use the pen for many of the same tasks you perform with a mouse:

1. *To select an item on the screen as you would with the left button of an external mouse:*
Tap the item with the tip of the pen.
2. *To double-click an item on the screen as you would with the left button of an external mouse:*
Tap the item twice with the tip of the pen. (You need to lift the pen from the tablet briefly and quickly between taps.)
3. *To select an item as you would with the right button of an external mouse:*
Press and hold down the pen button until a circle of red dots appear with a mouse icon, then lift the pen.

NOTICE

The pen must be held steady while performing the right click. Otherwise, the computer interprets that you are moving the mouse.

NOTICE

The button on the side of the pen does not function with the existing software configuration.

Accessing The Task Bar / Start Button

Access the task bar (D) at the bottom of the tablet screen to select start button, programs, control panel, etc.

With the digitizer pen at a 90 degree angle to the bottom of the tablet screen, hold pen for about one second and lift up pen to unhide the task bar.

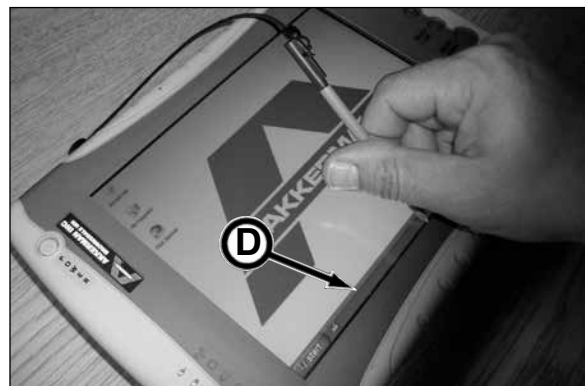

Entering Data

Data will be entered with the digitizer pen through the input panel. There are two ways to gain access to the input panel. Either click the Input Panel icon  on the task bar, or hover the digitizer pen over the character field in which data is to be entered, and click the input panel icon.

NOTICE When hovering over a character field, a pause before use will cause the input panel to disappear. Simply hover over the character field to reactivate the input panel.

There are three ways to enter data via the input panel. On the left are three icons which represent the input methods:



writing pad. Simply write or print desired data and press INSERT.



character pad. Write or print an individual character in the character slots and press INSERT.



onscreen keyboard. Click each desired letter on the keyboard using the pen and press INSERT.

Using the Theodolite Remote Focus

The remote focus feature (standard equipment as of SN FA42035F-87 and after, otherwise a remote focus kit is available for SN FA42035F-86 and before) allows the operator to focus the theodolite image on the Tablet PC screen at the controls of the Tablet PC docking station instead of making the necessary adjustments directly on the theodolite focus ring.

The remote focus assembly is equipped with a dual speed focus adjustment; SLOW or FAST. Flip the toggle switch (A) as follows:

SLOW - use for fine focusing.

FAST - use for close or distant focusing.

Other Control Buttons:

- Depress the IN button (B) for gradual adjustment during close focusing.
- Depress the OUT button (C) for gradual adjustment during distant focusing.
- Buttons can be toggled quickly for fine focus adjustment.

NOTICE (If equipped with Remote Focus Kit [SN FA42035F-86 & Before]) When the red LED LIMIT light (D) is illuminated, focus is at the end of travel and you must release button, and then reverse travel direction. Holding button with red LIMIT light illuminated could cause damage to motor and/or belt. The green LED RUN light (E) illuminates when the motor is running.

NOTICE (Tablet PC With Remote Focus [SN FA42035F-87 & After]) When the focus is at the end of travel, you will notice that there is no more focus adjustment or the belt will start slipping. Release travel button to prevent premature wear to motor or belt.

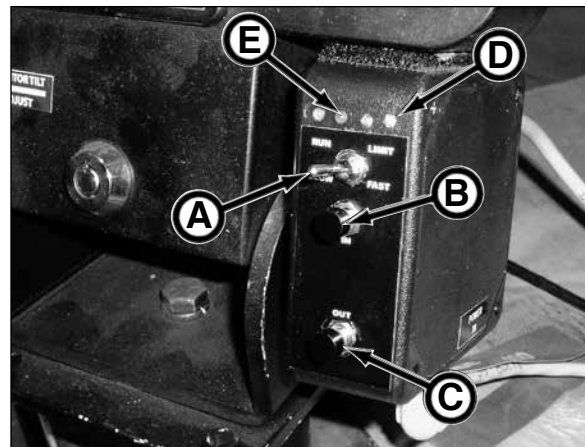

Remote Focus Control Kit (SN FA42035F-86 & Before)

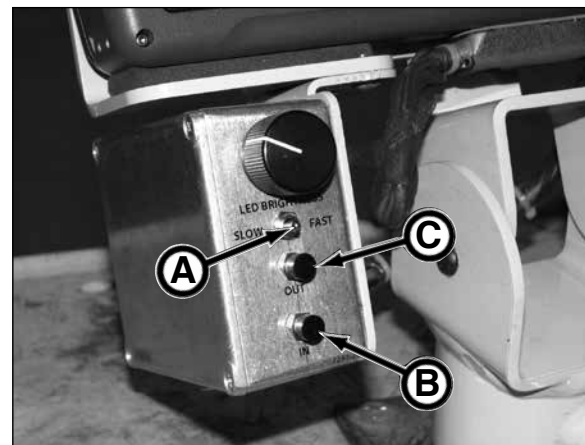

Remote Focus Control (SN FA42035F-87 & After)

NOTES

POWER PACK P275T CONTROLS

The P275T power pack provides hydraulic power for the jacking frame and tooling components. The six cylinder, 275 HP diesel engine drives triple load sensing, variable volume, and torque limiting piston pumps.

The hydraulic hoses are stored on hose reels for ease of routing hoses to jacking frame and Powered Cutter Head.

The hoses are connected to the GBM/PCH hydraulic connections as follows:

- A – Return Hose Connection
- B – Return Hose Connection
- C – Rotation/PCH Auger Drive Pressure Connection
- D – Rotation Load Sense Hose Connection
- E – Powered Cutter Drive Pressure Connection
- F – Powered Cutter Drive Load Sense Connection
- G – Case Drain Hose Connection
- H – Thrust Pressure Hose Connection
- I – Thrust Load Sense Connection
- J – Main Suction Valve
- K – Cooling Pump Suction Valve

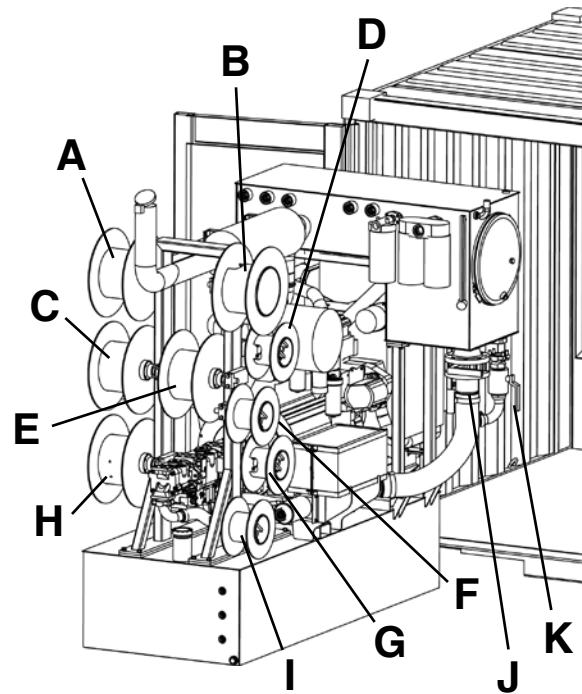

Hydraulic Pressure Gauges & Adjustment Valves

Use the pressure gauges to monitor the GBM jacking thrust (L), PCH cutter drive (M), and drive rotation/PCH rotation drive (N) pressures.

Jacking

Operating range in high pressure is up to 5,000 psi (34.474 MPa) with a maximum pressure of 6,000 psi (41.368 MPa).

PCH Cutter Drive

Operating range in high pressure is up to 4,000 psi (27.579 MPa) with a maximum pressure of 5,000 psi (34.474 MPa).

Drive Rotation/PCH Rotation Drive

Operating range in low pressure is up to 2,000 psi (13.789 MPa) with a maximum pressure of 2,500 psi (17.236 MPa).

Operating range in high pressure is up to 4,000 psi (27.579 MPa) with a maximum pressure of 5,000 psi (34.474 MPa).

The pressure adjustment valves are factory set as follows:

Jacking - 6,000 psi (41.368 MPa)

Set the Jacking Speed switch per pipe rating:
Slow - 200 ton, Fast - 100 ton

If your pipe has a lower thrust load pressure rating, use adjustment valve (O) to adjust the pressure to protect the product pipe. To adjust the pressure, refer Adjusting Jacking Pressure in Operation section.

PCH Cutter Drive - 5,000 psi (34.474 MPa)

The cutter drive adjustment valve (P) should **only** be adjusted per factory instructions.

Drive Rotation/PCH Rotation Drive - 5,000 psi (34.474 MPa) The rotation adjustment valve (Q) should not be adjusted.

(continued on next page)

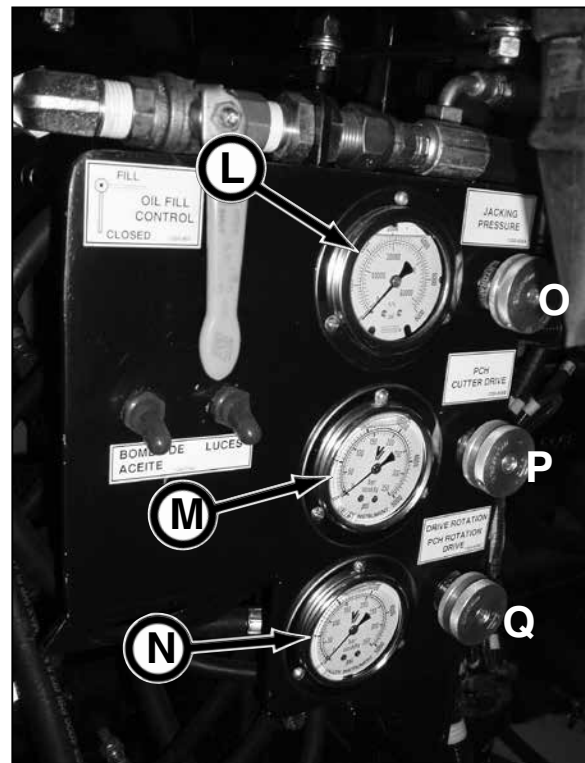

POWER PACK (continued)

Container Light Switch (A)

Oil Pump Switch (B)

Turn switch ON to pump hydraulic oil into the hydraulic reservoir.

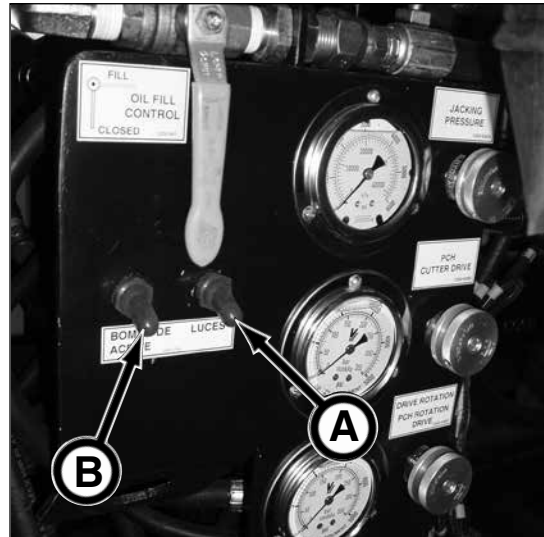

Hydraulic Return Filter Indicators (C)

To prevent under or over servicing of the hydraulic filter elements, filter indicators have been installed in your GBM Power Pack.

The green OK zone indicates that the filter is functioning properly. The yellow zone indicates that the filter will soon require replacement.

Replace return filter when the needle on the gauge is in the red CHANGE zone (see 10. Check Hydraulic Return Filter Indicators in Periodic Maintenance section).

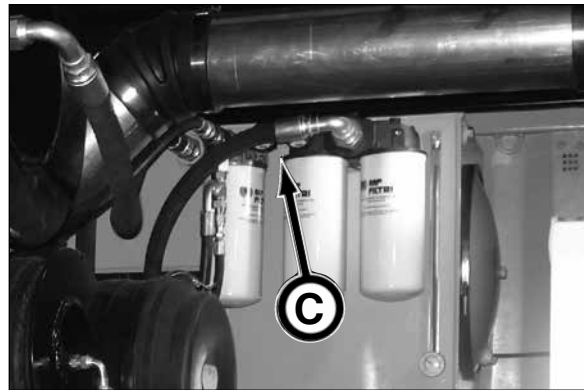

Emergency Stop

Push Emergency Stop button (D) IN to stop all electrical and hydraulic functions.

The button will light when it is pushed IN.

This button must be pulled out to restart engine.

NOTICE The emergency stop button must be pulled out and the main suction valve (E) must be fully open for engine to start.

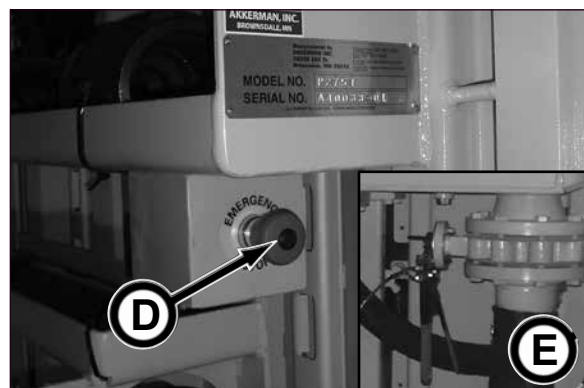

POWER PACK P150Q CONTROLS

The P150Q power pack provides hydraulic power for the jacking frame and tooling components. The four cylinder, 154 HP diesel engine drives triple load sensing, variable volume, and torque limiting piston pumps.

The hydraulic hoses are stored on hose reels for ease of routing hoses to jacking frame and Powered Cutter Head.

The hoses are connected to the GBM/PCH hydraulic connections as follows:

- A – Return Hose Connection
- B – Case Drain Hose Connection
- C – Powered Cutter Drive Pressure Connection
- D – Thrust (Jacking) Pressure Hose Connection
- E – Powered Cutter Drive Load Sense Connection
- F – Thrust (Jacking) Load Sense Connection
- G – Rotation/PCH Auger Drive Pressure Connection
- H – Rotation/PCH Auger Drive Load Sense Hose Connection

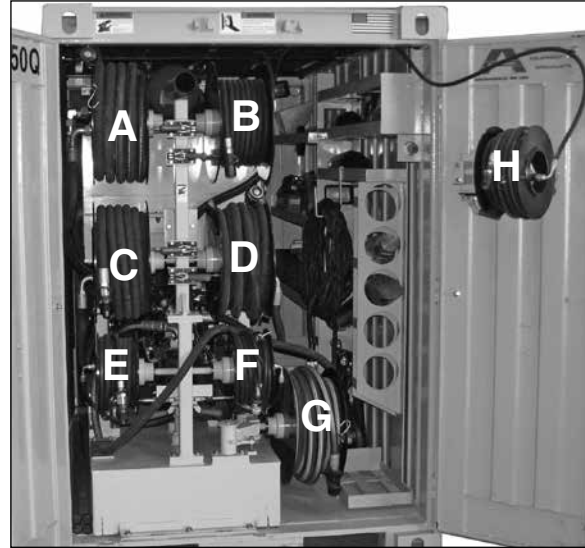

Hydraulic Pressure Gauges & Adjustment Valves

Use the pressure gauges to monitor the GBM jacking thrust, PCH cutter drive, and drive rotation/PCH auger drive pressures.

Jacking (I)

Operating range in high pressure is up to 5,000 psi (34.474 MPa) with a maximum pressure of 6,000 psi (41.368 MPa).

PCH Cutter Drive (J)

Operating range in high pressure is up to 4,000 psi (27.579 MPa) with a maximum pressure of 5,000 psi (34.474 MPa).

Drive Rotation/PCH Auger Rotation Drive (K)

Operating range in high pressure is up to 4,000 psi (27.579 MPa) with a maximum pressure of 5,000 psi (34.474 MPa).

The pressure adjustment valves are factory set as follows:

Jacking Valve (L) - 5,000 psi (34.474 MPa)

If your pipe has a lower thrust load pressure rating, use adjustment valve to adjust the pressure to protect the product pipe. To adjust the pressure, refer Adjusting Jacking Pressure in Operation section.

PCH Cutter Drive Valve (M) - 5,000 psi (34.474 MPa)

The cutter drive adjustment valve should **only** be adjusted per factory instructions.

Drive Rotation/PCH Auger Rotation Drive Valve (N)

- 5,000 psi (34.474 MPa)

The rotation adjustment valve should not be adjusted.

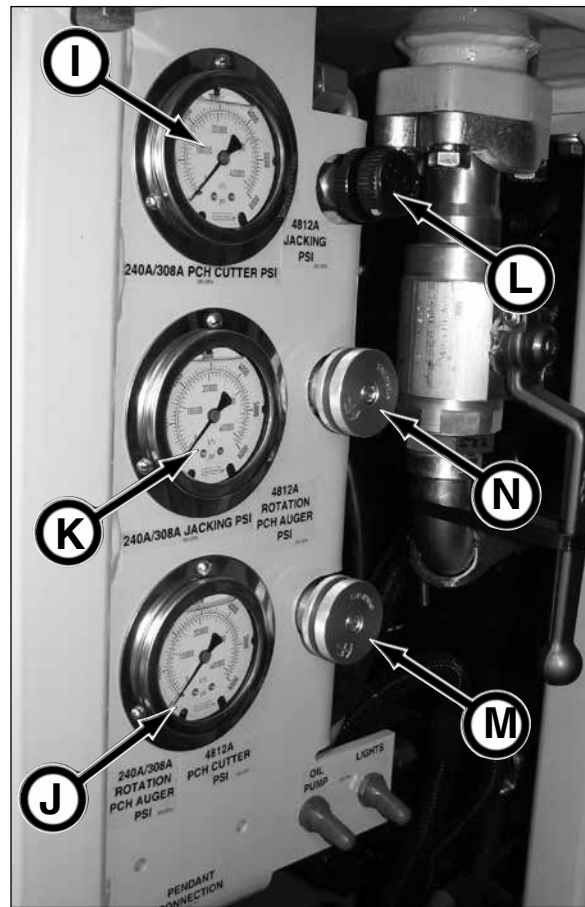

(continued on next page)

P150 POWER PACK (continued)

Container Light Switch (A)

Oil Pump Switch (B)

Turn switch ON to pump hydraulic oil into the hydraulic reservoir.

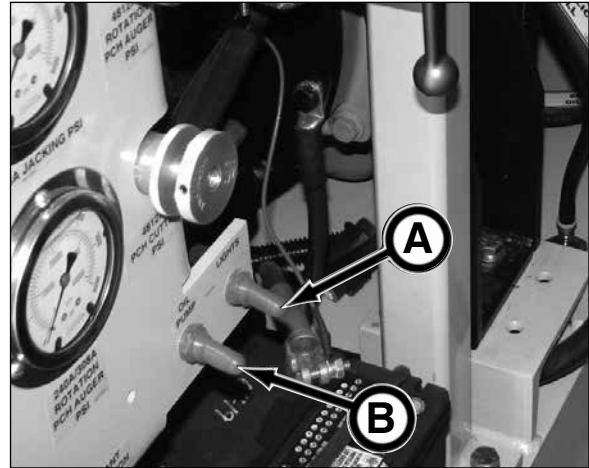

Hydraulic Return Filter Indicators (C)

To prevent under or over servicing of the hydraulic filter elements, filter indicators have been installed in your GBM Power Pack.

The green OK zone indicates that the filter is functioning properly. The yellow zone indicates that the filter will soon require replacement.

Replace return filter when the needle on the gauge is in the red CHANGE zone (see 10. Check Hydraulic Return Filter Indicators in Periodic Maintenance section).

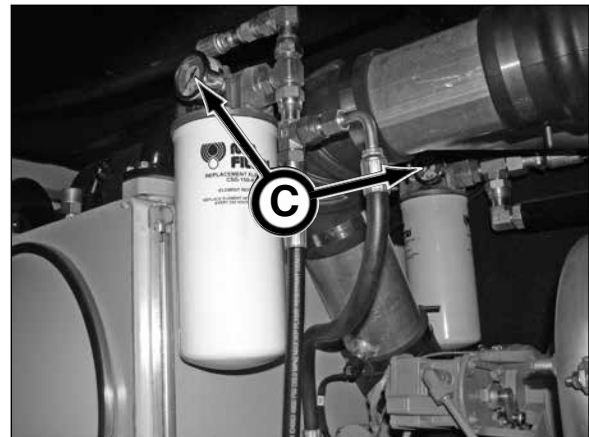

Emergency Stop

Push Emergency Stop button (D) IN to stop all electrical and hydraulic functions.

The button will light when it is pushed IN.

This button must be pulled out to restart engine.

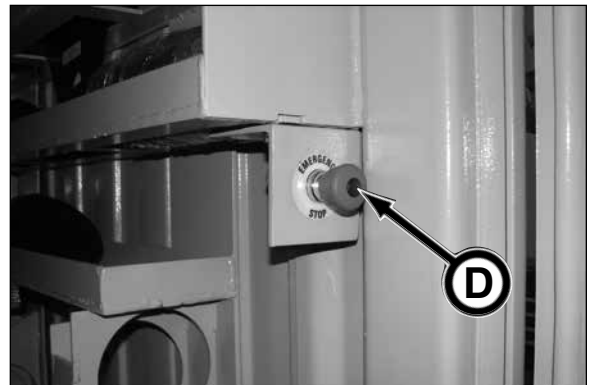

CONTROL PENDANT - P150Q & P275T**NOTICE**

Refer to the Deere engine manual for more information.

The control pendant allows the operator in the launch shaft to control the power pack and monitor vital engine functions.

Diagnostic Gauge/Hour Meter (A)

The diagnostic gauge (A) displays diagnostic trouble codes (DTCs) as they are accessed. Other information on the engine can be accessed using the touch keys. The hour meter feature displays the operating hours of the engine and should be used as a guide for scheduling periodic maintenance. If the diagnostic gauge receives a trouble code from an engine control unit, the current display will switch to a warning or shutdown screen that will display the trouble code number, the description of the code and the corrective action needed.

Tachometer (B)

The tachometer indicates engine speed in hundreds of revolutions per minute (rpm).

Engine Oil Pressure Gauge (C)

The oil pressure gauge indicates engine oil pressure as follows:

Full load rated speed is 50 ± 15 psi (345 ± 103 kPa).

Minimum rated speed is 40 psi (275 kPa).

Minimum at 800 rpm is 15 psi (105 kPa).

This unit is equipped with a low engine oil pressure safety switch. If the oil pressure is too low, the engine will automatically shut down to prevent engine damage.

Engine Coolant Temperature Gauge (D)

Normal engine coolant operating temperature range is 180° to 202°F (82° to 94°C). If coolant temperature rises above 234°F (112°C), reduce load on engine. Unless temperature drops quickly, stop engine and determine causes before resuming operation.

This unit is equipped with a engine high temperature safety switch. If the engine coolant temperature exceeds a set point, the engine will automatically shut down to prevent engine damage.

12V To Monitor & Control Panel Switch (E)

(P275 SN 1 - 4 Only) Flip switch UP to provide power to the tablet PC/control console or DOWN to shut down power to tablet PC/control console.

High-Low Speed Select Rocker Switch (F)

The high-low speed select switch (F) is used to set the engine operating speeds at slow (turtle) or fast (rabbit). Factory preset idle speeds can also be adjusted using bump speed enable switch (H) with speed select switch (G).

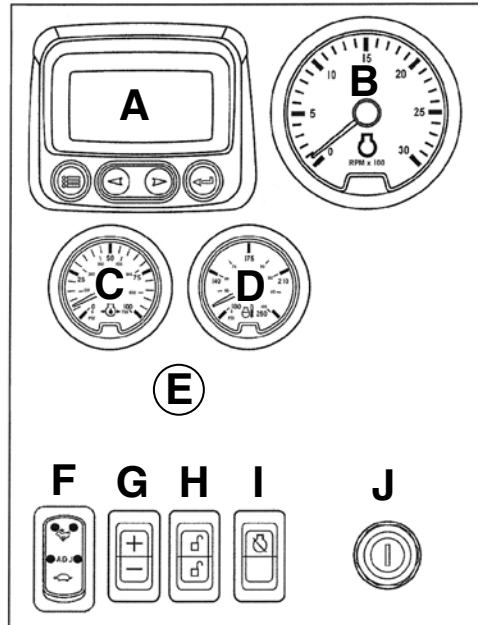
**Speed Select Switch (G)**

The speed select switch (G) is used to bump engine speed up (+) or down (-) in small increments during operation. This switch must be used with the bump speed enable switch (H) in the unlocked position (top or bottom half of button depressed).

Bump Speed Enable Switch (H)

This is a three-position switch (H) with the center position as OFF (locked). With this switch in the OFF position, the speed select switch (G) is also locked, to prevent accidental changes in operating speed. Pressing upper or lower half of switch (H) will unlock or enable the bump speed switch to take effect using speed select switch (G).

Override Shutdown Switch (I)

Switch will be present, but may not be active, depending on engine controller (ECU) options originally selected. If switch is active, pressing the upper half of the override shutdown switch (G) will override an engine shutdown signal. The switch must be pressed within 30 seconds to prevent undesired shutdown of engine. Pressing this switch will override the engine shutdown for 30 seconds at a time to move vehicle to a safe location.

Key Start Switch (J)

The three-position key start switch (J) controls the engine electrical system. When the key switch is turned clockwise to START, the engine will crank. When the engine starts, the key is released and returns to the ON (RUN) position.

Pre-Start Inspection

⚠ WARNING

Do not operate this equipment until you read, study, and understand this manual. A daily inspection of the equipment must be performed to prevent severe personal injury or death and equipment damage.

The contractor is fully responsible for the safety of all personnel on the job site. Check with the contractor that all site preparation requirements are in place. Be sure to comply with all OSHA regulations, such as: an active safety program is in practice, a confined space permit (if needed) is issued, personal protective equipment is being worn; flammable, combustible, and hazardous materials are properly stored; and a lockout/tagout procedure is in place.

Use the following checklist ✓ as a guide for your daily pre-start inspection.

	1. Use "ONE-CALL" notification to check for buried utility lines prior to tunneling.
	2. Check the excavated launch and reception pits or shafts for proper shoring or bracing to prevent slides or cave-ins.
	3. A qualified electrician must check that all electrical connections are properly secured and grounded prior to operation.
	4. Thoroughly clean equipment of mud and dirt.
	5. Check condition of personal protective equipment. Replace equipment if defective.
	6. Contractor is responsible for all personnel to wear proper protective equipment on the job site.
	7. Remove combustible or flammable materials from equipment. Store materials properly.
	8. Test air monitoring and ventilation detectors for proper operation.
	9. Inspect GBM equipment for damage. Repair or replace as needed.
	10. Be sure all covers and guards are in place before operation.
	11. Check for loose or missing hardware. Replace damaged or missing hardware.
	12. Check for worn, loose, or damaged wire. Repair or replace wiring.
	13. Tighten loose clamps or fittings.
	14. Check wire harnesses for frayed or worn insulation or wires. Replace damaged or worn harnesses.
	15. No riders are allowed on the GBM.
	16. Check for fluid leaks. Repair leak or replace components.
	17. Keep job site clean and organized.
	18. Check equipment for proper lubrication.
	19. Remove all personnel from inside the GBM.
	20. Check for leaks in hydraulic hoses and/or lines (replace defective hoses and/or lines).
	21. Check hydraulic hoses and lines for wear and/or damage. Replace any defective hoses and/or lines.
	22. Be sure all suction valves are open and valve handles tie strapped to prevent accidental closure.
	23. Remove all tools on GBM.
	24. Before operating, become aware of all pinch point areas on the GBM by conducting a visual inspection.

NOTES

Operation

HOW TO USE THIS SECTION

There are several components that are used with the Guided Boring Machine (GBM). Components vary depending upon your desired upsizing installation process; three step pipe installation, integral bearing swivel cutter head installation, powered cutter head pipe installation, and auger boring pipe installation. Refer to “GBM Installation Options” in this section.

This section is divided into nine subsections to help you identify the contents of this section. The subsections will also make it easier for you to go back to specific areas for reference.

6-5-1 Operation Guidelines

- 6-5-1 Operation Guidelines
- 6-5-2 GBM Installation Options

6-10-1 Shaft Set Up

- 6-10-1 Setting Up The Launch & Reception Shafts

6-15-1 GBM Frame Set Up In Shaft

- 6-15-1 Setting Up The GBM In Launch Shaft
- 6-15-6 GBM Frame Quick Coupler Installation

6-20-1 Power Pack Operation

- 6-20-1 Starting The Engine - P275T
- 6-20-3 Starting The Engine - P150Q
- 6-20-6 Stopping The Engine - Emergency Stop
- 6-20-7 Adjusting Thrust Pressure

6-25-1 Guidance System Set Up

- 6-25-1 Checking Theodolite Zero Point Calibration
- 6-25-6 Assembling The Guidance System
- 6-25-11 Preliminary Theodolite Set Up For Line & Grade
- 6-25-20 Tablet PC Start Up & Operation
- 6-25-28 Final Theodolite Set Up

6-30-1 Installing Pilot Tubes

- 6-30-1 Installing Steering Head Adapter To Steering Head
- 6-30-6 Installing Pilot Tubes
- 6-30-14 Log Of Progress

6-35-1 Installing Upsizing Tool

- 6-35-1 Three Step Method: Installing Auger Casing With Reaming Head
- 6-35-20 Upsizing Tool Lubrication From Reception Shaft
- 6-35-22 Installing Safety Chain Assembly/Casing Auger Pin To Auger & Casing
- 6-35-24 Installing 16” HD Integral Bearing Swivel Cutter Head
- 6-35-47 Using The Latching System
- 6-35-51 Using Powered Cutter Head
 - 6-35-51 Use Jetting & Pipe Lubrication
 - 6-35-54 Soil Stabilization (Chemical Delivery)
 - 6-35-55 Installing Powered Cutter Head - 20, 22.5 & 28.5
 - 6-35-55 Front Section
 - 6-35-68 Rear Section
 - 6-35-78 Installing Powered Cutter Head - 36 & 44
 - 6-35-78 Front Section
 - 6-35-88 Rear Section
 - 6-35-101 Removing Powered Cutter Head From Reception Shaft

6-40-1 Installing Product Pipe

- 6-40-1 Installing Product Pipe

6-45-1 Miscellaneous

- 6-45-1 Pilot Tube Pull Back Through Launch Shaft

Operation

NOTES

Operation - Operation Guidelines & Installation Options

OPERATING GUIDELINES

⚠WARNING Do not operate this equipment until you read, study, and understand this manual. Failure to do so, could result in severe personal injury or death.

1. Before operating, read and understand the Safety, Pre-Start Inspection, and Operation sections.
2. Do not operate this equipment while under the influence of alcohol, drugs, or medication.
3. Follow all Federal, State, and Local safety regulations and procedures.
4. Be sure OSHA prescribed safety personal protective equipment is being worn by all personnel.
5. Be sure the area is safe for operation. Keep work site clean and organized.
6. NEVER operate equipment if it has been engulfed with water. Contact your Akkerman Product Support representative for proper procedures on how to restore equipment for operation.
7. Have a fully charged fire extinguisher on the job site at all times.
8. Before operating, repair all equipment problems.
9. Be sure the excavated launch and reception shafts are properly shored or braced to prevent slides or cave-ins.
10. Test air monitoring and ventilation detectors for proper operation. Never enter a tunnel without gas detectors.
11. A fully trained and qualified signal person must direct the excavator or crane operator when lifting and lowering equipment into the launch or reception shafts.
12. Never walk or work under any part of the excavator or crane and suspended loads.
13. Remove plumb bobs from string lines and place in storage container after use. Never hang or secure plumb bobs over shaft. Doing so may cause severe injury or death from a falling plumb bob.
14. Operate jacking system at lowest pressure possible to prevent excessive heat build up.
15. Test all controls to make sure they work properly.
16. Pressure peaks cause hoses to jump without notice. Keep all personnel away from hoses during operation of equipment.
17. Lock out electrical power at the source (generator) before servicing electrical components.
18. Avoid pinch points. Keep hands away from moving parts. Watch your fingers, hands, and legs while equipment is in operation.
19. If this manual is lost, contact your Akkerman Product Support Representative for a new manual or download this manual from the Akkerman web site at www.akkerman.com.
20. High pressure hydraulics are used on the GBM. Be sure all covers and guards are in place before operating.
21. Check theodolite level often.
22. Check line and grade alignment on target monitor often to avoid misalignment. Keep pilot tube ventilated to prevent condensation buildup in tube which will result in poor target visibility.
23. Do not make any modifications to any Akkerman products. Doing so could cause structural failure and will void the warranty.
24. Do not make adjustments or repairs to the hydraulic system components while in operation or until all pressure is released and power pack is locked out, tagged out.
25. Be sure all suction valves are open and valve handles tie strapped to prevent accidental closure.

GBM PIPE INSTALLATION OPTIONS

1. Three Step Method for 11" to 16" OD (279 - 406 mm) Pipe

Step 1: PRECISE INSTALLATION OF PILOT TUBES

The first step is the installation of the pilot tube on line and grade.

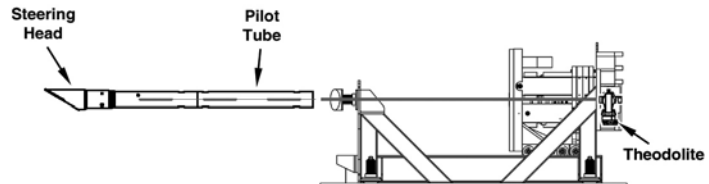

Step 2: ADVANCING THRUST CASINGS ALONG PILOT TUBE PATH

The second step is to follow the pilot tube with a reaming head, or other upsizing tool, and standard thrust casings.

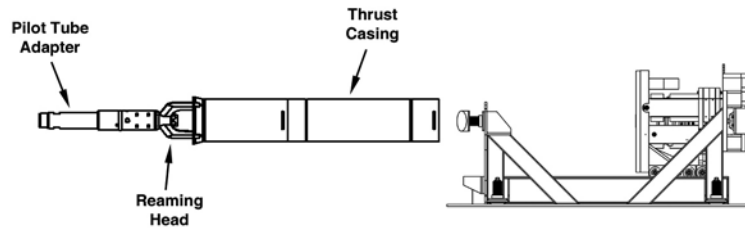

Step 3: INSTALLATION OF FINAL PRODUCT PIPE

In the third step, the final product pipe is installed behind the last section of the thrust casings.

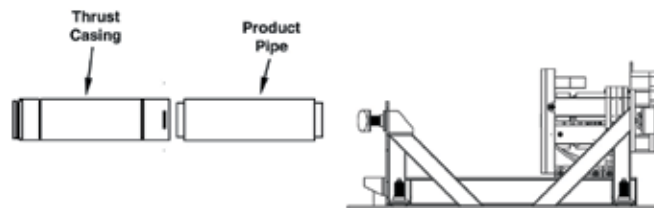

2. Three Step Method With Powered Cutter Head (PCH 20, 22.5, 28.5)
for 20" to 35.5" OD (508 - 902 mm) Pipe

Step 1: PRECISE INSTALLATION OF PILOT TUBES

The first step is the installation of the pilot tube on line and grade.

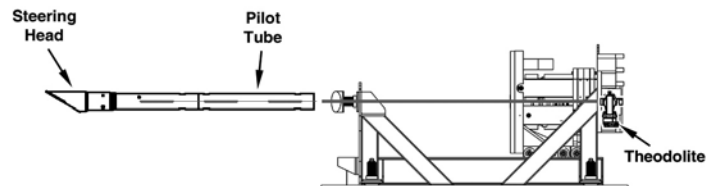

Step 2: ADVANCING THRUST CASINGS ALONG PILOT TUBE PATH

The second step is to follow the pilot tube with a reaming head, or other upsizing tool, and standard thrust casings.

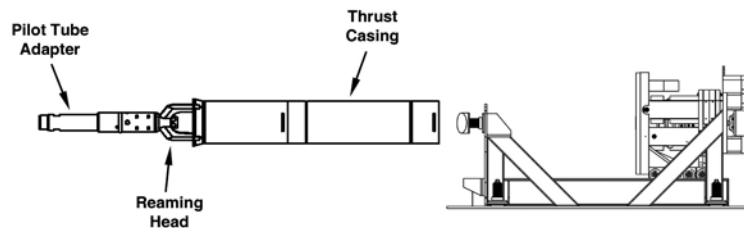

Step 3: INSTALLATION OF PRODUCT PIPE WITH POWERED CUTTER HEAD

In the third step, the powered cutter head follows the thrust casings to increase the bore to match the product pipe diameter.

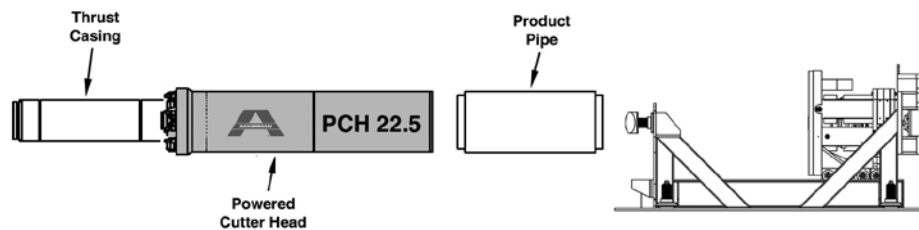

3. Three Step Method With Powered Cutter Head (PCH 36 & 44)
for 36" to 48" OD (914 - 1,219 mm) Pipe

Step 1: PRECISE INSTALLATION OF PILOT TUBES

The first step is the installation of the pilot tube on line and grade.

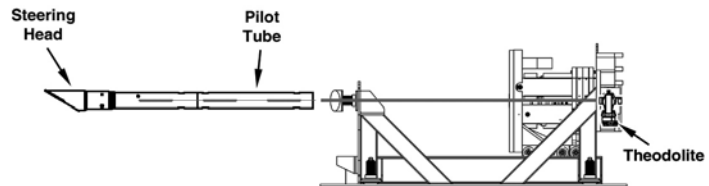

Step 2: ADVANCING THRUST CASINGS ALONG PILOT TUBE PATH

The second step is to follow the pilot tube with a reaming head, or other upsizing tool, and standard thrust casings.

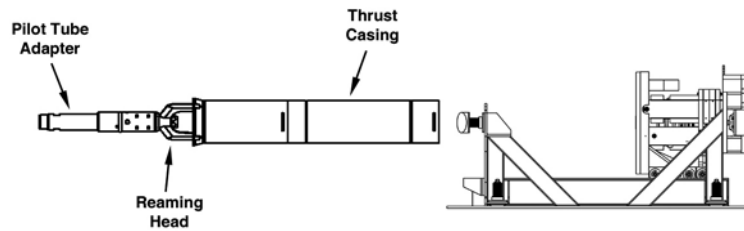

Step 3: INSTALLATION OF PRODUCT PIPE WITH POWERED CUTTER HEAD

In the third step, the powered cutter head follows the thrust casings to increase the bore to match the product pipe diameter.

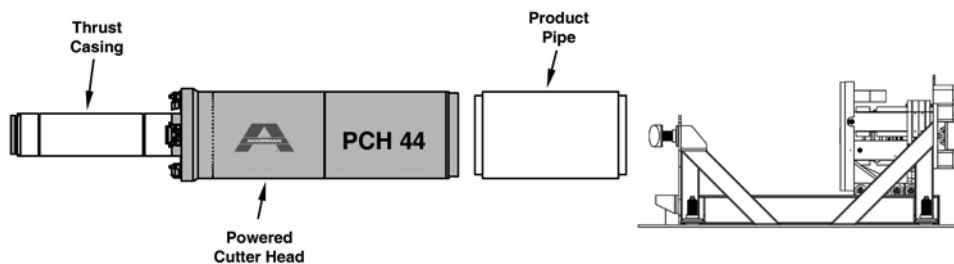

Operation - Shaft Set Up

SETTING UP THE LAUNCH AND RECEPTION SHAFTS

1. The contractor is fully responsible for the design and construction of the OSHA required launch and reception shafts. For setup and installation drawings specific to the project, pipe size and shoring type, contact the Akkerman Sales Department.

⚠ WARNING Gases may be present during excavation and could cause severe personal injury or death. Use an approved air analyzer to detect hazardous gases on the job site and in the tunnel at all times.

2. After the soil analysis, shaft layout design, and survey are complete, excavate the launch and reception shafts. Be sure the shafts will be well drained and use proper shoring or bracing in accordance with your local, state, and federal regulations.

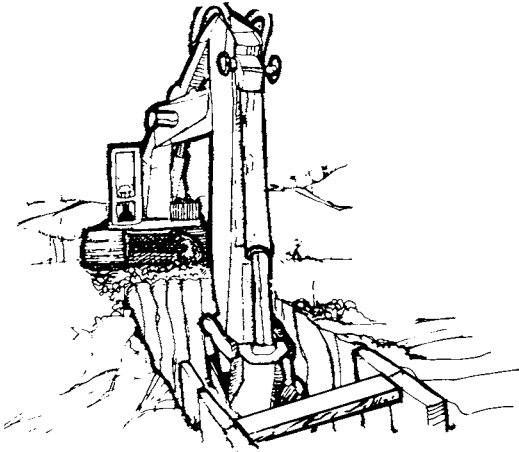

AEM is the original author and publisher of the above illustration

3. Construct a shaft floor with a solid base suitable for the weight of the jacking system and pipe. Typically a shaft uses 12 inches (305 mm) of stone for a dry shaft or a 6 inch (152 mm) or more concrete base for a moist shaft. Consult your civil and structural engineers for your shaft floor requirements.



4. If using stone for the shaft floor base, place road plates (1 inch [25.4 mm] plate of steel) or other solid material where the leveling assemblies will be located to prevent jacking assembly from shifting during operation.

5. Construct a backstop support (A) that will support 200 tons of thrust. A structural engineer must be consulted on the design of this support. This support must be square with the line of the pipeline.

If pullback may be used on the project, a front shaft section support (B) must be constructed to support 100 tons of force.

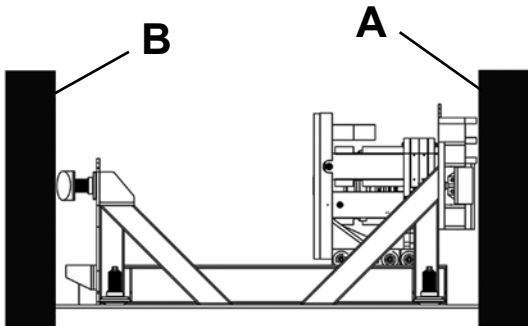

Operation

NOTES

Operation - GBM Frame Set Up In Shaft

SETTING UP THE GBM IN LAUNCH SHAFT

NOTICE

Before lowering GBM frame into shaft, the theodolite stand must be setup in shaft as follows in steps 1 through 9:

1. Install the guidance system mounting base at rear of launch shaft, centering the base on the centerline of the pipeline/flowline as indicated by surveying marks. Be sure to allow enough room so the guidance system does not touch any GBM frame member or shaft wall.
2. Using the mounting base as a guide, drive the four rods through the base and into the ground until they are in solid material. The base must have at least a 3" (76 mm) clearance on the bottom side of the plate so the theodolite stand can be mounted.

NOTICE

The rods must be positioned so the rods or the mounting plate do not contact any moving parts.

3. Level the base from front to back and side to side.

4. With the base level, secure the base to the rods with four set screws.

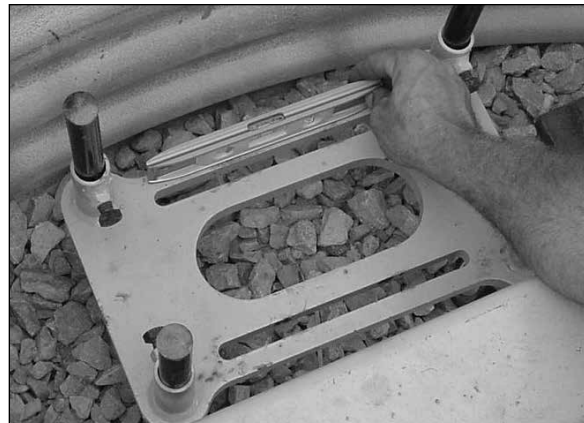
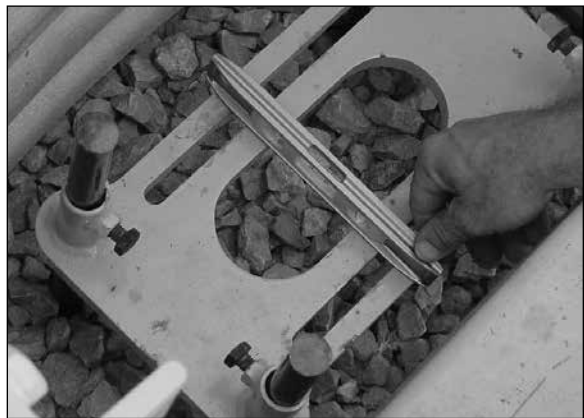

(continued on next page)

5. Center mounting plate on mounting base and secure with four 1/2 x 1-1/2 in. bolts.



6. Attach elevator column to mounting plate. Hand tighten only.

NOTICE If using full leg extension on GBM frame, you may need to either install an extension prior to the elevator column or use longer mounting rods to achieve proper theodolite height.



7. Insert elevator adapter/lateral slide assembly into column and secure with locking knob on column.



(continued on next page)

ROUGH CENTER ALIGNMENT

8. With the string line positioned to the surveying marks, suspend a plumb bob from the string line slightly above the theodolite. Move the theodolite base as needed until the theodolite center station point (A) is centered with plumb bob to establish the rough center alignment. You will have to use the lateral slide adjustment for fine tuning the center point, later in the preliminary theodolite setup.

9. Remove theodolite from stand.

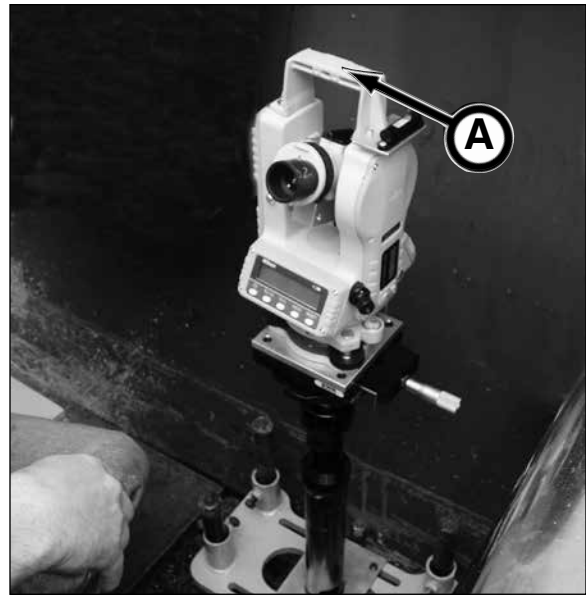

⚠ WARNING Suspended loads may fall and cause severe personal injury or death. If a hydraulic hose breaks from the boom of a crane/excavator, or load support fails, the boom or load can fall instantly. Do not walk or stand under a load.

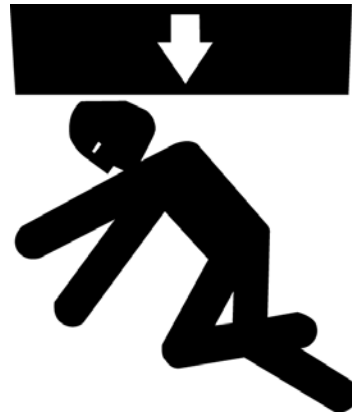

10. With the theodolite removed, carefully lower GBM frame into position in launch shaft. Use a properly rated four leg sling (20,000 lb. [9,072 kg] minimum).



(continued on next page)

11. Start leveling and setting line, elevation, and grade of the GBM frame to the centerline of the pipeline/flowline based on surveying marks. Be sure to compensate for the steering head overcut (1/2" [13 mm]) and the other upsizing tool overcut. Use alignment adapter guide on drive swivel assembly for centerline of jacking frame.

NOTICE

When using a PCH to maintain flowline, the machine must be set at an elevation of 1" above centerline. This will compensate for the 1/2" overcut when installing casings and augers and the 3/4" overcut for the PCH installation.

NOTICE

Use a transit or string line to transfer the surveyor's marks to the shaft for setting the jacking frame on line.

NOTICE

When setting up GBM frame in the shaft, keep in mind that the frame MUST be in the same line and grade as the product pipe.

NOTICE

It may be helpful to refer to Understanding Grade Degrees Versus Grade Percent in section 12, Specifications during this setup.

12. Install operator side (A) and center (B) platforms as shown.
- Mount plate support arms (C) on GBM with pins (D).
 - Lower platforms (A) on support arms (C).
 - Move support arms to desired location and secure with four 3/4 x 2 in bolts and washers (E).
 - Secure center platform (B) to make up tool bracket.

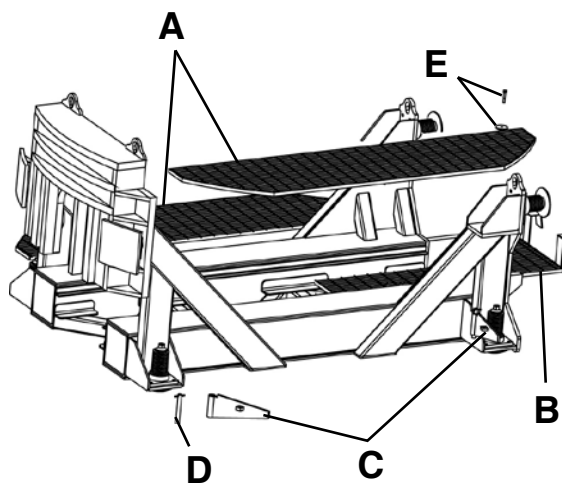

13. Secure GBM frame to shaft wall and/or floor as needed to prevent the frame from moving while jacking by tightening the front anchor blocks (F) against shaft wall or other braces. Periodically retighten the anchor blocks during operation.

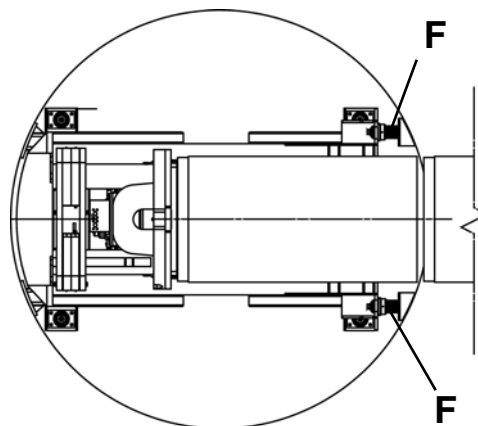

14. Position the Power Pack on firm, level ground at the top of the launch shaft.

⚠WARNING

Do not position the GBM Power Pack near the edge of the shaft where the ground may be unstable and cause a slide or cave-in. Doing so could cause severe injury or death.

(continued on next page)



15. Slide the vertical exhaust pipe extension (A) onto exhaust pipe and secure with clamp. Be sure the pipe extension is mounted in the vertical position as shown.

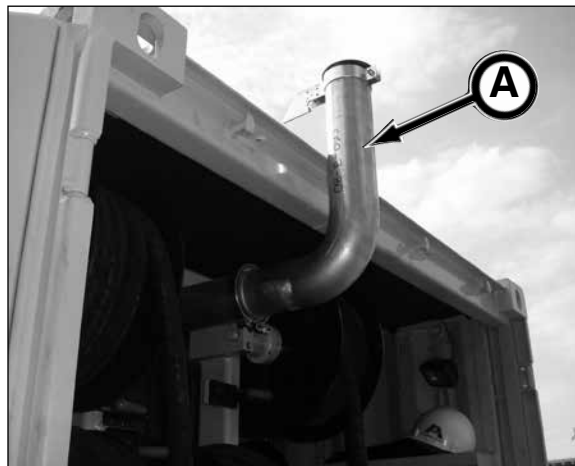

16. With the power pack engine shut down, roll out the hydraulic hoses and connect the hoses to the GBM jacking frame hydraulic connections as shown: rotation load sense (B), jacking load sense (C), case drain (D), P275T pressure IN drive rotation pressure (E), jacking pressure (F), tank return (G) and P150Q pressure IN drive rotation pressure (H). Refer to GBM Frame Quick Coupler Installation in this section.

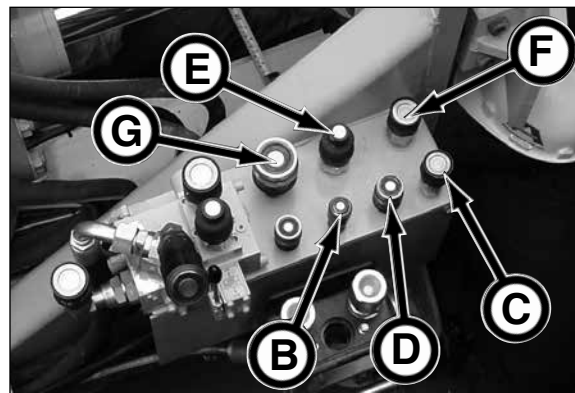

SN 1 - 3

17. Start the engine (refer to Start The Engine in this section, subsection Power Pack Operation).
18. Check the hydraulic system for proper operation and that there are no leaks at the quick couplers.
19. Once the GBM and Power Pack are properly set up, proceed to Guidance System Setup in this section.

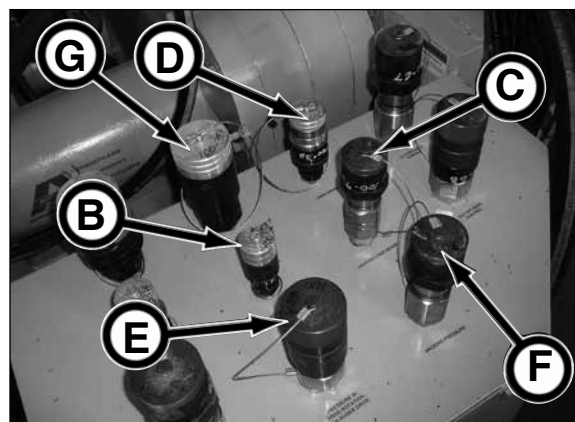

SN 4

- A - Exhaust Pipe Extension*
- B - Rotation Load Sense*
- C - Jacking Load Sense*
- D - Case Drain*
- E - Drive Rotation Pressure IN (P275T)*
- F - Jacking Pressure*
- G - Tank Return*
- H - Drive Rotation Pressure IN (P150Q)*

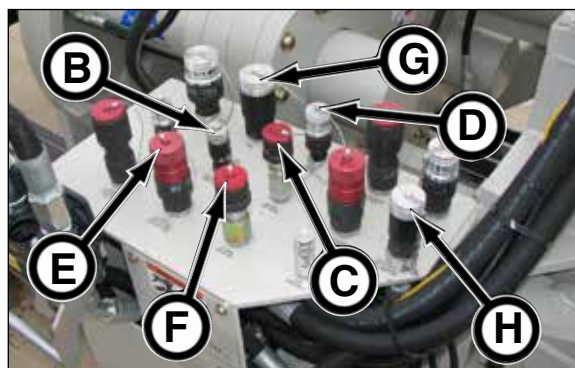

SN 5 & After

GBM FRAME QUICK COUPLER INSTALLATION

There are three types of connectors on the GBM frame. Use the following instructions to properly install the couplers. BEFORE installation, be sure to clean ALL mating surfaces to prevent contamination.

1. FASTER Quick Couplers

The Faster quick couplers are the case drain, rotation load sense, cutter load sense, and two tank quick coupler connections.

NOTICE If coupler is not fully locked, valve assembly damage will occur.

CONNECT

- a. Rotate main sleeve (A) clockwise (CW) until locking collar (B) snaps against fitting end (C).
- b. Check the locking mechanism, by rotating the main sleeve counterclockwise (CCW). If sleeve rotates, then the locking collar is not properly locked.

DISCONNECT

- c. Pull locking cover back and rotate main sleeve counterclockwise (CCW) until hose is removed.

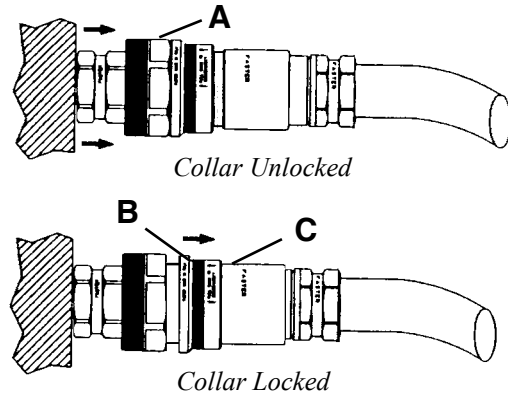

2. PERFECTING Quick Couplers

The Perfecting quick couplers are the jacking load sense, jacking pressure, drive rotation/PCH auger drive, cutter head pressure IN and two cutter head control quick coupler connections.

NOTICE NEVER clamp on the coupler sleeve. This will cause distortion, resulting in coupler damage.

CONNECT

- a. Hand tighten coupler by rotating clockwise (CW) until o-ring is no longer visible. If o-ring is visible, the connection is not locked.

DISCONNECT

- b. Rotate hose coupler counterclockwise (CCW) until hose is removed.

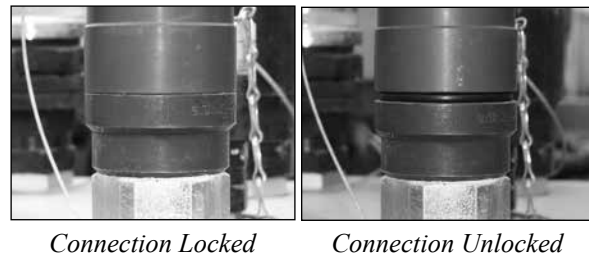

3. MULTIFASTER Quick Couplers

The Multifaster quick connection are the two PCH auger drive connections.

- a. Flip up port dust cover, push red release button (D) IN while rotating handle UP (E) to release quick-disconnect.

- b. Place male quick-disconnect (F) into position on female quick-disconnect block, and then rotate handle DOWN (G) until release button (D) pops out. Quick-disconnect is now locked into place.

- c. When installing next pipe or when removing casing and auger in reception shaft, release disconnect to disable the cutter head functions. Failure to do so could result in serious injury from contact with rotating auger.

- d. Reconnect male quick-disconnect after it has been communicated that you can proceed with advancement. The male quick-disconnect MUST be locked into place before cutter head will operate.

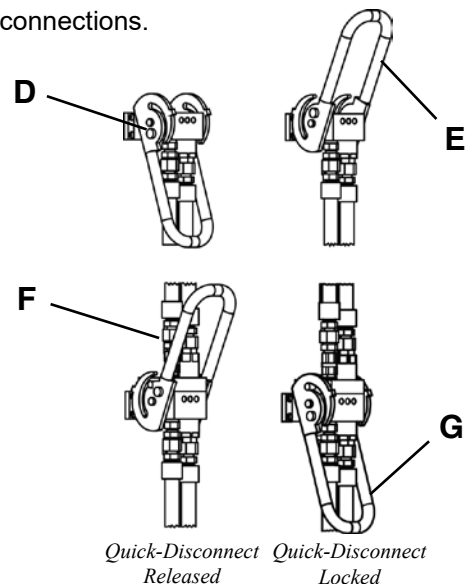

Operation - Power Pack Operation

STARTING THE ENGINE - P275T

NOTICE Refer to your John Deere engine Operator's Manual for detailed information on the proper break-in/cold weather starting and operation of your engine.

NOTICE (P275T SN 1 & 2 Only) The container doors **MUST** be open while engine is running to allow for proper engine ventilation. Running engine with doors closed **WILL** cause equipment damage.

1. Perform the daily maintenance items listed in section 9, Periodic Maintenance.
2. Clean hose connections prior to connecting hoses.
3. Connect hydraulic hoses from the power pack to the GBM connections **BEFORE** starting engine. Refer to step 4 below to install hoses to quick couplers.

NOTICE All hoses must be securely connected. If not equipment will be damaged.

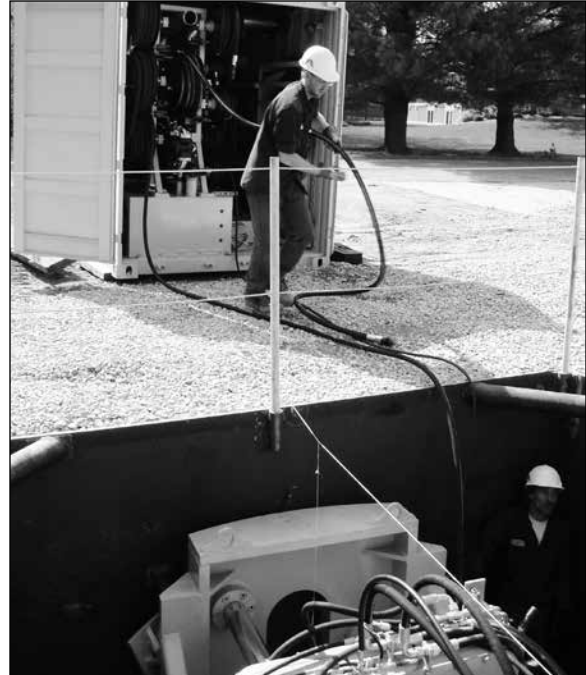

GBM Hydraulic Connections

4. GBM Frame Quick Coupler Connections

NOTICE If coupler is not fully locked, valve assembly damage will occur.

CONNECT

a. Rotate main sleeve (A) clockwise (CW) until locking collar (B) snaps against fitting end (C).

b. Check the locking mechanism, by rotating the main sleeve counterclockwise (CCW). If sleeve rotates, then the locking collar is not properly locked.

DISCONNECT

c. Pull locking cover back and rotate main sleeve counterclockwise (CCW) until hose is removed.

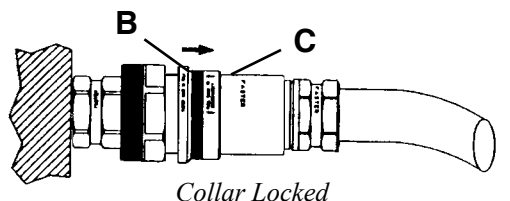
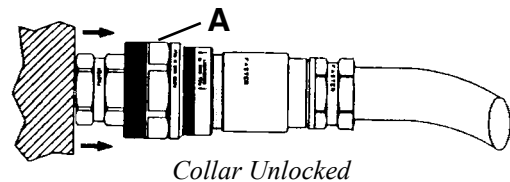

5. Check engine oil level. Add oil as needed.

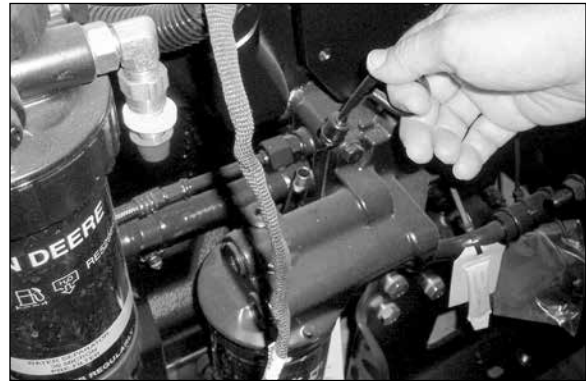

6. Connect power pack engine pendant cable to control pendant port (A).

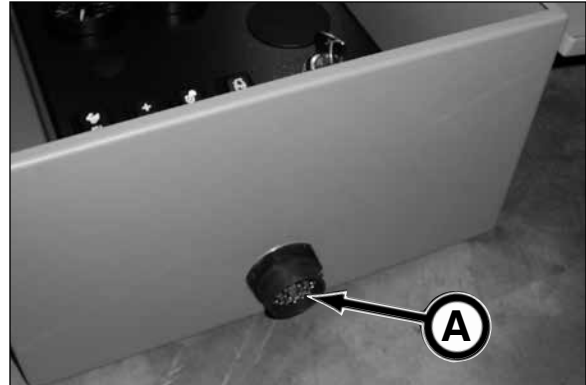

7. Check to be sure the main suction valve (B) is fully open. Engine will start only when main suction valve is the fully open position and the emergency stop button pulled out.

NOTICE BEFORE starting engine, be sure the cooling pump suction valve (C) is fully open, the valve handle is tie strapped to prevent accidental closure, and the Emergency Stop button is pulled out.

8. Set slow idle by pressing lower half (turtle) of high-low speed select switch (D).

NOTICE Do not operate starter for more than 30 seconds at a time. Doing so may cause the starter to overheat.

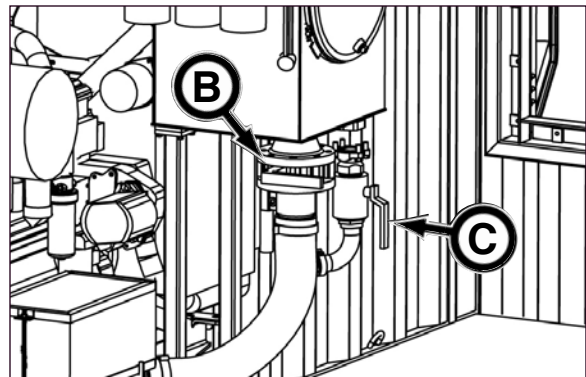

9. Turn the key switch (E) clockwise to the ON position. Once the indicator lights (F) turn off, turn the key switch clockwise to the START position to crank the engine. When the engine starts, release the key so it returns to the ON position.

10. As soon as the engine starts, check oil pressure gauge (G).

If gauge needle does not rise above minimum oil pressure specification of 105 kPa (1.05 bar) (15 psi) within 5 seconds, stop the engine and determine the cause. Normal engine oil pressure should be 345 kPa ± 103 (3.45 ± 1.03 bar) (50 ± 15 psi) at rated full load speed (1800 - 2500 rpm) with oil at normal operating temperature of 115°C (240°F).

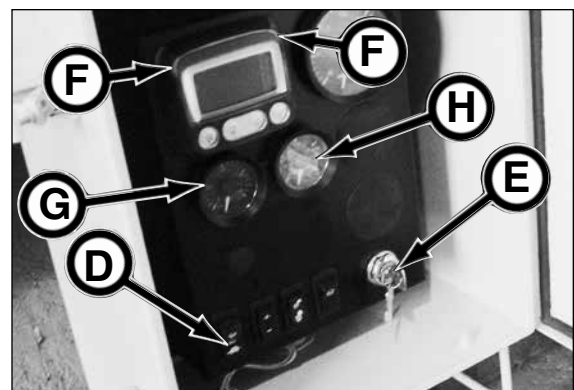

11. After engine starts, idle engine at no more than 1200 rpm until warm.

12. Watch coolant temperature gauge (H). Do not place engine under full load until it is properly warmed up. The normal engine coolant temperature range is 82° - 94°C (180° - 202°F).

13. Check all gauges for normal engine operation and run engine at full RPM while using the GBM unless otherwise noted. If operation is not normal (refer to your John Deere engine Operator's Manual), stop the engine and determine the cause.

- A - Pendant Port
- B - Main Suction Valve
- C - Cooling Pump Suction Valve
- D - Speed Select Switch
- E - Key Switch
- F - Indicator Lights
- G - Oil Pressure Gauge
- H - Coolant Temperature Gauge

STARTING THE ENGINE - P150Q

NOTICE Refer to your engine Operator's Manual for detailed information on the proper break-in/cold weather starting and operation of your engine.

NOTICE While engine is running, three container doors MUST be open and one door closed (as shown) for proper engine ventilation. Failure to do so WILL cause engine damage.

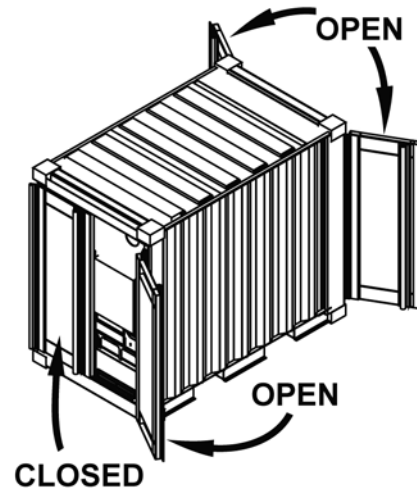

1. Perform the daily maintenance items listed in section 9, Periodic Maintenance.
2. Clean hose connections prior to connecting hoses.



P150Q Power Pack Hydraulic Hoses

3. Connect hydraulic hoses from the power pack to the GBM frame connections BEFORE starting engine. Refer to step 4 below to install hoses to quick couplers.

NOTICE All hoses must be securely connected. If not equipment will be damaged.



GBM Hydraulic Connections

(continued on next page)

Starting The Engine - P150Q (continued)

4. Quick Coupler Connection

NOTICE If coupler is not fully locked, valve assembly damage will occur.

CONNECT

a. Rotate main sleeve (A) clockwise (CW) until locking collar (B) snaps against fitting end (C).

b. Check the locking mechanism, by rotating the main sleeve counterclockwise (CCW). If sleeve rotates, then the locking collar is not properly locked.

DISCONNECT

c. Pull locking cover back and rotate main sleeve counterclockwise (CCW) until hose is removed.

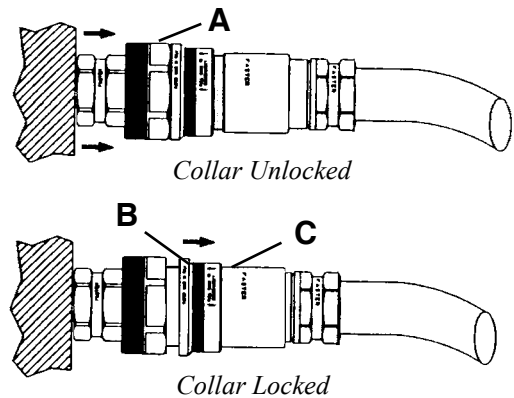

5. Check engine oil level. Add oil as necessary.

NOTICE BEFORE starting engine, be sure the thrust, rotation, and oil cooler suction valves are fully open and the valve handles tie strapped to prevent accidental closure and the Emergency Stop button is pulled out.



6. Connect power pack engine pendant cable to control pendant port (D).

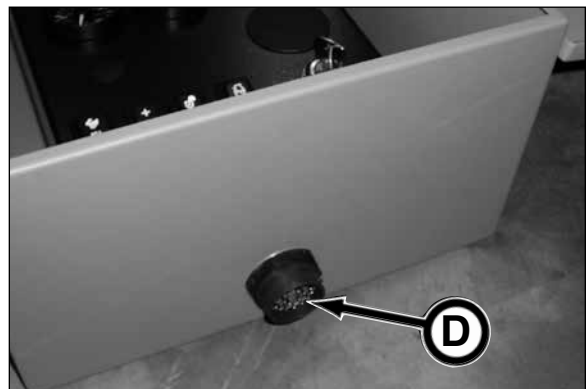

7. Set slow idle by pressing lower half (turtle) of high-low speed select switch (E).

NOTICE Do not operate starter for more than 30 seconds at a time. Doing so may cause the starter to overheat.

8. Turn the key switch (F) clockwise to the ON position. Once the indicator lights (G) turn off, turn the key switch clockwise to the START position to crank the engine. When the engine starts, release the key so it returns to the ON position.

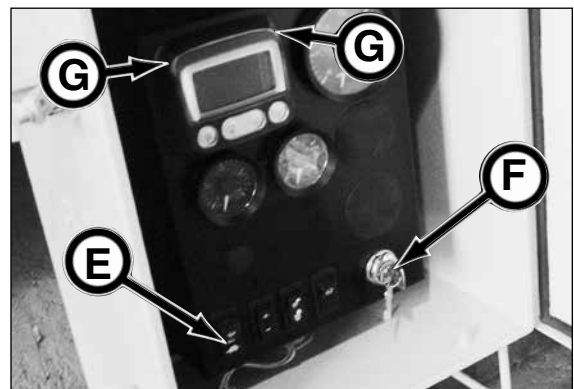

(continued on next page)

Starting The Engine - P150Q (continued)

9. As soon as the engine starts, check oil pressure gauge (A).

If gauge needle does not rise above minimum oil pressure specification of 105 kPa (1.05 bar) (15 psi) within 5 seconds, stop the engine and determine the cause. Normal engine oil pressure should be 345 kPa \pm 103 (3.45 \pm 1.03 bar) (50 \pm 15 psi) at rated full load speed (1800 - 2400 rpm) with oil at normal operating temperature of 115°C (240°F).

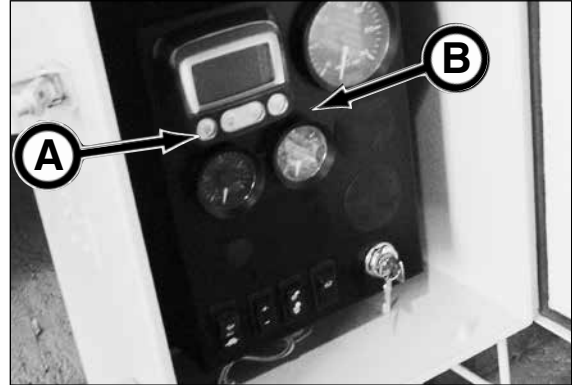

10. After engine starts, idle engine at no more than 1200 rpm until warm.
11. Watch coolant temperature gauge (B). Do not place engine under full load until it is properly warmed up. The normal engine coolant temperature range is 82° - 94°C (180° - 202°F).
12. Check all gauges for normal engine operation while using the GBM. If operation is not normal (refer to your engine Operator's Manual), stop the engine and determine the cause.

STOPPING THE ENGINE

NOTICE Before stopping an engine that has been operating at high engine speed, idle engine at least 2 minutes to cool hot engine parts.

1. Run engine at 1000-1200 rpm for at least 2 minutes to cool.
2. Flip the high-low speed select switch (A) down to low idle.
3. Turn key switch (B) counterclockwise to the OFF position to stop the engine.
4. Remove ignition key.

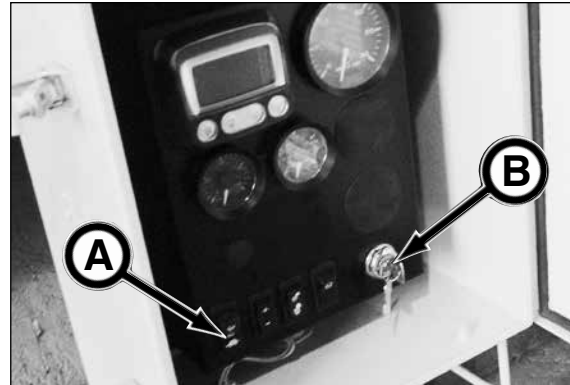

EMERGENCY STOP (E-STOP)

Push Emergency Stop button (C) IN to stop all electrical and hydraulic functions.

The button will light when it is pushed IN.

This button must be pulled out to restart engine.

NOTICE (P275T) The emergency stop button must be pulled out **and** the main suction valve must be fully open for engine to start.

NOTICE (P150Q) The emergency stop button must be pulled out for engine to start.

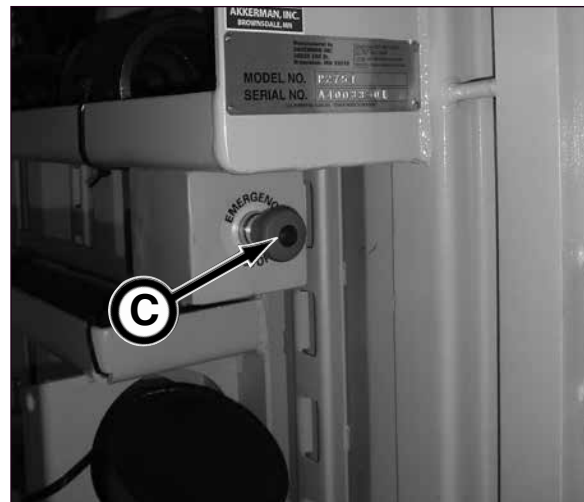

P275T Power Pack

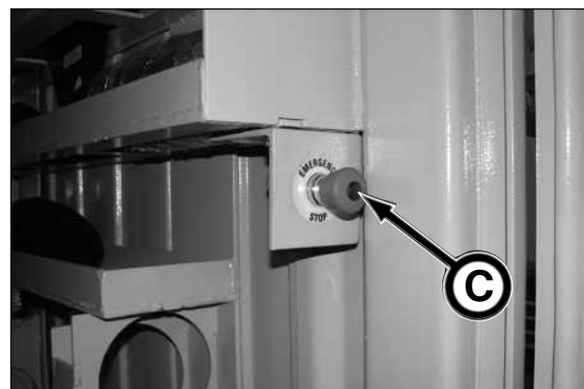

P150Q Power Pack

ADJUSTING THRUST PRESSURE

NOTICE

To protect your product pipe, you must be sure the product pipe rating can withstand the thrust pressure of the GBM. Since the P275T and P150Q Power Packs are capable of 6,000 psi (200 ton), and if your pipe is rated lower than 200 ton, the GBM thrust pressure **MUST** be readjusted. Failure to do so **WILL** break the pipe.

1. Check the thrust pressure rating for your product pipe.

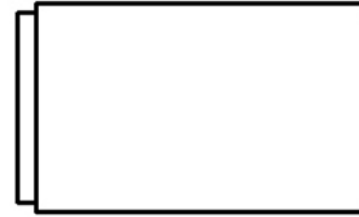

2. Calculate the pressure limit for your product pipe based on every 1000 psi is equal to 33.3 tons (in low speed) of thrust pressure. Or refer to the thrust pressure chart (to the right or the decal on the GBM).

psi Pressure	Tons Low Speed	Tons High Speed
500	16.7	8.3
1000	33.3	16.7
1500	50.0	25.0
2000	66.7	33.3
2500	83.3	41.7
3000	100.0	50.0
3500	116.7	58.3
4000	133.3	66.7
4500	150.0	75.0
5000	166.7	83.3
5500	183.3	91.7
6000	200.0	100.0

3. With the power pack hydraulic hoses connected to the GBM and the power pack engine running at full RPM, fully retract the GBM jacking cylinders by using the thrust cylinder control (A).
4. Check the thrust pressure on the drilling system pressure gauge (B) on the GBM or power pack. Operating pressure is checked by retracting the jacking cylinders and hold lever after the cylinder base has stopped moving. Observe pressure on gauge.

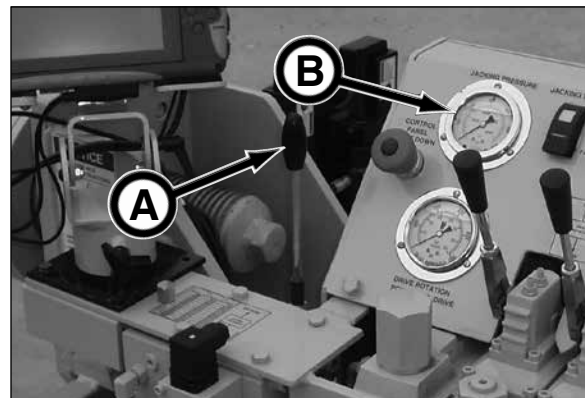

SN 1 - 3

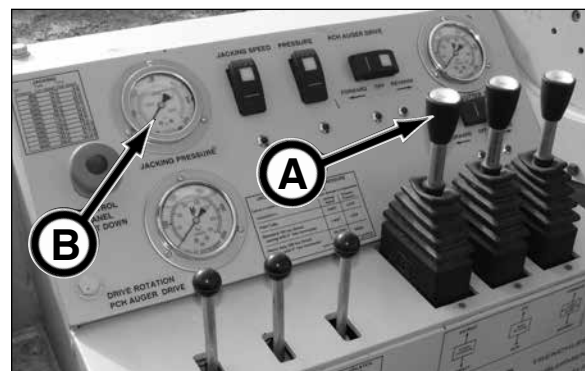

SN 4 & After

(continued on next page)

NOTICE Only a qualified service technician is allowed to perform pressure adjustments to the power pack.

If the pressure needs to be decreased, loosen lock collar (A) and turn adjustment dial (B) OUT. Once the pressure is properly adjusted, tighten lock collar.

If the pressure needs to be increased, loosen lock collar (A) and turn adjustment dial (B) IN. Once the pressure is properly adjusted, tighten lock collar.

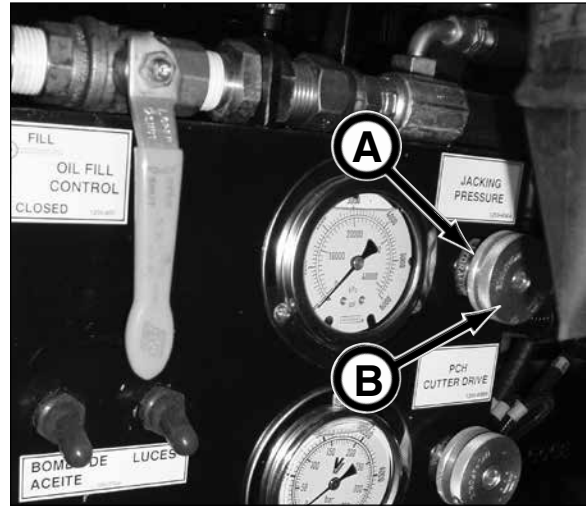

P275T Power Pack

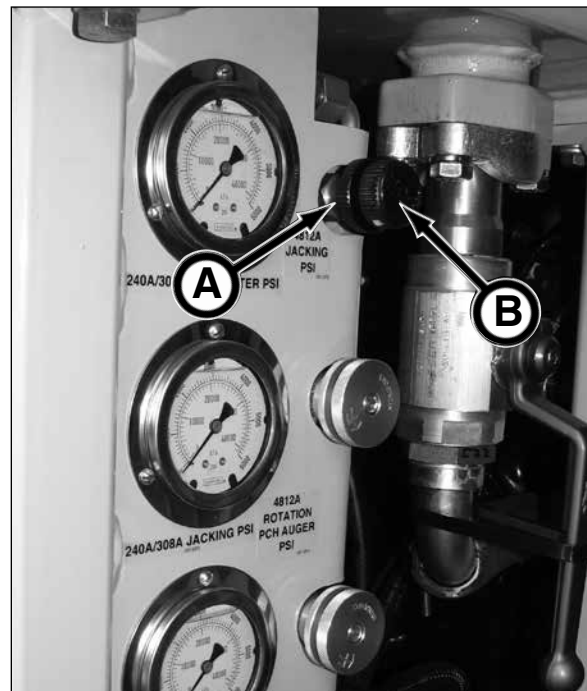

P150Q Power Pack

Operation - Guidance System Setup

CHECKING THEODOLITE ZERO POINT CALIBRATION

IMPORTANT: It is critical to check the zero point calibration of the theodolite before use. If the theodolite gets bumped, jarred, or dropped, the calibration must be checked. Failure to check this calibration could cause misalignment in your line and grade. Keep in mind, if the theodolite is misaligned one degree, you will be off nearly two ft (0.6 m) per 100 ft (30.5 m) in the drive.

1. Remove the 40X eyepiece with barrel and install the 30X eyepiece (included) to telescope.
2. Move telescope to the horizontal position and lock position with vertical lock knob.

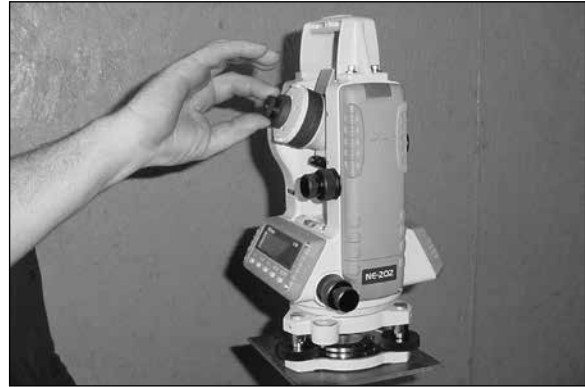

3. Level the theodolite with the circular level (A) using the leveling screws.

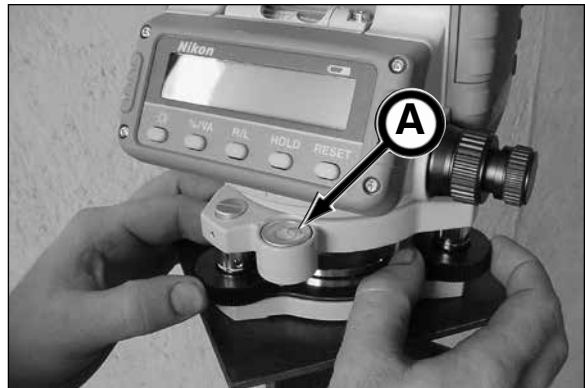

4. Using the plate level (B), level the theodolite using the leveling screws.



(continued on next page)

- Once theodolite is level, rotate theodolite 90° and level the theodolite with the plate level (A) using the leveling screws.

NOTICE

It is easier to level theodolite in step 5 if you use the same two leveling screws that were used in step 4.

- Repeat steps 4 and 5 until theodolite is level in both directions.

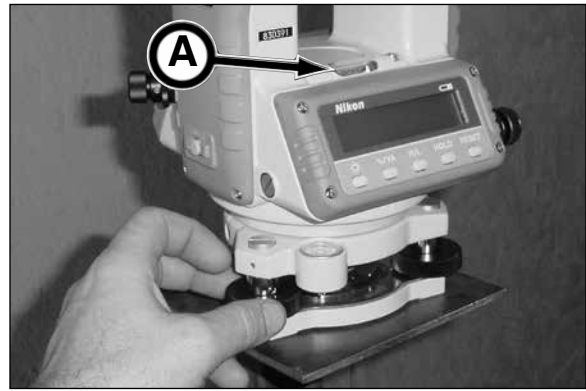

- Once theodolite is level, rotate theodolite 180° and check plate level (B) to ensure the theodolite is completely level.

If theodolite is not level, proceed to step 8.

If theodolite is level, proceed to step 10.

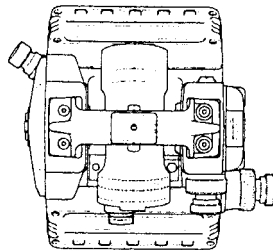

Theodolite Leveled In Step 7

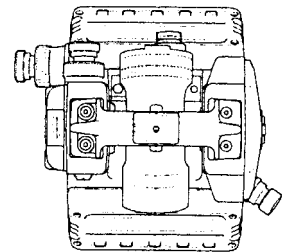

Theodolite Rotated 180° To Check Level In Step 8

- If level is off, insert adjustment tool (included with theodolite) into adjustment nut, and move the bubble half the distance that the bubble was off.



(continued on next page)

9. Relevel theodolite (repeat steps 3 through 7).

10. Turn ON theodolite.



11. "TILT TELESCOPE" is shown on the theodolite LED display. While holding telescope, loosen vertical adjustment/lock, then use the vertical fine adjust until the vertical alignment on the display reads, VA: 90° 00' 00".



12. Looking through the telescope, locate a stationary object approximately as long as your drive.



NOTICE

You will need to use the telescope focusing ring (A), to focus on the object. You may also need to adjust the lens so the cross hairs are well defined while viewing (as shown).

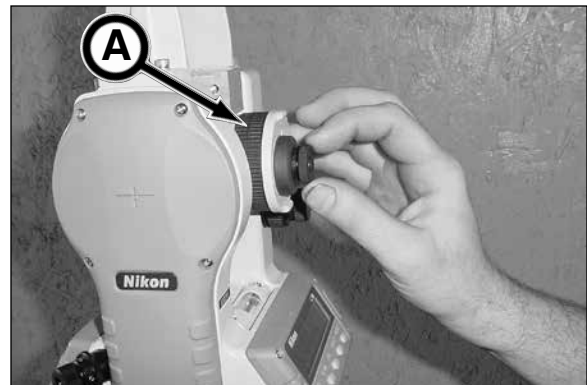

(continued on next page)

IMPORTANT! DO NOT USE THE HOLD BUTTON WITH THE GBM SYSTEM! Doing so will freeze the displayed horizontal angle readout which will remain unchanged regardless of theodolite directional movement.

13. Once the stationary object is positioned in the cross hairs, press the RESET button. The LED display will read HA: 00° 00' 00".

This will zero only your horizontal alignment.
This does not affect the vertical alignment.



14. Loosen the vertical adjust/lock and rotate the telescope 180°, and loosen the horizontal adjust/lock and rotate the theodolite base 180°.

NOTICE Take note of the vertical alignment reading on the LED display before rotating theodolite. After rotating 180°, these two readings should equal 360°. The horizontal reading should also equal 360°.



15. Using the horizontal fine adjust, turn knob until the horizontal alignment reads HA: 180° 00' 00".



16. Look into the telescope. The stationary object should be within the cross hairs.
17. If the stationary object is not within the cross hairs, the theodolite is out of adjustment and must be recalibrated. Refer to the Nikon Theodolite Instruction Manual, "Vertical Circle Zero Point Error."

(continued on next page)



18. Remove the 30X eyepiece from telescope.
19. Replace the 40X eyepiece with barrel as follows:



- a. While holding 40X eyepiece (A) by the knurled section, unscrew barrel section (B) counterclockwise (CCW) from eyepiece until finger tight, so focus is fully extended (the knurled section of eyepiece must not be against the barrel section).

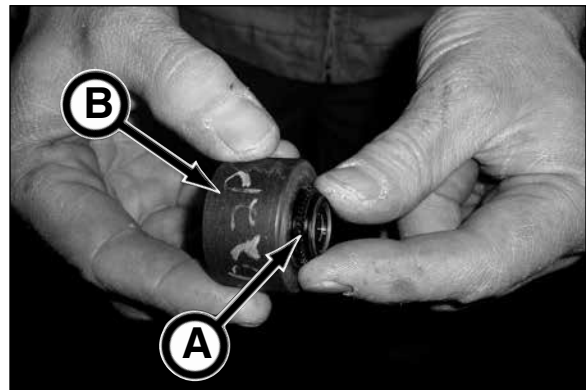

- b. Screw eye piece/barrel assembly into theodolite until resistance is felt, then turn an additional 3/4 turn. Do not bottom out barrel to prevent overtightening. If you feel you have overtightened, repeat steps 19a and 19b.

NOTICE DO NOT OVERTIGHTEN.
Overtightening will cause eyepiece focus failure.



20. Carefully place theodolite in storage case. Secure case.



ASSEMBLING THE GUIDANCE SYSTEM

NOTICE

The installation of the mounting base and elevator column is installed before lowering the 4812A frame into the shaft. Refer to Setting Up The GBM in Launch Shaft in this section, subsection GBM Frame Set Up In Shaft for installation of these components.

IMPORTANT: It is critical to check the zero point calibration of the theodolite before use. If the theodolite gets bumped, jarred, or dropped, the calibration must be checked. Failure to check this calibration could cause misalignment in your line and grade. Keep in mind, if the theodolite is misaligned one degree, you will be off nearly two feet per 100 feet in the drive. See Checking Theodolite Zero Point Calibration in this section.

⚠ WARNING

BEFORE setting up theodolite or performing maintenance in the rear of the 4812A frame, the cylinder stop (A) MUST be placed on cylinder rod. Failure to do so may result in serious personal injury or death.

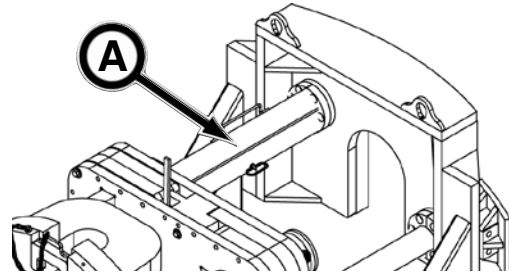

1. Attach theodolite to lateral slide by rotating theodolite base clockwise (CW) on lateral slide until snug. Do not overtighten.



2. Remove battery cover.

NOTICE

Check theodolite battery power before setting up for each drive. The battery power is shown on the theodolite display panel.



3. Separate cover from battery holder.
4. Install six new AA batteries into battery holder.



(continued on next page)

5. Secure battery holder into cover and replace cover.

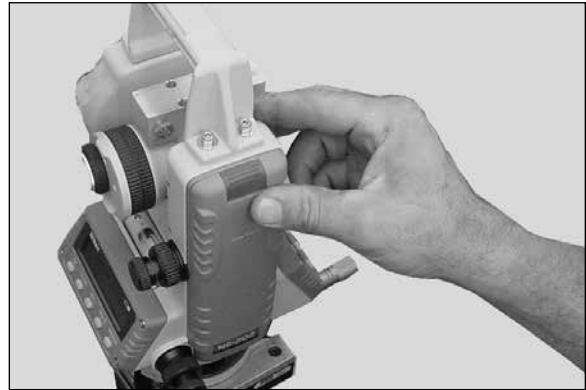

6. Level theodolite with the adjustment knobs located on the theodolite base.



7. Rotate theodolite 90 degrees and adjust until level.
8. Repeat steps 6 and 7 until theodolite is level in both directions.

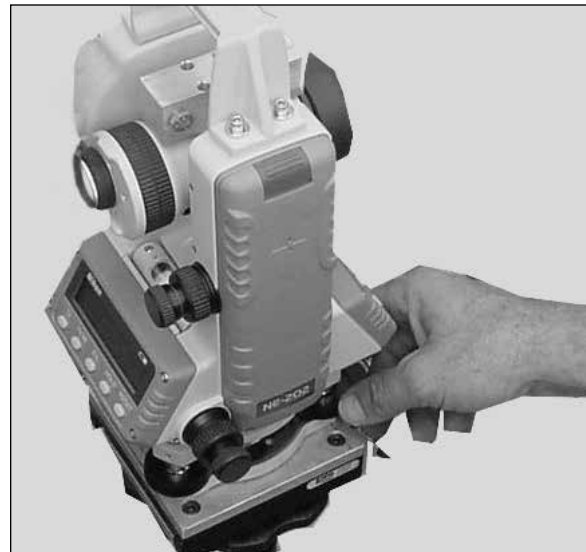

9. Remove bolts from mounting on telescope with lens in vertical position.



(continued on next page)

10. Install camera to theodolite with bolts removed in step 9. Tighten with 7/16 in. wrench.

NOTICE Place bolts on camera bracket before positioning bracket against theodolite.

NOTICE Be sure vertical lock is not set on theodolite.

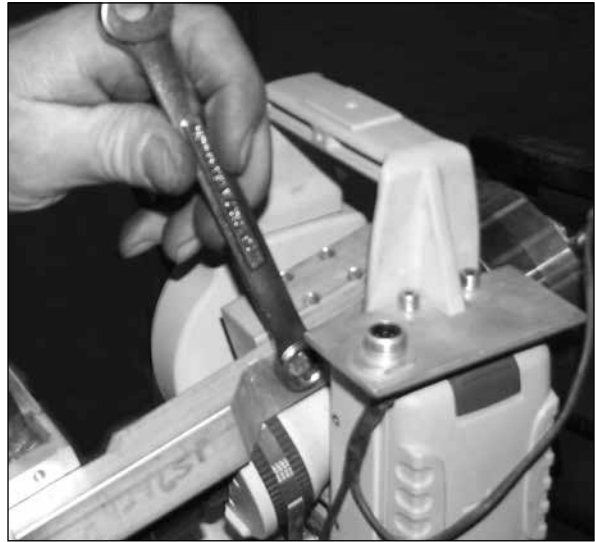

11. Remove telescope lens cap.

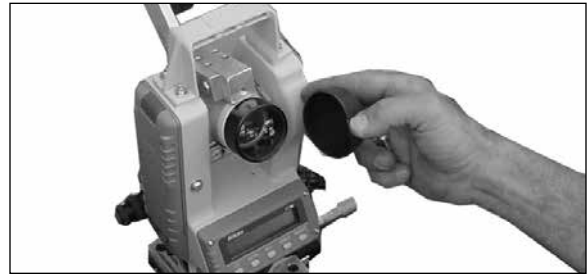

12. Attach counterweight to telescope and secure with one 1/4 x 2 in. screw.

13. Secure LED light cable to counterweight.

NOTICE The tip of the light must be directed into the telescope lens for the theodolite cross hairs to display on the monitor.

NOTICE BEFORE powering up guidance system and power pack, refer to Tablet PC Start Up & Operation - Checking Guidance System Camera Connections in this section.



14. Secure camera cables in two places so as not to affect the calibration of the theodolite.

15. Install tablet PC onto GBM frame mount.



(continued on next page)

16. Mount power adapter to tablet PC docking station.



17. If not already attached, connect power cord (A) from power pack to control pendant.

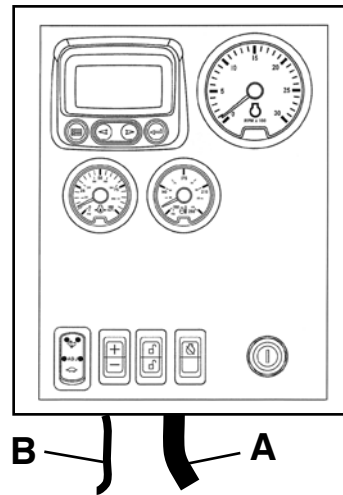

18. Connect power cable (B) to control pendant connection and the other end of the cable to the Power IN connection on the tablet PC assembly control box (as shown).



SN FA42035F-86 & Before)

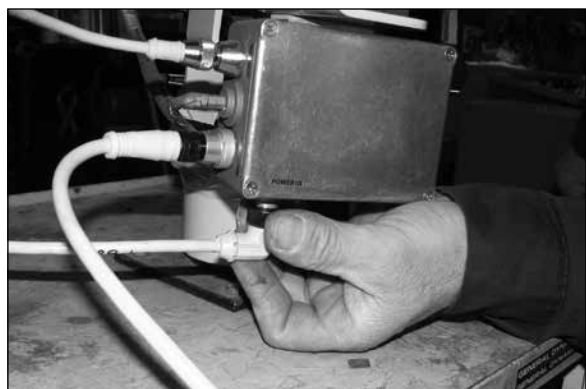

SN FA42035F-87 & After)

(continued on next page)

19. (SN FA42035F-86 & Before) Connect LED light cable to LED Cable connection on the tablet PC assembly control box.



20. (SN FA42035F-86 & Before) Connect camera cord (hard wired) from tablet PC assembly control box to camera connection.



21. (SN FA42035F-87 & After) Connect LED light and remote focus cable to LED/Focus cable connection on the tablet PC assembly control box.

22. (SN FA42035F-87 & After) Connect other end of the LED/Focus cable to the LED/Focus cable connection on the theodolite.



23. (SN FA42035F-87 & After) Connect camera cable to Camera connection on tablet PC assembly control box.



24. (SN FA42035F-87 & After) Connect other end of the camera cable from the tablet PC assembly control box to the camera connection on camera bracket.

25. Proceed to Preliminary Theodolite Setup For Line & Grade in this section.

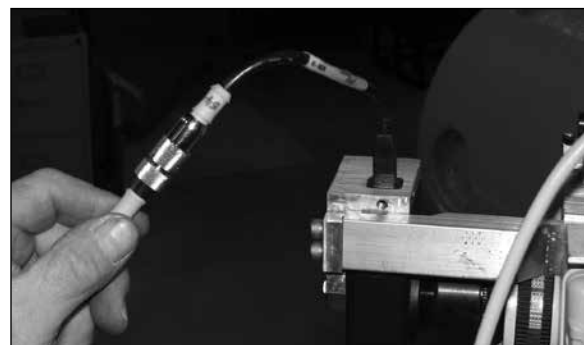

PRELIMINARY THEODOLITE SETUP FOR LINE & GRADE

⚠ WARNING BEFORE setting up theodolite or performing maintenance in the rear of the 4812A frame, the cylinder stop (A) MUST be placed on cylinder rod and the power pack must be shut down. Failure to do so may result in serious personal injury or death.

Latching the frame forward will provide more work room while setting up the theodolite.

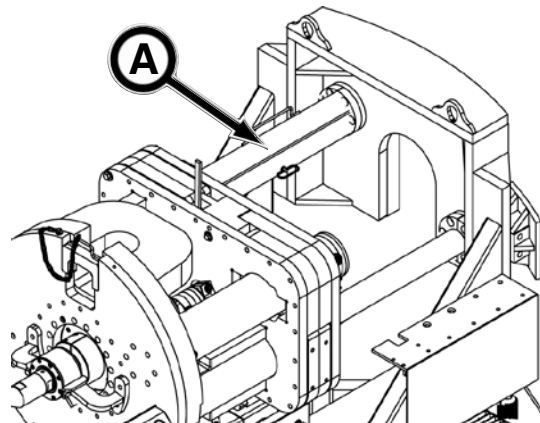

⚠ WARNING Falling plumb bob can cause serious personal injury or death, and/or equipment damage.

NEVER hang or secure the plumb bob overhead when not in use.

ALWAYS remove the plumb bob from the string lines and place in storage container after use.

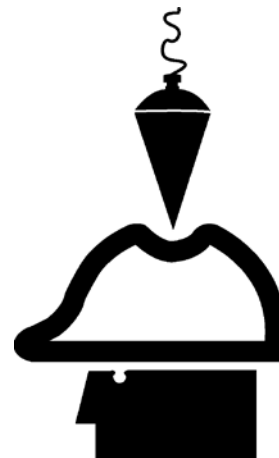

1a. Using the surveying marks on edge of shaft, run a string line between these two marks to set the line of the theodolite. Then use two lines and plumb bobs to transfer the surveying marks to the shaft floor.

NOTICE For best monitor viewing, use white string to transfer the surveying marks.



(continued on next page)

- b. Position one line and plumb bob a minimum of 28 inches (711 mm) in front of the theodolite.

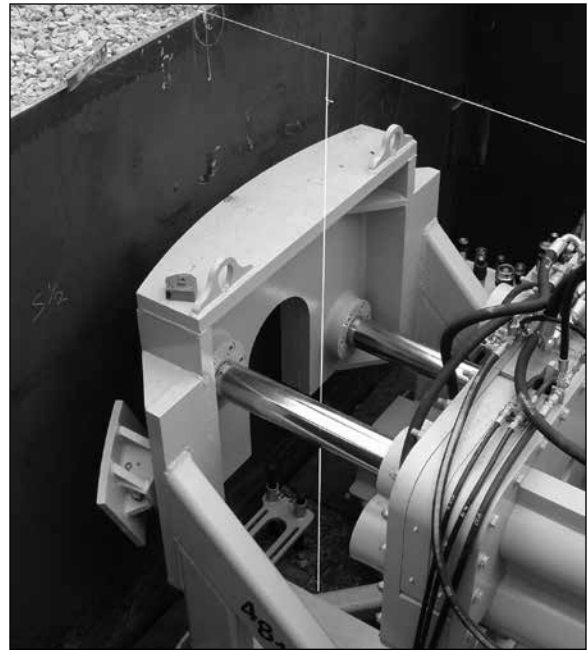

- c. Position a second line and plumb bob at the front end of the jacking frame as far forward as possible. Suspend plumb bob into cup of oil.

NOTICE Be sure plumb bob is free to move in oil. Do not allow the plumb bob to touch the bottom or sides of cup.

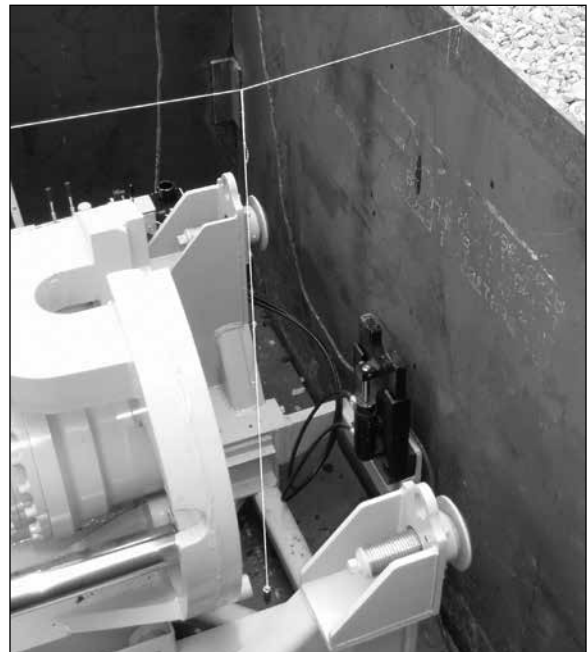

- d. Suspend the plumb bobs into a cup of oil to restrict the effects of air movement along the string lines. This will ensure a more accurate reading.

NOTICE Be sure plumb bob is free to move in oil. Do not allow the plumb bob to touch the bottom or sides of cup.

(continued on next page)



LEVELING THEODOLITE

2. Adjust theodolite until level with the adjustment knobs.



3. Once theodolite is level, rotate the theodolite 90° and adjust until level.



4. Repeat steps 2 and 3 until the theodolite is level in all directions.

(continued on next page)



5. Turn ON theodolite.



6. "TILT TELESCOPE" is shown on the theodolite LED display. Loosen vertical coarse adjust/lock knob (large knob) and rotate the telescope until "VA" and "HA" are displayed.



7. Tilt the telescope until VA is close to 90°.



8. Lock the telescope position with the vertical lock knob.



(continued on next page)

9. With the vertical fine adjust knob (small knob), adjust the VA reading until $90^{\circ} 00' 00''$ or 0.00% is displayed.

NOTICE

For more information, refer to Understanding Grade Degrees Versus Grade Percent, in the Specifications section.



10. Press %/VA button. Using vertical adjust knob (A), adjust the % of grade per the project requirement.

IMPORTANT! DO NOT USE THE HOLD BUTTON WITH THE GBM SYSTEM! Doing so will freeze the displayed horizontal angle readout which will remain unchanged regardless of theodolite directional movement.



⚠ DANGER

Staring into laser light will cause severe injury.

Do not stare into the laser sight light beam or the laser guidance system laser light beam. Avoid direct eye exposure. Do not aim laser at anyone's eyes.

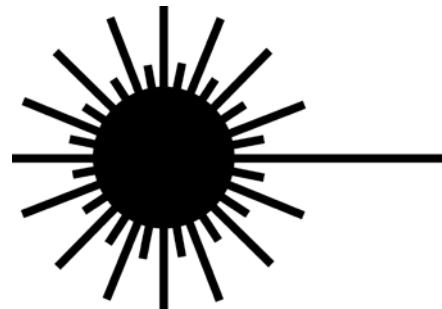

11. Turn the laser bore sight ON by turning the end cap clockwise until the laser light turns ON.

NOTICE

The battery life (fully charged) with the laser continuously ON is approximately 15 minutes. The battery life will be shorter in colder climates.



(continued on next page)

12. Slide the laser bore sight completely into the laser alignment holder.



13. Remove LED light cable from counterweight and thread the alignment holder/laser bore sight into the theodolite counterweight until it is snug against telescope.



SET/CHECK ELEVATION

14. Elevation is set by using a transit and surveying marks.

To check the elevation:

- a. Insert the target completely into the back of the drive motor. Do not turn on target.
- b. The laser bore light should be centered on the middle dot of the target.



SN 1 -3

SN 4 & After

- c. If the laser beam is not centered on the middle dot of the target, move the elevation of the theodolite until the laser beam is centered on the target's middle dot by: loosening column lock, raise or lower column with handle and relock column.

- d. Relevel theodolite.



(continued on next page)

15. Once laser beam is centered on middle dot of the target, remove the target from the drive swivel.

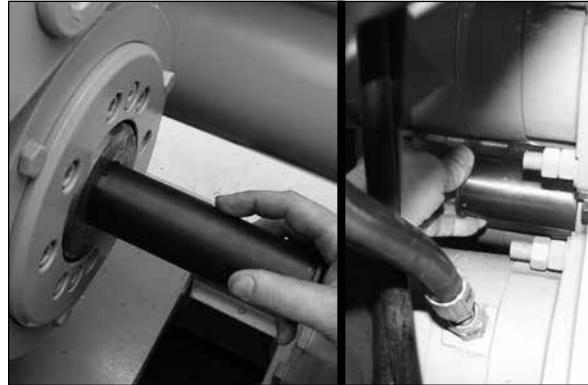

SN 1 -3

SN 4 & After

PRELIMINARY STRING LINE CALIBRATION

16. Using the horizontal fine tuning knob, adjust as needed to center the laser light with the front string line.

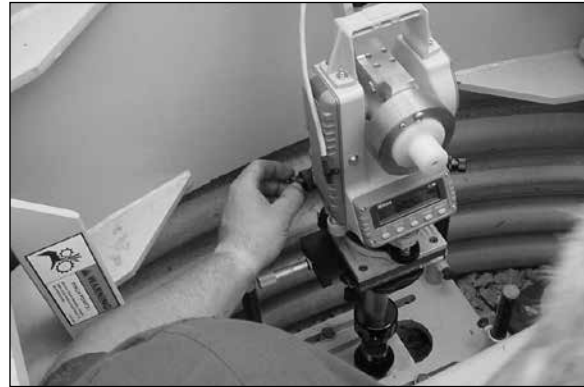

NOTICE Use a piece of paper or cardboard to help determine when the front line is centered in the laser light.



17. Using the lateral slide, adjust as needed to line up the laser light with the front string line.



(continued on next page)

NOTICE Use a piece of paper or cardboard to help determine when the back line is centered in the laser light.

18. Repeat steps 16 and 17 until both string lines are centered within the laser light.

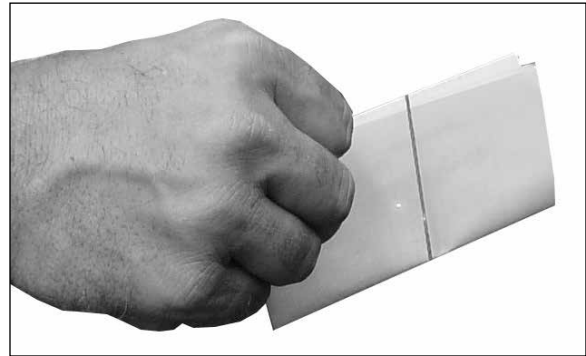

19. Press RESET on theodolite until the LED displays HA: 00° 00' 00"
20. Recheck level.



21. Unthread alignment holder/bore sight laser from counterweight.



22. Remove laser bore sight from the laser alignment holder by inserting rod (included) through hole in holder and gently push the laser bore sight out of holder.



(continued on next page)

⚠ DANGER

Staring into laser light will cause severe injury.

Do not stare into the laser sight light beam or the laser guidance system laser light beam. Avoid direct eye exposure. Do not aim laser at anyone's eyes.

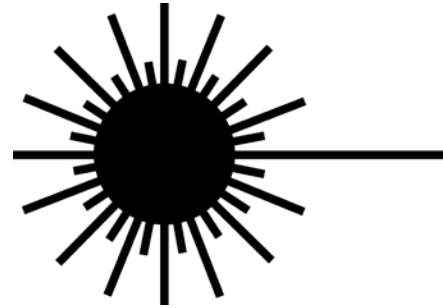

23. Turn the laser OFF by turning the end cap counterclockwise until laser light is OFF.
24. Replace laser bore sight and rod into storage case.



25. Replace the LED light cable to counterweight. The tip of the light must be directed into the telescope lens for the theodolite cross hairs to display on monitor.



26. Proceed to Tablet PC Start Up & Operation or to Final Theodolite Setup in this section.

TABLET PC START UP & OPERATION

NOTICE Before starting up tablet PC, be sure the theodolite zero point calibration is checked, and the guidance system is properly assembled.

1. Start power pack.
2. (P275 SN 1 - 4 Only) Flip the pendant 12V To Monitor & Control Panel switch (A) to the ON position.

NOTICE On the P150Q Power Pack and P275 Power Pack SN 5 and after, the pendant is not equipped with the 12V To Monitor & Control Panel switch (A). As soon as the power pack engine starts, the monitor and control panel switch are automatically turned on.

NOTICE If the 12V To Monitor & Control Panel switch is not ON, the tablet screen will display a No Camera Present window. If switch is Off, turn switch On, then restart GBM_System program. You do not need to restart computer.

NOTICE If you are connecting a new camera to a tablet PC for the first time, refer to Connecting New Camera, in this section, prior to powering up tablet PC as stated in item 2 below.

3. Power ON (B) tablet PC.
4. Check to be sure the PC power indicator light (C) and the Camera Power indicator (see inset) light (D) are illuminated. If not, refer to Checking Guidance System Camera Connections in this section.

4. Perform the preliminary theodolite setup for line and grade and the final theodolite setup. Refer to Preliminary Theodolite Setup For Line & Grade, and Final Theodolite Setup in this section.

(continued on next page)

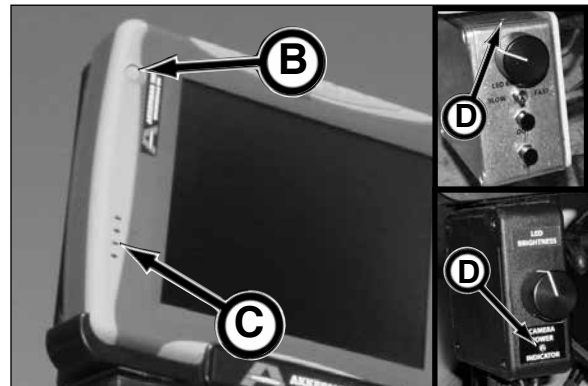
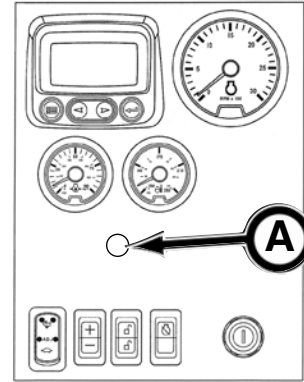

On & Off Control

To turn on (boot up) tablet PC, depress power button (A). The GBM_System program automatically loads once the Windows operating system is loaded.

NOTICE

If a DOS screen appears, the Windows operating system did not load properly. Refer to "Problem: Windows operating system and the Akkerman GBM_System ... A DOS screen appears" in section 11, Troubleshooting to resolve this issue.

To turn off or shutdown tablet PC power, close the GBM-System program, and depress power button (A) briefly (1 second).

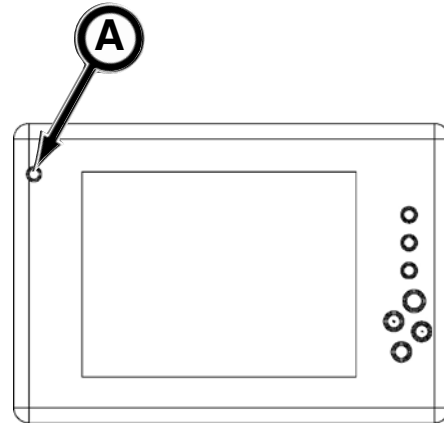

HARD POWER DOWN

NOTICE

Use this procedure ONLY as a last resort. This shutdown method will take significantly longer (in excess of 5 minutes) to reboot since the Windows program performs a Disk Check.

If computer does not respond when: depressing the tablet buttons, using the digitizer pen, computer fails to shutdown or is frozen; depress power button (A) and hold for 7 to 10 seconds. Also, refer to section 11, Troubleshooting.

Gain- Exposure-Zoom-Direction-Pipe Count-Status Control

Adjust the Gain, Exposure, Zoom, Left/Right, Up/Down, Pipe Count and Status fields using either the Select Up or Select Down buttons (B) until desired field is highlighted.

To increase or decrease the values in the fields, use the Up or Down buttons (C).

- Gain control adjusts the camera sensitivity.
- Exposure control adjusts the amount of light available to the camera.
- Zoom control adjusts the camera zoom lens in and out.
- Left/Right control moves the image left or right on the screen.
- Up/Down control moves the image up or down.

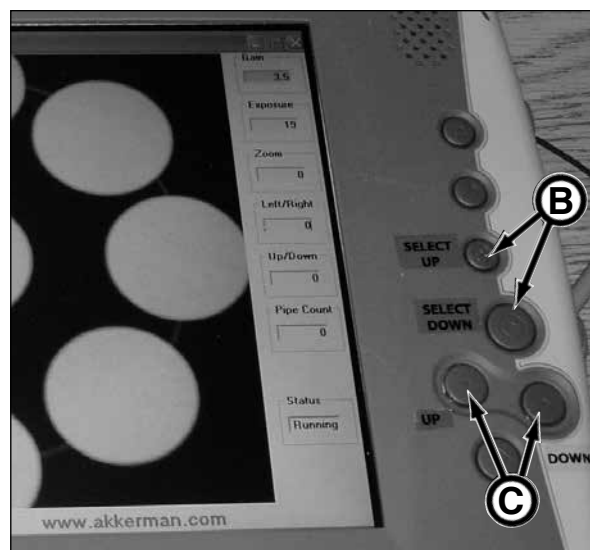

(continued on next page)

Using Digitizer Pen

When using pen, look on the pointer on the screen, not on the tip of the pen.

Use the pen for many of the same tasks you perform with a mouse:

1. *To select an item on the screen as you would with the left button of an external mouse:*

Tap the item with the tip of the pen.

2. *To double-click an item on the screen as you would with the left button of an external mouse:*

Tap the item twice with the tip of the pen. (You need to lift the pen from the tablet briefly and quickly between taps.)

3. *To select an item as you would with the right button of an external mouse:*

Press and hold down the pen button until a circle of red dots appear with a mouse icon, then lift the pen.

NOTICE

The pen must be held steady while performing the right click. Otherwise, the computer interprets that you are moving the mouse.

NOTICE

The button on the side of the pen does not function with the existing software configuration.

Accessing The Task Bar / Start Button

Access the task bar (A) at the bottom of the tablet screen to select start button, programs, control panel, etc.

With the digitizer pen at a 90 degree angle to the bottom of the tablet screen, hold pen for about one second and lift up pen to unhide the task bar.

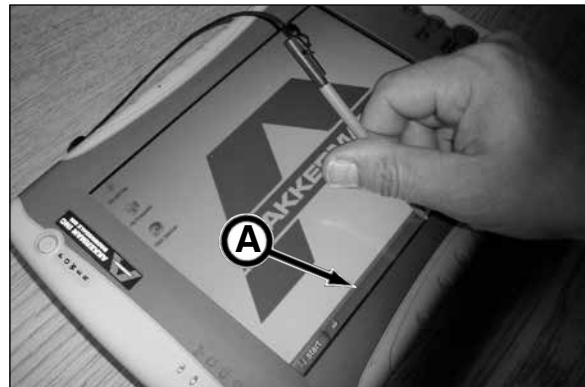

Entering Data

Data will be entered with the digitizer pen through the input panel. There are two ways to gain access to the input panel. Either click the Input Panel icon  on the task bar, or hover the digitizer pen over the character field in which data is to be entered, and click the input panel icon.

NOTICE

When hovering over a character field, a pause before use will cause the input panel to disappear. Simply hover over the character field to reactivate the input panel.

There are three ways to enter data via the input panel. On the left are three icons which represent the input methods:



writing pad. Simply write or print desired data and press INSERT.



character pad. Write or print an individual character in the character slots and press INSERT.



onscreen keyboard. Click each desired letter on the keyboard using the pen and press INSERT.

(continued on next page)

Using the Theodolite Remote Focus

The remote focus feature (standard equipment as of SN FA42035F-87 and after, otherwise a remote focus kit is available for SN FA42035F-86 and before) allows the operator to focus the theodolite image on the Tablet PC screen at the controls of the Tablet PC docking station instead of making the necessary adjustments directly on the theodolite focus ring.

The remote focus assembly is equipped with a dual speed focus adjustment; SLOW or FAST. Flip the toggle switch (A) as follows:

SLOW - use for fine focusing.

FAST - use for close or distant focusing.

Other Control Buttons:

- Depress the IN button (B) for gradual adjustment during close focusing.
- Depress the OUT button (C) for gradual adjustment during distant focusing.
- Buttons can be toggled quickly for fine focus adjustment.



*Guidance System
(SN FA42035F-86 &
Before) With Remote
Focus Control Kit*



*Guidance System
(SN FA42035F-87 &
After) With Remote
Focus Control -
Standard Equipment*

NOTICE

(If equipped with Remote Focus Kit [SN FA42035F-86 & Before]) When the red LED LIMIT light (D) is illuminated, focus is at the end of travel and you must release button, and then reverse travel direction. Holding button with red LIMIT light illuminated could cause damage to motor and/or belt. The green LED RUN light (E) illuminates when the motor is running.

NOTICE

(Tablet PC With Remote Focus [SN FA42035F-87 & After]) When the focus is at the end of travel, you will notice that there is no more focus adjustment or the belt will start slipping. Release travel button to prevent premature wear to motor or belt.

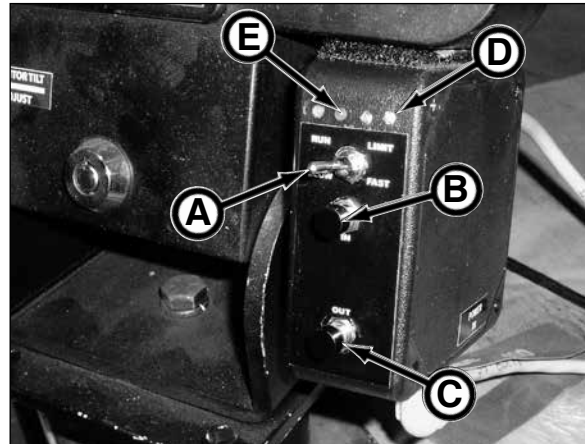

Remote Focus Control Kit (SN FA42035F-86 & Before)

(continued on next page)

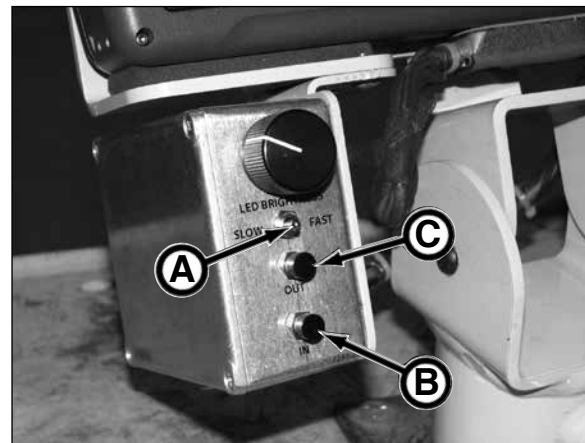

Remote Focus Control (SN FA42035F-87 & After)

Cleaning Tablet PC Screen

Use cleaning cloth (included) or other soft, lint-free cloth to clean dust, fingerprints, and smudges. DO NOT use solvents. Moisten with water, if necessary. The cloth is machine washable.



Docking Station - Removal / Replacement

NOTICE There are two styles of docking stations; an old and new style. When removing/replacing docking station, use the instructions for your style of docking station.

Old Style

Remove tablet PC from docking station (A) as follows:

1. Shut down tablet PC.
2. Insert key into docking station lock.
3. Turn key clockwise to unlock docking station/ computer fastener (B).
4. Carefully lift tablet PC to gain access to docking station connector (C).
5. Remove docking station connector from bottom of tablet PC (D) by loosening connector screws.

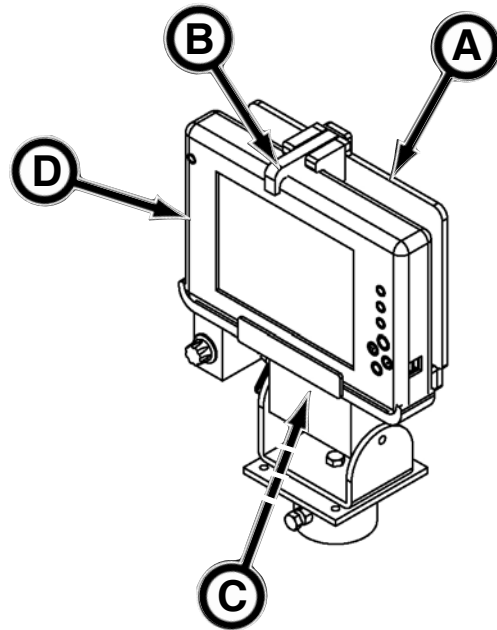

Replace tablet PC to docking station as follows:

1. With the docking station unlocked, fasten docking station connector (C) onto tablet PC by tightening connector screws. DO NOT overtighten.
2. Carefully mount tablet PC (D) into bottom tray of docking station (A).
3. While turning key counterclockwise, push fastener (B) down until computer is locked into place. Be sure hook of fastener mounts over tablet PC.
4. Remove key.

(continued on next page)

Docking Station - Removal / Replacement (continued)

New Style

Remove tablet PC from docking station as follows:

1. Shut down tablet PC (A).
2. Remove five bolts and rubber grommets (B) from docking station (C).
3. Carefully lift tablet PC to gain access to docking station connector (D).
4. Remove docking station connector from bottom of tablet PC by loosening connector screws.

Replace tablet PC to docking station as follows:

1. Fasten docking station connector (C) onto tablet PC by tightening connector screws. DO NOT overtighten.
2. Mount tablet PC to docking station by inserting five bolts and rubber grommets through docking station holes. Then line up bolts to tablet PC threaded holes. The rubber grommets must be located between the docking station and the tablet PC. Fasten bolts to tablet PC. DO NOT overtighten.

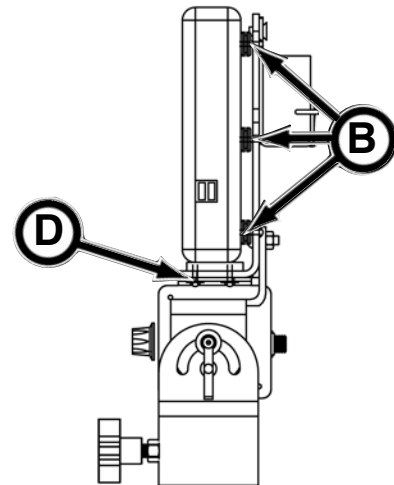
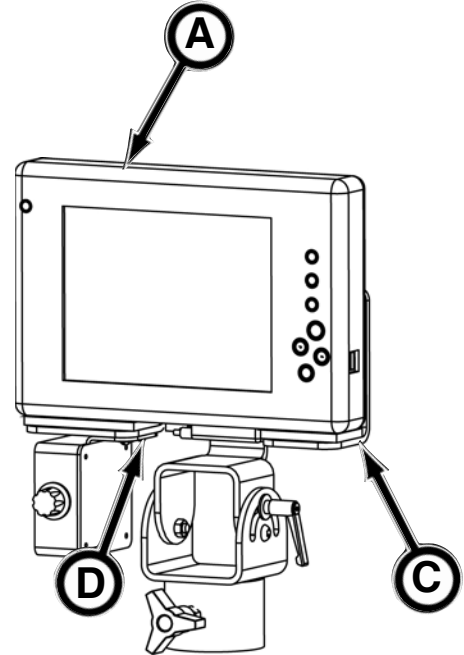

Connecting New Camera To Computer

When connecting a new camera to the tablet PC, the system requires you to reinstall the camera driver software.

1. Install guidance system (refer to Guidance System Installation in this section) but do not power up tablet PC at this time.



2. Start power pack.
3. (P275 SN 1 - 4 Only) Flip the pendant 12V To Monitor & Control Panel switch (A) to the ON position.

NOTICE On the P150Q Power Pack and P275 Power Pack SN 5 and after, the pendant is not equipped with the 12V To Monitor & Control Panel switch (A). As soon as the power pack engine starts, the monitor and control panel switch are automatically turned on.

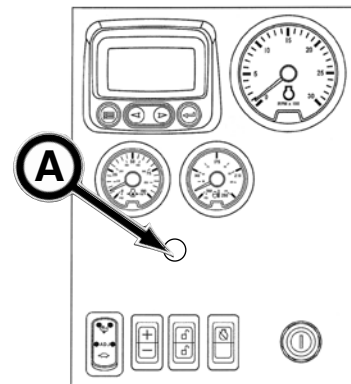

3. With camera connected to tablet PC, power ON tablet PC by depressing switch (B).

NOTICE Power is properly connected when both the tablet PC power indicator and the camera power indicator lights are illuminated.

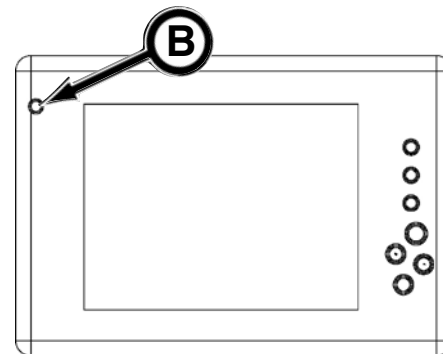

4. Since you are connecting to a new camera for the first time, a “No camera present” window (C) and “Found New Hardware” message window (D) will appear.

(continued on next page)

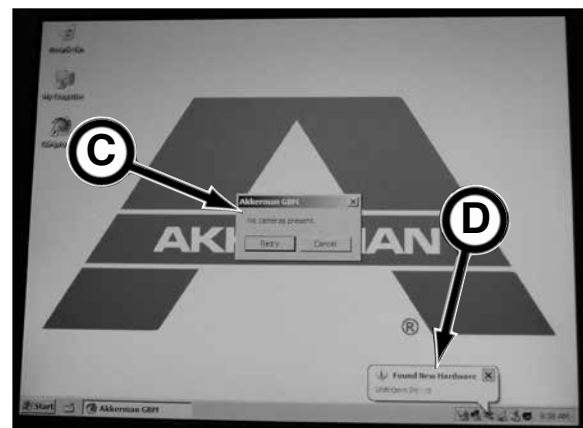

5. Wait approximately 30 seconds for the Found New Window Hardware Wizard window to appear.
6. In the wizard window, “Can Windows connect to Windows Update to search for software?” Click the “No, not this time” button (A), then click NEXT.



7. The next window asks “What do you want the wizard to do?” Click on Install the software automatically (Recommended) (B) and click NEXT. A window will appear that the driver has not been signed. Click continue anyway.
8. Continue to follow instructions as indicated in the windows.
9. Computer will need to be rebooted after installing camera driver.
10. If camera is still not recognized, contact your Akkerman Product Support representative.



Checking Guidance System Camera Connections

1. Start generator (if used) and power pack.
2. (P275 SN 1 - 4 Only) Flip the pendant 12V To Monitor & Control Panel switch (A) to the ON position.

NOTICE On the P150Q Power Pack and P275 Power Pack SN 5 and after, the pendant is not equipped with the 12V To Monitor & Control Panel switch (A). As soon as the power pack engine starts, the monitor and control panel switch are automatically turned on.

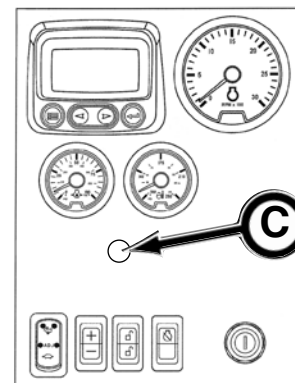

3. Turn ON tablet PC by pressing power button (D).
4. Check the following:

- a. Is the power indicator light (E) on the tablet PC lit? If not, either the generator or the power pack is not running, the 12V To Monitor & Control Panel switch is off, the power cable from pendant to Power In connection on tablet PC is not connected properly, or cable is damaged.
- b. (Some models) Is the Camera Power Indicator light (F) on the control box of the tablet PC assembly lit? If not, properly install camera cable connections, or replace damaged cable.

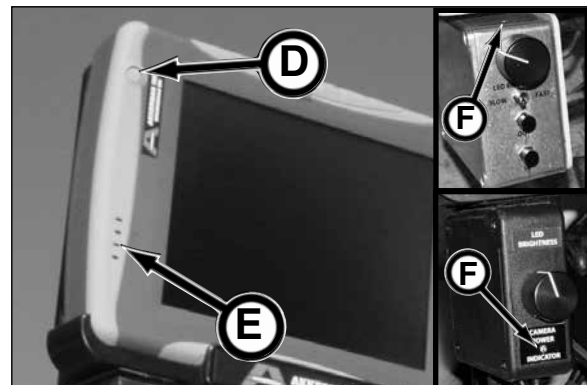

5. If camera still fails to function properly, refer to section 11, Troubleshooting.

FINAL THEODOLITE SETUP

1. Start power pack engine.
2. (P275 SN 1 - 4 Only) Flip the pendant 12V To Monitor & Control Panel switch (A) to the ON position.

NOTICE On the P150Q Power Pack and P275 Power Pack SN 5 and after, the pendant is not equipped with the 12V To Monitor & Control Panel switch (A). As soon as the power pack engine starts, the monitor and control panel switch are automatically turned on.

NOTICE (P275 SN 1 - 4 Only) The monitor power at the pendant must be turned OFF before starting engine.

NOTICE Engine RPM must be at least 1500 RPM to power tablet PC.

NOTICE If the 12V To Monitor & Control Panel switch is not ON, the tablet screen will display a NO Camera Present window. If switch is OFF, turn switch ON, then restart GBM_System program. You do not need to restart computer.

2. Turn ON tablet PC by depressing power button (B).

NOTICE If you are connecting a new camera to a tablet PC for the first time, refer to Tablet PC Start Up & Operation - Connecting New Camera in this section, prior to powering up tablet PC.

3. Turn ON target.

4. Insert the lighted target completely into the back of the drive motor.

(continued on next page)

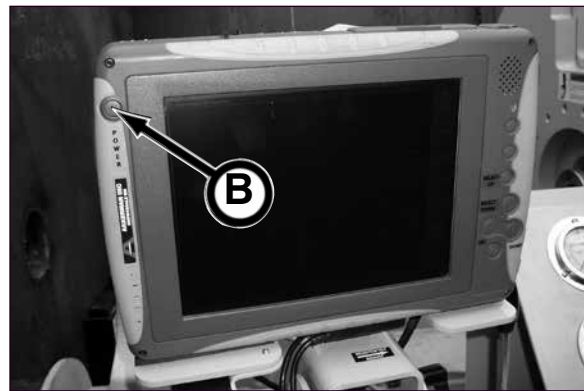
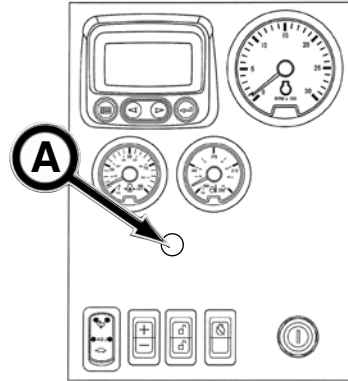

SN 1 -3

SN 4 & After

- Adjust the elevation as needed to center the middle dot of the target with the crosshairs on the monitor.

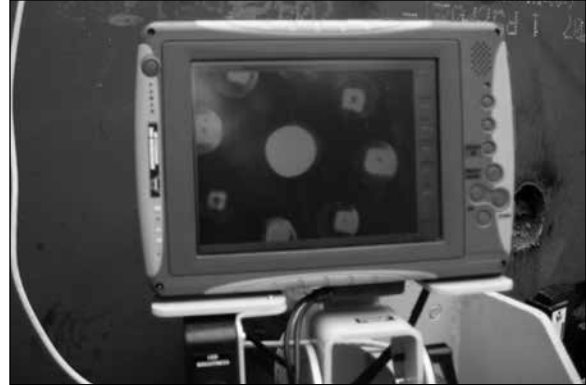

NOTICE To improve the target image and crosshairs on the monitor, use the Gain, Exposure, Zoom, Left/Right, Up/Down, and LED brightness controls on the monitor and the focusing ring on the theodolite telescope.

MONITOR STARTING POINT ADJUSTMENTS:

	<i>Gain</i>	<i>Exposure</i>
Target Set Up	2.5	20

Normal Operation: adjust accordingly

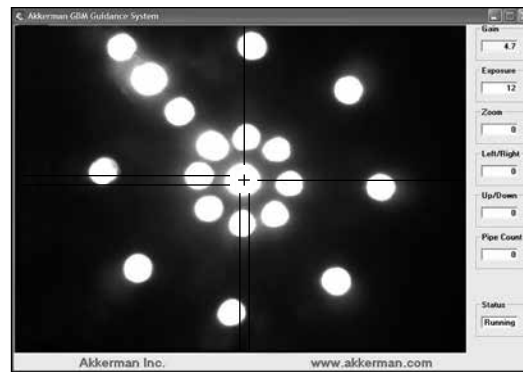

- Once elevation is adjusted, remove the target and turn OFF.



SN 1 -3

SN 4 & After

- Recheck your grade by pressing the %VA button. If necessary, adjust the % of grade by using the vertical fine adjust.

IMPORTANT! DO NOT USE THE HOLD BUTTON WITH THE GBM SYSTEM! Doing so will freeze the displayed horizontal angle readout which will remain unchanged regardless of theodolite directional movement.

(continued on next page)



NOTICE

ALL FOUR thrust block assembly wheels **MUST** be contacting the jacking frame rails. Failure to do so will result in wheel bearing failure. If this misalignment occurs, the GBM frame must be readjusted so the frame is on the same line and grade as the product pipe.

8. Relevel the theodolite, if necessary.



9. Center both the front and back string lines to the crosshairs on the monitor as follows:

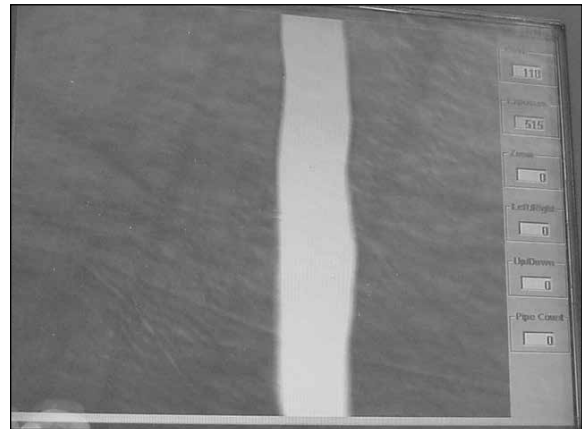

NOTICE

By adjusting the focus on the theodolite, the line image will change from the forward line to the rear line and vice versa. You may have to tap the string to determine which string you have focused.

a. Using the focusing ring on the telescope, focus on the string lines.



When you are able to focus on a string line, mark the focus location so you can easily go back to this location.

(continued on next page)



- b. Use the lateral slide to line up the back string line on the monitor crosshairs.

NOTICE The back string line will be wider and brighter than the front string.



- c. Use the horizontal fine adjust to line up the front string line on the monitor crosshairs.

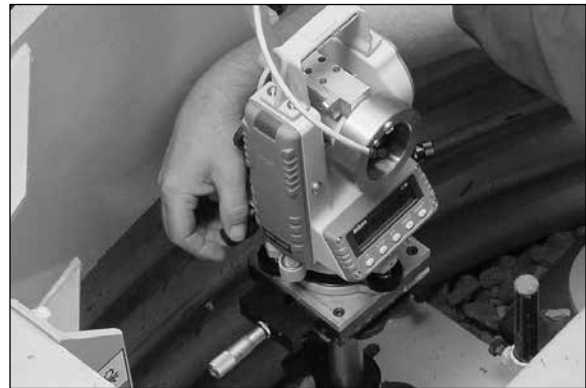

- d. Continue to line up the front and back string lines until they are both centered with the vertical crosshair on the monitor.

- e. Once the two strings are centered with the monitor crosshairs, the theodolite is now in line with the surveyor's marks.

NOTICE Due to ground shifting during jacking, you must periodically check the level of the theodolite to assure that the theodolite is aligned side to side and front to back. Also check to be sure the % of grade is correct.



10. Once string lines are set, press RESET and recheck level, elevation, and grade.

NOTICE After reset, the horizontal display must be at $0^{\circ}00'00''$ and must remain at $0^{\circ}00'00''$ until the end of the drive. In the event the theodolite is bumped or moved and the display is no longer at $0^{\circ}00'00''$, the operator must readjust the horizontal adjust back to $0^{\circ}00'00''$. Failure to do so will result in the drive being off line.



11. Proceed to Installing Pilot Tubes section.

Operation

NOTES

Operation - Installing Pilot Tubes

INSTALLING STEERING HEAD ADAPTER TO STEERING HEAD

1. Check o-rings (A) for damage. If damaged, replace with new.

Check to be sure that both o-rings are properly seated into target holder.

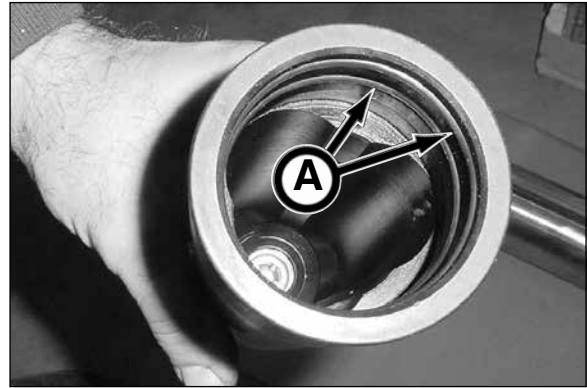

2. Remove cap on target. Turn the target LED lights ON and replace cap on target.



3. Slide target into target holder. Be sure the notch on the target aligns with pin (B) on holder.

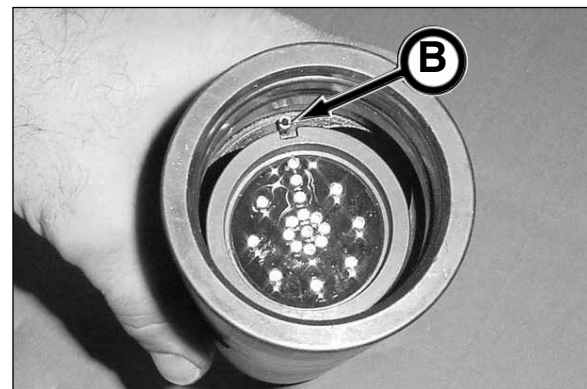

(continued on next page)

- Secure target to target holder by tightening three set screws with a 1/8" allen wrench.

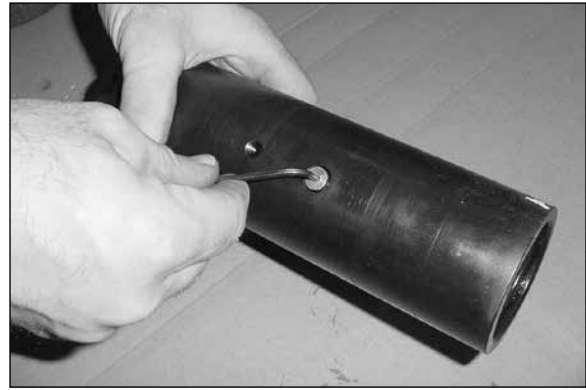

- Fully insert inner tube into target holder.



- Loosen three set screws on steering head adapter with a 3/16" allen wrench, so the target assembly can be slid into adapter.



- Remove the front 1/2 x 1-1/4 set screw for alignment purposes.

- Before installing the target assembly, note that the target holder cavity (A) must align with the adapter set screw hole (B).

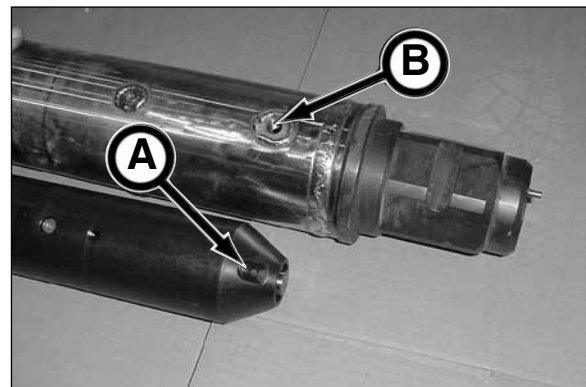

(continued on next page)

9. Slide target assembly into adapter. Be sure the target holder cavity aligns with the adapter set screw hole.



10. Reinstall the 1/2 x 1-1/4 in. set screw (removed in step 7) with a 1/4" allen wrench.



11. Tighten the other three set screws with a 3/16" allen wrench.



12. Check to be sure that the inner tube end of the target assembly is 1 in. (25.4 mm) from the end of the steering head adapter. If not, the target must be remounted until the 1 in. clearance is achieved.



(continued on next page)

13. Choose the steering head. Since ground conditions can change drastically, use the best steering head for your particular conditions based on the soil analysis. As a general rule:

<u>Ground</u>	<u>Steering Head</u>
Very Soft/Unstable	30° (4" Dia.) Head
Soft/Low Blow Count	30° (5" Dia.) Head
Medium	45° (5" Dia.) Head
Very Hard (High Blow Count)	Bullet Head

NOTICE

The steering heads have a lubrication port on its side.

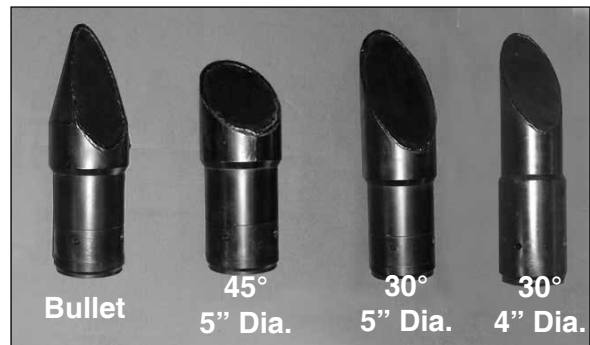

14. Check o-ring (A) for damage. If o-ring is damaged, replace with new.

Check that the o-ring is properly seated into steering head.

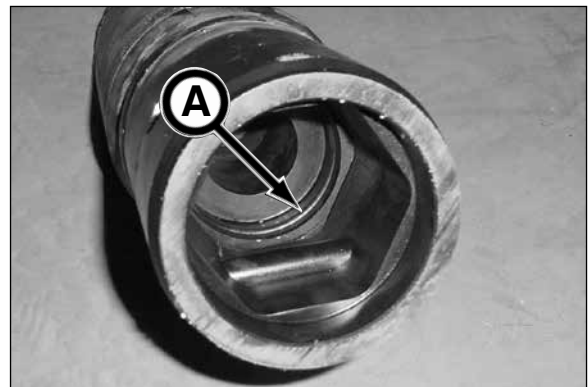

15. Install steering head to steering head adapter by aligning the adapter pin with the countersunk hole in the steering head. Be sure there is no gap between the adapter and steering head surfaces.



16. Secure steering head to adapter with connection pins (B) (2 places).

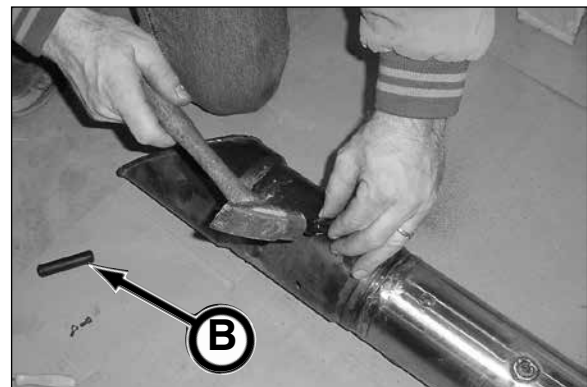

(continued on next page)

17. Place anti-seize lubricant on the 10-24 socket head cap screws (2). Install socket head cap screws to secure connection pins to steering head with a 5/32" allen wrench.



18. Put a small amount of pipe sealant on pipe plug and the lubrication plug threads. Install plug with a 1/4" allen wrench.

NOTICE If more flow is desired, upsize the hole in the lubrication plug.



19. Proceed to Installing Pilot Tubes in this section.

INSTALLING PILOT TUBES

⚠ WARNING Flying sparks and debris from torching operation can cause severe injury. Approved personal protection must be worn while torching opening into shaft wall.

1. Cut an opening in the shaft wall large enough for the steering head and pilot tube adapter to pass through.

NOTICE Based on soil conditions, a pit seal may need to be installed. Contact Akkerman for more information.



2. Connect power cable from pendant to the Power IN connection on the tablet PC assembly control box (as shown). This connection provides power for the guidance system and prevents the 200 ton electronic controls on the console from being activated.



NOTICE The alignment guide adapter (A) must be removed before installing steering head adapter.

3. With the swivel support (B) secured to push plate, slide the fluid swivel adapter into the internal hex of the thrust block shaft.

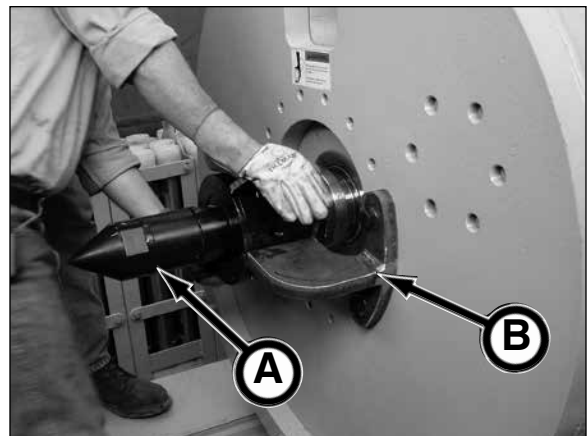

NOTICE When installing pilot tubes, run the P275T power pack engine at 1,000-1,500 rpm. Pilot tube installation does not require full engine horsepower.

NOTICE If you plan to pull back pilot tubes, secure pullback coupler around fluid swivel adapter and thrust block shaft with 1/2-13 UNC x 1.25 socket head cap screws.



(continued on next page)

NOTICE ALL FOUR thrust block assembly wheels **MUST** be contacting the jacking frame rails. Failure to do so will result in wheel bearing failure. If this misalignment occurs, the GBM frame must be readjusted so the frame is on the same line and grade as the product pipe.

4. Install steering head to steering head adapter.
See Installing Steering Head Adapter To Steering Head in this section.



5. Thread the steering head/steering head adapter onto drive swivel adapter by rotating the swivel clockwise (CW) using the drive rotation control.

NOTICE You must plan for lubrication during the drive, whether or not it is needed for the project. If a “change of conditions” occurs during the drive and lubrication is not setup, the pilot tubes may become unrecoverable without open trenching. Refer to page 6-30-10, step 18 for adding lubrication. Akkerman highly recommends to always use lubrication for the specific ground conditions on each job site. The lubrication will assist in lowering jacking and rotational pressures on the pilot tubes.



6. Advance steering head into the ground with the tip UP (see inset), by extending thrust cylinder control lever to the forward position.

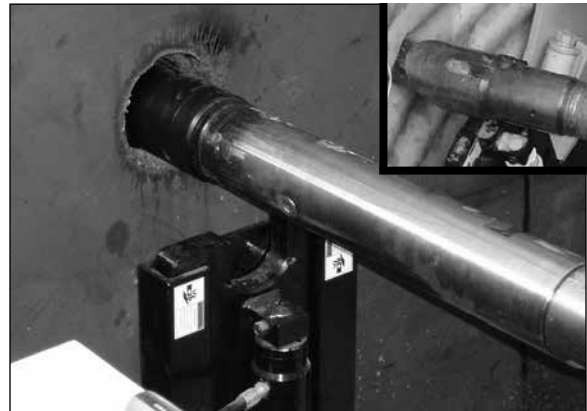

7. Push adapter until the notches in the steering head adapter line up with the tube support (A) in the make-up tool.

8. Engage the make-up tool tube support to the notches on steering head adapter by extending the Make Up Tool cylinder with control lever.

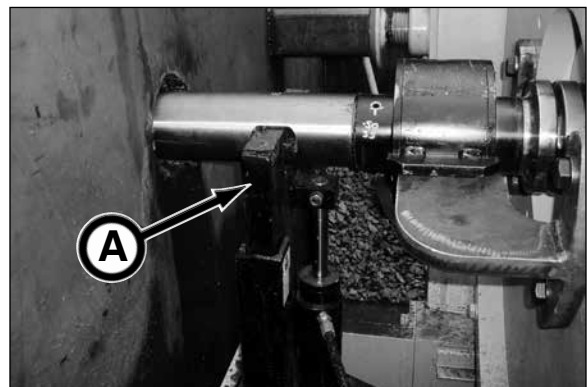

(continued on next page)

9. Disengage the drive adapter from the steering head adapter by rotating the drive CCW with the drive rotation control and using the thrust cylinder control to retract the thrust cylinders.

NOTICE Maintain a 1/2" to 1" maximum gap between the drive swivel hub and the thrust hub to allow for rotation/jacking mismatches.

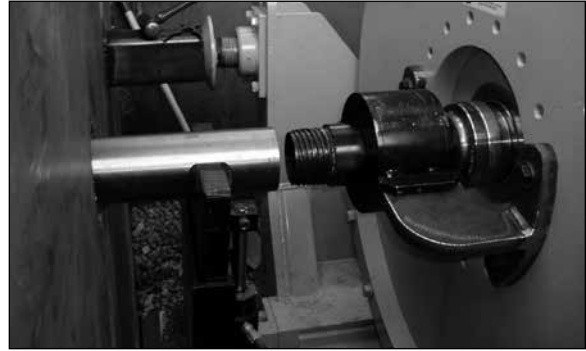

10. Move the rabbit/push plate (A) to the back of the GBM frame using the thrust cylinder control.

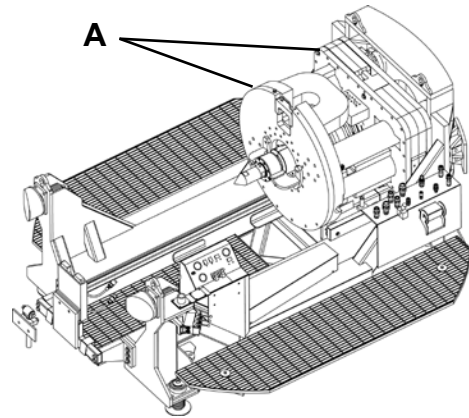

⚠ WARNING Suspended loads may fall and cause severe personal injury or death.

Do not enter area under or around a suspended load.



11. Lower a pilot tube rack into launch shaft.

NOTICE The operator platform MUST be supported from shaft floor BEFORE setting pilot tube rack in launch shaft. Failure to do so WILL damage the operator platform.



12. Remove cap and plug from a pilot tube and secure them together for storage.



(continued on next page)

NOTICE

BEFORE installing each pilot tube, inspect o-rings for damage. Replace if damaged. Also, wipe o-rings with a lubricant. DO NOT spray a lubricant on the o-rings. Doing so will make it difficult to identify the target on the monitor due to the reflection of the lubricant in the pilot tube.

NOTICE

If there is dust or dirt in the pilot tube threads, or poor thread lubrication, a high breakout torque and thread damage will occur. This will cause damage to the reception shaft breakout tool and/or other tooling and accessories. Be sure to ALWAYS store pilot tubes with clean caps and plugs attached, with threads well lubricated. Use Copper Guard-4 lubricant, part number P0310-778, or equivalent.



13. Place a pilot tube in-line with the steering head adapter and the drive swivel.
14. Advance push plate with thrust cylinder control while rotating the drive CW (using the drive rotation control) to thread the pilot tube to the drive assembly and steering head adapter.
15. Torque the connection to 500 psi (2,000 ft-lb) on rotation pressure gauge mounted on control console.

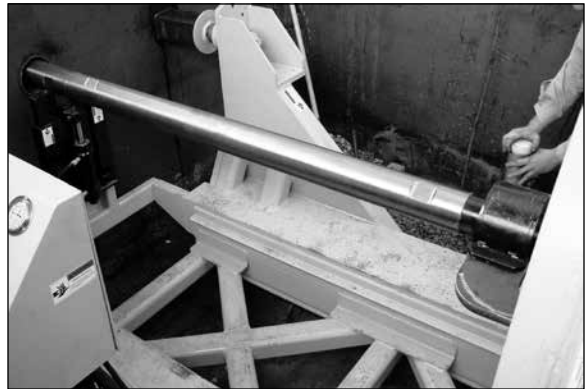

NOTICE

When installing or separating pilot tubes, maintain a 1/2 to 1" gap between the drive swivel adapter (A) and the thrust hub (B). Doing so will prevent thread damage

When advancing pilot tubes, the drive swivel adapter must be against thrust hub to prevent adapter or hub damage.

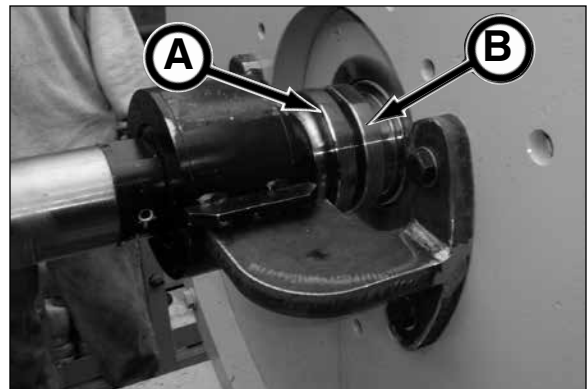

16. Release make-up tool to disengage tube support from steering head adapter by retracting make up tool cylinder with Make Up Tool lever.



(continued on next page)

17. Advance the pilot tube in ground by extending the thrust cylinders with thrust cylinder control.

While the pilot tube is advancing, check the target position often. Use the drive rotation control to align the target on line and grade. Always rotate the pilot tube CW. Rotating the pilot tubes CCW will unthread the pilot tubes in the pipeline resulting in unrecoverable pilot tubes.

NOTICE

The rotational working pressure range during pilot tube installation is up to 2,000 psi (13.789 MPa) of continuous operation, with a maximum pressure of 2,500 psi (17.236 MPa)



Also, check your jacking pressure on the jacking pressure gauge (A).

Working range is up to 5,000 psi (34.474 MPa).
Maximum pressure is 6,000 psi (41.368 MPa).

NOTICE

You must plan for lubrication during the drive, whether or not it is needed for the project. If a “change of conditions” occurs during the drive and lubrication is not setup, the pilot tubes may become unrecoverable without open trenching. Proceed to step 18 for adding lubrication. Akkerman highly recommends to always use lubrication for the specific ground conditions on each job site. The lubrication will assist in lowering jacking and rotational pressures on the pilot tubes.

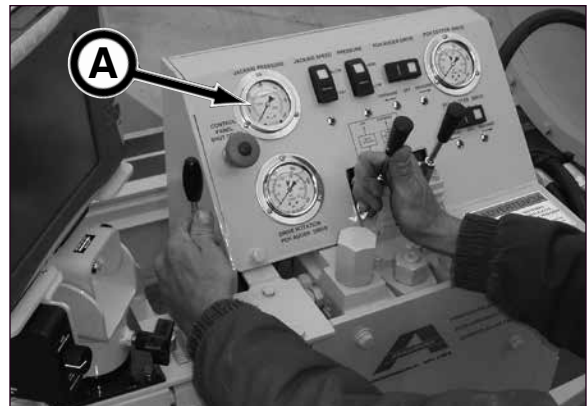

18. Use lubrication (do not use bentonite) to lower the jacking pressure. Generally, if the rotational pressure is running at 2,500 psi (17.237 MPa) and the pressure consistently increases, add lubrication as follows:

a. connect pump supply hose (B) to fluid connector adapter on drive swivel adapter.

NOTICE

To use pendant, switch to remote setting on control box (C).

b. turn on pump using pump pendant to control the lubrication flow, or use a ball valve to control the lubrication flow. Set pump pressure at 500 psi and pump flow at 1-3 gpm.

(continued on next page)

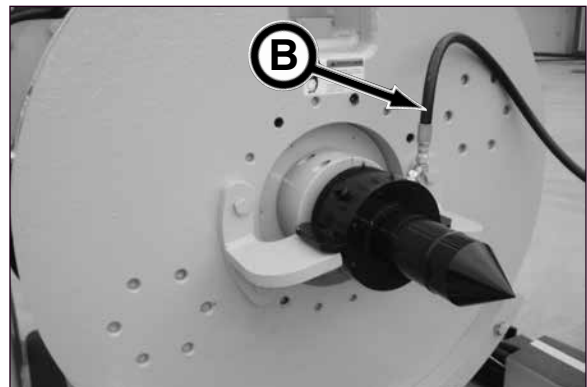

21. Continue adding pilot tubes by using the make up tool and frame travel control to thread the pilot tube connections until the steering head reaches the reception shaft.

NOTICE When advancing pilot tubes, ALL FOUR thrust block assembly wheels MUST be contacting the jacking frame rails. Failure to do so will result in wheel bearing failure. If this misalignment occurs, the GBM frame must be readjusted so the frame is on the same line and grade as the product pipe.

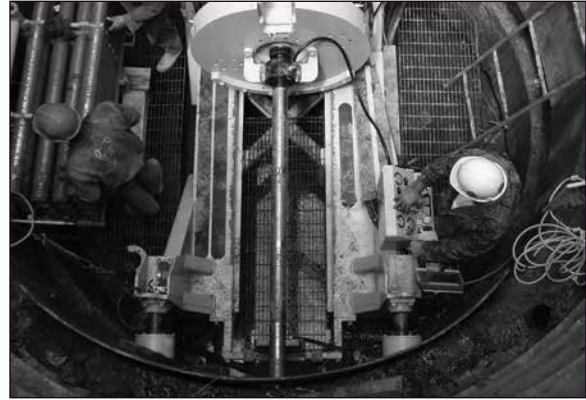

NOTICE Regularly maintain anchor block (A) tension on shaft wall during pilot tube installation by periodically checking screw tension while extending pilot tubes. Securing the frame to the shaft wall will keep the frame properly aligned with the pipe line.

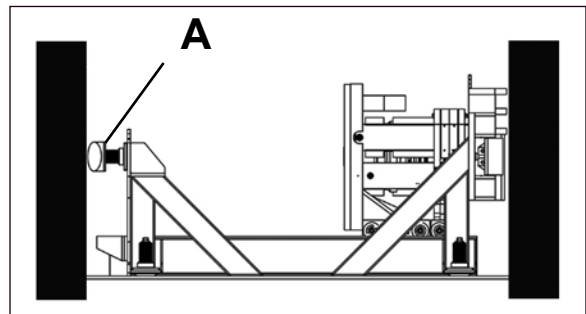

22. Once the steering head reaches the reception shaft, push the last pilot tube until the notches in the tube line up with the tube support on the make-up tool.



23. Engage the make-up tool tube support to the notches on the pilot tube.

24. Disengage the drive adapter from the pilot tube by rotating the drive CCW while retracting the jacking cylinders.



(continued on next page)

25. Remove the swivel support and drive swivel adapter from push plate.



CAUTION The drive swivel adapter weighs approximately 101 lbs. (46 kg). Be careful when handling swivel.



26. Proceed as follows using the desired method of pipe installation:

Three Step Method (Typical)

- If using a reaming head, proceed to “Three Step Method: Installing Auger Casings With Reaming Head” in this section, subsection Installing Upsizing Tool.

Power Cutter Head Method

- If using a powered cutter head, proceed to “Three Step Method: Installing Power Cutter Head” in this section, subsection Installing Upsizing Tool.

(continued on next page)

Operation - Installing Upsizing Tool

THREE STEP METHOD: INSTALLING AUGER CASING WITH REAMING HEAD

1. Remove guidance system from shaft and store in protective case.

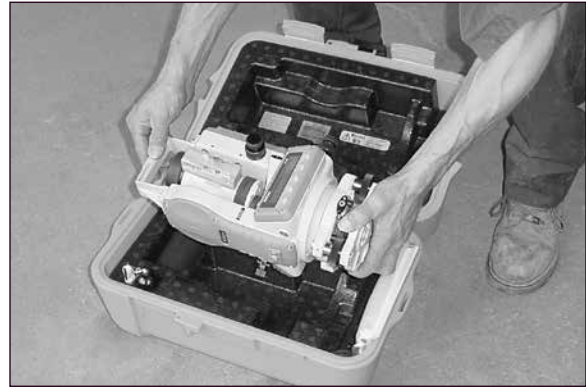

2. With the control pendant power cord removed from the tablet PC assembly control box, insert the connector into the control panel power supply 12VDC connection (A). This connection will supply power to the electronic controls (Jacking Speed, Rotation Pressure, PCH Auger Drive Rotation, and PCH Cutter Drive Rotation) on the control panel.

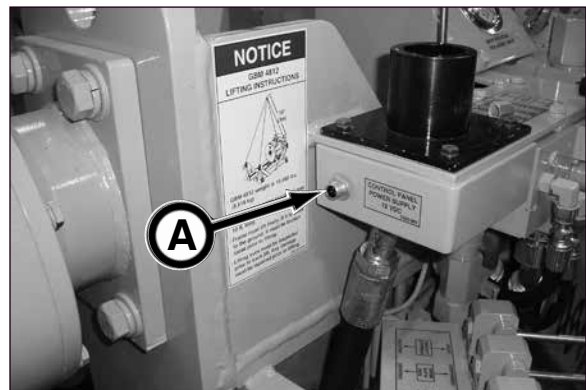

SN 1 - 3



SN 4 & After

- 3a. Start power pack engine.
- 3b. (P275 SN 1 - 4 Only) With the power pack engine running, flip the pendant 12V To Monitor & Control Panel switch (B) to the ON position.

NOTICE

On the P150Q Power Pack and P275 Power Pack SN 5 and after, the pendant is not equipped with the 12V To Monitor & Control Panel switch (B). As soon as the power pack engine starts, the monitor and control panel switch are automatically turned on.

(continued on next page)

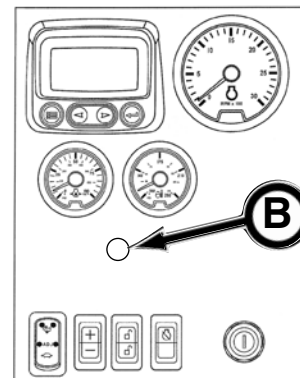

4. If not already removed, remove the drive adapter swivel and the swivel support from push plate.

CAUTION The drive swivel adapter weighs approximately 101 lbs. (46 kg). Be careful when handling swivel.

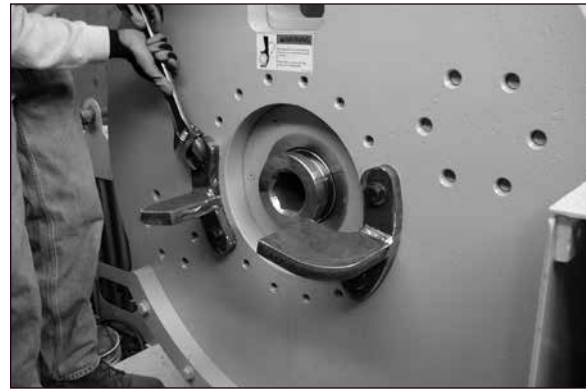

NOTICE Lubrication will lower jacking pressures during the drive. Refer to Upsizing Tool Lubrication From Reception Shaft in this section, page 6-35-20, to determine how to prepare the pilot tube adapter and reaming head fluid connector for lubrication requirements.

5. Lower the pilot tube adapter and Insert the pilot tube adapter hex into the thrust block internal hex.
6. With the last pilot tube locked into the make-up tool, thread the adapter into the pilot tube by rotating the adapter in the CW direction with the drive rotation control, while advancing the push plate with the thrust cylinder control.
7. Continue to tighten the connection to 500 psi (2,000 ft-lb) torque as shown on the gear box cover pressure gauge.
8. Release make-up tool.
9. Advance adapter into ground until there is enough room to pin the pilot tube adapter to the reaming head assembly.

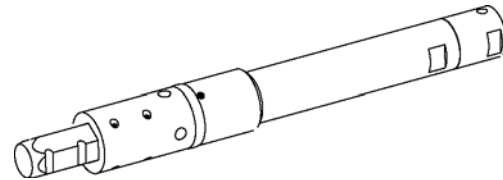

NOTICE For ease of installing reaming head, you may need to rotate the adapter to be sure the four pin holes are in the vertical (up and down) position (see inset).

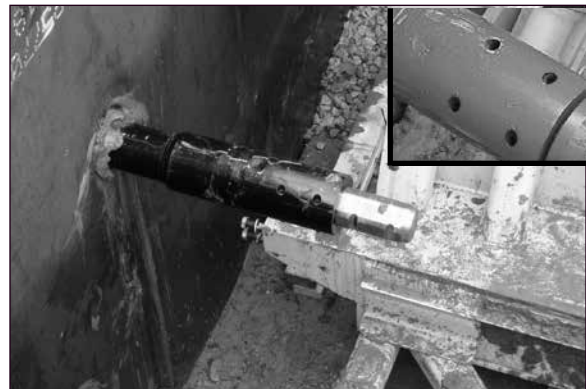

10. Remove make-up tool.
11. Move rabbit/push plate to the back of the GBM frame to allow enough room for the dirt bucket and reaming head assembly using the thrust cylinder control.



(continued on next page)

NOTICE

Lubrication will lower jacking pressures during the drive. Refer to Upsizing Tool Lubrication From Reception Shaft in this section, page 6-35-20, to determine how to prepare the pilot tube adapter and reaming head fluid connector for lubrication requirements.

12. Remove hex coupler from pilot tube adapter by removing pins.



13. Mount a roller bracket (A) to shaft wall or make-up tool mount.



14. Remove middle operator platform.



15. Lower dirt bucket into shaft. Be sure to position dirt bucket so the push plate does not contact dirt bucket while jacking. Doing so will cause damage to dirt bucket and jacking frame.

NOTICE

There are various sizes of dirt buckets available depending on jacking frame elevation. The larger the dirt bucket, the less it will need to be emptied, resulting in higher productivity.



(continued on next page)

16. In the reception shaft, remove steering head.

a. Remove set screw.



b. Drive out pins.



c. Remove pins.



d. Remove steering head.



(continued on next page)

17. Once the steering head adapter and the pilot tubes reach the reception shaft, each joint must be loosened with the breakout tool.

Hook up the breakout tool as follows:

Clean the areas around the oil ports. Install base end cylinder hose to port A and rod end cylinder hose to port B.

Selector Position:
Port A - Extend
Port B - Retract

⚠ WARNING Electrical shock hazard could cause severe injury or death. Be sure the breakout tool power unit, plug and receptacle (must be three-pronged) are properly grounded and dry before plugging in and during operation.

Plug the breakout tool into 120 VAC outlet. If an extension cord is necessary, you must use a three-prong grounded extension cord.



18. Use the pilot tube scraper to remove mud from steering head adapter (shown) and pilot tubes.



19. Install cap on steering head adapter and pilot tube threads.



(continued on next page)

20. Place jaw insert on notches of back pilot tube.



21. With the cylinder retracted, slide the breakout tool onto the pilot tube and over the previously installed jaw insert from step 40 as shown.

NOTICE The cylinder side of the breakout tool is deeper than the other side. This allows the breakout tool to slide over both jaw inserts when loosening the pilot tube joints.



22. Slide other jaw insert on notches of the steering head adapter or the front pilot tube.



23. Slide breakout tool over both jaw inserts.

NOTICE You may have to extend or retract the cylinder to line up the jaw insert teeth with the breakout tool gear teeth.



(continued on next page)

24. Move the control lever to port A to extend the cylinder.



25. Extend cylinder by depressing the switch on the remote controller.



NOTICE The rocker switch on the pump unit can also be used to control the cylinder.



26. Continue to extend the cylinder until the joint is loosened. You should be able to hear and feel a “snap” when the joint is loosened.

27. Release switch on controller.



(continued on next page)

28. Once the joint is loosened, move the control lever to port B.



29. Slightly retract the cylinder until the breakout tool can be slid towards the launch shaft.
30. Remove the front jaw insert.



31. Slide the breakout tool towards the end of the tube and remove the back jaw insert.
32. Slide the breakout tool towards the launch shaft for the next joint removal.



33. Remove the pilot tube and immediately install a plug on the end of the pilot tube to prevent dirt from entering pilot tube.
34. Place pilot tube into pilot tube rack.



(continued on next page)

35. Install a cap on the end of next pilot tube to be removed.

NOTICE If there is a hose in the center of the pilot tube for lubrication, the pilot tube must be removed before capping.



36. Continue to remove pilot tubes as they reach the reception shaft. Place the pilot tubes in the pilot tube racks.



37. Install casing thrust adapter (A) to push plate with (SN1-2) sixteen 3/4 x 1.5 in. bolts and washers. (SN3-4) eight 3/4 x 2 in. bolts and washers or sixteen 3/4 x 2 in. bolts and washers depending on casing thrust adapter.

WARNING NEVER operate GBM without hinged cover (B) lowered in place as shown. Failure to do so can cause serious personal injury from contact of moving auger.

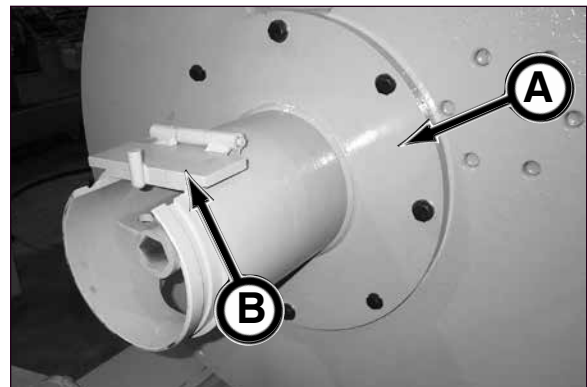

38. Install auger drive adapter into thrust hub.

(continued on next page)



NOTICE

Lubrication will lower jacking pressures during the drive. Refer to Upsizing Tool Lubrication From Reception Shaft in this section, page 6-35-20, to determine how to prepare the pilot tube adapter and reaming head fluid connector for lubrication requirements.

39. Route a supply hose through the pilot tubes and pilot tube adapter from reception shaft to launch shaft to lubricate the outside of casings as follows:

1. Punch a hole in a cap that is less than two inches in diameter.
2. Route a nylon string through the hole and tie a knot large enough so the string will not come back through the cap.
3. At the launch shaft, place the cap/nylon string in the pilot tube and use compressed air to blow the cap/nylon string through the pilot tubes and pilot tube adapter until it reaches the reception shaft.
4. Remove the cap from the string, then secure a 1/4" minimum nylon rope to the nylon string.
5. Pull the nylon string/nylon rope until it reaches the launch shaft.
6. Secure a 5/8" supply hose to the nylon rope and pull the rope until the hose reaches the reception shaft. Be sure female end of hose is at the launch shaft. Remove rope from hose.

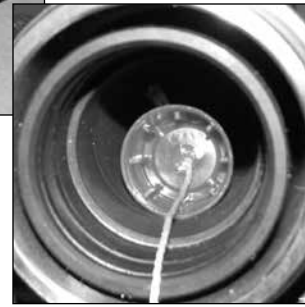
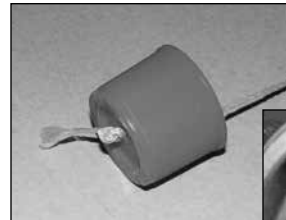

⚠ WARNING

Suspended loads may fall and cause severe personal injury or death.

If a hydraulic hose from the boom of a crane or excavator breaks, the boom and load can fall instantly.

Do not stand or walk under a load.

⚠ WARNING

Auger may fall out of casing and cause severe injury or death if casing tips or hits an obstruction.

Properly install safety chain assembly or casing auger pin to augers and casings before lowering into or lifting out of shaft. Refer to Installing Safety Chain Assembly/Casing Auger Pin To Auger & Casing in this section.

Do not stand or walk under a load.

40. Lower reaming head assembly into shaft and install fluid connector to reaming head.

NOTICE

Use a properly rated pipe tong or nylon strap to handle the reaming head assembly and casings.

(continued on next page)



41. Connect supply hose to fluid connector on reaming head and insert reaming head hex shaft into pilot tube adapter and secure with four roll pins.



42. Install auger drive adapter onto auger shaft.

NOTICE

For best assembly, align flats on outside of auger shaft adapter and flats on auger drive shaft. Failure to do so will cause premature wear to auger components.

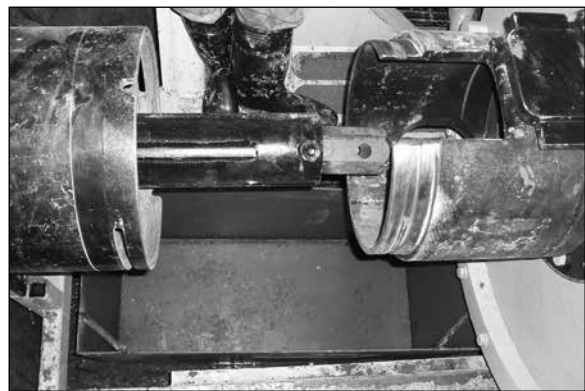

43. Align and engage auger drive adapter with the reaming head auger shaft and the hex opening in thrust block using the drive rotation control and thrust cylinder control.



(continued on next page)

44. Using hoist, align notches in reaming head casing with top alignment guide (A) and bottom alignment guide (not shown) on thrust plate.

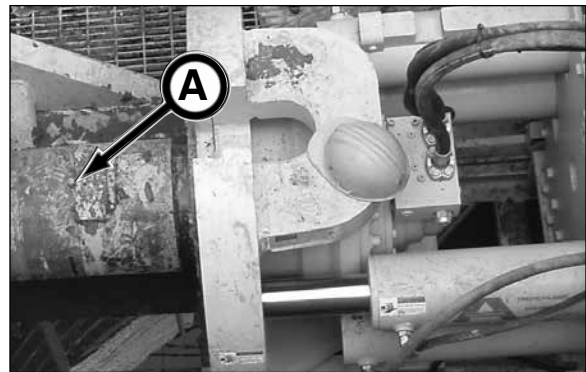

⚠ WARNING Flying sparks and debris from torching operation can cause severe injury. Approved personal protection must be worn while torching opening into shaft.

45. Cut an opening in the shaft large enough for the reaming head, thrust casings, powered cutter head (if used) and product pipe to pass through.



46. Select the jacking speed (B) and rotational pressure (C) switches on the control console as follows:

- a. When using the standard/100 ton thrust casings (2" hex), set jacking speed to Fast and set rotational pressure to Low.

NOTICE NEVER use the standard/100 ton thrust casings (2" hex) in the Slow jacking speed position and the High rotational pressure position. Doing so will damage the thrust casings and augers.

- b. When using the heavy duty/200 ton thrust casings (3" hex), set jacking speed to desired Fast or Slow position, and set rotational pressure to High.

NOTICE Rotation operating range in low pressure is up to 2,000 psi (13.789 MPa) with a maximum pressure of 2,500 psi (17.236 MPa). Rotation operating range in high pressure is up to 4,000 psi (27.579 MPa) with a maximum pressure of 5,000 psi (34.474 MPa).

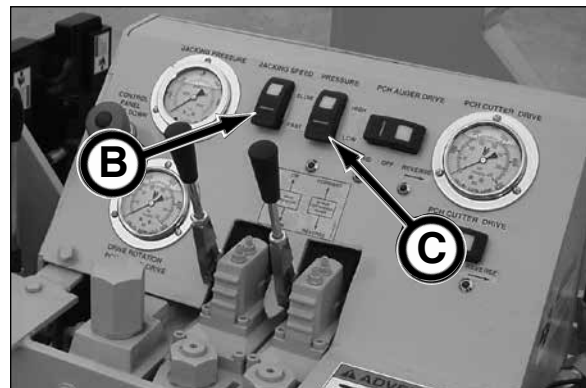

(continued on next page)

⚠ WARNING NEVER open chamber door on casing thrust adapter while auger is rotating. Severe injury may result from contact with rotating auger.

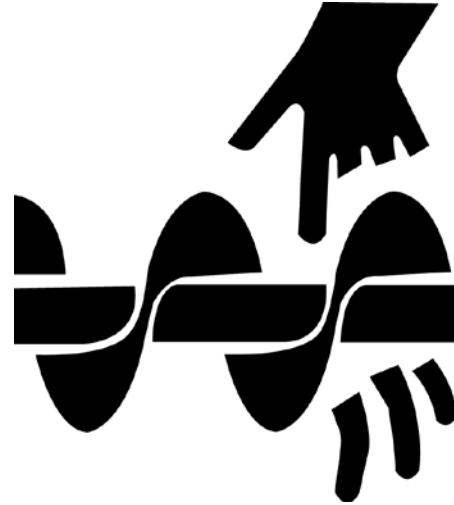

47. Advance the reaming head assembly by extending the thrust cylinders with the thrust cylinder control and rotate the augers in the clockwise direction with drive rotation control.

NOTICE Rotate the augers and advance the casings so small clumps of spoil are going into the dirt bucket. Over advancing the casings will restrict the flow of material out of the auger resulting in the spoils plugging in the spoil chamber (A) of the casing thrust adapter.

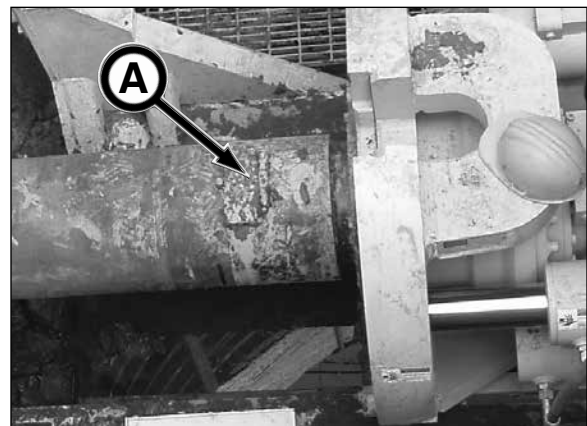

48. Continue to advance the reaming head assembly the full length of the frame.

NOTICE Lubricant can be pumped from the reception shaft to lubricate the spoils and casings to reduce jacking forces. Install fluid connector on end of pilot tube in the reception shaft. Refer to “Upsizing Tool Lubrication From Reception Shaft” in this section for configuration details.



49. Before retracting rabbit/push plate, adjust roller bracket (B) to casing by loosening clamp, slide roller into position, and retighten clamp. The roller will support the casing while the rabbit/push plate is retracted.

50. Move the rabbit/push plate to the back of the GBM frame using the thrust cylinder control.

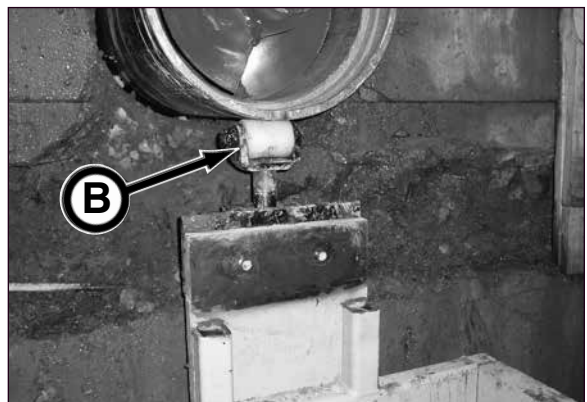

(continued on next page)

⚠ WARNING Moving parts or the mishandling of parts can cause severe personal injury. Handle parts carefully to avoid crushing and pinch point hazards. Properly install safety chain assembly to augers and casings before lowering into or lifting out of shaft.

51. Lower thrust casing/auger into launch shaft.

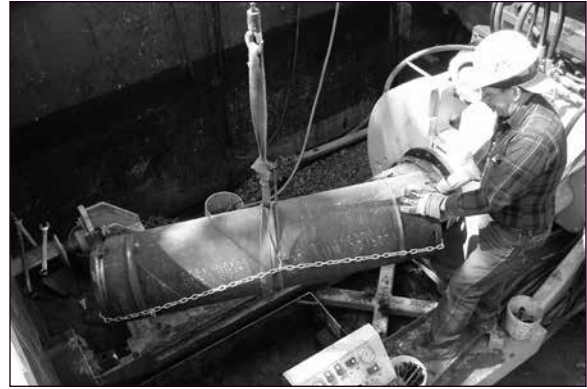

⚠ WARNING Safety glasses must be worn while using power equipment (air tools). Failure to do so could cause severe injury from flying debris.

52. Slide the thrust casing auger onto the end of the reaming head assembly auger shaft.

NOTICE Auger hex connection bolt hole from reaming head assembly must be beyond end of casing to be able to mount bolt in auger joint.

53. With the auger flighting lined up, attach the auger ends with one 3/4 x 4 in. bolt for 2" hex or one 3/4 x 6 in. bolt for 3" hex, and nylock lock nut. Tighten the nut so the end of the nut is flush with the end of the bolt. Do not overtighten.



54. Advance the casing to the reaming head assembly casing and align with alignment guides in the 12 o'clock (A) and 6 o'clock positions.

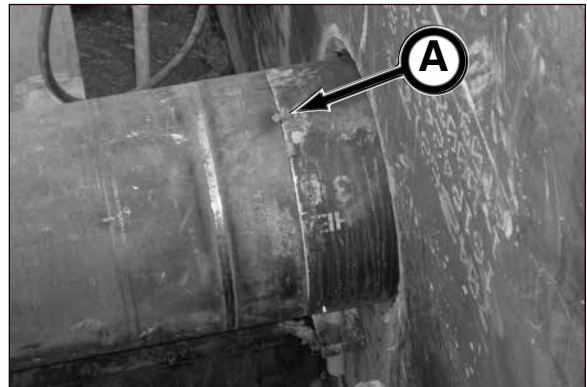

(continued on next page)

55. Install four casing joint keepers at the 2 o'clock, 4 o'clock, 8 o'clock, and 10 o'clock positions to lock the casings together.



56. Remove auger drive adapter (B) from thrust hub and insert onto casing auger shaft.

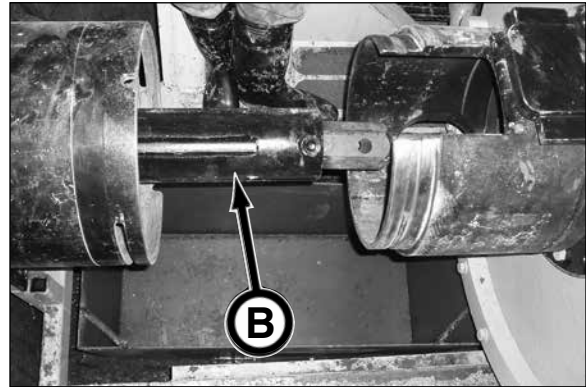

57. Align the auger drive adapter into the thrust hub while aligning the notches in the casings with the alignment guides (C) on thrust adapter using the drive rotation control and thrust cylinder control.

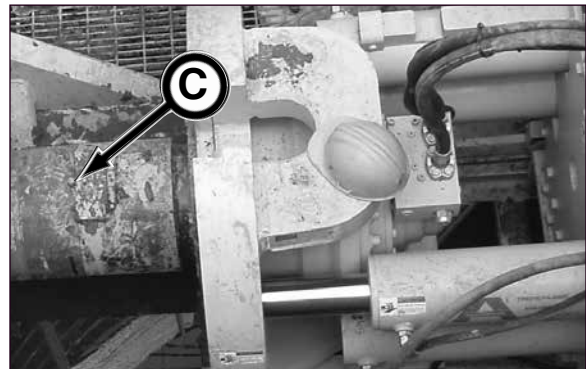

NOTICE

BEFORE rotating augers, the casings must be fully engaged with alignment guides on thrust plate. This prevents the casings from rotating with the augers.

58. Start rotating augers with rotation (CW) control and then advance the casing/auger with the thrust cylinder control.

NOTICE

With the addition of each section of casing/auger, a section of pilot tube will be removed in the reception shaft. Refer to procedure starting with step 17 on page 6-35-5.



(continued on next page)

NOTICE (5 ft thrust casings only) Once the 5 ft thrust casing is fully advanced, a thrust casing spacer (A) must be placed between the casing thrust adapter and the casing. Then advance the casing with the thrust cylinder control. This step provides additional space for ease of installing the next casing and auger.

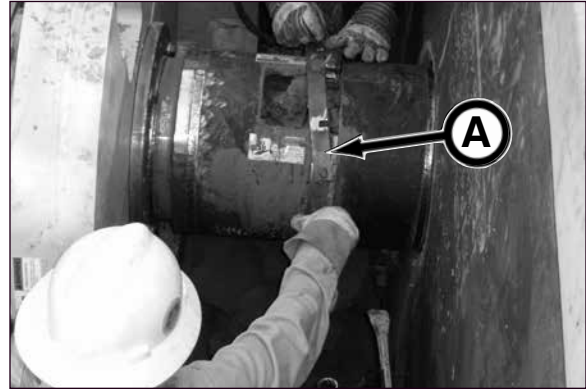

59. Periodically empty the dirt bucket.

NOTICE Do not allow dirt bucket to overflow and interfere with machine travel. Keep rails clear of debris.



60. Replace dirt bucket.

NOTICE Be sure dirt bucket will pass between legs on the push plate trolley. Failure to do so will cause damage to frame and dirt bucket during frame operation.



61. Continue to add casings and augers until all pilot tubes and the reaming head assembly are removed from reception shaft.

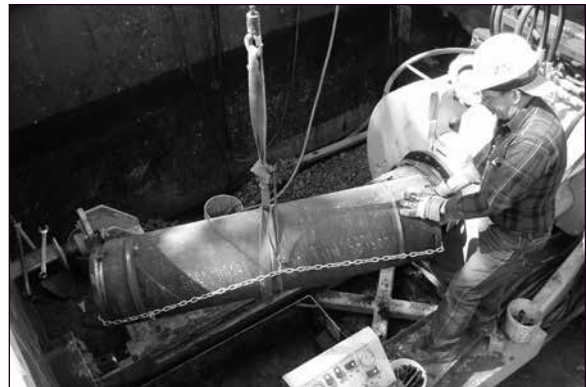

(continued on next page)

NOTICE

Regularly maintain anchor block (A) tension on shaft wall during pilot tube installation by periodically checking screw tension while extending pilot tubes. Securing the frame to the shaft wall will keep the frame properly aligned with the pipe line.

NOTICE

When advancing thrust casings, PCH or product pipe, ALL FOUR thrust block assembly wheels MUST be contacting the jacking frame rails. Failure to do so will result in wheel bearing failure. If this misalignment occurs, the GBM frame must be readjusted so the frame is on the same line and grade as the PCH/product pipe.

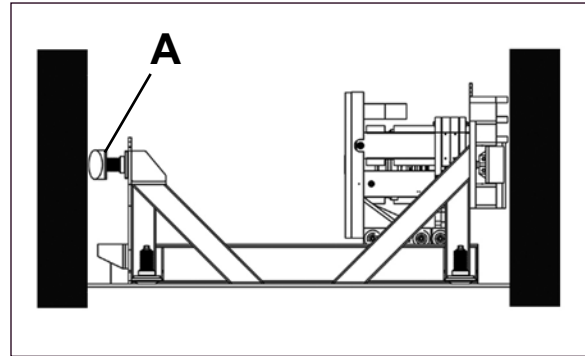

62. Once the pilot tube adapter reaches the reception shaft, remove the last pilot tube with the breakout tool from the pilot tube adapter, cap and plug the pilot tube, and place into pilot tube rack.

NOTICE

The 30" pilot tube is shown.



63. Remove the pilot tube adapter by removing four roll pins from the pilot tube adapter and reaming head assembly connection. Be sure to cap the threaded end of the adapter.



(continued on next page)

⚠ WARNING

Contact with rotating auger can result in serious injury. Before operating the auger, be sure all personnel in the launch and reception shafts are clear of any moving parts. DO NOT operate augers when removing auger in the reception shaft.

64. Once the reaming head assembly can be removed from the reception shaft, remove the keepers from the reaming head assembly and lead casing.

NOTICE

Using a hoist to keep the reaming head in line with the pipe line, remove bottom keepers first, otherwise the weight of the casing and auger will make it difficult to remove the bottom keepers once the top keepers are removed.



65. Slide the reaming head assembly casing forward to gain access to the auger connection.



66. If your next step is to install the final product pipe, place a block/spacer between auger thrust adapter (A) and auger (B). Push the auger forward with the thrust cylinder control to gain access to the auger connections in the reception shaft for removal.

NOTICE

If using a PCH, the auger hex connection must be exposed for connecting the PCH front section to the auger.

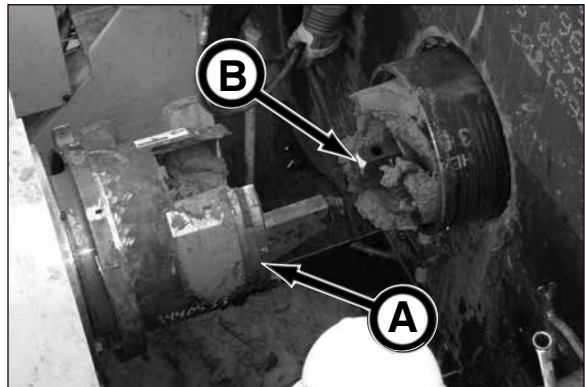

(continued on next page)

67. In the reception shaft, remove the reaming head auger by removing the auger bolt and nut that was installed in the launch shaft (back bolt as shown). Replace auger into the reaming head assembly casing.



⚠ WARNING Auger may fall out of casing and cause severe injury or death if reaming head assembly tips or hits an obstruction.

Properly install safety chain assembly or casing auger pin to augers and reaming head/casings BEFORE lowering into or lifting out of shaft.

Do not stand or walk under a load.

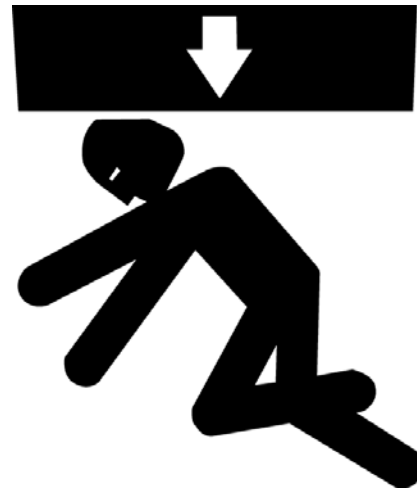

68. Install safety chain assembly or casing auger pin to auger to secure auger into reaming head assembly. For proper installation of safety chain or casing auger pin, refer to Installing Safety Chain Assembly/Casing Auger Pin To Auger & Casing in this section.

69. Remove the reaming head assembly from reception shaft.

70. Proceed to “Three Step Method: Installing Product Pipe” in this section, subsection Installing Product Pipe.

OR

If using powered cutter head, proceed to Three Step Method: Installing Powered Cutter Head in this section.



UPSIZING TOOL LUBRICATION FROM RECEPTION SHAFT

The upsizing tool can be lubricated from the reception shaft to lower jacking pressures using the reception shaft fluid connector, pilot tube adapter and upsizing tool fluid connector. Use a suitable ground lubricant, such as Baroid EZ-MUD® borehole stabilizer/viscosifier or CON DET® wetting agent.

The lubrication used when installing pilot tubes varies depending on the soil conditions. In most clay type of soils Baroid EZ-MUD® or equivalent is all that is required. In some clays Baroid CON DET® or equivalent should be added to the mix to reduce jacking and rotation operating pressures. In unstable soils use Baroid BORE GEL® boring fluid or equivalent with NO SAG® suspension enhancer to the mixture to prevent the rotation operation of the pilot tube from eroding the bore hole.

The pilot tube adapter contains three external lubrication ports for lubricating the spoils by connecting a lubrication hose to the reception shaft fluid connector. The casing can be lubricated by the pilot tube adapter's three internal lubrication ports connected to the upsizing tool fluid connector or by connecting a lubrication hose through the reception shaft fluid connector to the upsizing tool fluid connector.

I. Pilot Tube Adapter With Reaming Head Assembly

NOTICE

Plug A (not supplied) is a 1/4" NPT plug. Plug B (supplied) is a 1/8" NPT plug.

1. To Lubricate Outside Of Casing

Remove plug A, remove plug B, reinstall plug A, and connect a supply hose to the fitting on the fluid connector. The lubricant will flow through the dual walled pilot tubes, pilot tube adapter, and out the lubrication ports of the reaming head arms to lubricate the outside of casings.

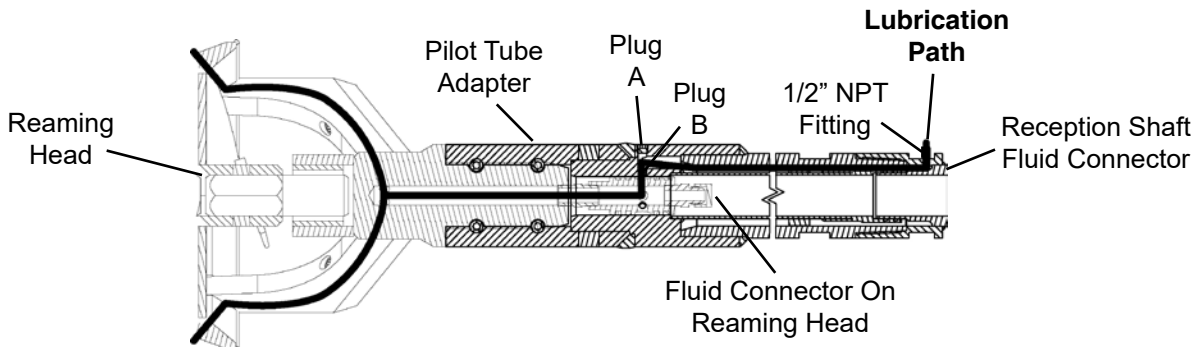

2. To Lubricate Spoils Only

Remove plug A, install plug B, and connect a supply hose to the fitting on the fluid connector. The lubricant will flow through the dual walled pilot tubes and out port A on pilot tube adapter to lubricate the spoils.

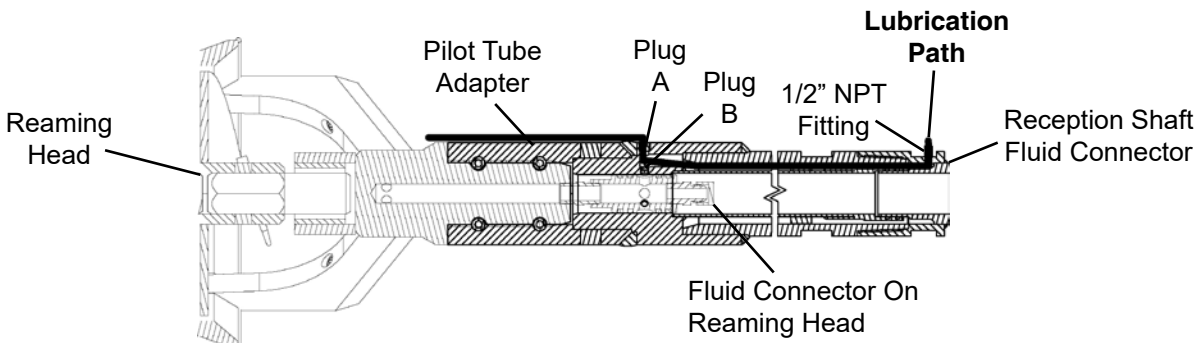

(continued on next page)

3. To Lubricate Outside Of Casings And Spoils

Remove plug A, install plug B, then connect a supply hose to the fitting on the fluid connector. The lubricant will flow through the dual walled pilot tubes and out port A on pilot tube adapter to lubricate the spoils.

Route supply hose through center of reception shaft fluid connector to fluid connector on reaming head. The lubricant will flow through the supply hose into the reaming head fluid connector and out the lubrication ports of the reaming head arms to lubricate the outside of casings.

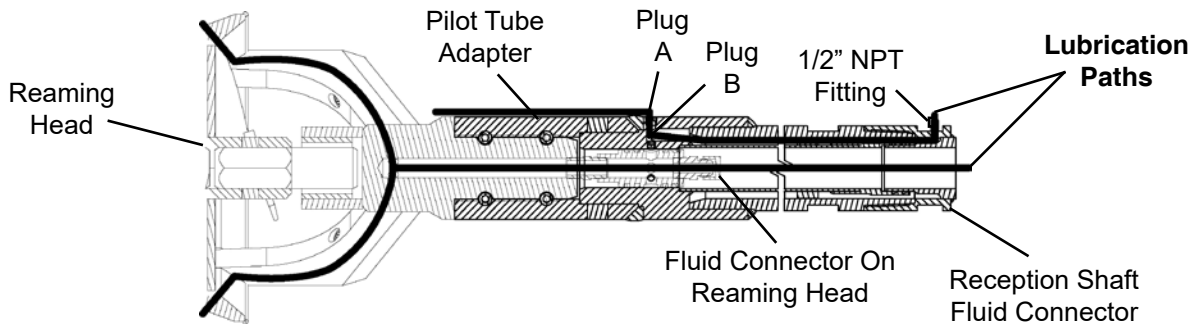

II. Pilot Tube Adapter With Cutter Head Assembly

To Lubricate Spoils

Remove plug A, install plug B, and connect a supply hose to the fitting on the reception shaft fluid connector. The lubricant will flow through the dual walled pilot tubes and out port A on pilot tube adapter to lubricate the spoils.

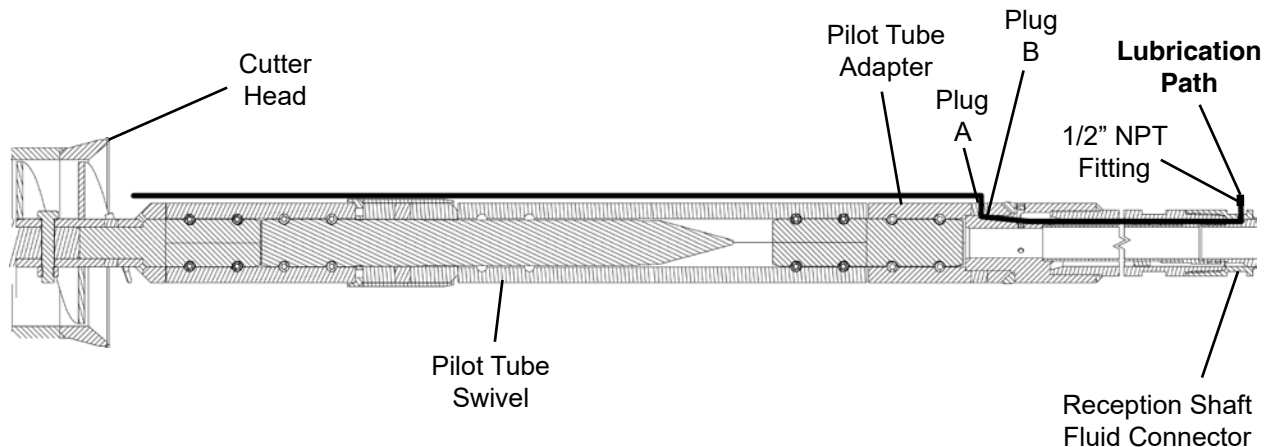

INSTALLING SAFETY CHAIN ASSEMBLY/CASING AUGER PIN TO AUGER & CASING

⚠ WARNING Auger may fall out of casing and cause severe injury or death if casing tips or hits an obstruction.

Properly install safety chain assembly or casing auger pin to augers and casings before lowering into or lifting out of shaft.

Do not stand or walk under a load.

There are two methods of containing the auger in the casing while being lowered into or being raised out of the shafts. Method 1 was an earlier design consisting of the use of a safety chain. Method 2 is the latest design using a pin and clip.

METHOD 1: Safety Chain Assembly

Secure auger to casing with safety chain assembly as follows:

1. Insert pin through shackle and auger shaft. Secure with cotter pin.
2. Adjust position of second shackle on chain link so the pin can be inserted through shackle and auger shaft. Secure with cotter pin.
3. Secure the end of the chain back onto chain with third shackle (A) to keep the chain from hanging loose.
4. Hook the flexible cord to the chain and hoist to take up any chain slack and for ease of reusing the safety chain assembly on the next auger and casing.

(continued on next page)

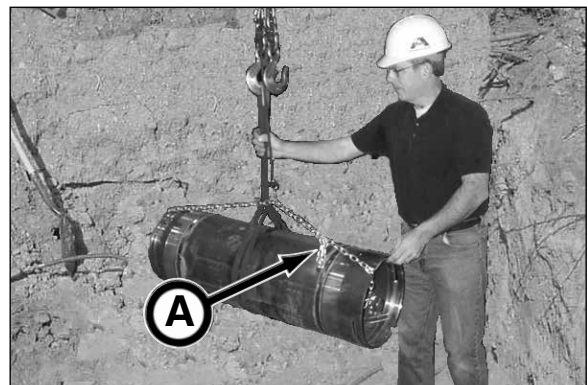

METHOD 2: Pin and Clip

Secure auger to casing with an auger pin and clip as follows:

1. Insert pin (A) through clip retaining slot (B) in casing, through hole in auger stem (C), through clip retaining slot (D) in other side of casing.
2. Secure pin with hardened flat washer (E) and hitch pin clip (F).

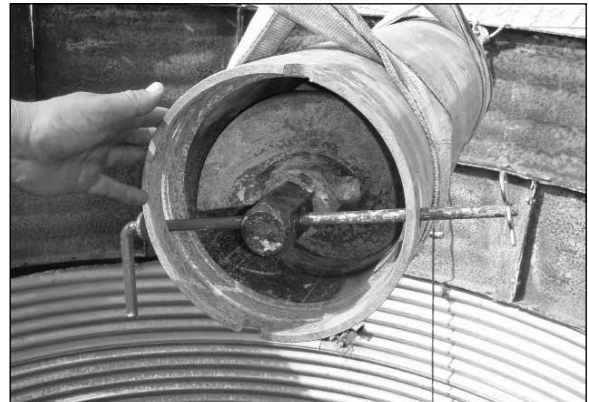
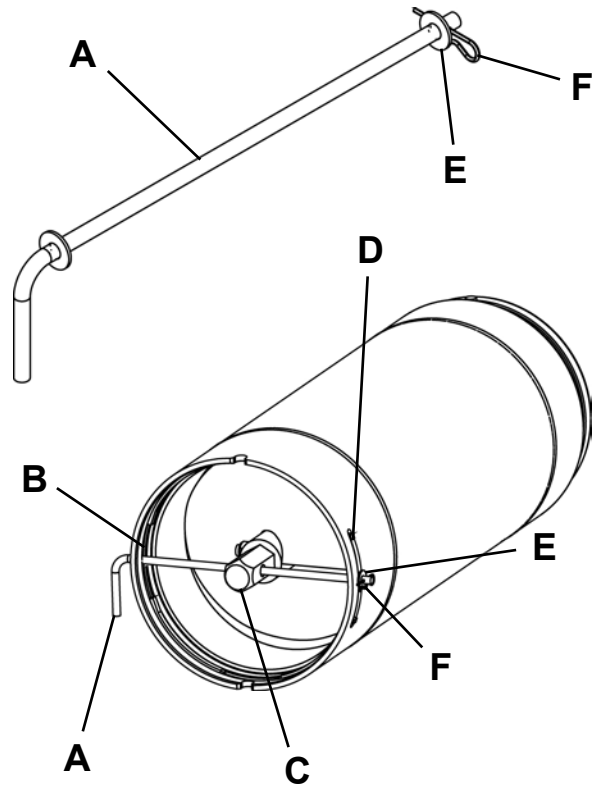

INSTALLING 16" HD INTEGRAL BEARING SWIVEL CUTTER HEAD

The 16" HD Integral Bearing Swivel Cutter Head is the upsizing tool between the pilot tube adapter and the lead thrust casing for hard ground. The cutter head allow pilot tubes to remain stationary while the cutting teeth rotate through ground at a full 17.5" OD cut. The spoils are removed using the standard Akkerman augers and casings to the launch shaft. The cutter head is equipped with fluid ports at the cutter bit reducing cutting torque through lubrication.

REQUIREMENTS

- Must have a minimum of 16 gpm @ 1,000 psi jetting water pressure.
- Set up for 16" HD casings and augers.

There are two methods of installing the integral bearing swivel cutter head:

Method 1: Uses a jetting hose through the center of the pilot tubes.

This method allows the pilot tubes to be removed while continuing to supply jetting water pressure to the swivel cutter head. Though, there must be enough jetting hose and space in the reception shaft to remove three or four pilot tubes before the jetting supply must be shut down.

Method 2: Uses annular space of pilot tubes. This method requires that the jetting water supply must be shut off before removing pilot tubes.

METHOD 1

1. Remove guidance system from shaft and store in protective case.



(continued on next page)

2. With the control pendant power cord removed from the tablet PC assembly control box, insert the connector into the control panel power supply 12VDC connection (A). This connection will supply power to the electronic controls (Jacking Speed, Rotation Pressure, PCH Auger Drive Rotation, and PCH Cutter Drive Rotation) on the control panel.

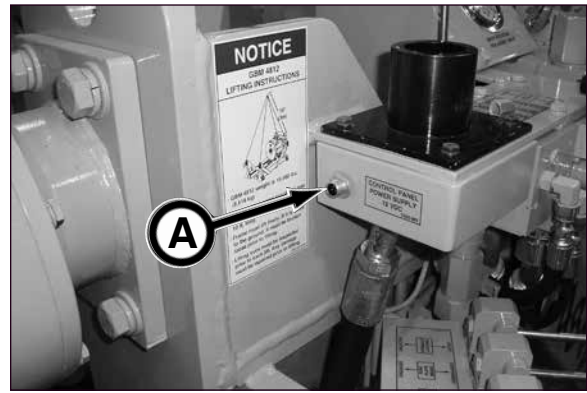

SN 1 - 3

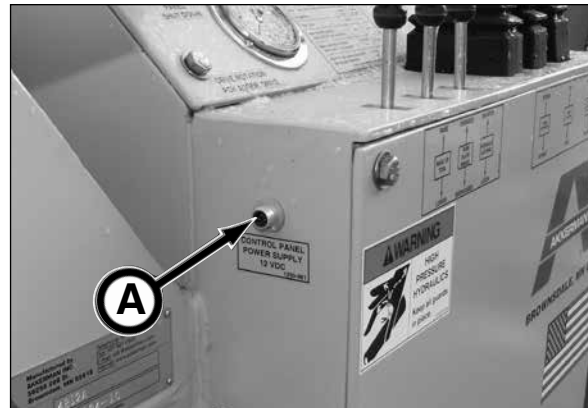

SN 4 & After

3. Start power pack.
4. (P275 SN 1 - 4 Only) With the power pack engine running at 1,500 rpm (100 ton tooling) or full rpm (200 ton tooling), flip the pendant 12V To Monitor & Control Panel switch (B) to the ON position.

NOTICE On the P150Q Power Pack and P275T Power Pack SN 5 and after, the pendant is not equipped with the 12V To Monitor & Control Panel switch (B). As soon as the power pack engine starts, the monitor and control panel switch are automatically turned on.

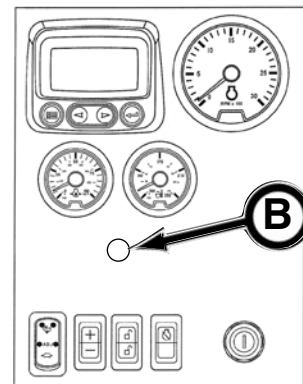

(continued on next page)

5. If not already removed, remove the drive adapter swivel and the swivel support from push plate.

CAUTION The drive swivel adapter weighs approximately 101 lbs. (46 kg). Be careful when handling swivel.



6. Lower the pilot tube adapter and insert the pilot tube adapter hex into the thrust block internal hex.

7. With the last pilot tube locked into the make-up tool, thread the adapter into the pilot tube by rotating the adapter in the CW direction with the drive rotation control, while advancing the push plate with the thrust cylinder control.

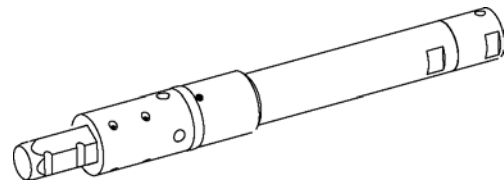

8. Continue to tighten the connection to 500 psi (2,000 ft-lb) torque as shown on the gear box cover pressure gauge.

9. Release make-up tool.

10. Advance adapter into ground until there is enough room to pin the pilot tube adapter to the cutter head assembly.

NOTICE For ease of installing cutter head, you may need to rotate the adapter to be sure the four pin holes are in the vertical (up and down) position (see inset).



11. Remove make-up tool.

12. Move rabbit/push plate to the back of the GBM frame to allow enough room for the dirt bucket and reaming head assembly using the thrust cylinder control.



(continued on next page)

13. Remove hex coupler from pilot tube adapter by removing pins.



14. Mount a roller bracket (A) to shaft wall or make-up tool mount.



15. Remove middle operator platform.



16. Lower dirt bucket into shaft. Be sure to position dirt bucket so the push plate does not contact dirt bucket while jacking. Doing so will cause damage to dirt bucket and jacking frame.

NOTICE There are various sizes of dirt buckets available depending on jacking frame elevation. The larger the dirt bucket, the less it will need to be emptied, resulting in higher productivity.



(continued on next page)

17. In the reception shaft, remove steering head.

a. Remove set screw.



b. Drive out pins.



c. Remove pins.



d. Remove steering head.



(continued on next page)

18. Once the steering head adapter and the pilot tubes reach the reception shaft, each joint must be loosened with the breakout tool.

Hook up the breakout tool as follows:

Clean the areas around the oil ports. Install base end cylinder hose to port A and rod end cylinder hose to port B.

Selector Position:
Port A - Extend
Port B - Retract

⚠ WARNING Electrical shock hazard could cause severe injury or death. Be sure the breakout tool power unit, plug and receptacle (must be three-pronged) are properly grounded and dry before plugging in and during operation.

Plug the breakout tool into 120 VAC outlet. If an extension cord is necessary, you must use a three-prong grounded extension cord.



19. Use the pilot tube scraper to remove mud from steering head adapter (shown) and pilot tubes.



20. Place jaw insert on notches of back pilot tube.



(continued on next page)

21. With the cylinder retracted, slide the breakout tool onto the pilot tube and over the previously installed jaw insert from step 19 as shown.

NOTICE The cylinder side of the breakout tool is deeper than the other side. This allows the breakout tool to slide over both jaw inserts when loosening the pilot tube joints.



22. Slide other jaw insert on notches of the steering head adapter or the front pilot tube.



23. Slide breakout tool over both jaw inserts.

NOTICE You may have to extend or retract the cylinder to line up the jaw insert teeth with the breakout tool gear teeth.



(continued on next page)

24. Move the control lever to port A to extend the cylinder.



25. Extend cylinder by depressing the switch on the remote controller.



NOTICE

The rocker switch on the pump unit can also be used to control the cylinder.



26. Continue to extend the cylinder until the joint is loosened. You should be able to hear and feel a "snap" when the joint is loosened.

27. Release switch on controller.



(continued on next page)

28. Once the joint is loosened, move the control lever to port B.



29. Slightly retract the cylinder until the breakout tool can be slid towards the launch shaft.

30. Remove the front jaw insert.



31. Slide the breakout tool towards the end of the tube and remove the back jaw insert.

32. Slide the breakout tool towards the launch shaft for the next joint removal.



33. Remove the steering adapter. Install a cap on the steering head adapter.



(continued on next page)

NOTICE

To increase productivity, providing there is enough room in the reception shaft, remove three to four pilot tubes before shutting down jetting supply and removing jetting hose from pilot tubes. Pilot tube threads **MUST** be kept clean.

34. Continue to remove pilot tubes (and jetting hose) as they reach the reception shaft. Install a cap on the end of the next pilot tube to be removed to prevent dirt from entering the pilot tube. Place the pilot tubes in the pilot tube racks.



35. Install casing thrust adapter (A) to push plate with (SN1-2) sixteen 3/4 x 1.5 in. bolts and washers. (SN3-4) eight 3/4 x 2 in. bolts and washers or sixteen 3/4 x 2 in. bolts and washers depending on casing thrust adapter.

WARNING

NEVER operate GBM without hinged cover (B) lowered in place as shown. Failure to do so can cause serious personal injury from contact of moving auger.

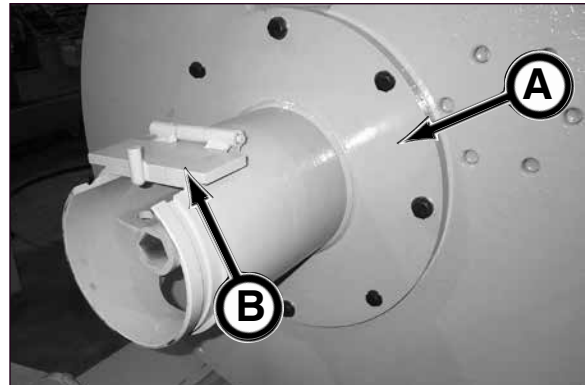

36. Install auger drive adapter into thrust hub.



(continued on next page)

37. Route a supply hose through the pilot tubes and pilot tube adapter from reception shaft to launch shaft to lubricate the cutter bit as follows:

1. Punch a hole in a cap that is less than two inches in diameter.
2. Route a nylon string through the hole and tie a knot large enough so the string will not come back through the cap.
3. At the launch shaft, place the cap/nylon string in the pilot tube and use compressed air to blow the cap/nylon string through the pilot tubes and pilot tube adapter until it reaches the reception shaft.
4. Remove the cap from the string, then secure a 1/4" minimum nylon rope to the nylon string.
5. Pull the nylon string/nylon rope until it reaches the launch shaft.
6. Secure a 5/8" supply hose to the nylon rope and pull the rope until the hose reaches the reception shaft. Be sure female end of hose is at the launch shaft. Remove rope from hose.

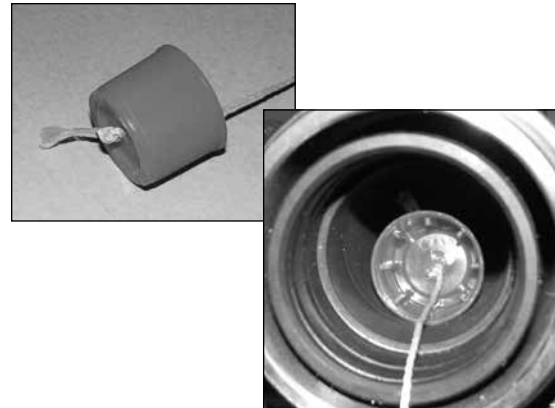

⚠ WARNING Suspended loads may fall and cause severe personal injury or death.

If a hydraulic hose from the boom of a crane or excavator breaks, the boom and load can fall instantly.

Do not stand or walk under a load.

⚠ WARNING Auger may fall out of casing and cause severe injury or death if casing tips or hits an obstruction.

Properly install safety chain assembly to augers and casings before lowering into or lifting out of shaft. Refer to Installing Safety Chain Assembly To Auger & Casing in this section.

Do not stand or walk under a load.

38. Lower cutter head assembly into launch shaft.

NOTICE Use a properly rated pipe tong or nylon strap to handle the cutter head assembly.

(continued on next page)



39. Connect jetting hose to hex shaft connection on swivel cutter head and secure cutter head to pilot tube adapter with four roll pins.

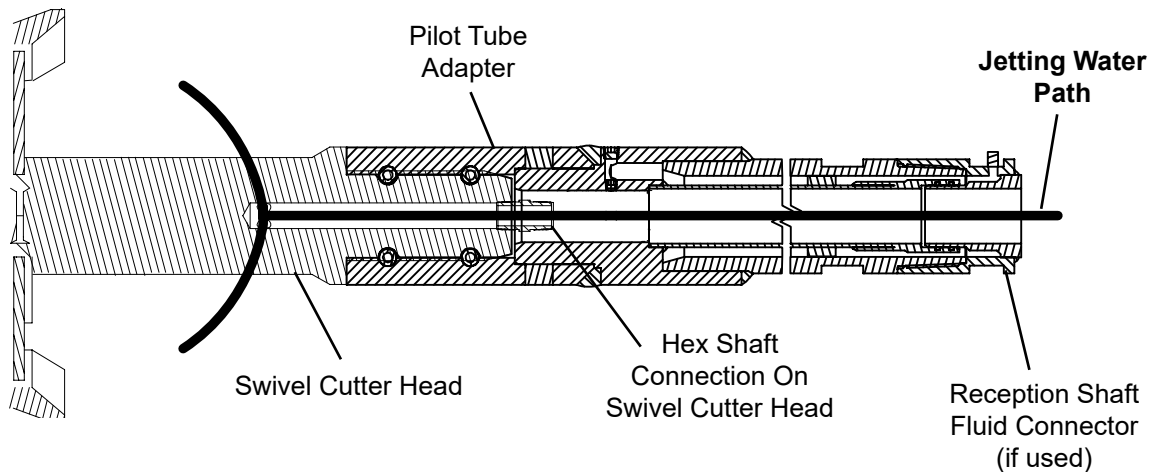

40. Install auger drive adapter onto auger shaft.

NOTICE

For best assembly, align flats on outside of auger shaft adapter and flats on auger drive shaft. Failure to do so will cause premature wear to auger components.

41. Align and engage auger drive adapter with the cutter head auger shaft and the hex opening in thrust block using the drive rotation control and thrust cylinder control.

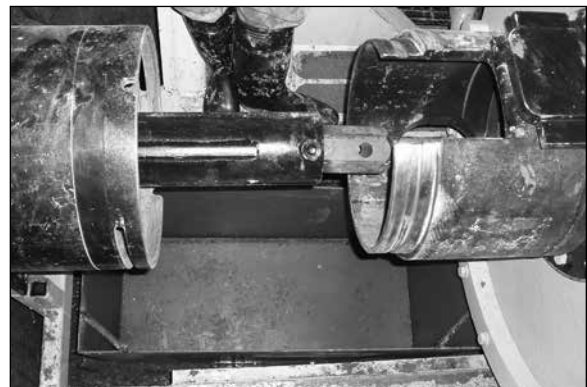

(continued on next page)

42. Using hoist, align notches in cutter head casing with top alignment guide (A) and bottom alignment guide (not shown) on thrust plate.

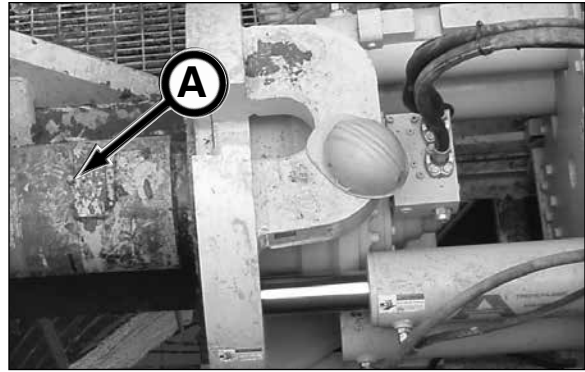

⚠ WARNING Flying sparks and debris from torching operation can cause severe injury. Approved personal protection must be worn while torching opening into shaft.

43. Cut an opening in the shaft large enough for the reaming head, thrust casings, powered cutter head (if used) and product pipe to pass through.



44. Select the jacking speed (B) and rotational pressure (C) switches on the control console as follows:

- a. When using the standard/100 ton thrust casings (2" hex), set jacking speed to Fast and set rotational pressure to Low.

NOTICE NEVER use the standard/100 ton thrust casings (2" hex) in the Slow jacking speed position and the High rotational pressure position. Doing so will damage the thrust casings and augers.

- b. When using the heavy duty/200 ton thrust casings (3" hex), set jacking speed to desired Fast or Slow position, and set rotational pressure to High.

NOTICE Rotation operating range in low pressure is up to 2,000 psi (13.789 MPa) with a maximum pressure of 2,500 psi (17.236 MPa). Rotation operating range in high pressure is up to 4,000 psi (27.579 MPa) with a maximum pressure of 5,000 psi (34.474 MPa).

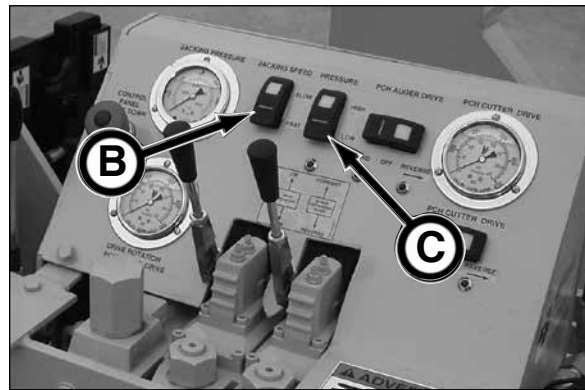

(continued on next page)

⚠ WARNING NEVER open chamber door on casing thrust adapter while auger is rotating. Severe injury may result from contact with rotating auger.



NOTICE

- Jetting to the cutter bit needs to be on at all times while advancing the cutter bit to prevent plugging (as shown) of the cutter head.
- Vary water volume if excessive amount of water to spoils ratio is experienced.

IMPORTANT:

Once cutter head is plugged, it will be difficult, and may require excavation to the cutter head, to clear the plugging. DO NOT PLUG CUTTER HEAD.



45. Test the jetting pump water supply to the cutter bit of the swivel cutter head. The jetting requires 16 gpm @ 1,000 psi.



46. Advance the swivel cutter head with jetting water on, by extending the thrust cylinders with the thrust cylinder control and rotate the augers in the clockwise direction with drive rotation control.
47. Continue to advance the cutter head assembly the full length of the frame.



(continued on next page)

48. Before retracting rabbit/push plate, adjust roller bracket (A) to casing by loosening clamp, slide roller into position, and retighten clamp. The roller will support the casing while the rabbit/push plate is retracted.

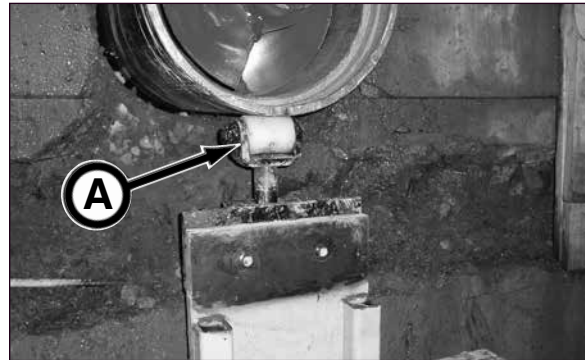

49. Move the rabbit/push plate to the back of the GBM frame using the thrust cylinder control.

⚠ WARNING Moving parts or the mishandling of parts can cause severe personal injury. Handle parts carefully to avoid crushing and pinch point hazards. Properly install safety chain assembly to augers and casings before lowering into or lifting out of shaft.

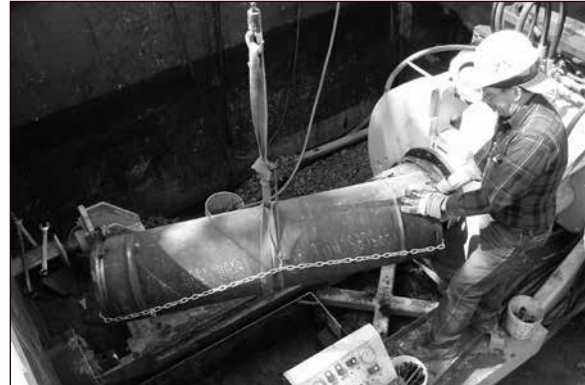

50. Lower thrust casing/auger into launch shaft.

⚠ WARNING Safety glasses must be worn while using power equipment (air tools). Failure to do so could cause severe injury from flying debris.

51. Slide the thrust casing auger onto the end of the reaming head assembly auger shaft.



NOTICE Auger hex connection bolt hole from cutter head assembly must be beyond end of casing to be able to mount bolt in auger joint.

52. With the auger flighting lined up, attach the auger ends with one 3/4 x 6 in. bolt and nylock lock nut. Tighten the nut so the end of the nut is flush with the end of the bolt. Do not overtighten.

53. Advance the casing to the swivel cutter head casing and align with alignment guides in the 12 o'clock (A) and 6 o'clock positions.

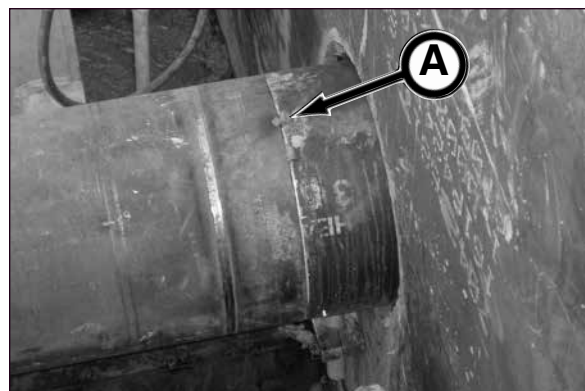

(continued on next page)

54. Install four casing joint keepers at the 2 o'clock, 4 o'clock, 8 o'clock, and 10 o'clock positions to lock the casings together.



55. Remove auger drive adapter (B) from thrust hub and insert onto casing auger shaft.

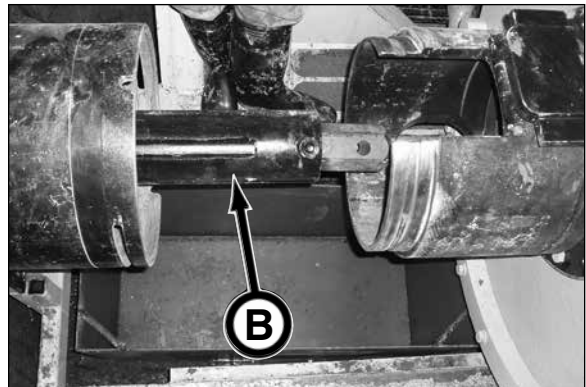

56. Align the auger drive adapter into the thrust hub while aligning the notches in the casings with the alignment guides (C) on thrust adapter using the drive rotation control and thrust cylinder control.

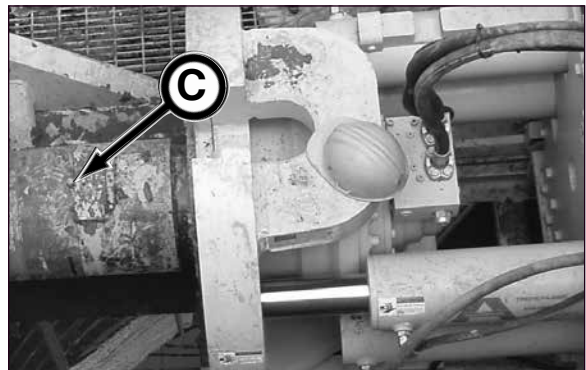

NOTICE BEFORE rotating augers, the casings must be fully engaged with alignment guides on thrust plate. This prevents the casings from rotating with the augers.

57. Start rotating augers with rotation (CW) control and then advance the casing/auger with the thrust cylinder control.

NOTICE Jetting MUST BE ON while advancing casings.

NOTICE With the addition of each section of casing/auger, a section of pilot tube will be removed in the reception shaft. Refer to procedure starting on step 18.

(continued on next page)



NOTICE (5 ft thrust casings only) Once the 5 ft thrust casing is fully advanced, a thrust casing spacer (A) must be placed between the casing thrust adapter and the casing. Then advance the casing with the thrust cylinder control. This step provides additional space for ease of installing the next casing and auger.

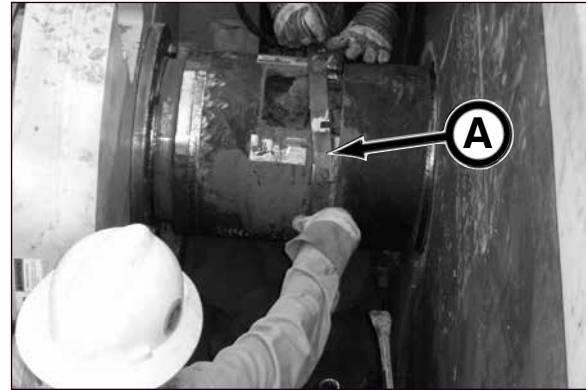

NOTICE Turn off jetting during the process of positioning the next casing/auger in the jacking frame. Failure to do so may cause over-excavation.

58. Periodically empty the dirt bucket.

NOTICE Do not allow dirt bucket to overflow and interfere with machine travel. Keep rails clear of debris.



59. Replace dirt bucket.

NOTICE Be sure dirt bucket will pass between legs on the push plate trolley. Failure to do so will cause damage to frame and dirt bucket during frame operation.



60. Continue to add casings and augers until all pilot tubes and the swivel cutter head are removed from reception shaft.

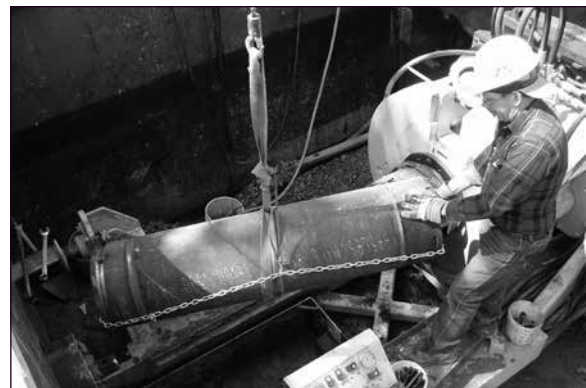

(continued on next page)

NOTICE

Regularly maintain anchor block (A) tension on shaft wall during pilot tube installation by periodically checking screw tension while extending pilot tubes. Securing the frame to the shaft wall will keep the frame properly aligned with the pipe line.

NOTICE

When advancing thrust casings, PCH or product pipe, ALL FOUR thrust block assembly wheels MUST be contacting the jacking frame rails. Failure to do so will result in wheel bearing failure. If this misalignment occurs, the GBM frame must be readjusted so the frame is on the same line and grade as the PCH/product pipe.

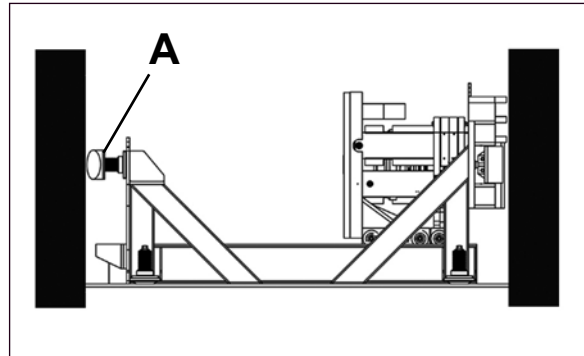

61. Once the pilot tube adapter reaches the reception shaft, remove the last pilot tube with the breakout tool from the pilot tube adapter, cap and plug the pilot tube, and place into pilot tube rack.

NOTICE

The 30" pilot tube is shown.



62. Remove the pilot tube adapter by removing four roll pins from the pilot tube adapter and swivel cutter head connection. Be sure to cap the threaded end of the adapter.



(continued on next page)

⚠ WARNING Contact with rotating auger can result in serious injury. Before operating the auger, be sure all personnel in the launch and reception shafts are clear of any moving parts. DO NOT operate augers when removing auger in the reception shaft.

63. Once the cutter head can be removed from the reception shaft, remove the keepers from the cutter head and lead casing.

NOTICE Using a hoist to keep the cutter head in line with the pipe line, remove bottom keepers first, otherwise the weight of the casing and auger will make it difficult to remove the bottom keepers once the top keepers are removed.



64. Slide the cutter head casing forward to gain access to the auger connection.



65. If your next step is to install the final product pipe, place a block/spacer between auger thrust adapter (A) and auger (B). Push the auger forward with the thrust cylinder control to gain access to the auger connections in the reception shaft for removal.

NOTICE If using a PCH, the auger hex connection must be exposed for connecting the PCH front section to the auger.

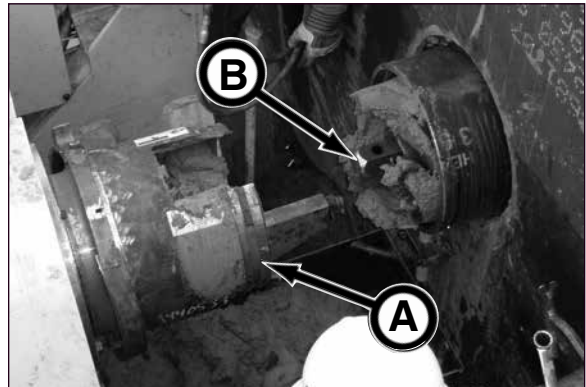

(continued on next page)

66. In the reception shaft, remove the cutter head auger by removing the auger bolt and nut that was installed in the launch shaft (back bolt as shown). Replace auger into the cutter head assembly casing.



⚠ WARNING Auger may fall out of casing and cause severe injury or death if reaming head assembly tips or hits an obstruction.

Properly install safety chain assembly to augers and cutter head/casings BEFORE lowering into or lifting out of shaft.

Do not stand or walk under a load.



67. Install safety chain assembly to auger to secure auger into reaming head assembly. For proper installation of safety chain, refer to Installing Safety Chain Assembly To Auger & Casing in the Operator's Manual.

68. Remove the cutter head assembly from reception shaft.

69. Proceed to "Three Step Method: Installing Product Pipe" in this section, subsection Installing Product Pipe.

OR

If using powered cutter head, proceed to Three Step Method: Installing Powered Cutter Head in this section.



METHOD 2

This method requires that the jetting water pressure must be shut off before removing pilot tubes.

1. Connect fluid connector (A) to hex shaft (B) on swivel cutter head. Be sure o-rings (C) are in good condition (if nicked or cut, replace o-rings) and seated in its proper location. The jetting is supplied through the annular space of the pilot tube.
2. The end adapter must to be capped (D).

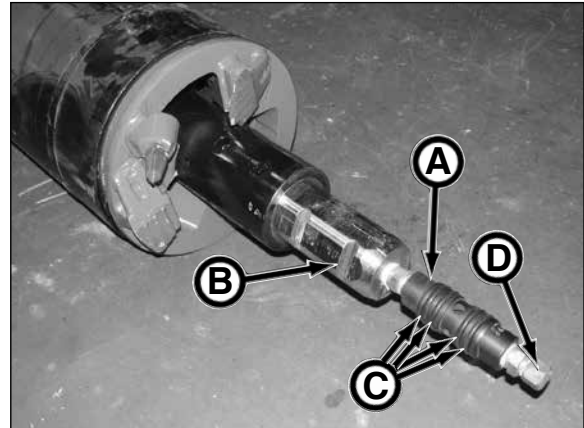

3. Install Swivel Cutter Head to pilot tube adapter with four spiral pins (E).

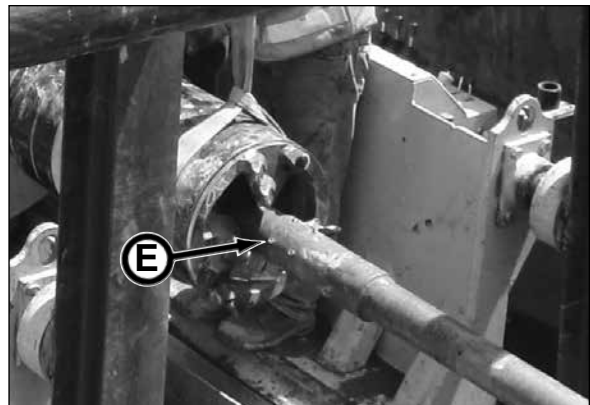

4. The pilot tube adapter must have the 1/8 NPT port (F) open and the 1/4 NPT port (G) plugged.

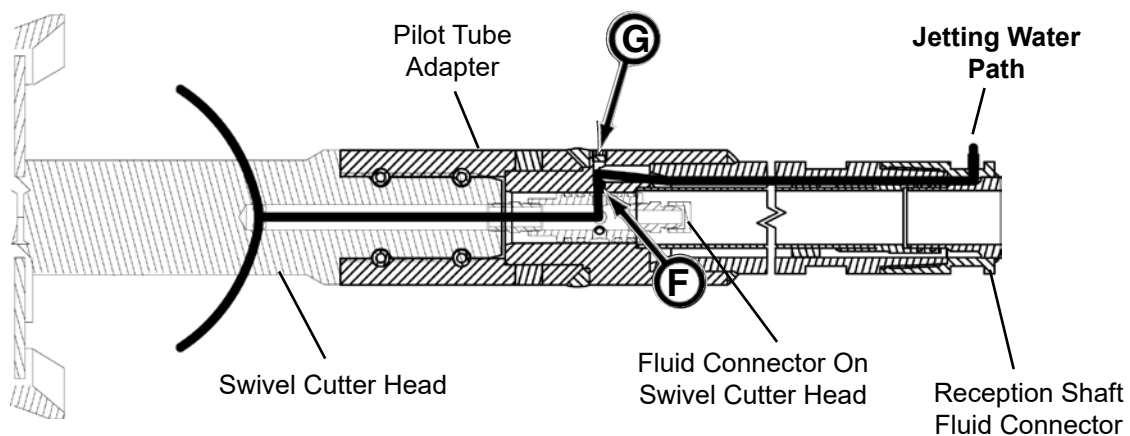

(continued on next page)

5. Install fluid connector on the pilot tube in reception shaft.



6. Connect hose from jetting pump to fluid connector.



7. Test the jetting pump water supply to the cutter bit of the swivel cutter head. The jetting requires 16 gpm @ 1,000 psi.



(continued on next page)

- When removing pilot tubes in reception shaft, stop forward advancement, and turn off jetting supply. Once pilot tube is removed, follow steps 5 through 8.



- Advance swivel cutter head with thrust casings until it reaches the reception shaft. Remove pilot tube adapter from swivel cutter head by removing four spiral pins.



NOTICE

- Jetting to the cutter bit needs to be on at all times while advancing the cutter bit to prevent plugging (as shown) of the cutter head.
- Vary water volume if excessive amount of water to spoils ratio is experienced.

IMPORTANT:

Once cutter head is plugged, it will be difficult, and may require excavation to the cutter head, to clear the plugging. **DO NOT PLUG CUTTER HEAD.**



USING THE LATCHING SYSTEM

When jacking 2 meter product pipe or any pipe longer than 5 feet long, you must use the 4812A latching system for an additional 20" of frame advancement.

1. Before attempting the latching of the jacking frame, be sure rail extension (A) is installed properly.

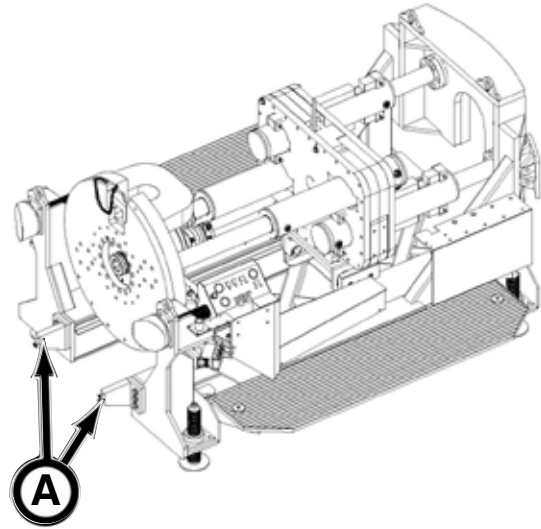

2. Advance pipe completely by extending the thrust cylinders with the thrust cylinder control (B) until cylinders are at full extension.

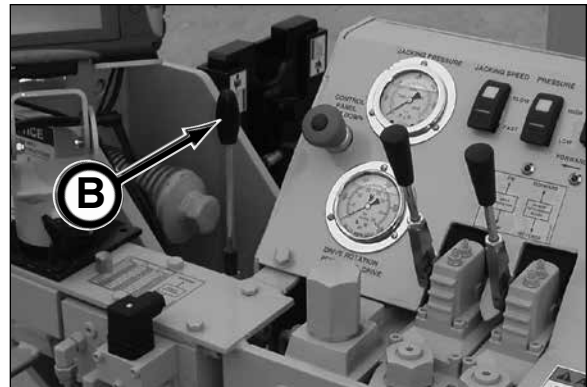

SN 1 -3

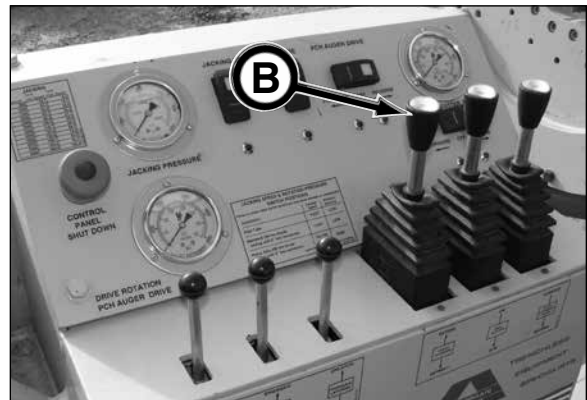

SN 4 & After

(continued on next page)

Operation - Installing Upsizing Tool - Using The Latching System

3. Engage push plate brake using control (C).

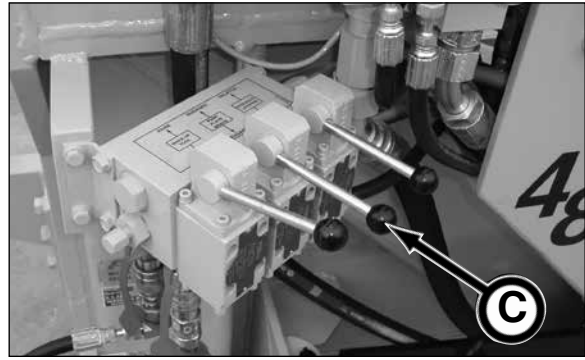

SN 1 - 3

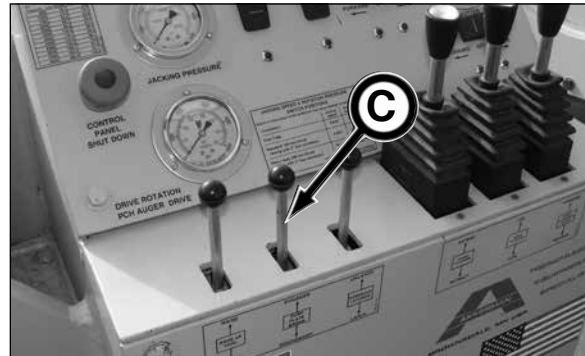

SN 4 & After

4. Unlatch cylinder lock with hydraulic latching control (D) until the latching indicator (E) is fully extended.

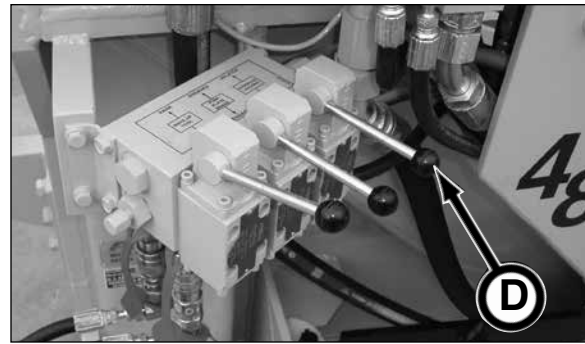

SN 1 - 3

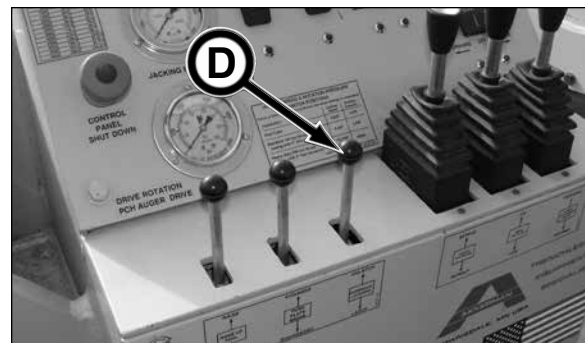

SN 4 & After

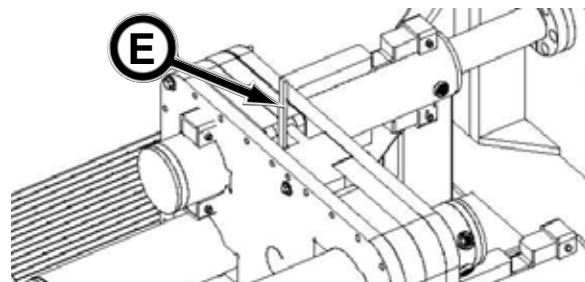

(continued on next page)

5. Retract thrust cylinders until the cylinder stops (A) just contact the rabbit plates (B). Be sure pressure on stop does not exceed 500 psi, otherwise cylinder damage may occur.

NOTICE

BOTH thrust cylinders need to be positioned with cylinder stops contacting rabbit plate before relatching.

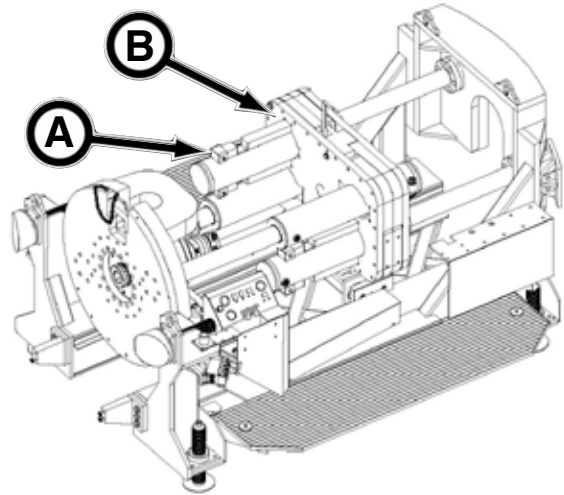

6. Relatch frame with hydraulic latching control. The latching indicator (C) must be fully retracted.
7. Disengage push plate brake.

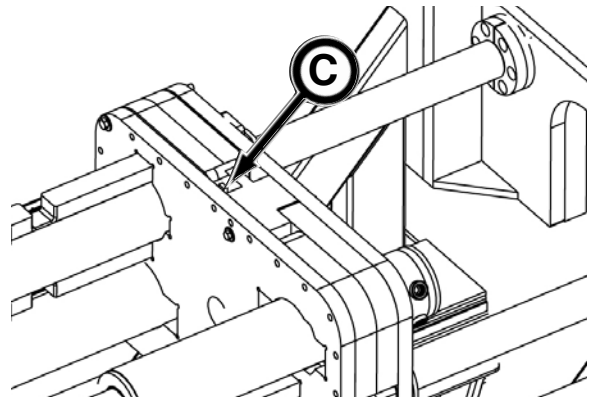

8. Advance thrust casing or pipe completely by extending thrust cylinders.

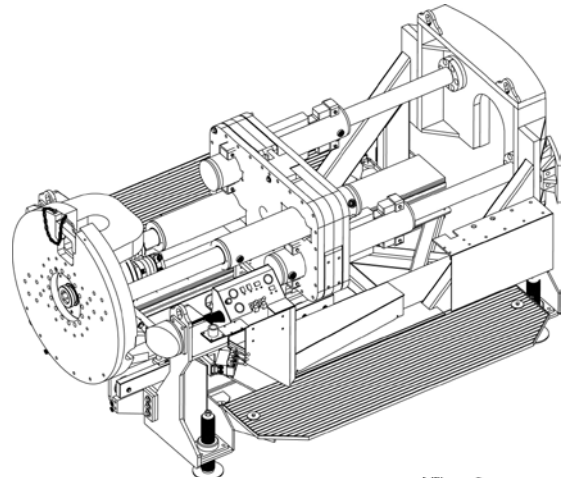

9. Retract cylinders completely.

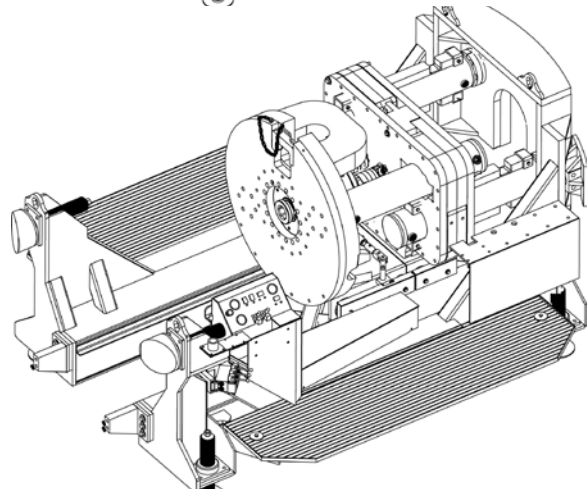

(continued on next page)

10. Engage push plate brake.
11. Unlatch frame with hydraulic latching control until the latching indicator is fully extended.

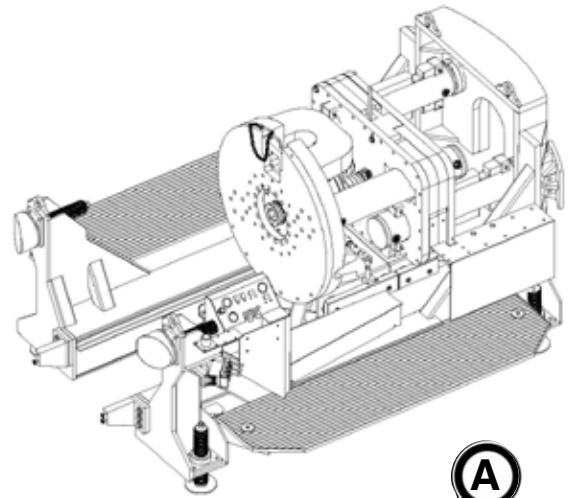

12. Extend thrust cylinders until the cylinder stops (A) just contact the rabbit plates (B). Be sure pressure on stop does not exceed 500 psi, otherwise cylinder damage may occur.

NOTICE

Since the cylinder stops on the back side of the rabbit plates are not visible to the operator, an assistant is necessary to inform the operator when the cylinder stops just contact the rabbit plates. Excessive pressure will damage cylinders.

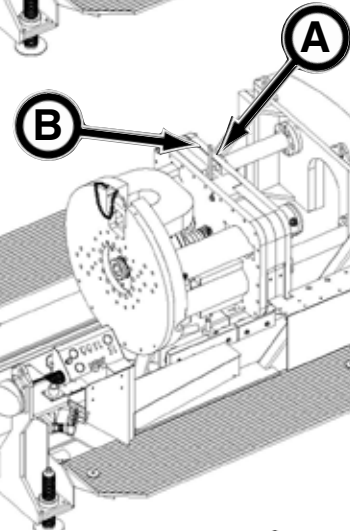

13. Relatch frame until the latching indicator is fully retracted, flush to top of rabbit plates.
14. Disengage push plate brake.

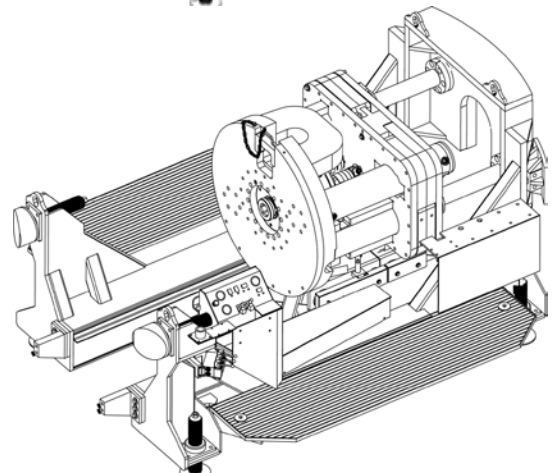

15. Retract thrust cylinders completely.
16. Set your next pipe.

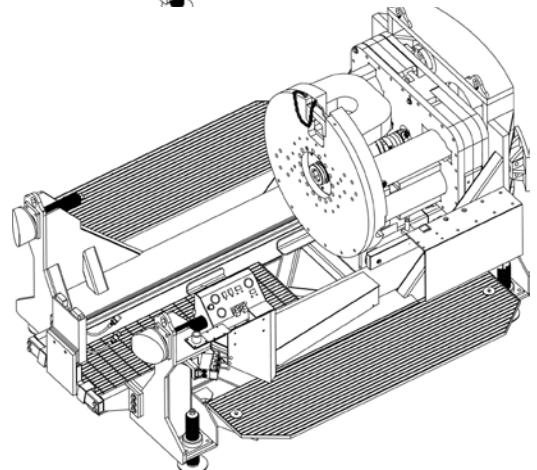

USING THE POWERED CUTTER HEAD

Contractors installing pipe in diameters larger than 20 in. (508 mm) outside diameter now have a more productive choice in their pipeline installation when using the Guided Boring Method; the powered cutter head (PCH).

The powered cutter head proceeds as a three step method; first the pilot tubes are installed by using the Akkerman Guided Boring Machine frame and guidance system. Second, the bore diameter is increased to approximately 11 in. (279 mm) (PCH20-28.5) or 16 in. (406 mm) (PCH36-44) by installing temporary casings and augers. The third step is accomplished by installing the powered cutter head behind the temporary casings and reversing the auger flow direction toward the reception shaft.

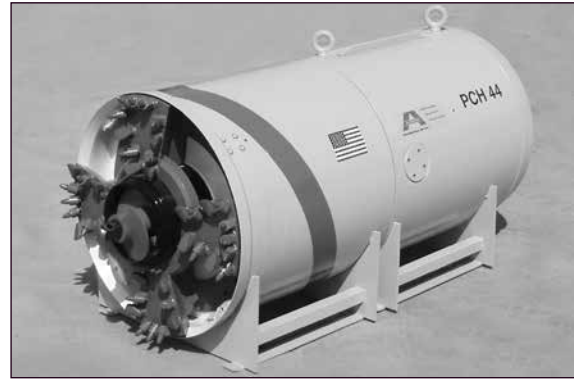

After the powered cutter head is connected to the hydraulic supply of the power unit, it is thrust into the soils and its rotating cutterbit excavates the soil to the final diameter needed for the product pipe. The spoils are then transported through the temporary casings to the reception shaft and new pipe sections are added in the launch shaft as needed. When the powered cutter head reaches the reception shaft the hydraulic supply hoses are disconnected and removed from within the pipeline. The cutter head is then lifted from the reception shaft signaling the completion of the bore.

To install the powered cutter head refer to the following detailed information:

6-35-51
6-35-54
6-35-55
6-35-55
6-35-68

**Use Jetting & Pipe Lubrication With Powered Cutter Head
Soil Stabilization (Chemical Delivery)
Installing Powered Cutter Head - PCH 20 - 22.5 - 28.5
Front Section
Rear Section**

6-35-78
6-35-78
6-35-88

**Installing Powered Cutter Head - PCH 36 - 44
Front Section
Rear Section**

6-35-101

Removing Powered Cutter Head From Reception Shaft

USE JETTING & PIPE LUBRICATION WITH POWERED CUTTER HEAD

When using the Akkerman Powered Cutter Head (PCH), the contractor must plan for jetting, whether or not it is needed for the project. If a "change of conditions" occurs, and the PCH is not plumbed for jetting or is not being used, in many instances, the PCH will become plugged. In addition to using jetting with the PCH, lubricating the product pipe should also be used to reduce jacking pressure. Akkerman highly recommends to always use jetting and lubrication on a PCH drive. Akkerman highly recommends to ALWAYS start with jetting since without jetting, a clogged head and casings may result at the launch. Keep in mind that too much water in spoils reduces jetting psi.

What is Jetting?

• Jetting consists of water or a water / polymer mixture. Baroid's EZ MUD®, a water soluble polymer or equivalent can be used. Ask your polymer supplier for the proper jetting mixture based on the Geotech report for your project.

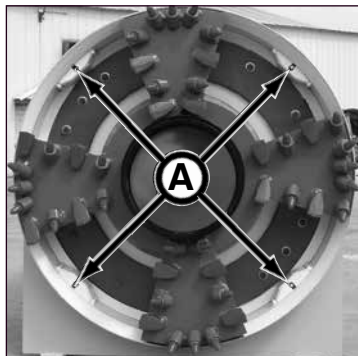

Why use Jetting?

- The three or four jetting nozzles (A) on the PCH reduces cutter head torque requirements by lubricating the metal parts along with the spoils to reduce or eliminate the clogging of the head or cutter bit.
- Torque of the auger drive is also reduced since the material flows more freely due to less friction on the metal parts.
- The use of jetting also cleans the cutter bit to improve the cutter bit performance.



(continued on next page)

Jetting Supply Requirements

The jetting supply should pump:	Minimum	Maximum
PCH20-28.5:	5 gpm @ 1,000 psi (19 lpm @ 6,895 kPa)	7 gpm @ 1,500 psi. (26.5 lpm @ 10.342 MPa)
PCH36-44:	8 gpm @ 1,000 psi (30 lpm @ 6,895 kPa)	10 gpm @ 1,500 psi. (38 lpm @ 10.342 MPa)

The maximum operating pressure is 2,500 psi (17.24 MPa).

Jetting Hookup

(PCH20 - 28.5) Install jetting hose (A) (not shown on model PCH 20) to jetting inlet port (B). When launching front section, install hoses to jetting supply source. Once front section is launched, disconnect jetting hose from jetting supply. Route jetting hose through rear section into jetting filter (C) and then connect jetting filter outlet hose (D) to supply source. Install additional supply hoses as needed.

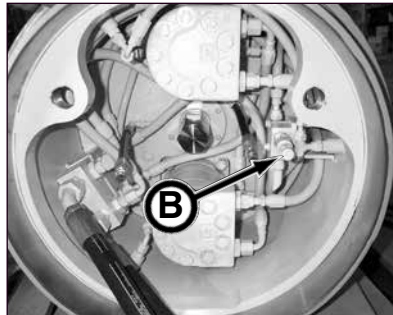

Model PCH 20 - Jetting Port

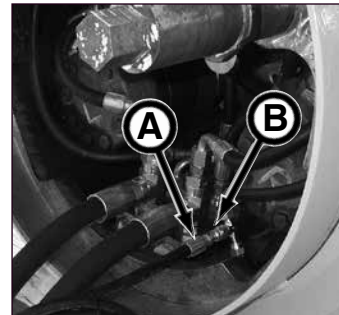

Model PCH 22.5 - Jetting Port

(PCH36-44) When launching front section, install hoses to jetting supply source. Once front section is launched, disconnect jetting hose from jetting supply. Route jetting hose through rear section into jetting filter (C) and then connect jetting filter outlet hose (D) to supply source. Install additional supply hoses as needed.

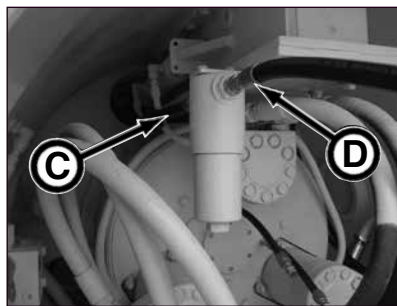

Model PCH44 - Jetting Connections

Using Jetting

- With jetting properly installed on PCH and jetting supply pump, turn valve (E) to ON position for jetting and turn return valve (F) to OFF position.
- The amount of jetting depends on ground conditions. If your spoils consist of a slurry substance, the amount of jetting should be reduced by lowering water psi.
- Only use jetting when advancing pipe to prevent over excavating.
- When shutting down the jetting, be sure to turn return valve (G) to ON position, and then turn jetting valve (H) to OFF position to prevent pressure buildup in jetting hoses.

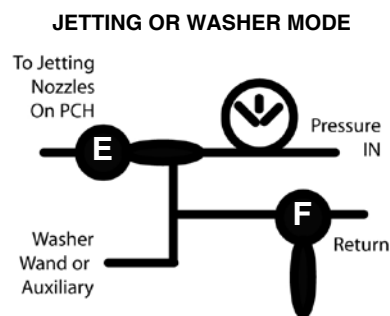
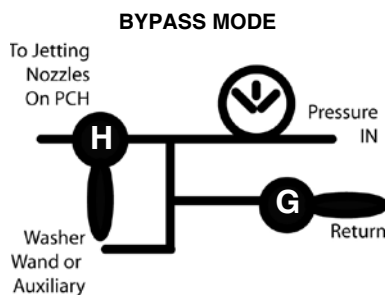

(continued on next page)

Lubricating Product Pipe

- Lubricating the product pipe around the outside of the pipe has proven to be very effective in reducing the friction between the product pipe and the soil that surrounds it. This lubrication results in a significant decrease in thrust. There are three ports (A) in the rear section of the PCH.
- Lubrication type or mixture is based on soil conditions, consistency, clay, sand, etc. Your polymer supplier can help you with the proper lubrication mixture based on your Geotech report for the project.
- Do not lubricate the first 2-3 pipe so there is a seal between pipe and shaft. Otherwise, lubricant may be pumped into launch shaft.
- Only lubricate while advancing pipe to prevent the lubricant from flowing into launch shaft or into the cutter face causing plugging, resulting in decreased productivity.
- Install supply source to lubrication inlet port or hose (B) on back of rear section.
- Lubrication pump maximum operating pressure rating: 10 gpm @ 500 psi (38 lpm @ 3,447 kPa).

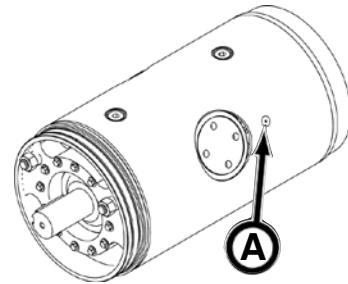

Lubrication Ports

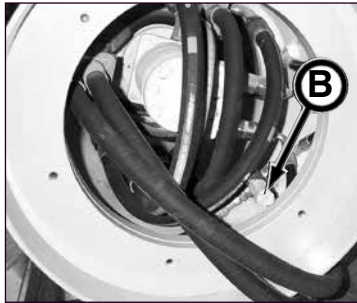

Model PCH 20 - Lubrication Inlet Port

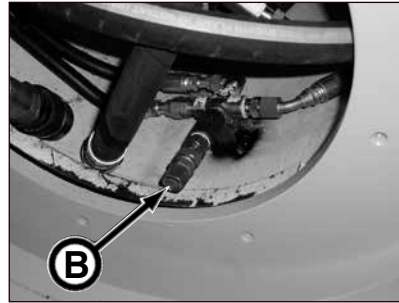

Model PCH 22.5 - Lubrication Inlet Port

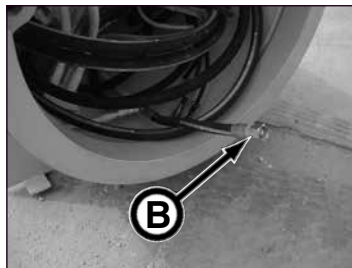

Model PCH36/44 - Lubrication Inlet Hose

SOIL STABILIZATION (CHEMICAL DELIVERY)

A chemical delivery connection (A) is installed on the Powered Cutter Heads to allow chemicals or polymers to be added into the soil to control soil settlement or erosion thus preventing over-excavation.

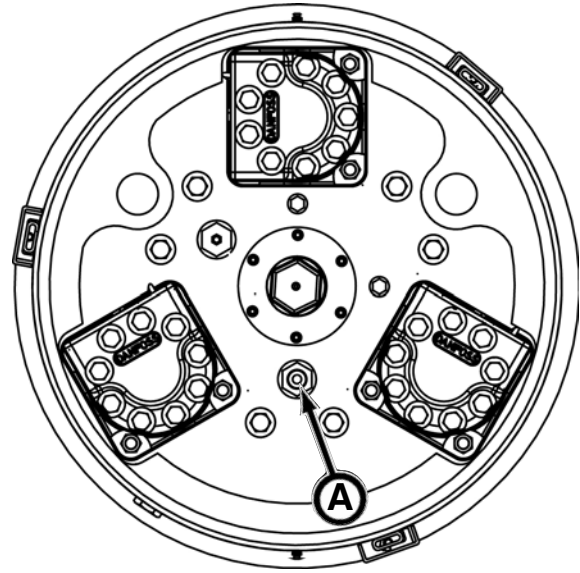

Pumping the chemical or polymer mixture into the chemical delivery connection, will discharge the mixture out of the chemical discharge port (B) into the auger casing cavity of the powered cutter head to help stabilize the soil.

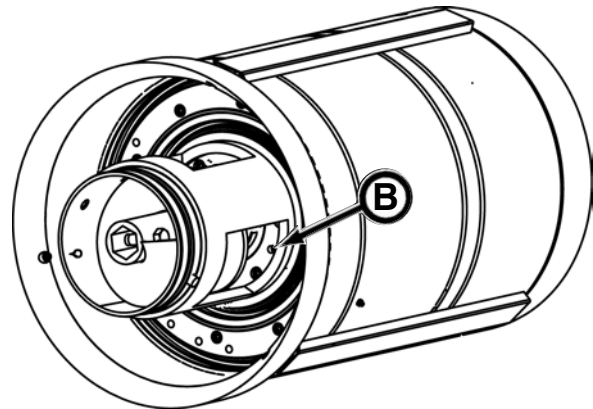

NOTICE

Be sure to connect a 5/8" or 1" hose (not included) (hose must exceed the pump flow and pressure rating specifications) to the chemical delivery connection (#8 MFFOR) prior to launching the PCH rear section, otherwise chemical stabilization via the PCH will not be possible.

Also, if using the chemical delivery feature, keep in mind that if the discharge port is not used at the beginning of the drive and throughout the bore, the discharge port may become plugged.

Consult your local polymer supplier or other soil specialist to help you determine the proper chemical or polymer mixture based on your Geotech report for the project.

INSTALLING POWERED CUTTER HEAD 20, 22.5 & 28.5 - FRONT SECTION

NOTICE

When using the Powered Cutter Head (PCH), the contractor **MUST** plan for jetting and lubrication, whether or not it is needed for the project. If a “change of conditions” occurs, and the PCH is not plumbed for jetting/lubrication or is not being used, in many instances, the PCH will become plugged. The use of jetting and lubrication helps reduce jacking pressures. For more information, refer to Using Powered Cutter Head Jetting & Lubrication in this section. Akkerman highly recommends to always use jetting and lubrication on a PCH drive.

1. Once the reaming head assembly reaches the reception shaft, lower winged casing/auger into launch shaft.

NOTICE

The winged casing/auger is used to prevent rotation of the casing when attached to PCH. If there is rotation, operate the cutter head in the opposite direction to maintain the original casing position. Operate the cutter head direction as needed to maintain the original casing position.

NOTICE

As the reaming head and casings are advanced into the reception shaft, the reaming head assembly and casings must be supported to maintain alignment. Failure to do so will deteriorate the bottom of the bore hole resulting in poor grade alignment.

NOTICE

To reduce rotational pressures during launch of PCH, rotate augers to remove spoils contained in augers and casings to launch or reception shaft.

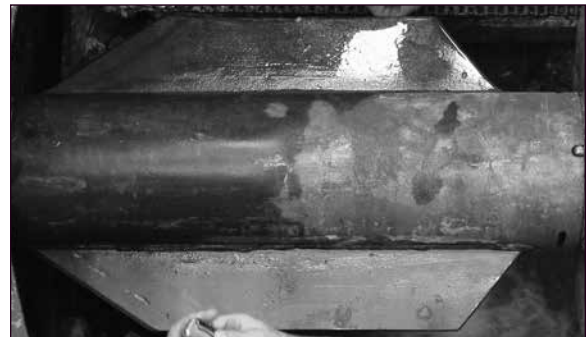

2. Slide the winged casing auger onto the end of the front auger shaft.

⚠ WARNING

Safety glasses must be worn while using power equipment (air tools). Failure to do so could cause severe injury from flying debris.

3. With the auger flighting lined up, attach the auger ends with one 3/4 x 4 in. bolt and nylock lock nut. Tighten the nut so the end of the nut is flush with the end of the bolt. Do not overtighten.



(continued on next page)

4. Advance the winged casing to the front casing and align with alignment guides in the 12 o'clock (A) and 6 o'clock positions.

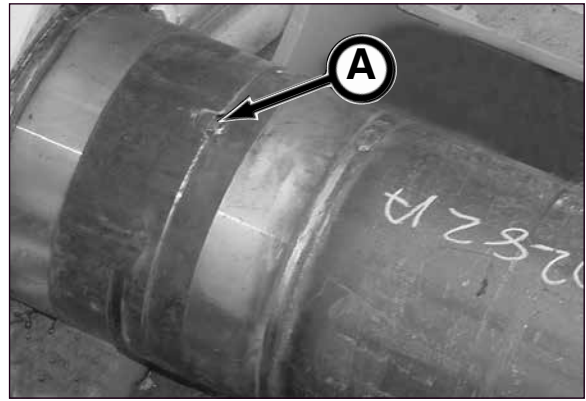

5. Install four casing joint keepers at the 2 o'clock, 4 o'clock, 8 o'clock, and 10 o'clock positions to lock the casings together.



6. Remove auger drive adapter (B) from thrust block and insert onto casing auger shaft.
7. Align the auger drive adapter into thrust block hub (C) while aligning the notches in the winged casing with the alignment guides on casing thrust adapter using the drive rotation control and thrust cylinder control.

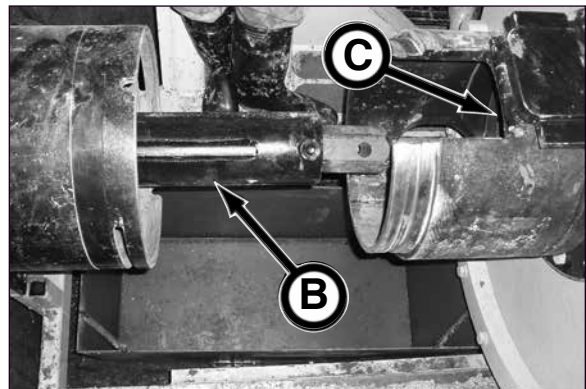

8. Be sure the jacking speed switch (D) is in the FAST position and the rotational pressure switch (E) in LOW position. Failure to place the switches in these positions will cause damage to thrust casings and augers.

(continued on next page)

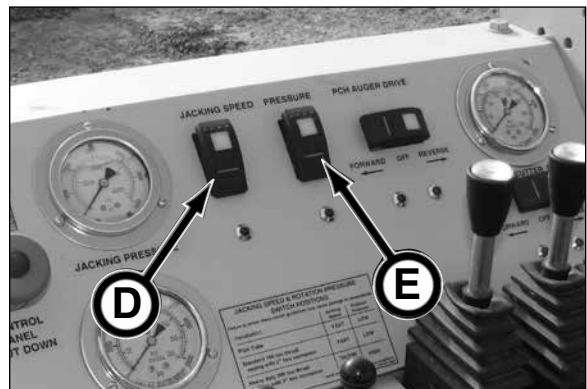

NOTICE

BEFORE advancing, the casings must be fully engaged with alignment guides on casing thrust adapter. This prevents the casings from rotating with the augers.

9. Advance the winged casing/auger with the thrust cylinder control and as far forward as possible to allow enough room for the powered cutter head front section.



NOTICE

Be sure the winged casing auger shaft is exposed 4-6 inches for ease of connecting auger shaft to powered cutter head auger shaft.



10. Remove casing thrust adapter (A) from the GBM frame.

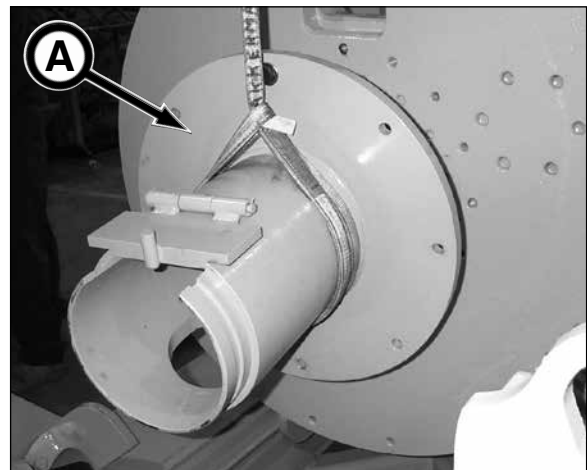

(continued on next page)

11. Once the reaming head assembly can be removed from the reception shaft, remove the keepers from the reaming head assembly and lead casing.



NOTICE

Using a hoist to keep the reaming head in line with the pipe line, remove bottom keepers first, otherwise the weight of the casing and auger will make it difficult to remove the bottom keepers once the top keepers are removed.



12. Slide the reaming head assembly casing forward to gain access to the auger connection.



13. Install powered cutter head thrust plate extension (A) to thrust plate with eight 3/4-10 x 2 in. bolts and flat washers.

NOTICE

If an increaser kit was added on your PCH, use the original base machine size thrust plate extension for jacking the front section. When jacking the PCH rear section, the original size thrust plate must be replaced with the increaser kit sized thrust plate.

14. Install pipe thrust adapter (B) to plate extension with 3/4-10 x 3 in bolts and flat washers.

NOTICE

Longer pipe joints may require a thicker pipe support and longer bolt lengths.

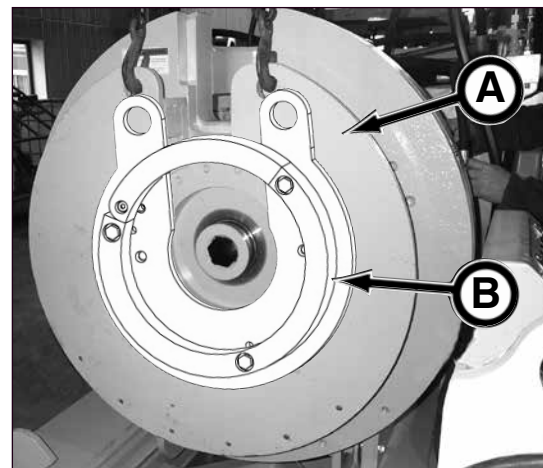

(continued on next page)

15. Remove 8" hex connection from winged casing auger. If the hex connection bolt cannot be removed, pull auger back far enough (approximately 4 inches) for the bolt to clear casing.



⚠ WARNING Suspended loads may fall and cause severe personal injury or death.

If a hydraulic hose breaks from the boom of a crane/excavator, or the lifting support fails, the boom and/or load can fall instantly.

Do not stand or walk under a suspended load.



⚠ WARNING DO NOT tip PCH while lowering into launch shaft to prevent PCH from slipping out of lifting straps (if used). Otherwise, severe injury or death may result from falling PCH.

- 16a. Use a properly rated lifting strap for the weight of the PCH. Refer to section 12, Specifications for the weight of the PCH front section.
- 16b. Lower powered cutter head (PCH) into launch shaft.



NOTICE When installing PCH, be sure it is positioned so the two alignment pin holes (A) are above center line indicating this is the top position. Positioning PCH in upside down position will result in a gear case oil leak in the rear section of the PCH.

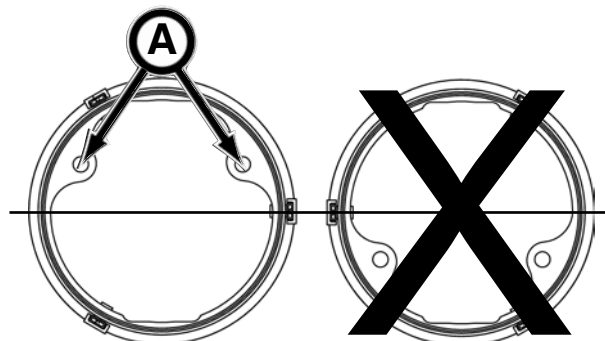

Correct PCH Position

Incorrect PCH Position

(continued on next page)

17. If not already installed, connect jetting hose to PCH.

1. Install jetting hose (A) to jetting inlet port (B).
2. When launching front section, install hose to jetting supply source.

NOTICE Once front section is launched, disconnect jetting hose from jetting supply and route jetting hose through rear section, connect to water filter and then to supply source. Add additional hoses as needed.

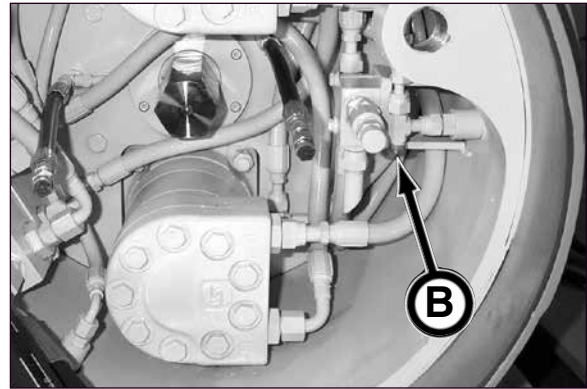

PCH 20

18. Test jetting nozzles for proper operation and be sure there are no leaks.

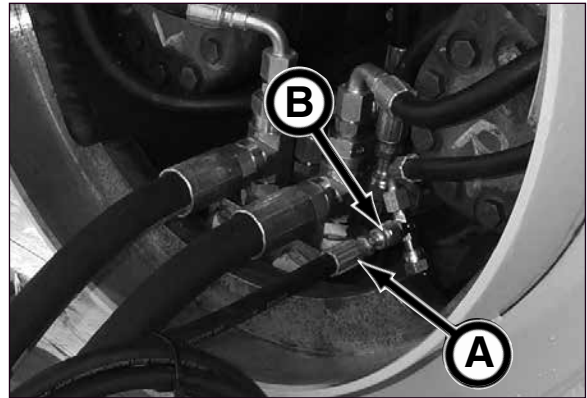

PCH 22.5

19. Advance thrust plate so the bell end of the PCH is aligned and flush with PCH thrust plate on GBM frame.



20. Be sure spacer auger (C) is in place on the PCH hex shaft before lining up the PCH auger with the winged casing auger flighting (D).

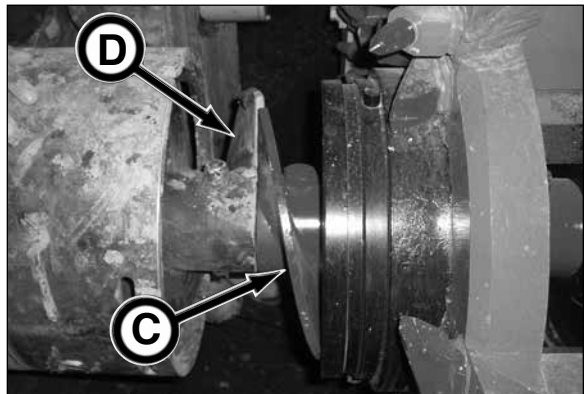

(continued on next page)

⚠ WARNING Safety glasses must be worn while using power equipment (air tools). Failure to do so could cause severe injury from flying debris.

21. With the auger flighting lined up, attach the auger ends with one 3/4 x 4 in. bolt and nylock lock nut. Tighten the nut so the end of the nut is flush with the end of the bolt. Do not overtighten.



22. Advance PCH auger casing to winged casing by aligning notches on winged casing with top and bottom alignment guides (A) on PCH auger casing.

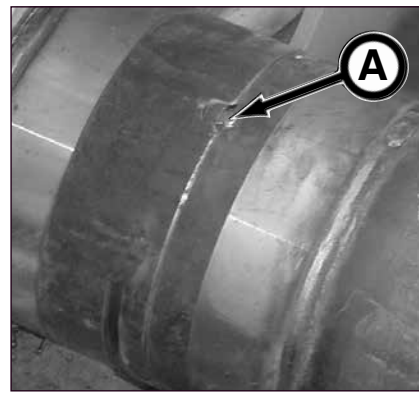

23. Install four casing joint keepers at the 2 o'clock, 4 o'clock, 8 o'clock, and 10 o'clock positions to lock the casings together.



(continued on next page)

24. With crane (or other lifting device) supporting the PCH, retract the GBM thrust plate and install the drive extension (A) into the PCH and connect to auger drive adapter (B) in GBM thrust plate.

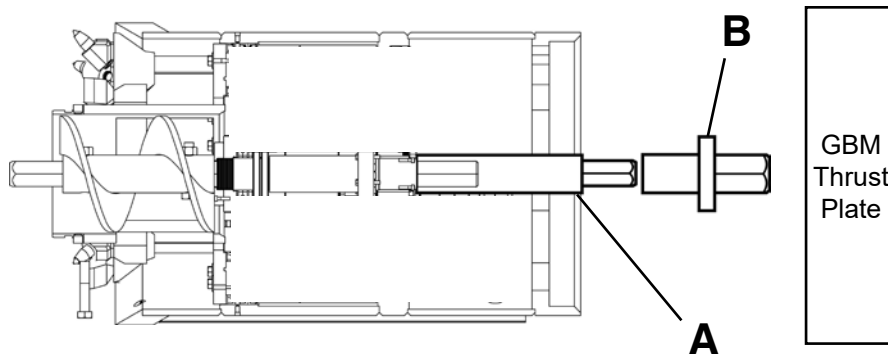
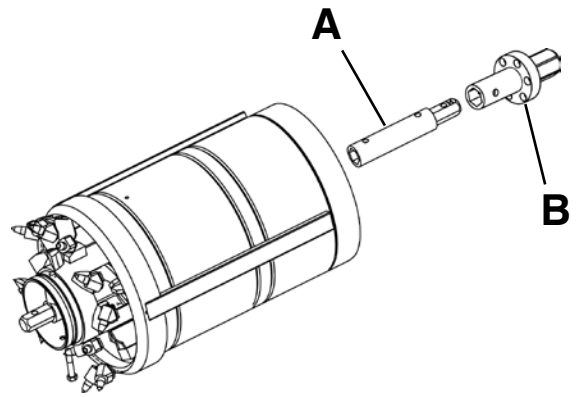

NOTICE

When advancing PCH or product pipe, ALL FOUR thrust block assembly wheels MUST be contacting the jacking frame rails. Failure to do so will result in wheel bearing failure. If this misalignment occurs, the GBM frame must be readjusted so the frame is on the same line and grade as the PCH/product pipe.

25. Advance thrust block with thrust cylinder control so the bell end of the PCH is aligned and flush with PCH thrust plate on GBM frame.



NOTICE

Be sure auger drive shaft is aligned with thrust plate by aligning flats on outside of auger shaft adapter and flats on auger drive shaft. Failure to do so will cause premature wear to auger components.

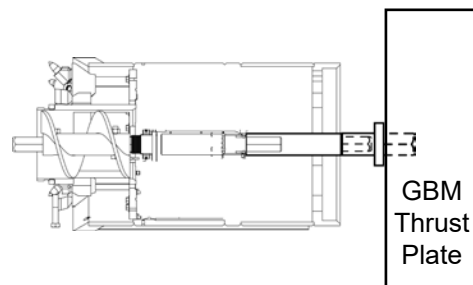

(continued on next page)

26. Disconnect lifting straps from PCH and remove from launch shaft.
27. Lower casing support roller so it does not interfere with the PCH overcut.

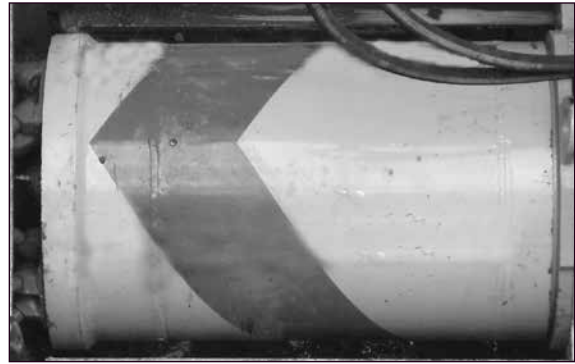

28. Connect two jumper hoses (A) to the two 3/4" hose quick disconnects from PCH to the quick-disconnects on GBM. These are the pressure and return hoses for the cutter head drive.

NOTICE The jumper hoses are used only while launching the front and rear PCH sections.

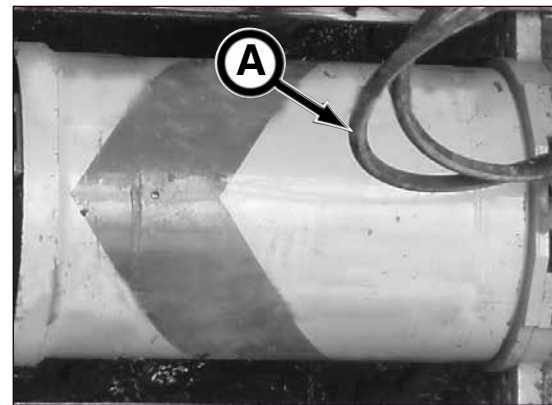

NOTICE As the reaming head and casings are advanced into the reception shaft, the reaming head assembly and casings must be supported to maintain alignment. Failure to do so will deteriorate the bottom of the bore hole resulting in poor grade alignment.

29. In the reception shaft, remove the reaming head auger by removing the auger bolt and nut that was installed in the launch shaft (back bolt as shown). Replace auger into the reaming head assembly casing.



(continued on next page)

⚠ WARNING Auger may fall out of casing and cause severe injury or death if reaming head assembly tips or hits an obstruction.

Properly install safety chain assembly to augers and reaming head/casings BEFORE lowering into or lifting out of shaft.

Do not stand or walk under a load.



30. Install safety chain assembly or auger pin to auger to secure auger into reaming head assembly. For proper installation of safety chain or auger pin, refer to Installing Safety Chain Assembly/Casing Auger Pin To Auger & Casing in this section.

31. Remove the reaming head assembly from reception shaft.



⚠ WARNING Contact with rotating auger or cutter head can result in serious injury. Before operating the cutter head and auger, be sure the personnel in the launch and reception shafts are clear of any moving parts.



(continued on next page)

32. Flip the PCH cutter head switch (A) to Forward and check for proper rotation and operation, and be sure there are no leaks. Then flip switch to Reverse and check for proper rotation and operation.

NOTICE

The Control Panel Shutdown control (B) must be pulled out for the PCH cutter head control to function. Be sure power supply cord from pendant is connected to Control Panel Power Supply 12VDC connection on side of control panel.

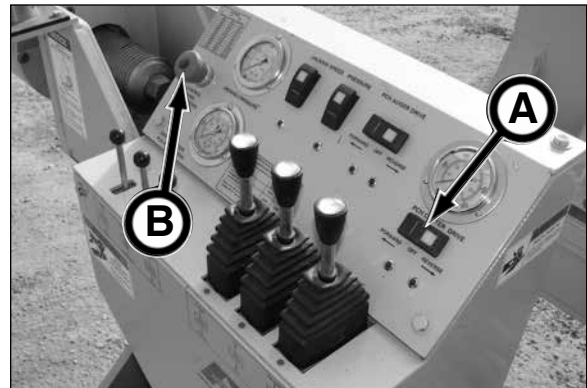

33. Check cutter bit speed. The cutter bit speed should be approximately 15 rpm. When using the P275T Power Pack with the PCH 20, PCH 22.5 or the PCH 28.5, the engine speed must be reduced to 1500 rpm to prevent over speeding of the PCH motors. The P275T pump flow will exceed the input flow requirements when operating the engine above 1500 rpm. Running engine faster than 1500 rpm may result in premature wear to cutter bits and hydraulic components.



(continued on next page)

34. Rotate the cutter head with PCH cutter head switch (A) in forward position, turn on jetting at supply source, and rotate the auger counterclockwise (CCW) with the drive rotation control (B) so the spoils are removed to reception shaft.

Using a communication device between the launch and reception shafts, contact the personnel in reception shaft to confirm that the auger is rotating in the clockwise direction (looking at auger towards launch shaft) and that the spoils are going into the reception shaft.

35. Set the rotation pressure switch (C) to Low and the jacking speed switch (D) to Fast or Slow depending upon ground conditions/product pipe. BE SURE TO NOT EXCEED PIPE RATING! Doing so will break product pipe.
36. Start jacking (advancing) the PCH by extending the GBM thrust cylinders using the thrust cylinder control (E) while rotating the PCH cutter head with switch (A) in forward position and drive rotation control (B) in counterclockwise (CCW) position.

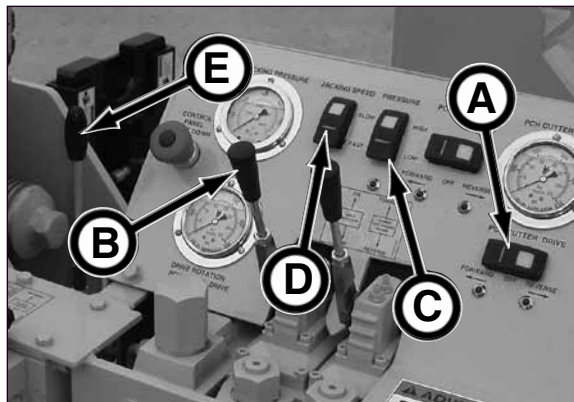

SN 1-3

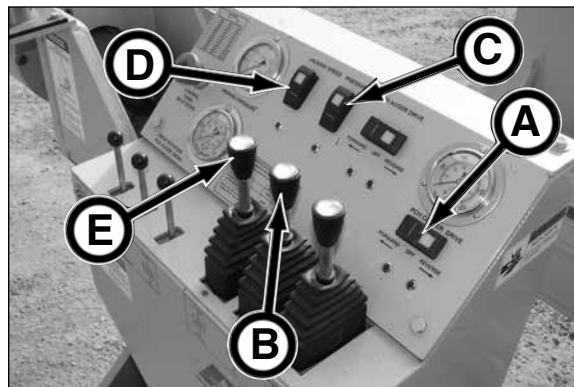

SN 4 & After

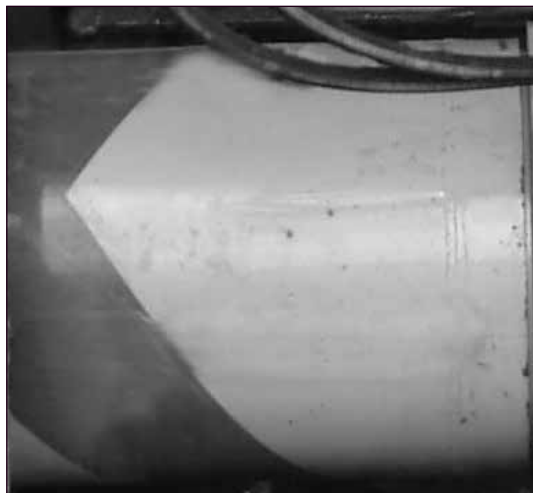

37. While jacking the PCH, monitor the auger drive rotation pressure with gauge (F), the cutter head operating pressure with gauge (G), and the jacking pressure with gauge (H) to determine advance rate.

NOTICE When using the jacking frame auger drive with the 2" hex augers, the maximum operating pressure is 2,500 psi (Low pressure) only during the launch of the PCH front section. Failure to follow these guidelines will result in auger damage.

Normal operating pressure:
 Auger - 1,000 - 2,000 psi
 (6.895 MPa - 13.790 MPa)

Cutter head - 2,000 to 4,000 psi
 (13.790 - 27.579 MPa)

(continued on next page)

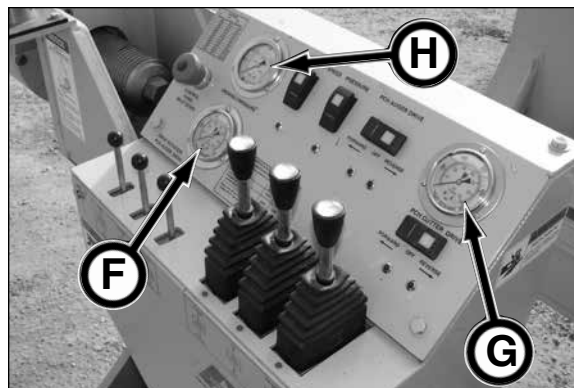

- 38. Advance PCH as far forward as possible. Turn off all power.
- 39. Disconnect jumper hoses and jetting hose.

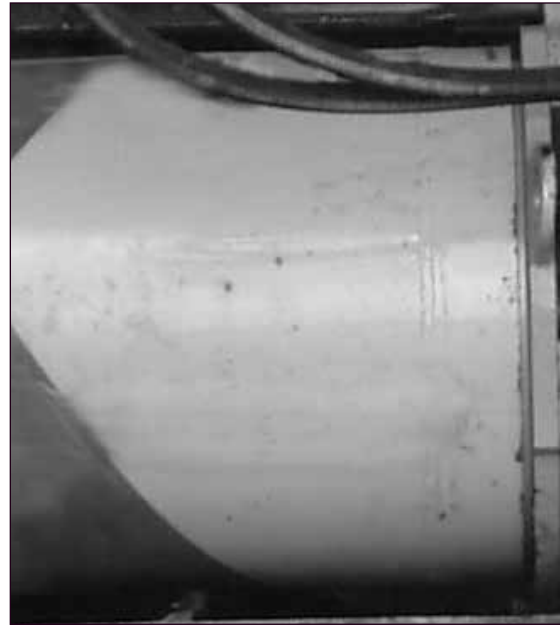

- 40. Adjust the bottom roller bracket (A) to support the PCH before retracting push plate.
- 41. Proceed to Installing Powered Cutter Head - 20, 22.5 & 28.5 - Rear Section in this section.



INSTALLING POWERED CUTTER HEAD 20, 22.5 & 28.5 - REAR SECTION

1. Once front section of the powered cutter head (PCH) is launched, disconnect the hydraulic jumper hoses between the PCH and the quick disconnects, and the jetting hose from supply source. Set these items aside for next job site usage.



2. Remove drive extension (A) from front section auger shaft (B).

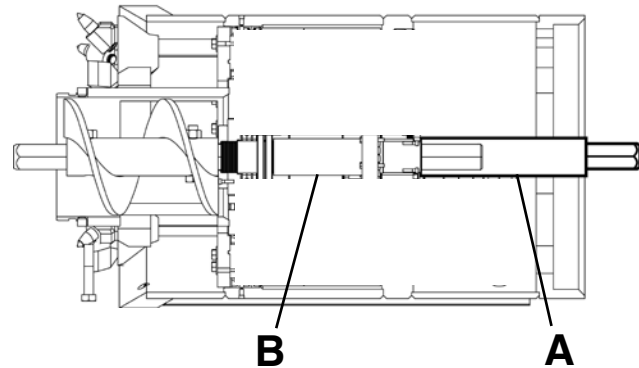

3. Apply thread lubricant to alignment pins (C) and install into front section.



4. Connect auger drive coupler (D) onto auger shaft (E) of front section. Apply grease or thread lubricant for ease of assembly.

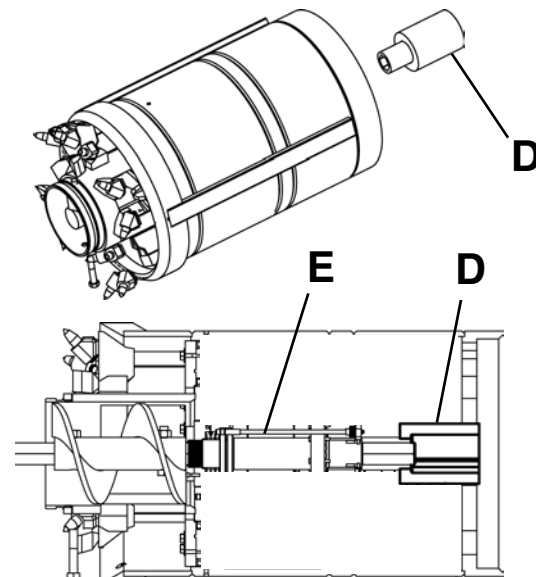

(continued on next page)

5. Remove auger drive adapter from GBM thrust plate hub.

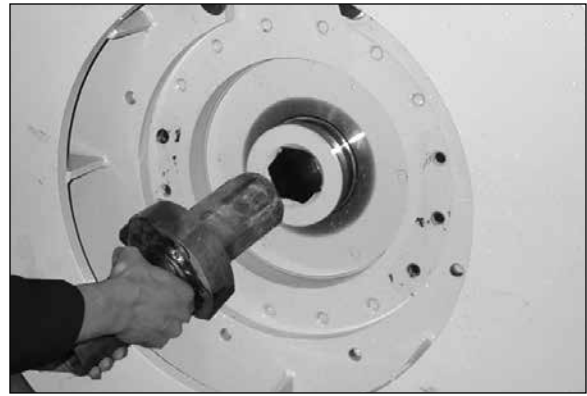

- 6a. (Earlier Models) Install lifting eyes (A) in rear section of PCH by removing o-ring plugs (B) and threading the lifting eyes completely into PCH body.

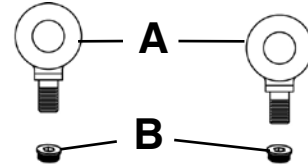

- 6b. (Later Models) Later models are not equipped with lifting lugs and lifting eyes. Use a properly rated lifting strap for the weight of the PCH. Refer to section 12, Specifications for the weight of the PCH rear section.

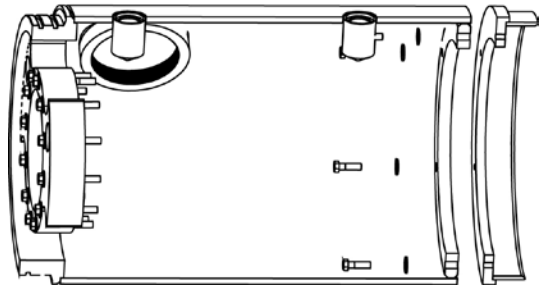

WARNING Suspended loads may fall and cause severe personal injury or death.

If a hydraulic hose breaks from the boom of a crane/excavator, or the lifting support fails, the boom and/or load can fall instantly.

Do not stand or walk under a suspended load.

NOTICE If an increaser kit was added on your PCH, use the original base machine size thrust plate extension for jacking the front section. When jacking the PCH rear section, the original size thrust plate must be replaced with the increaser kit sized thrust plate.

WARNING DO NOT tip PCH while lowering into launch shaft to prevent PCH from slipping out of lifting straps (if used). Otherwise, severe injury or death may result from falling PCH.

7. Lower rear section, in a level position, on GBM frame.

8. Lubricate sealing rings on front end of rear section.

(continued on next page)



9. Connect 3/4 quick disconnects between front and rear sections.
10. Feed jetting line through rear section and connect to water filter inside rear section.



11. Advance the GBM thrust plate so the bell end of the PCH rear section is aligned and flush with thrust plate.

NOTICE

Carefully route hoses through the opening in the thrust plate so hoses are not pinched.

12. Connect two 3/4" hydraulic hoses with 1" quick disconnects to multi-port quick disconnect from back of rear section. Connect two 3/4" hydraulic hoses with 3/4" quick disconnects to quick disconnects on GBM frame.

The 3/4" disconnects are the hoses for the powered cutter head drive. The 1" disconnects are the hoses for the powered cutter head auger drive.



13. Check auger drive for proper speed. The auger should rotate at approximately 40 - 45 rpm. When using the P275T Power Pack with the PCH 20, PCH 22.5, or the PCH 28.5, the engine speed must be reduced to 1500 rpm to prevent over speeding of the PCH motors. The P275T pump flow will exceed the input flow requirements when operating the engine above 1500 rpm. Running engine faster than 1500 rpm may result in premature wear to cutter bits and hydraulic components.



(continued on next page)

- 14. Remove port covers.
- 15. Connect jetting hose to water filter.



- 16. Place male quick-disconnect into position on female quick-disconnect block, and then when the reception shaft personnel communicate that it is clear to proceed with the auger drive hookup, rotate handle DOWN (A) until release button (B) pops out. The multi-port quick disconnect is now locked into place.

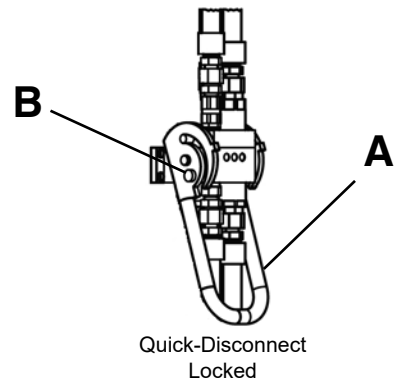

- 17. Rotate auger drive to align key (C) shaft (D) with auger drive coupler (E).

NOTICE Key must be installed properly in slot of the auger drive coupler, otherwise auger will not turn. Position key in slot on coupler at 12 o'clock position for ease of installation.

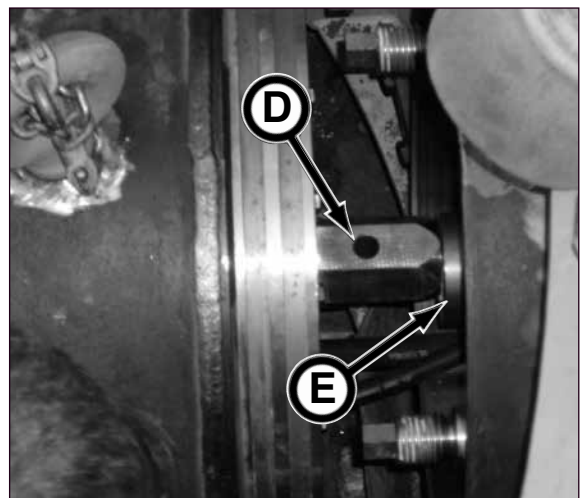
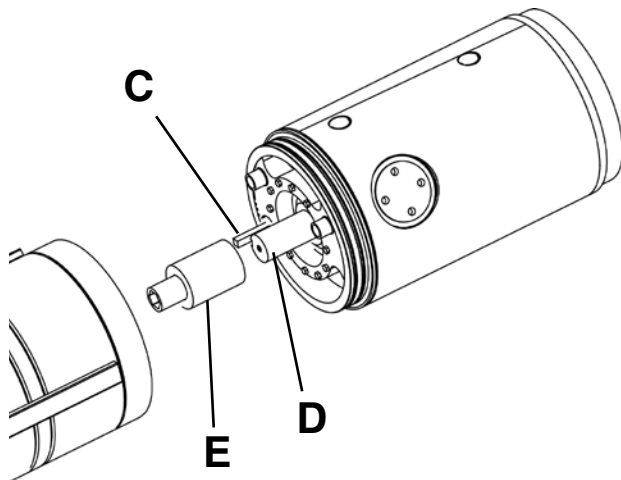

(continued on next page)

18. Once key is aligned, advance rear section to front section. Alignment pins should be installed and tightened through openings (A) in rear section port covers.

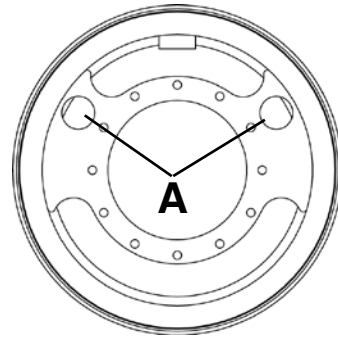

19. When the reception shaft personnel communicate that it is clear to rotate auger, test auger drive to be sure key shaft is properly installed by operating auger drive switch (B) on control panel. Augers must rotate so spoils are removed from the reception shaft.

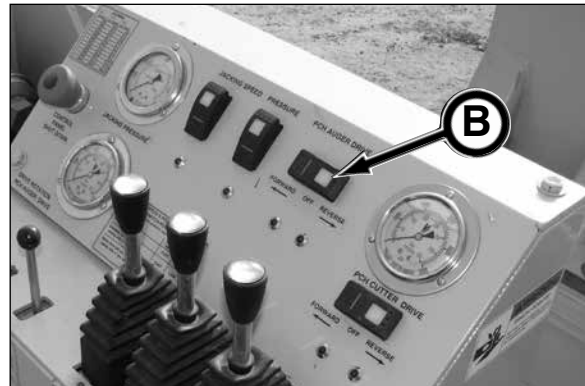

20. Install flat washers and retaining nuts to alignment pins. Tighten securely.

(continued on next page)



21. Reinstall port covers.
22. Disconnect lifting straps and remove from launch shaft. Remove lifting eyes and reinstall o-ring plugs.
23. Connect jetting hose to supply source. Turn jetting source ON before advancing PCH.



24. Advance PCH by rotating cutter head, PCH auger (CCW) drive and extending thrust cylinders.



NOTICE

After PCH front section is launched, move the PCH auger drive pressure switch to HIGH position.



25. While jacking the PCH, monitor the auger drive rotation pressure with gauge (A) and the cutter head operating pressure with gauge (B) to determine advance rate.

Normal operating pressure:

- auger - 2,000 - 4,000 psi (13.790 MPa - 27.579 MPa)
- cutter head - 2,000 - 4,000 psi (13.790 MPa - 27.579 MPa)

NOTICE

The maximum system operating pressure is 5,000 psi (34.474 MPa). Your operation will stall when rotational pressure is at 5,000 psi (34.474 MPa).

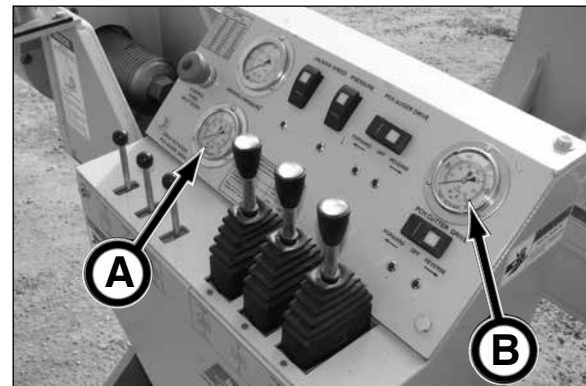

(continued on next page)

26. Advance PCH as far forward as possible so the PCH is supported by the bottom roller bracket.

⚠ WARNING When installing next pipe or when removing casing and auger in reception shaft, release multi-port quick disconnect to disable the auger drive functions. Failure to do so could result in serious injury from contact with rotating auger. Lock or reconnect multi-port quick disconnect **ONLY** after it has been communicated from the reception shaft personnel that advancement can proceed.



27. With the addition of the PCH rear section in the pipe line, a section of casing/auger must be removed in the reception shaft.

28. Using a hoist to keep the casing/auger in line with the pipeline, remove keepers from the casings.

NOTICE Remove bottom keepers first, otherwise the weight of the casing and auger will make it difficult to remove the bottom keepers once the top keepers are removed.



29. Slide the casing out to gain access to the auger joint.

NOTICE Casing must be supported underneath to maintain alignment. Failure to do so will deteriorate the bottom of the bore hole resulting in poor grade alignment.



30. Disconnect the augers by removing the auger bolt and nut that was installed in the launch shaft (back bolt as shown).



(continued on next page)

⚠ WARNING Auger may fall out of casing and cause severe injury or death if casing tips or hits an obstruction. Properly install safety chain assembly or auger pin to augers and casings before lowering into or lifting out of shaft. Do not stand or walk under a load.

31. Slide the auger into the casing. Secure auger to casing with safety chain assembly or auger pin.
32. Remove auger casing from reception shaft.
33. Continue removing auger casings as needed until the powered cutter head reaches the reception shaft.



34. Retract GBM thrust block and disconnect the four 3/4" hydraulic hoses and jetting hose.



35. Install pipe lube 5/8" hose to rear section.
36. Connect four 3/4" 100' hydraulic hoses to rear section.



(continued on next page)

NOTICE

To protect your product pipe, you must be sure the product pipe rating can withstand the thrust pressure of the GBM. The factory setting is 6,000 psi (41.4 MPa). If your pipe is rated lower than 200 ton, the GBM thrust pressure in the P275T or P150Q Power Pack **MUST** be readjusted. Failure to do so will break the pipe. Refer to Operation section, subsection Power Pack Operation, Adjusting Thrust Pressure.

- 37. Route the hoses through several pipe (5-8 depending on room) back to quick disconnects.

NOTICE

Be sure to position hoses through pipe so spigot end of pipe goes into the pipeline first.

NOTICE

Production is optimized by having the casing in the reception shaft staged to be removed during installation of the next product pipe. To achieve this production, you may have to install a 1' or 2' length pipe behind the cutter head to expose one casing in the reception shaft for removal. Then proceed with normal pipe length.



⚠ WARNING

Suspended loads may fall and cause severe personal injury or death.

If a hydraulic hose breaks from the boom of a crane/excavator, or the lifting support fails, the boom and/or load can fall instantly.

Do not stand or walk under a suspended load.



- 38. Lower pipe into shaft. Pull hoses through pipe as pipe is being positioned on jacking frame.



NOTICE

Be sure fiber ring is in thrust ring of rear section for cushioning or pipe.

- 39. Route lube and jetting hoses through pipe.



(continued on next page)

40. Position spigot end of pipe to the PCH rear section.
41. Route hoses through thrust plate. Be sure hoses will not be pinched.
42. Advance thrust plate to bell end of pipe. Be sure fiber ring is in pipe prior to jacking. Be sure hydraulic hoses will not be pinched while advancing pipe.
43. Reconnect jetting hose. The lube hose does not need to be connected until the third or fourth pipe.
44. Push product pipe into pipeline by rotating PCH cutter head, PCH auger (Forward) drive and extending the thrust cylinders.

NOTICE Be sure to properly support the product pipe with roller bracket.

WARNING When installing next pipe or when removing casing and auger in reception shaft, release multi-port quick disconnect to disable the auger functions. Failure to do so could result in serious injury from contact with rotating auger. Lock or reconnect multi-port quick disconnect **ONLY** after it has been communicated from the reception shaft personnel that advancement can proceed.

45. Continue adding pipe and hoses as needed until the powered cutter head reaches the reception shaft. Be sure to connect the lube hose starting with pipe number three or four.

NOTICE Monitor jacking pressure to not exceed product pipe rated jacking tonnage. Doing so will result in pipe damage.

46. With the addition of each section of product pipe, a section of casing/auger must be removed from the reception shaft.
47. Once the powered cutter head is removed from the reception shaft (refer to Removing Powered Cutter Head From Reception Shaft, in this section), add product pipe as needed until the product pipe reaches the reception shaft per job requirement.
48. Proceed to Removing Powered Cutter Head From Reception Shaft in this section.



INSTALLING POWERED CUTTER HEAD 36 & 44 - FRONT SECTION

NOTICE

When using the Powered Cutter Head (PCH), the contractor MUST plan for jetting and lubrication, whether or not it is needed for the project. If a "change of conditions" occurs, and the PCH is not plumbed for jetting/lubrication or is not being used, in many instances, the PCH will become plugged. The use of jetting and lubrication helps reduce jacking pressures. For more information, refer to Using Powered Cutter Head Jetting & Lubrication in this section. Akkerman highly recommends to always use jetting and lubrication on a PCH drive. It is recommended to start with jetting at 1,000 psi and lower pressure/water volume if required.

1. Once the reaming head assembly can be removed from the reception shaft, remove the keepers from the reaming head assembly and lead casing.

NOTICE

As the reaming head and casings are advanced into the reception shaft, the reaming head assembly and casings must be supported to maintain alignment. Failure to do so will deteriorate the bottom of the bore hole resulting in poor grade alignment.



NOTICE

To reduce rotational pressures during launch of PCH, rotate augers to remove spoils contained in augers and casings to launch or reception shaft.

NOTICE

Using a hoist to keep the reaming head in line with the pipe line, remove bottom keepers first, otherwise the weight of the casing and auger will make it difficult to remove the bottom keepers once the top keepers are removed.



2. Remove reaming head assembly casing by sliding the casing forward.



(continued on next page)

3. Remove casing thrust adapter (A) from the GBM frame.

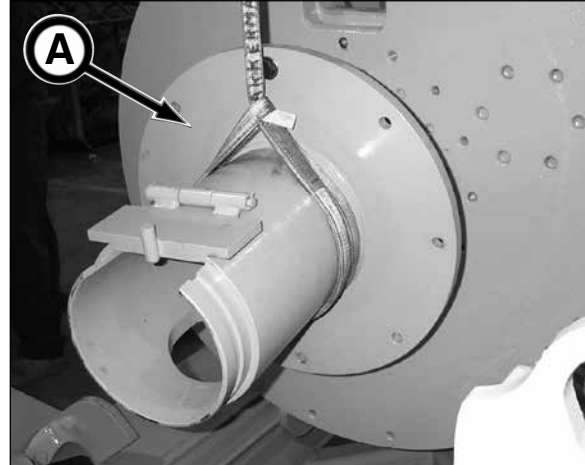

4. Install torque plate (B) to thrust plate with sixteen 3/4-10 x 3 in. bolts and flat washers.

NOTICE The notches for the PCH torque pins must be located above the center line to align with PCH.

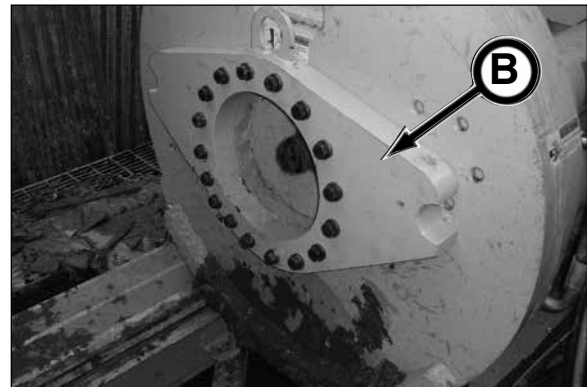

5. Install torque pins (2 places) (C) into rear of front section.



(continued on next page)

⚠ WARNING Suspended loads may fall and cause severe personal injury or death.

If a hydraulic hose breaks from the boom of a crane/excavator, or the lifting support fails, the boom and/or load can fall instantly.

Do not stand or walk under a suspended load.



⚠ WARNING DO NOT tip PCH while lowering into launch shaft to prevent PCH from slipping out of lifting straps (if used). Otherwise, severe injury or death may result from falling PCH.

- Using a properly rated lifting strap for the weight of the PCH (refer to section 12, Specifications of the weight of the PCH), lower powered cutter head (PCH) front section, in a level position, onto GBM frame.



NOTICE When installing PCH, be sure it is positioned so the two alignment pin holes (A) are above center line indicating this is the top position. Positioning PCH in upside down position will result in a gear case oil leak in the rear section of the PCH.

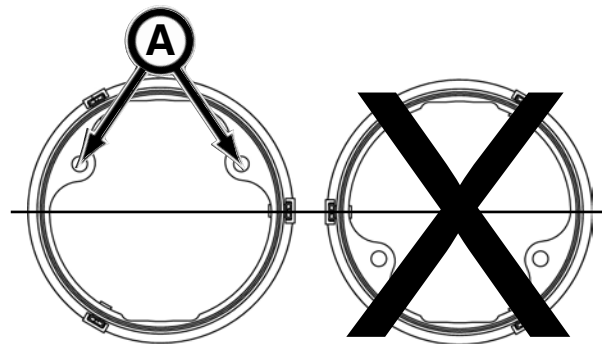

Correct PCH Position

Incorrect PCH Position

- If not already installed, connect jetting hose to PCH.

- Install jetting hose to jetting inlet hose (B).
- When launching front section, install hose to jetting supply source. Test jetting at this time to be sure all four nozzles are discharging water properly with no leaks.

NOTICE Once front section is launched, disconnect jetting hose from jetting supply and route jetting hose through rear section, to water filter and then connect to supply source. Add additional hoses as needed.

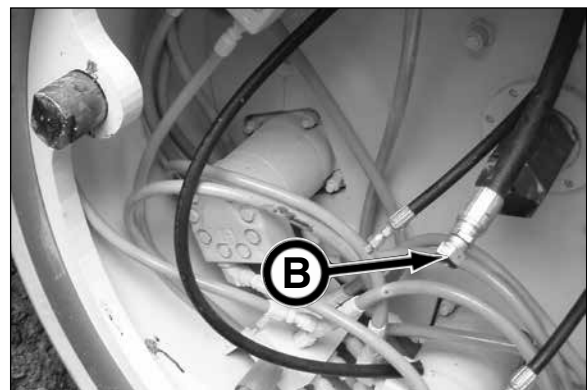

(continued on next page)

- Advance thrust plate so the spigot end of the PCH is aligned and flush with thrust plate on GBM frame.

NOTICE Carefully align torque pins on PCH in torque plate as the thrust plate is advanced.



WARNING Safety glasses must be worn while using power equipment (air tools). Failure to do so could cause severe injury from flying debris.

- With the auger flighting (A) lined up, attach the auger ends with one 3/4 x 6 in. bolt and nylock lock nut. Tighten the nut so the end of the nut is flush with the end of the bolt. Do not overtighten.

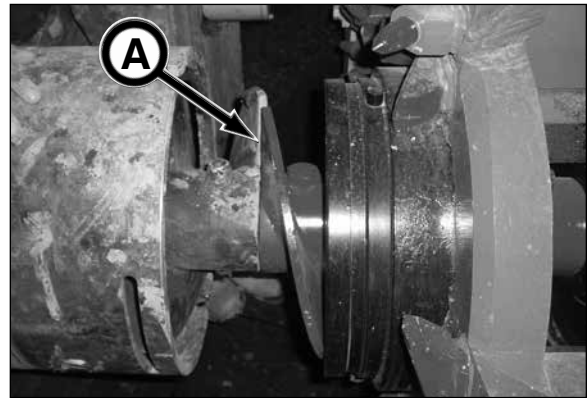

- Advance PCH auger casing to last casing by aligning notches on last casing with top and bottom alignment guides (B) on PCH auger casing.

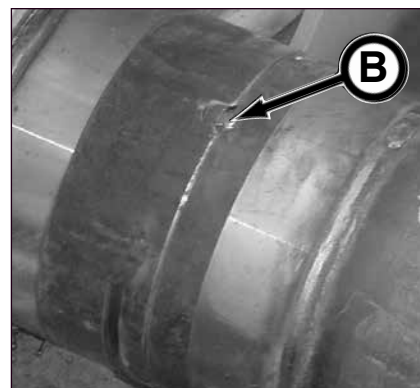

(continued on next page)

11. Install four casing joint keepers at the 2 o'clock, 4 o'clock, 8 o'clock, and 10 o'clock positions to lock the casings together.



12. With crane (or other lifting device) supporting the PCH, retract the GBM thrust plate and install the drive extension (A) into the PCH and connect into thrust plate hub / shaft on GBM thrust plate.

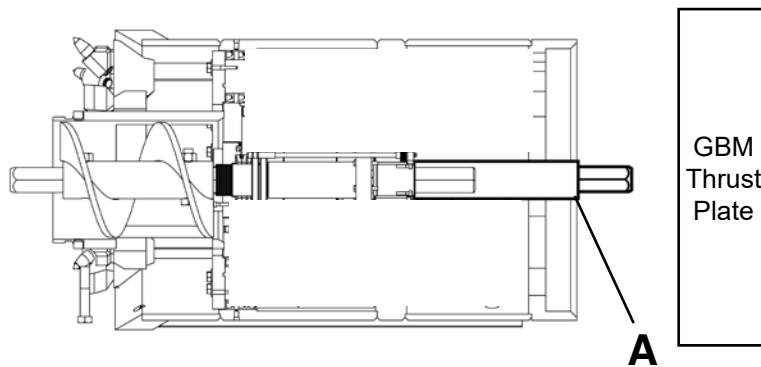
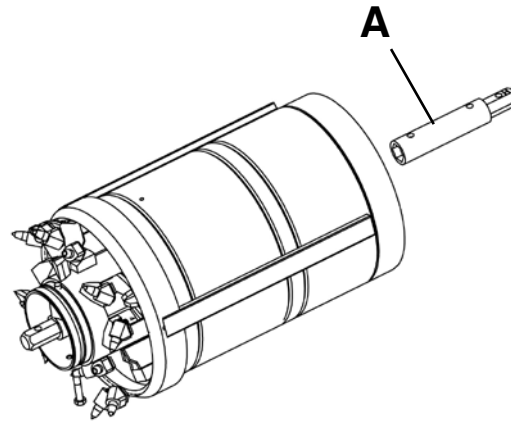

(continued on next page)

13. Advance thrust plate with thrust cylinder control so the bell end of the PCH is aligned and flush with PCH thrust plate on GBM frame by aligning torque pins with notches on torque plate.



NOTICE Be sure auger drive shaft is aligned with thrust plate by aligning flats on outside of auger shaft adapter and flats on auger drive shaft. Failure to do so will cause premature wear to auger components.

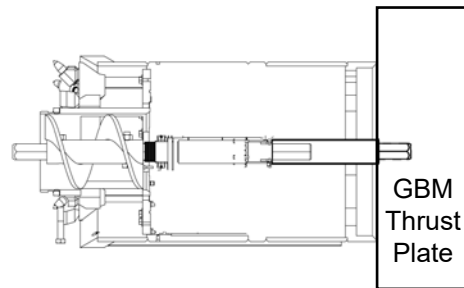

14. Disconnect lifting straps from PCH and remove from launch shaft.

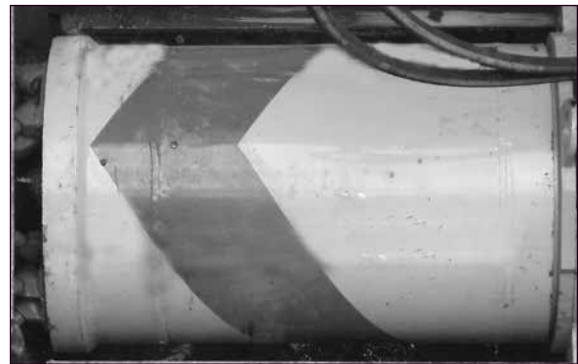

15. Connect two jumper hoses (not shown) to the two 1" hose quick disconnects (A) from PCH to the quick-disconnects on GBM. These are the pressure and return hoses for the cutter head drive.

NOTICE The jumper hoses are used only while launching the front and rear PCH sections.

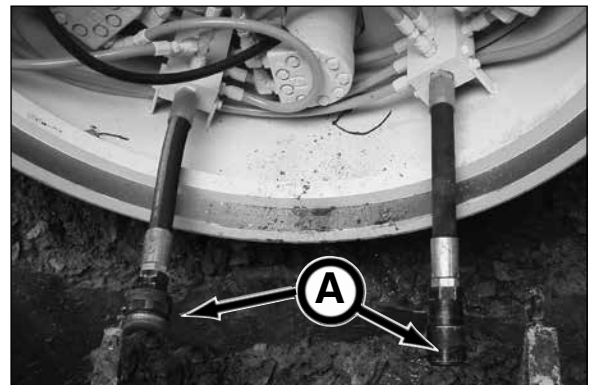

(continued on next page)

16. In the reception shaft, remove the reaming head auger by removing the auger bolt and nut that was installed in the launch shaft (back bolt as shown). Replace auger into the reaming head assembly casing.



⚠ WARNING Auger may fall out of casing and cause severe injury or death if reaming head assembly tips or hits an obstruction.

Properly install safety chain assembly or auger pin to augers and reaming head/casing BEFORE lowering into or lifting out of shaft.

Do not stand or walk under a load.

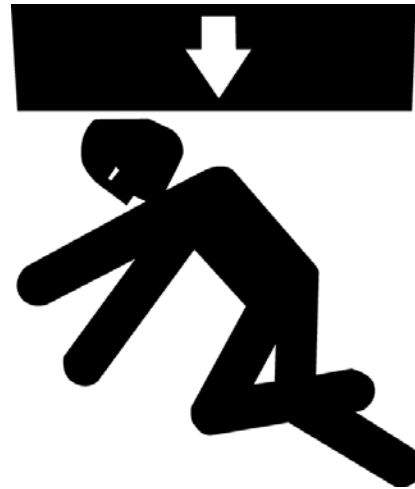

17. Install safety chain assembly or auger pin to auger to secure auger into reaming head assembly. For proper installation of safety chain, refer to Installing Safety Chain Assembly/Casing Auger Pin To Auger & Casing in this section.
18. Remove the reaming head assembly from reception shaft.

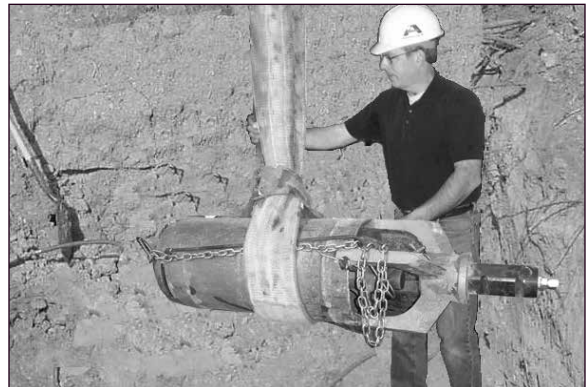

(continued on next page)

⚠ WARNING Contact with rotating auger or cutter head can result in serious injury. Before operating the cutter head and auger, be sure the personnel in the launch and reception shafts are clear of any moving parts.

19. Flip the PCH cutter head switch (A) to Forward and check for proper rotation and operation, and be sure there are no leaks. Then flip switch to Reverse and check for proper rotation and operation.

NOTICE The Control Panel Shutdown control (B) must be pulled out for the PCH cutter head control to function. Be sure power supply cord from pendant is connected to Control Panel Power Supply 12VDC connection on side of control panel.

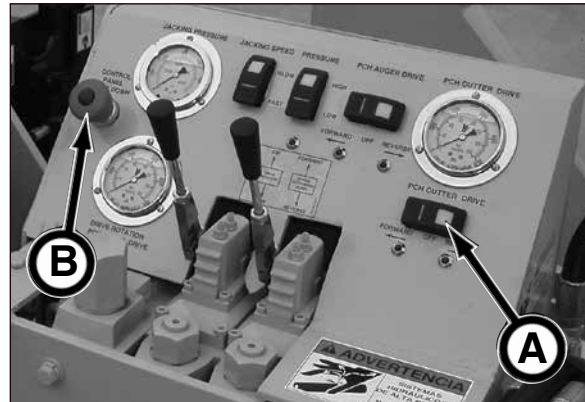

SN 1-3



SN 4 & After

20. Check cutter bit speed rotation. The P275T Power Pack engine speed must be at full rpm.

(continued on next page)

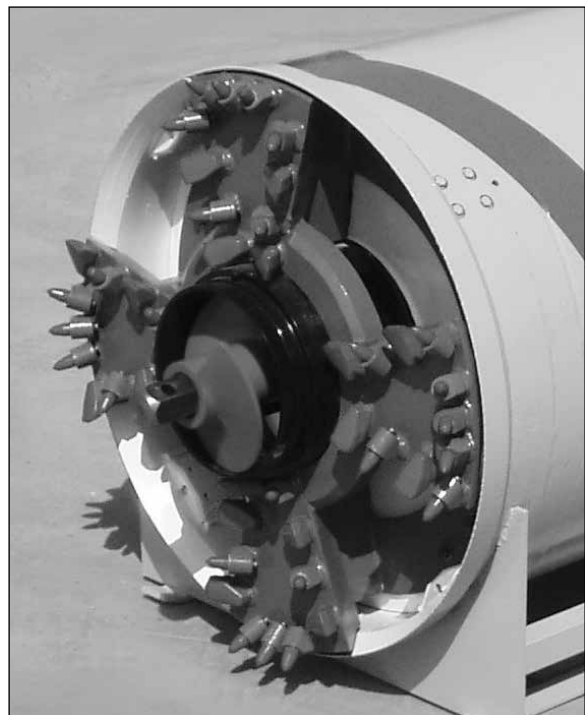

21. Rotate the cutter head with PCH cutter head switch (A) in forward position, turn on jetting at supply source, and rotate the auger counterclockwise (CCW) with the drive rotation control (B) so the spoils are removed to reception shaft.

Using a communication device between the launch and reception shafts, contact the personnel in reception shaft to confirm that the auger is rotating in the counterclockwise direction and that the spoils are going into the reception shaft.

22. Set the rotation pressure switch (C) to High and the jacking speed switch (D) to Slow.
23. Start jacking (advancing) the PCH by extending the GBM thrust cylinders using the thrust cylinder control (E) while rotating the PCH cutter head with switch (A) in forward position and drive rotation control (B) in counterclockwise (CCW) position.

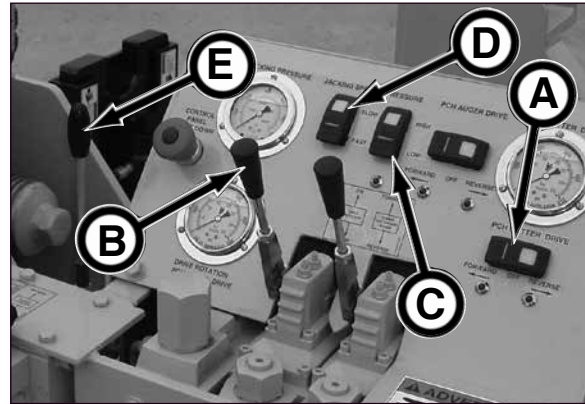

SN 1-3

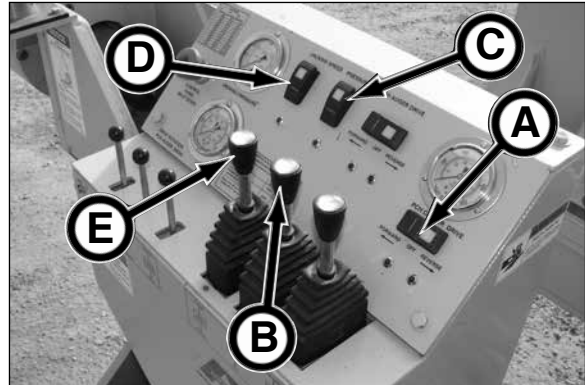

SN 4 & After



24. While jacking the PCH, monitor the auger drive rotation pressure with gauge (F), the cutter head operating pressure with gauge (G), and the jacking pressure with gauge (H) to determine advance rate.

NOTICE

On 3" hex augers, the maximum operating pressure is 5,000 psi (High pressure).

Normal operating pressure:

Auger - 2,000 - 4,000 psi
(13.790 MPa - 27.579 MPa)

Cutter head - 2,000 - 4,000 psi
(13.790 MPa - 27.579 MPa)

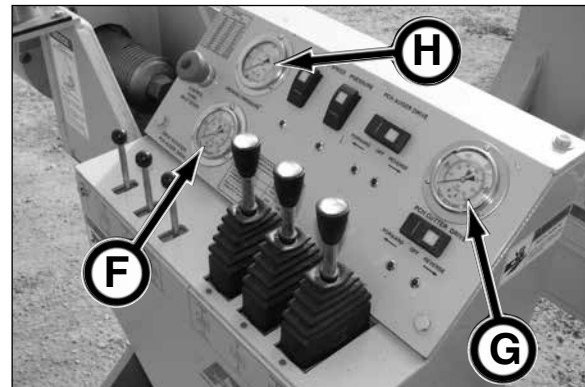

(continued on next page)

25. Advance PCH as far forward as possible. Turn off all power including power pack.

26. Disconnect jumper hoses.

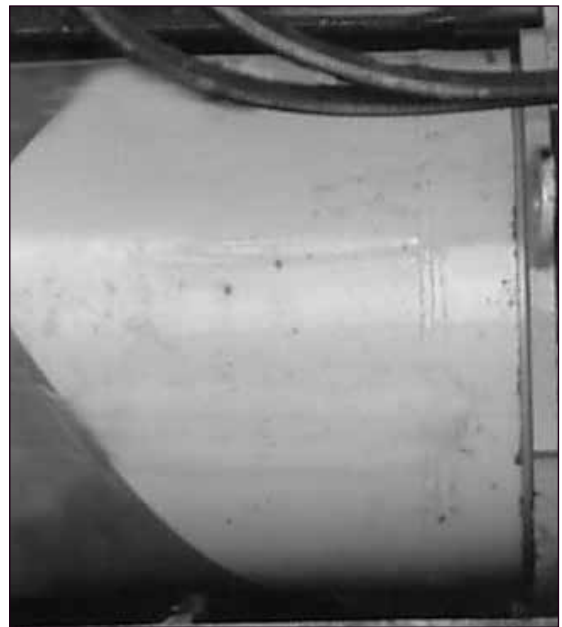

27. Adjust the bottom roller bracket (A) to support the PCH.

28. Proceed to Installing Powered Cutter Head 36 & 44 - Rear Section in this section.



INSTALLING POWERED CUTTER HEAD 36 & 44 - REAR SECTION

1. Once front section of the powered cutter head (PCH) is launched, disconnect the hydraulic hoses between the PCH and the quick disconnects, and the jetting hose.



2. Remove torque pins (A) from front section.

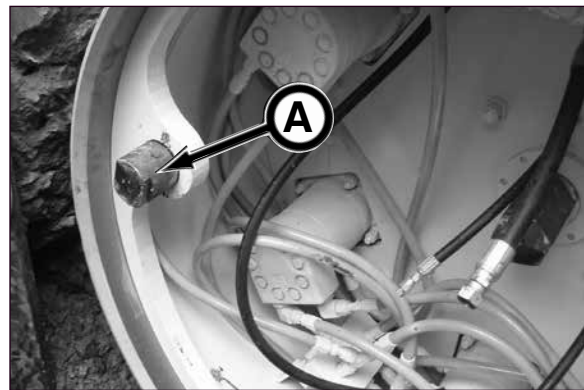

3. (PCH 44 SN 1 & 2 only) Remove drive extension (B) from front section auger shaft (C).

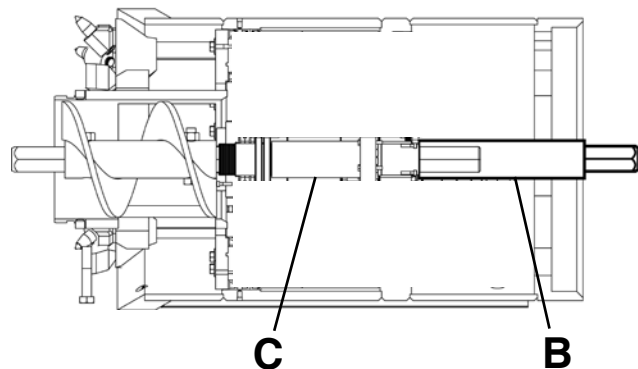

(continued on next page)

4. Install alignment pins (A) into front section.

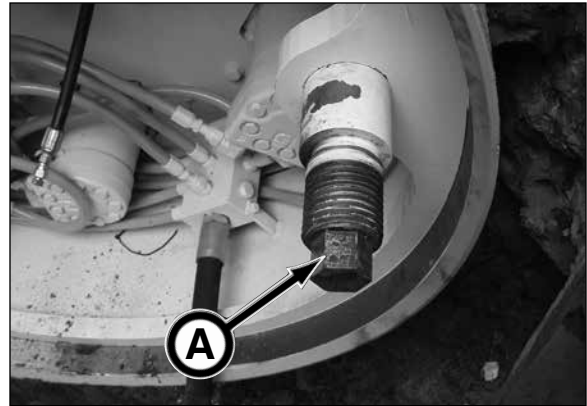

5. Connect auger drive coupler (B) or drive extension (C) (if not already installed) onto auger shaft (D) of front section.

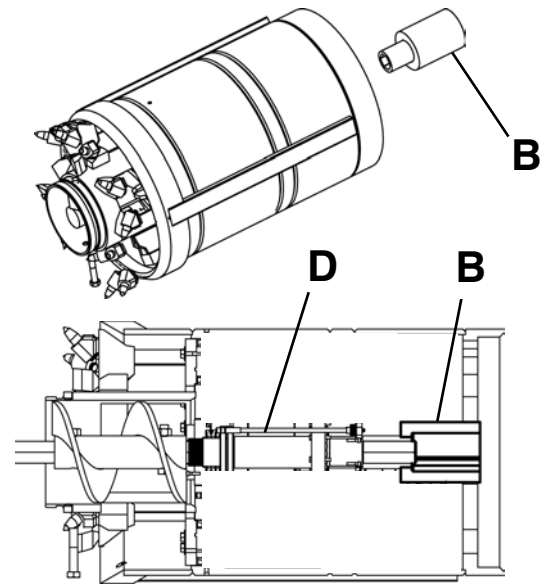

PCH 44 SN 1 - 2

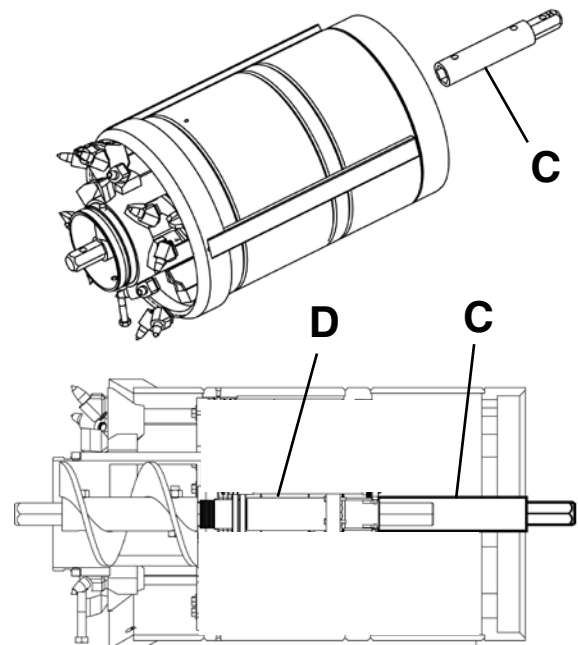

PCH 36 & PCH 44 SN 3 & After

(continued on next page)

- 6a. (Earlier Models) Install lifting eyes (A) by removing o-ring plugs (B) and threading the lifting eyes completely into PCH body.
- 6b. (Later Models) Later models are not equipped with lifting lugs and lifting eyes. Use a properly rated lifting strap from the weight of the PCH. Refer to section 12, Specifications for the weight of the PCH rear section.

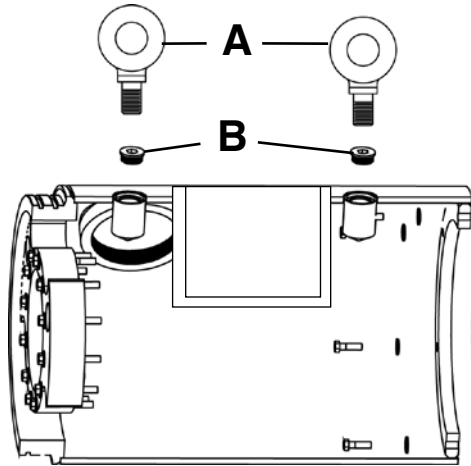

⚠ WARNING Suspended loads may fall and cause severe personal injury or death.

If a hydraulic hose breaks from the boom of a crane/excavator, or the lifting support fails, the boom and/or load can fall instantly.

Do not stand or walk under a suspended load.



⚠ WARNING DO NOT tip PCH while lowering into launch shaft to prevent PCH from slipping out of lifting straps (if used). Otherwise, severe injury or death may result from falling PCH.

7. Lower rear section, in a level position, on GBM frame.
8. Lubricate sealing rings on front end of rear section.



9. Connect 1" cutterhead quick disconnects between front and rear sections.
10. Feed jetting line through rear section and connect to water filter.



(continued on next page)

11. Install torque pins (A) into rear section.

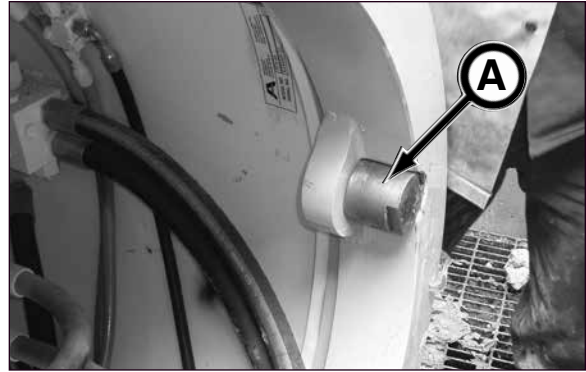

12. Advance the GBM thrust plate with the thrust cylinder control so the bell end of the PCH rear section is aligned and flush with PCH thrust plate on GBM frame by aligning torque pins with notches (B) on torque plate.

NOTICE

Carefully route hoses through opening in the thrust plate so hoses are not pinched.

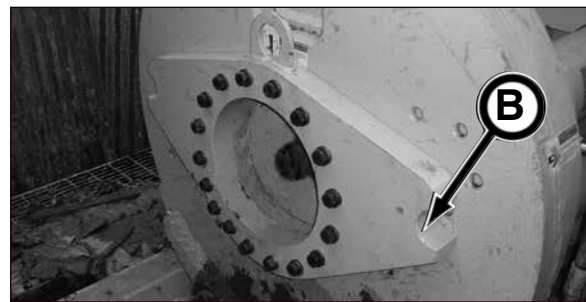

13. Connect two 1" hydraulic hoses for PCH auger to multi-port quick disconnect (C) from back of rear section. Connect two 1" hydraulic hoses for PCH cutter head to quick disconnects (D) on GBM frame.

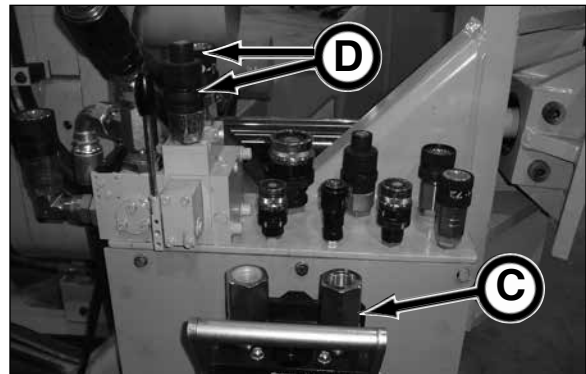

4812A SN 1-3

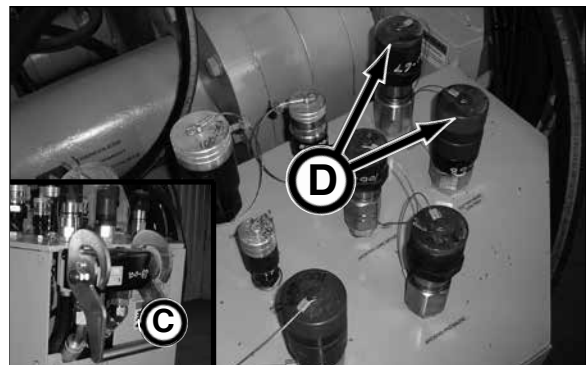

4812A SN 4 & After

(continued on next page)

14. Check auger drive for rotation. The P275T Power Pack engine speed must be at full rpm for proper rotation speed.



15. Remove port covers.
16. Connect jetting hose to supply source.



17. Place male quick-disconnect into position on female quick-disconnect block, and then when the reception shaft personnel communicate that it is clear to proceed with the auger drive hookup, rotate handle DOWN (A) until release button (B) pops out. The multi-port quick disconnect is now locked into place.

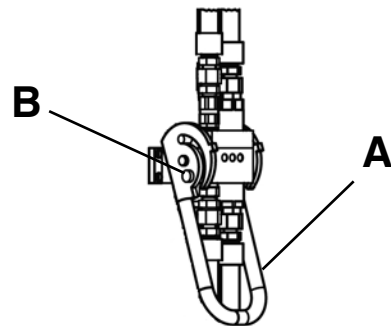

*Quick-Disconnect
Locked*

(continued on next page)

NOTICE

Keys must be installed properly in slots of the auger drive coupler, otherwise auger will not turn.

- 18a. (PCH 44 SN 1 & 2 Only) Rotate auger drive to align both keys (A) and shaft (B) with auger drive adapter (C).

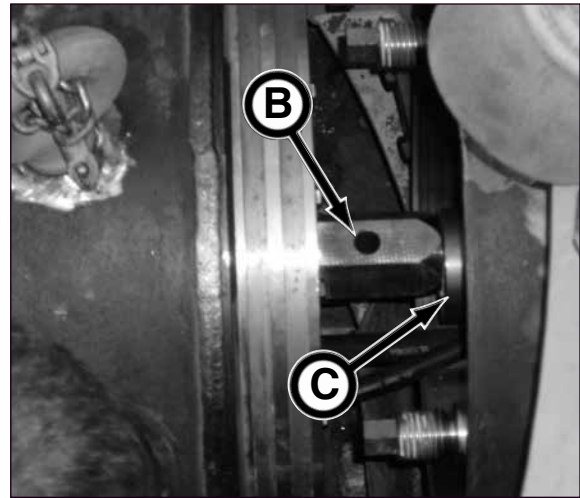
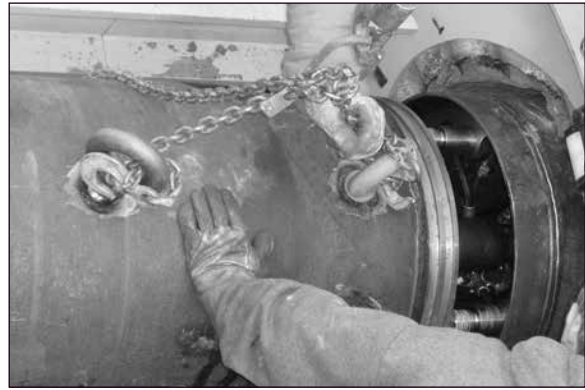
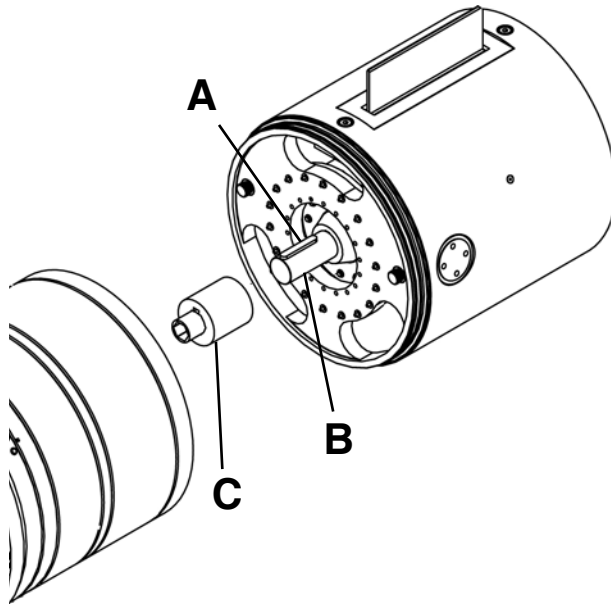

- 18b. (PCH 36 & PCH 44 SN 3 & After) Rotate auger drive to align drive extension (D) with rear section auger drive hub (E).

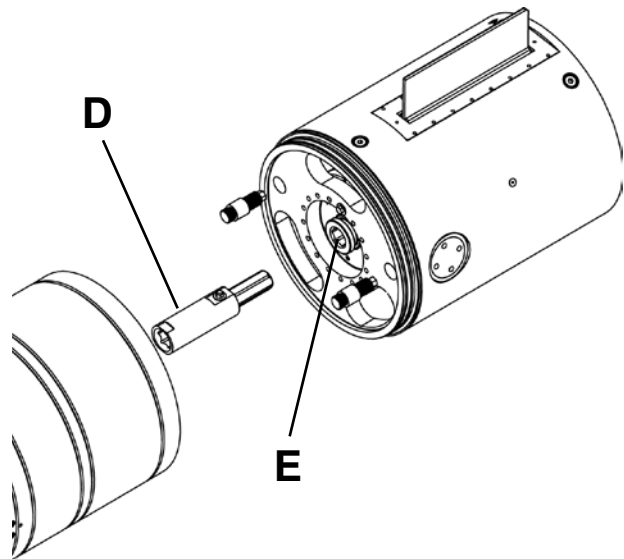

(continued on next page)

19. Once keys/shaft (PCH 44 SN 1 & 2) or extension/hub (PCH 36 & PCH 44 3 & After) are aligned, advance rear section to front section. Alignment pins should go through openings (A) in rear section.

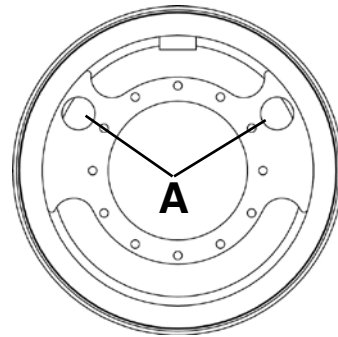
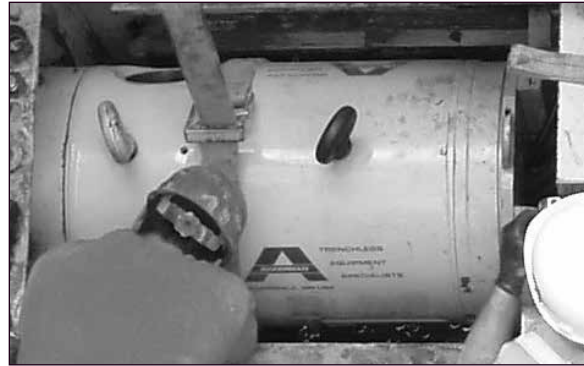

20. Test auger drive to be sure keyed shaft is properly installed by operating auger drive switch (B) on control panel or by pushing PCH auger control lever (C) forward. Augers must rotate (CCW when looking toward reception shaft) so spoils are removed from the reception shaft.

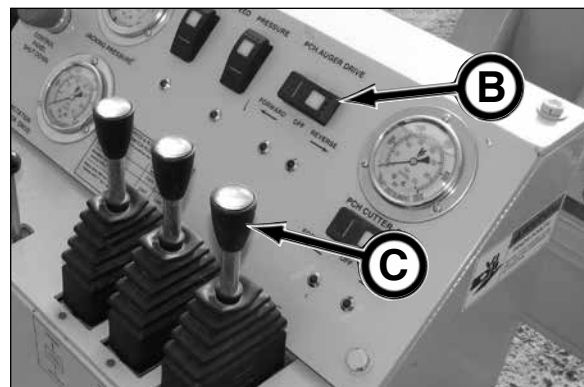

21. Install flat washers and retaining nuts to alignment pins. Tighten securely.



22. Reinstall port covers.
23. Disconnect lifting straps and remove from launch shaft. Remove lifting eyes and reinstall o-ring plugs.



(continued on next page)

24. Advance PCH by rotating cutter head, PCH auger (CCW) drive and extending thrust cylinders.

NOTICE

Jetting must be ON before advancing PCH.



25. While jacking the PCH, monitor the auger drive rotation pressure with gauge (A) and the cutter head operating pressure with gauge (B) to determine advance rate.

Normal operating pressure:

- auger - 2,000 - 4,000 psi
(13.790 MPa - 27.579 MPa)
- cutter head - 2,000 - 4,000 psi
(13.790 MPa - 27.579 MPa)

NOTICE

The maximum system operating pressure is 5,000 psi (34.474 MPa). Your operation will stall when operating at 5,000 psi (34.474 MPa).

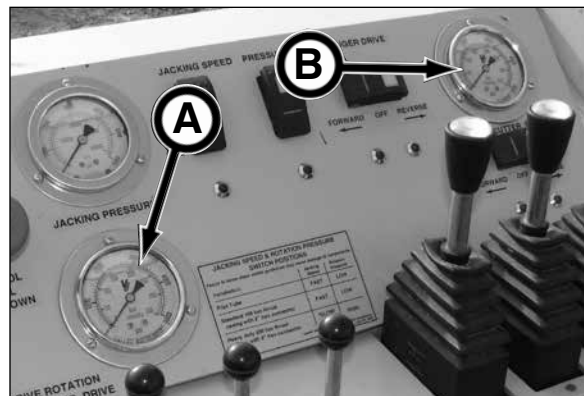

26. Advance PCH as far forward as possible so the PCH is still supported by the bottom roller bracket.

WARNING

When installing next pipe or when removing casing and auger in reception shaft, release multi-port quick disconnect to disable the auger drive functions. Failure to do so could result in serious injury from contact with rotating auger. Lock or reconnect multi-port quick disconnect ONLY after it has been communicated from the reception shaft personnel that advancement can proceed.



(continued on next page)

27. With the addition of the PCH rear section in the pipe line, a section of casing/auger must be removed in the reception shaft.

28. Using a hoist to keep the casing/auger in line with the pipeline, remove keepers from the casings.

NOTICE

Remove bottom keepers first, otherwise the weight of the casing and auger will make it difficult to remove the bottom keepers once the top keepers are removed.



29. Slide the casing out to gain access to the auger joint.

NOTICE

Casing must be supported to maintain alignment. Failure to do so will deteriorate the bottom of the bore hole resulting in poor grade alignment.



30. Disconnect the augers by removing the auger bolt and nut that was installed in the launch shaft (back bolt as shown).



⚠ WARNING

Auger may fall out of casing and cause severe injury or death if casing tips or hits an obstruction. Properly install safety chain assembly/casing auger pin to augers and casings before lowering into or lifting out of shaft. Do not stand or walk under a load.

31. Slide the auger into the casing. Secure auger to casing with safety chain assembly or auger pin.

32. Remove auger casing from reception shaft.

33. Continue removing auger casings as needed until the powered cutter head reaches the reception shaft.

(continued on next page)



34. Retract GBM thrust plate and disconnect the four 1" hydraulic hoses and jetting hose.



35. Remove torque plate from GBM thrust plate and remove torque pins from PCH rear section.
36. Install pipe support (A) to thrust plate with six 3/4-10 x 3 in. bolts and flat washers.



37. Extend dirt wing by using the reception shaft breakout tool power pack as follows:

Clean the area around all disconnects. Install dirt wing quick disconnects (B) to connections on breakout tool power pack.

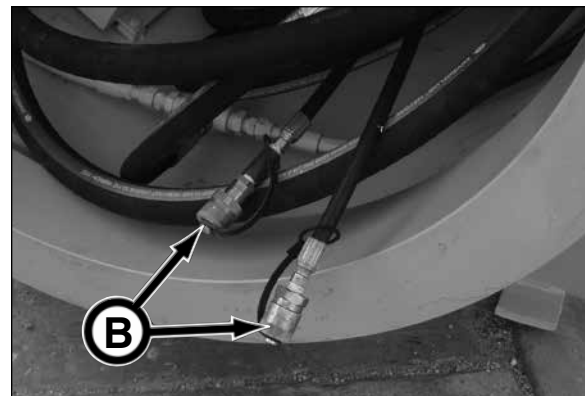

⚠ WARNING Electrical shock hazard could cause severe injury or death. Be sure the breakout tool power unit, plug and receptacle (must be three-pronged) are properly grounded and dry before plugging in and during operation.

Plug the breakout tool into 120 VAC outlet. If an extension cord is necessary, you must use a three-prong grounded extension cord.

Move the breakout tool control lever to port A. Depress switch on pump unit or remote controller to extend the dirt wing. Once dirt wing is fully extended, disconnect hoses and remove the breakout tool power pack from launch shaft.



(continued on next page)

38. Disconnect dirt wing disconnects and place near port covers for access in reception shaft.
39. Install pipe lube 5/8" hose to rear section.
40. Connect four 1" 80' hydraulic hoses to rabbit.



NOTICE

To protect your product pipe, you must be sure the product pipe rating can withstand the thrust pressure of the GBM. The factory setting is 6,000 psi (41.4 MPa). If your pipe is rated lower than 200 ton, the GBM thrust pressure in the P275T or P150Q Power Pack MUST be readjusted. Failure to do so will break the pipe. Refer to Operation section, subsection Power Pack Operation, Adjusting Thrust Pressure.

41. Route the hoses through several pipe (5-8 depending on room) back to quick disconnects on jacking frame.

NOTICE

Be sure to position hoses through pipe so bell end of pipe goes into the pipeline first.

NOTICE

Production is optimized by having the casing in the reception shaft staged to be removed during installation of the next product pipe. To achieve this production, you may have to install a 1' or 2' length pipe behind the cutter head to expose one casing in the reception shaft for removal. Then proceed with normal pipe length.



(continued on next page)

⚠ WARNING Suspended loads may fall and cause severe personal injury or death.

If a hydraulic hose breaks from the boom of a crane/excavator, or the lifting support fails, the boom and/or load can fall instantly.

Do not stand or walk under a suspended load.



42. Lower pipe into shaft. Pull hoses through pipe as pipe is being positioned on jacking frame.



NOTICE Be sure fiber ring is in bell end of pipe for cushioning of pipe.

43. Route lube and jetting hoses through pipe.

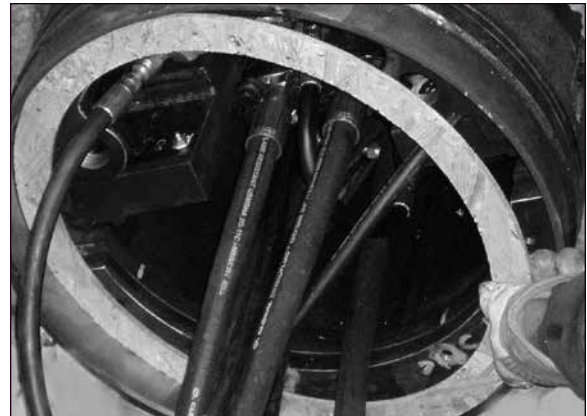

44. Position bell end of pipe to the PCH rear section.
45. Route hoses through thrust plate. Be sure hoses will not be pinched.
46. Advance thrust plate to spigot end of pipe. **Be sure fiber ring is in pipe prior to jacking** and be sure hydraulic hoses will not be pinched while advancing pipe.
47. Reconnect jetting hose and turn jetting ON. The lube does not need to be pumped until the third or fourth pipe.



(continued on next page)

NOTICE

For maximum diameter pipe, 48" OD, install the handled ring segment (A) in the opening of the thrust block to provide even thrust support on the pipe while advancing pipe.

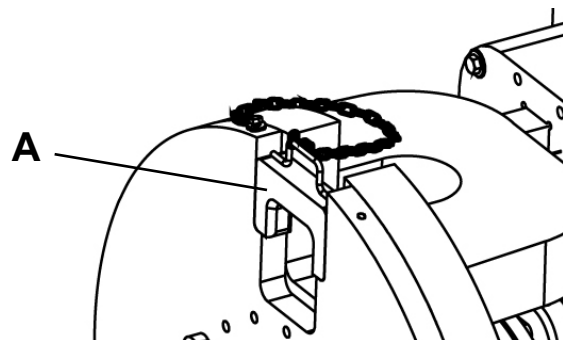

48. Push product pipe into pipeline by rotating PCH cutter head, PCH auger (Forward) drive and extending the thrust cylinders.

NOTICE

Be sure to properly support the product pipe with roller bracket.

WARNING

When installing next pipe or when removing casing and auger in reception shaft, release multi-port quick disconnect to disable the cutter head functions. Failure to do so could result in serious injury from contact with rotating auger. Lock or reconnect multi-port quick disconnect ONLY after it has been communicated from the reception shaft personnel that advancement can proceed.

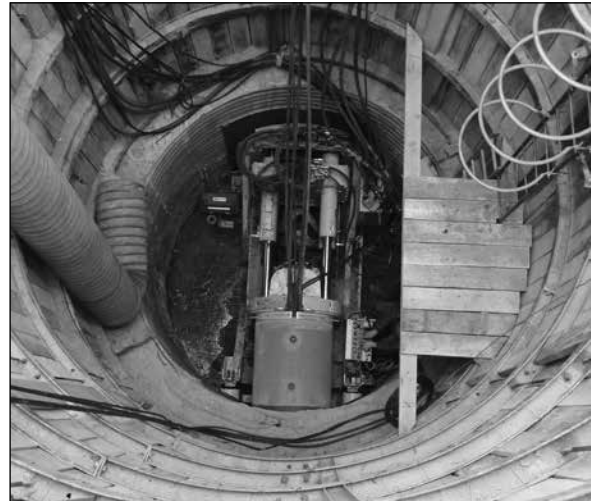

49. Continue adding pipe and hoses as needed until the powered cutter head reaches the reception shaft. Be sure to connect the lube hose starting with pipe number three or four.

NOTICE

Turn jetting and lube supply OFF during staging of next pipe.



50. With the addition of each section of product pipe, a section of casing/auger must be removed from the reception shaft.

51. Once the powered cutter head is removed from the reception shaft (refer to Removing Powered Cutter Head From Reception Shaft, in this section), add product pipe as needed until the product pipe reaches the reception shaft per job requirement.

52. Proceed to Removing Powered Cutter Head From Reception Shaft in this section.



REMOVING POWERED CUTTER HEAD FROM RECEPTION SHAFT

1. Disconnect winged casing (for PCH20, 22.5 and 28.5) or last casing (PCH36 - 44) from cutter head assembly and remove from reception shaft.

NOTICE

Do not remove PCH assembly with winged casing attached. Doing so will cause damage to the PCH auger casing.

2. (PCH36-44) Remove port cover to gain access to dirt wing hoses. Retract dirt wing with breakout tool power pack.



3. With the PCH supported, communicate with the launch shaft personnel to advance PCH until product pipe is exposed.

4. Disconnect the powered cutter head from the product pipe and disconnect and remove the hydraulic hoses, jetting hose, and pipe lube hose.



5. Remove PCH assembly from reception shaft.



6. Pull hoses back to launch shaft.

7. Proceed to Powered Cutter Head After Drive, section 9, Maintenance to perform required maintenance after the drive is complete.

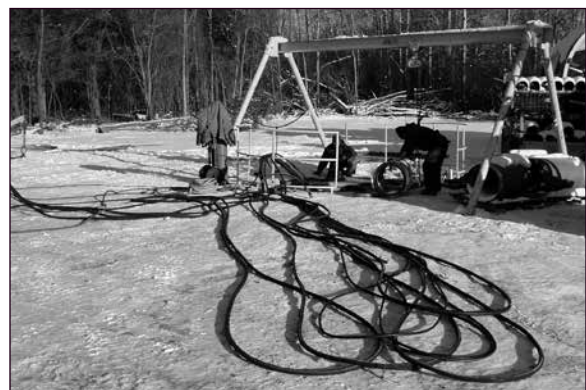

Operation

NOTES

Operation - Installing Product Pipe

THREE STEP METHOD: INSTALLING PRODUCT PIPE

NOTICE

If your product pipe is rated lower than 200 ton, you MUST readjust the thrust pressure per chart in the P275T Power Pack. Refer to Operation section, subsection Power Pack Operation, Adjusting Thrust Pressure.

1. With the reaming head or cutter head assembly removed from the reception shaft and the last section of casing/auger advanced as far forward as possible, remove auger drive adapter and the casing thrust adapter.



(continued on next page)

⚠ WARNING Suspended loads may fall and cause severe personal injury or death. Do not stand or walk under a load.

2. Install pipe thrust adapter (A) on thrust plate extension and secure with two 3/4 x 1-1/4 bolts and flat washers.

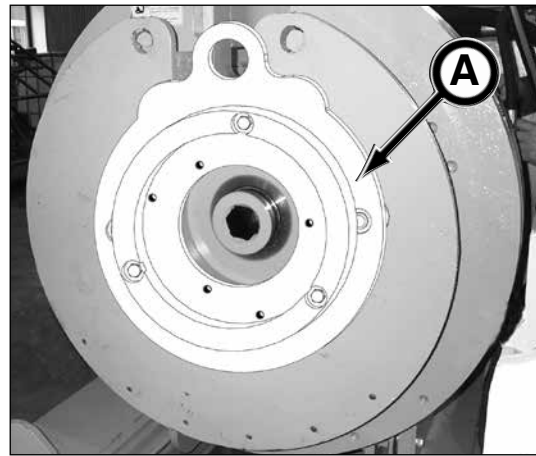

NOTICE The pipe thrust adapter assembly contains three separate pipe adapters for VCP; 8" ID (B), 10" ID (C), and 12" ID (D), mounted to the thrust plate (E) for shipping purposes only. Other pipe adapters are available upon request.

BEFORE using assembly for final pipe installation with the GBM, reassemble so only one pipe adapter is securely fastened to the thrust plate to prevent component damage.

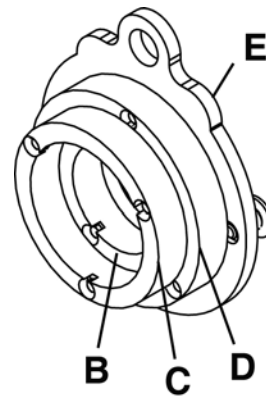

3. Install the casing to pipe adapter with wood ring to the end of the last casing by aligning the alignment guides.

NOTICE The casing to pipe adapter with wood ring, protects the leading product pipe surface. On long runs or collapsing soil, fluid can be connected to this adapter to lower jacking pressures by lubricating the outside diameter of the product pipe.



4. Secure pipe adapter to casing with four keepers.

NOTICE Be sure wood ring or other means of cushioning the pipe is installed in the pipe adapter to protect the product pipe while jacking. Failure to do so will cause pipe damage or breakage.



(continued on next page)

NOTICE

When advancing PCH or product pipe, ALL FOUR thrust block assembly wheels MUST be contacting the jacking frame rails. Failure to do so will result in wheel bearing failure. If this misalignment occurs, the GBM frame must be readjusted so the frame is on the same line and grade as the PCH/product pipe.

⚠ WARNING

Suspended loads may fall and cause severe personal injury or death. Do not stand or walk under a load.

5. Lower product pipe into launch shaft with the bell end of the product pipe away from the reception shaft.
6. Carefully align product pipe into the pipe adapter.
7. Align product pipe onto pipe thrust adapter.

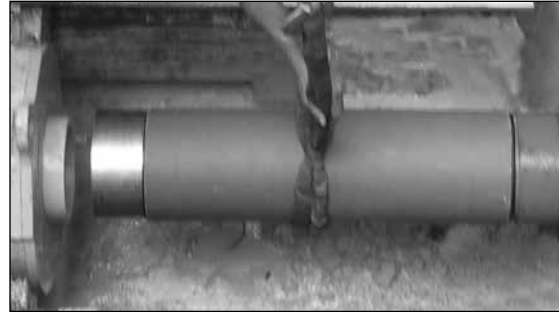

8. Push product pipe into pipeline with the thrust cylinder control.

NOTICE

To properly support the product pipe be sure to use the bottom roller bracket, located on the front of frame extension rails.

9. Continue to add new sections of product pipe until the product pipe reaches the reception shaft.
10. With the addition of each section of product pipe, a section of casing/auger is removed from the reception shaft.
11. Using a hoist to keep the casing/auger in line with the pipeline, remove keepers from the casings.



NOTICE

Remove bottom keepers first, otherwise the weight of the casing and auger will make it difficult to remove the bottom keepers once the top keepers are removed.



12. Slide the lead casing out to gain access to the auger joint.



(continued on next page)

13. Disconnect the augers by removing the auger bolt and nut that was installed in the launch shaft (back bolt as shown or bolt located towards launch shaft).



⚠ WARNING Auger may fall out of casing and cause severe injury or death if casing tips or hits an obstruction. Properly install safety chain assembly or casing auger pin to augers and casings before lowering into or lifting out of shaft. Do not stand or walk under a load.

14. Slide the front auger into the lead casing. Secure auger to casing with safety chain assembly or auger pin.
15. Remove auger casing from reception shaft.
16. Continue removing auger casings until the product pipe reaches the reception shaft. Remove the casing to pipe adapter from the product pipe.



Operation - Miscellaneous

PILOT TUBE PULL BACK THROUGH LAUNCH SHAFT

1. Secure pullback coupler around drive adapter swivel adapter and thrust block shaft with four 1/2-13 UNC x 1.25 socket head cap screws.
2. With the pilot tube engaged (locked) into the make-up tool, just thread the drive adapter swivel into the pilot tube but do not torque, by slowly rotating the drive swivel in the clockwise (CW) direction with the drive rotation control and thrust cylinder control.

NOTICE Since the drive swivel is now secured to the thrust plate, there is no “free-play” in the drive during the threading of the pilot tube. The thrust plate must be advanced/retracted at the same rate as the pilot tube is rotated in or out. Otherwise, thread damage will occur.

NOTICE Slide pilot tube wiper onto pilot tube if needed to remove soil accumulated on the outside of pilot tube.

NOTICE Threading of the pilot tubes will be more difficult than normal. There is no play in the swivel motion front to back. Cylinder travel will have to be carefully controlled with rotation and thrust cylinder control so the make-up tool is held in place. It is possible to pull the make-up tool off its mounting.

3. Disengage make-up tool and pull back pilot tube until the notches of the next pilot tube align with make-up tool by using the thrust cylinder control. It may be necessary to remove soil from tubes to find notches for the make-up tool.

4. Engage make-up tool into pilot tube notches.
5. Install launch shaft breakout tool over notches on the pilot tube and drive swivel.

(continued on next page)

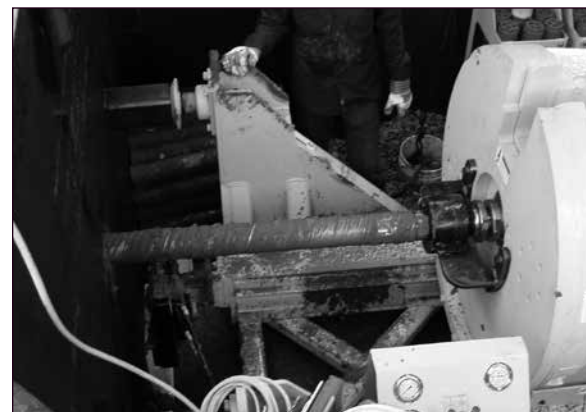
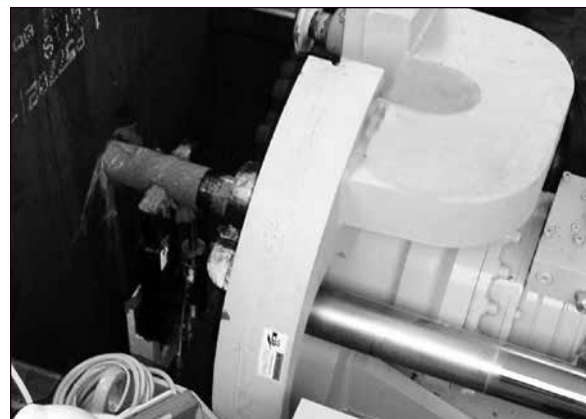

⚠WARNING Flying breakout tool can cause serious personal injury or death. BEFORE loosening (breaking) joint, the tool chain MUST be fastened around pilot tube and swivel.

6. Fasten breakout tool chain around pilot tube and swivel.



7. With the pilot tube locked into the make-up tool, loosen the pilot tube joints by rotating the drive swivel counterclockwise (CCW) with the drive rotation control.



8. Once the joint has been loosened, remove the breakout tool.



9. Remove pilot tube. Install caps and plugs on pilot tube and store on pilot tube rack.
10. Continue to pull back pilot tubes as needed with steps 2 through 9.



Transporting

TRANSPORTING GUIDELINES



1. Know the local, state, and federal transportation regulations.
2. Obtain required permits for transporting.
3. Remove any obstacles from the trailer floor.
4. Clean ALL debris from machine.
5. Load and unload on level ground.
6. Use shipping straps to fasten the guided boring machine and power pack to trailer floor.

NOTES

Fuels & Lubricants

NOTICE

Use of inferior fuels or lubricants can affect the efficient performance of your Akkerman Guided Boring Machine. Always use high quality fuel and lubricants as specified in this section.

FUEL SPECIFICATIONS

NOTICE

For more information on maintaining your fuel and additional fuel specifications, refer to your Deere engine manual.

Diesel fuels specified to EN 590 or ASTM D975 are recommended.

The fuel must meet the following properties:

- Cetane number of 45 minimum
- Cold Filter Plugging Point below the expected low temperature OR Cloud Point at least 9° F (5° C) below the expected low temperature.
- Fuel lubricity should pass a minimum of 3100 gram load level as measured by the BOCLE scuffing test.
- Do not use diesel fuel with sulfur content greater than 1.0%. Sulfur content less than 0.05% (500 ppm) is preferred.
- Bio-diesel fuels may be used ONLY if the fuel properties meet DIN 51606 or equivalent specification.
- DO NOT mix used engine oil or any other type of lubricant with diesel fuel.



ENGINE OIL - P275T

The power pack engine is filled with SAE 10W30 break-in oil.

Change the oil and filters after first 100 hours (maximum) operation and every 500 hours thereafter.

After the first 100 hours of operation, use oil viscosity based on the expected air temperature range during the period between oil changes as shown in chart.

Multi-Viscosity diesel engine oils are preferred.

Other oils may be used if they meet one or more of the following:

- API Service Classification CH-4
- API Service Classification CG-4
- API Service Classification CF-4
- ACEA Specification E3
- ACEA Specification E2

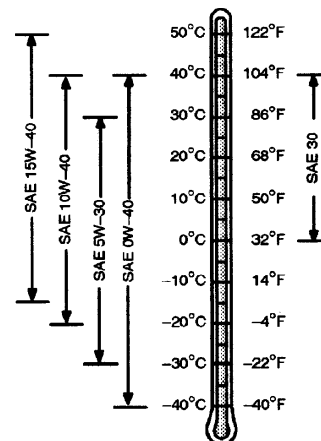
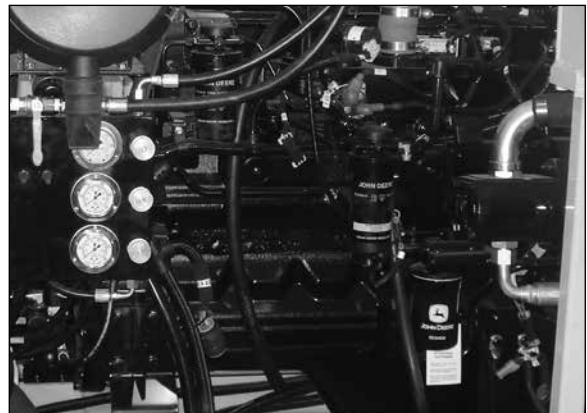

ENGINE OIL - P150Q

NOTICE

For more information on the engine oil specifications, refer to your engine manual.

The power pack engine is filled with SAE 10W30 break-in oil.

Change the oil and filters after first 100 hours (maximum) operation.

After the first 100 hours of operation, use oil viscosity based on the expected air temperature range during the period between oil changes as shown in chart.

Multi-Viscosity diesel engine oils are preferred.

Other oils may be used if they meet one or more of the following:

- API Service Category CJ-4
- API Service Category CI-4 PLUS
- API Service Category CI-4
- ACEA Oil Sequence E5
- ACEA Oil Sequence E4

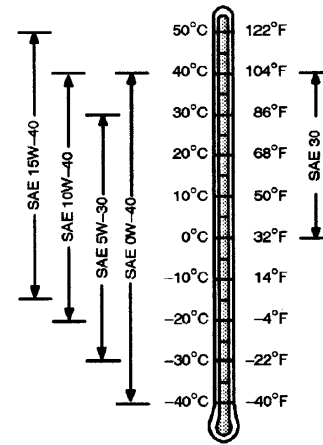

POWER PACK HYDRAULIC OIL RESERVOIR LUBRICANT

The power pack oil reservoir is typically filled with ISO-VG-46 20W Premium Hydraulic/Turbine Oil.

Use an API GL-1/GL-2 or equivalent when adding or changing lubricant.

NOTICE

If using a too heavy of viscosity oil in cold temperatures, hydraulic oil pump damage could result due to pump cavitation. On the contrary, using ISO 32 or 46 oils above 150°F operating temperatures (oil temp. in reservoir) will result in reduced hydraulic power to functions.

Recommended hydraulic oil:

Ambient Temp.	Hydraulic Oil
-25°F to 60°F (-32°C to 16°C)	ISO 32
0°F to 95°F (-18°C to 35°C)	ISO 46
32°F to 105°F (-0°C to 41°C)	ISO 68



P275T Shown

NOTICE

If you change to a different oil, use a reputable oil supplier to meet or exceed the ISO-VG-46 20W or API GL-1/GL-2 oil specification. Do not mix oil manufacturers or grades.

AUGER DRIVE LUBRICANT

The auger drive is filled with Mobil SHC 630 Synthetic Bearing and Gear Oil.

Use Mobil SHC 630 or equivalent when adding or changing lubricant. Do not mix oils.

NOTICE

The Mobil SHC 630 Synthetic Bearing and Gear oil is a synthetic oil specifically designed for this application. If you change to a different oil, use a reputable oil supplier to meet or exceed the Mobil SHC 630 oil specification. Do not mix oil manufacturers or grades.



4812A SN 1 - 3 Shown

GREASE

The lubrication points are greased with Mobilgrease® XHP222 Premium Lubricating Grease.

The XHP222 grease is a multi-purpose, high performance, high temperature, lithium grease.

Use Mobilgrease® XHP222 Premium Lubricating Grease or equivalent when lubricating the lubrication points (A).

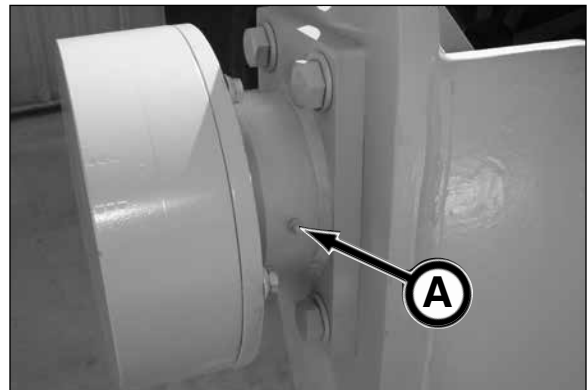

BREAKOUT TOOL POWER UNIT LUBRICANT

The breakout tool power unit oil reservoir is filled with ISO-VG-46 20W Premium Hydraulic/Turbine Oil.

Use an API GL-1/GL-2 or equivalent when adding or changing lubricant.

NOTICE

If you change to a different oil, use a reputable oil supplier to meet or exceed the ISO-VG-46 20W or API GL-1/GL-2 oil specification. Do not mix oil manufacturers or grades.



ENGINE COOLANT

⚠ WARNING Cooling system under pressure. Explosive release of HOT engine coolant can cause severe burns. SLOWLY remove the radiator cap ONLY if the engine is cool.



The engine radiator coolant is a 50% mixture of ethylene glycol engine coolant and distilled, deionized, or demineralized water.

This mixture provides protection against corrosion and cylinder liner pitting, and winter freeze protection to -34°F (-37°C). If protection at lower temperatures is required, contact your engine dealer for recommendations.

NOTICE Refer to your engine manual for information on using a Supplemental Coolant Additive (SCA) in your cooling system.



NOTICE Do not use cooling system sealing additives or antifreeze that contain sealing additives.

POWERED CUTTER HEAD BEARING CAVITY & GEAR BOX LUBRICANT

The powered cutter head front section bearing cavity and rear section auger drive gear box are filled with Mobil SHC 630 Synthetic Bearing and Gear Oil.

Use Mobil SHC 630 or equivalent when adding or changing lubricant.

NOTICE The Mobil SHC 630 Synthetic Bearing and Gear oil is a synthetic oil specifically designed for this application. If you change to a different oil, use a reputable oil supplier to meet or exceed the Mobil SHC 630 oil specification. Do not mix oil manufacturers or grades.



INTEGRAL BEARING SWIVEL CUTTER HEAD BEARING CAVITY LUBRICANT

The bearing swivel bearing cavity is filled with Mobilgear® 600 XP 680 (formerly Mobilgear 636) Gear Oil.

Use Mobilgear® 600 XP 680 or equivalent when adding or changing lubricant.

NOTICE

The Mobilgear 600 XP 680 Gear oil is an extra high performance gear oil having extreme pressure characteristics and load carrying properties, intended for use in all types of enclosed gear drives. If you change to a different oil, use a reputable oil supplier to meet or exceed the Mobilgear 600 XP 680 gear oil specification. Do not mix oil manufacturers or grades.

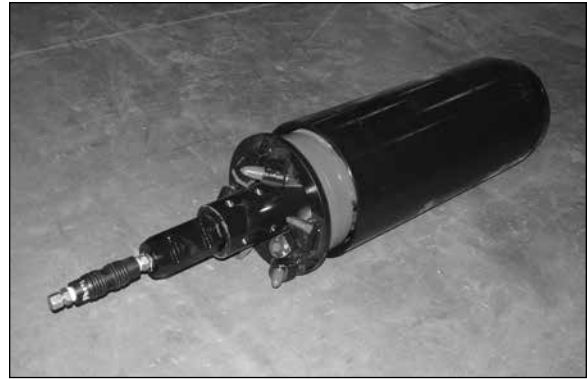

STORING LUBRICANTS

Your equipment can operate at maximum performance only if clean lubricants are used. Use clean containers to handle all lubricants. Hydraulic contaminants can be smaller than is visible with the eye. Be sure containers for hydraulic oil are CLEAN.

Lubricants should be stored in an area protected from dust, moisture, and other contaminants.



NOTES

Periodic Maintenance

⚠ WARNING Review the Safety section in this manual before performing maintenance. Failure to do so, could cause severe injury or death.

LUBRICATION & MAINTENANCE INTERVALS

The requirements for lubrication and maintenance are shown on the maintenance charts in this section. Intervals of maintenance are based on normal operating conditions. If operating under more difficult conditions, use a shorter time interval between maintenance.

Use the hour meter (A) on the power pack control pendant to determine the proper lubrication and maintenance intervals.

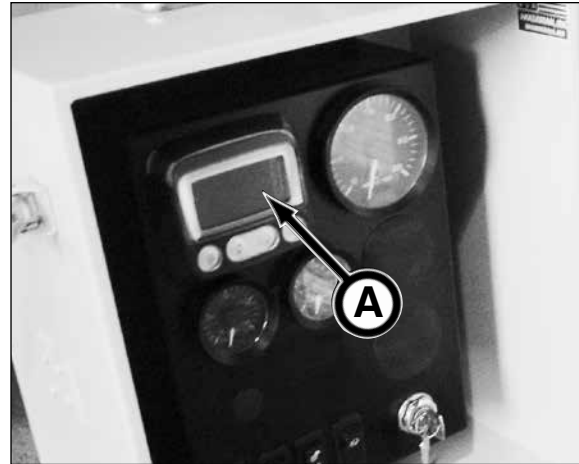

Power Pack Pendant

LOCKOUT POWER BEFORE SERVICING

⚠ WARNING Severe personal injury or death can result from unexpected pump unit start-up or machine movement.

LOCKOUT power before attempting to make repairs or adjustments to this equipment, unless otherwise indicated. Proper lockout will prevent accidents and save lives. Performing the lockout will also prevent the equipment from moving or operating unexpectedly.



AVOID PINCH POINTS

⚠ WARNING Moving parts or the mishandling of parts can cause severe personal injury.

Keep hands away from moving parts.

Watch your fingers, hands, and legs while equipment is in operation.

Handle parts carefully to avoid crushing and pinch point hazards.

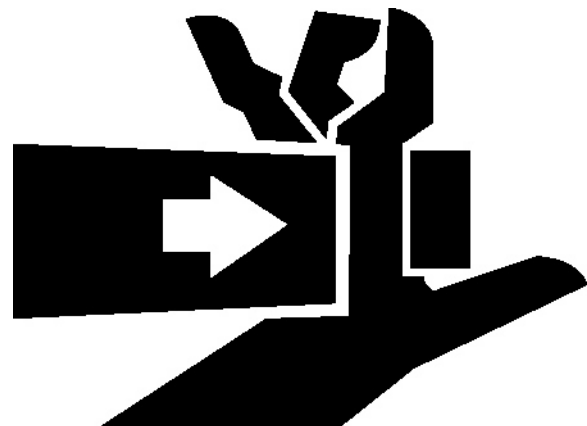

INSTALL CYLINDER STOPS PRIOR TO MAINTENANCE

⚠WARNING Crushing hazard.

BEFORE setting up theodolite or performing maintenance in the rear area of the 4812A frame, the cylinder stops (A) must be placed on cylinder rods. Failure to do so can result in serious personal injury or death.

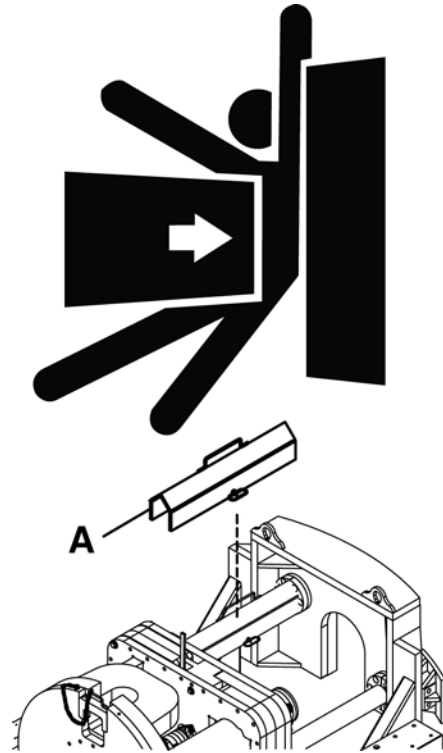

HYDRAULIC OIL/FLUIDS UNDER PRESSURE

⚠WARNING Escaping oil or other fluids under pressure can penetrate your skin causing serious injury.

Release all pressure before performing maintenance or repairs. Never weld near pressurized fluid lines.

DO NOT use your hands to check for leaks. When searching for leaks, use a piece of wood or cardboard.

Contact medical help immediately if any oil or fluid is injected into your skin. A serious infection or reaction can emerge without proper medical treatment.



MAINTENANCE CHARTS - 4812A - P275T - P150Q

Use the item number in the chart to refer to the detailed maintenance procedures later in this section.

NOTICE

For Powered Cutter Head maintenance, refer to Powered Cutter Head Maintenance later in this section.

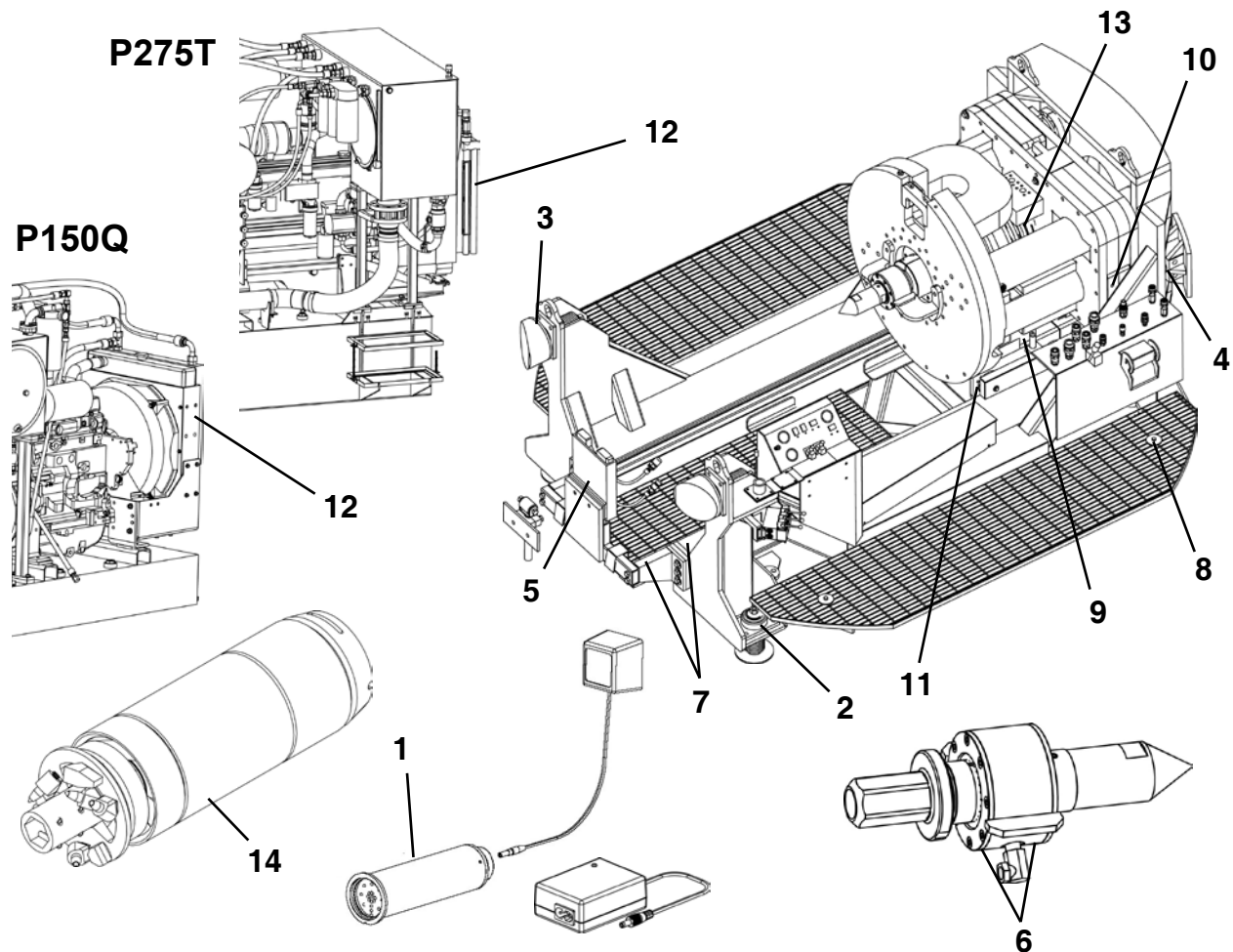

PRIOR TO EACH JOB LAUNCH

ITEM	COMPONENT	SERVICE	REQUIREMENT	MATERIAL
1.	Target	Charge/Replace Battery	Charge 24 hours prior to operation.	
2.	Leveling Assembly	Lubricate (4 places)	Lubricate until grease is forced out.	Mobil XHP222
3.	Front Anchor Block	Lubricate (2 places)	Lubricate until grease is forced out.	Mobil XHP222
4.	Rear Pivot Pad*	Lubricate (2-4 places)	Lubricate until grease is forced out.	Mobil XHP222
5.	Hydraulic Make-Up Tool	Clean		
6.	Drive Adapter/Swivel	Lubricate (2 places)	Lubricate with 3 to 5 shots.	Mobil XHP222
7.	Frame Rails	Clean		
8.	Operator Platform	Inspect & Secure Hardware		
9.	Push Plate Brake Cyl. Locking Pin	Lubricate	Lubricate with 2 shots.	Mobil XHP222
10.	Latching Mechanism	Lubricate (8 places)	Lubricate with 3 shots.	Mobil XHP222
11.	Wheel Bearings	Lubricate (8 places)	Lubricate until grease is forced out.	Mobil XHP222
12.	Radiator/Oil Cooler	Clean	As needed.	
13.	Rear Motor Seal	Lubricate (SN 1 - 3 only)	Lubricate until grease is forced out.	Mobil XHP222
14.	Bearing Swivel	Check Lubricant Level	Bottom of check port level.	Mobilgear 600 XP680
**14.5	Theodolite	Check	Perform Checking Zero Point Calibration Procedure	

* Round Shaft Pads - 4 places, Square Shaft Pads - 2 places ** Not Shown

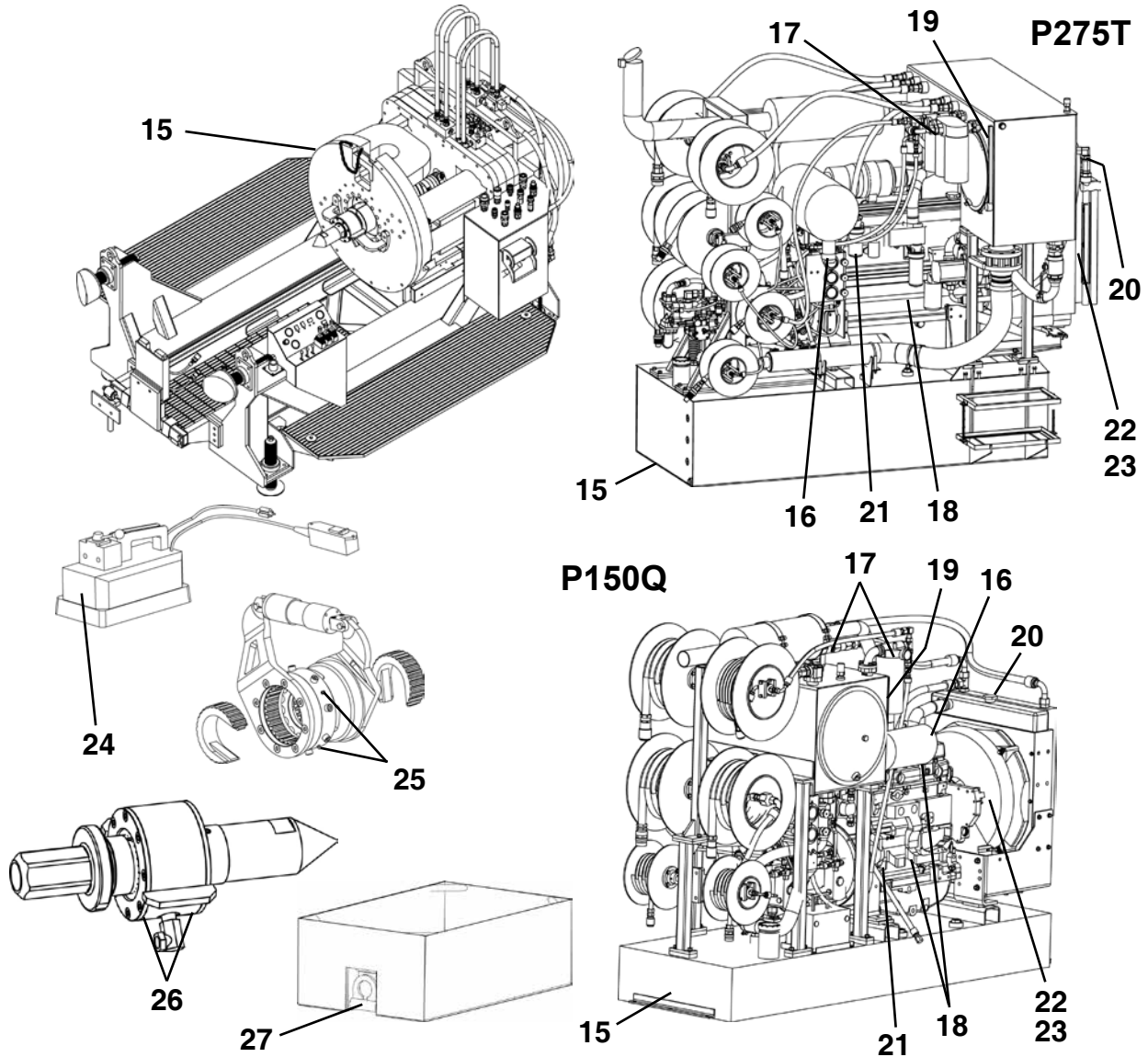

***DAILY OR EVERY 10 HOURS OF OPERATION**

ITEM	COMPONENT	SERVICE	REQUIREMENT	MATERIAL
15.	GBM & Power Pack	Visual Inspection	If parts are damaged or missing, replace.	
16.	Air Cleaner Dust Unloader	Clean Out		
17.	Hydraulic Return Filters	Check Indicator	Replace filter as needed per indicator.	Return Filter
18.	Engine Crankcase**	Check Oil Level	Add oil as needed.	See Section 8
19.	Hydraulic Reservoir	Check Fluid Level	Add hydraulic fluid as needed.	ISO-VG-46 20W
20.	Radiator	Check Coolant Level	Add coolant as needed.	
21.	Fuel/Water Separator	Drain Water	Drain until fuel is visible.	
22.	Fan	Inspect Fan & Guard	If damaged, replace with new.	
23.	Belt	Inspect	If damaged, replace with new.	
24.	Breakout Tool	Check Oil Level	Add oil as needed.	ISO-VG-46 20W
25.	Breakout Tool	Lubricate (4 places)	Lubricate 2 shots per fitting.	Mobil XHP222
26.	Drive Adapter/Swivel	Lubricate (2 places)	Lubricate with 3 to 5 shots.	Mobil XHP222
27.	Dirt Bucket Lift Eye	Lubricate	Lubricate until grease is forced out.	Mobil XHP222

* Refer to your engine manual for additional engine maintenance information.

** During engine break-in period, change the oil and filter for the first time before 100 hours of operation.

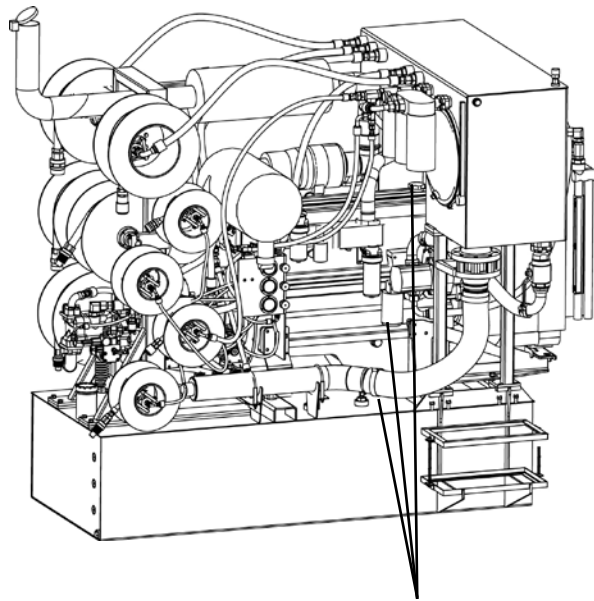

P275T

28

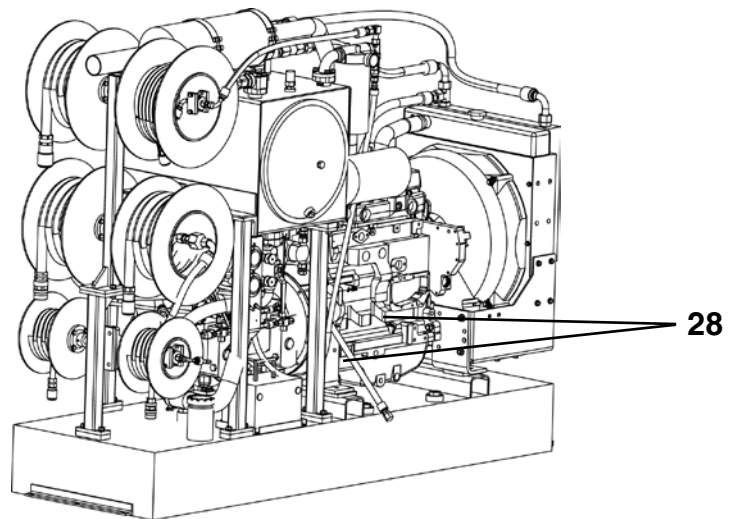

P150Q

28

***FIRST 100 HOURS OF OPERATION & EVERY 500 HOURS THEREAFTER**

ITEM	COMPONENT	SERVICE	REQUIREMENT	MATERIAL
28.	Engine Oil/Filter	Drain & Replace	Replace with new oil & filter.	See Section 8

* Refer to your engine manual for additional engine maintenance information.

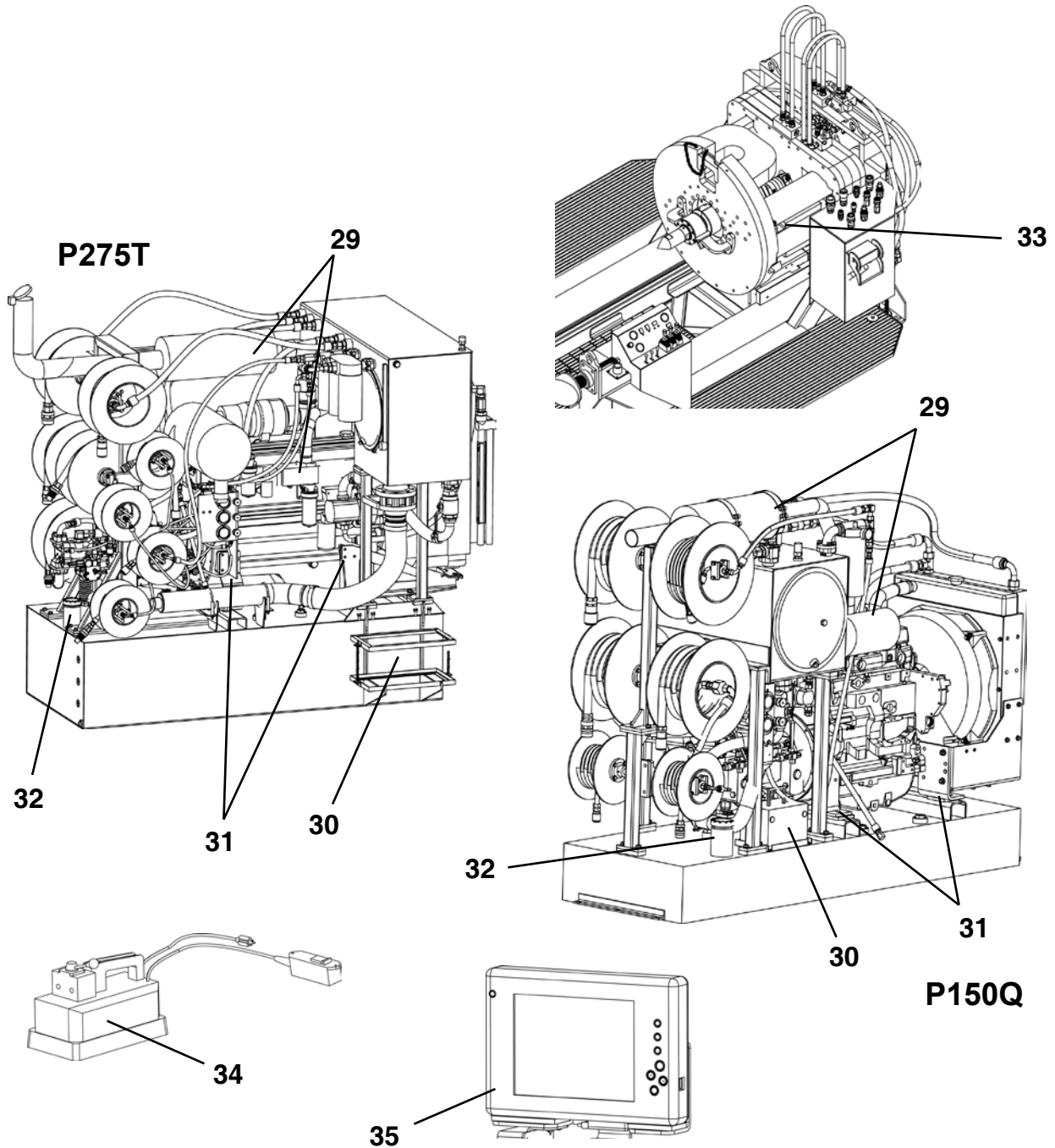

***MONTHLY OR EVERY 250 HOURS OF OPERATION**

ITEM	COMPONENT	SERVICE	REQUIREMENT	MATERIAL
29.	Air Intake & Exhaust System	Inspect All Connections	Repair or replace as needed.	
30.	Battery	Inspect	Check for damage or frayed cables.	Battery/Cable
31.	Engine Mounts	Inspect	Replace as needed.	
32.	Fuel Tank Cap	Inspect & Clean	Replace if damaged.	
33.	Auger Drive	Check Oil Level	Add oil as needed.	Mobil SHC 630
34.	Breakout Tool Power Unit	Drain, Flush & Refill Reservoir	Refill to top of filler hole.	
35.	Tablet PC	Charge Battery		

* Refer to your engine manual for additional engine maintenance information.

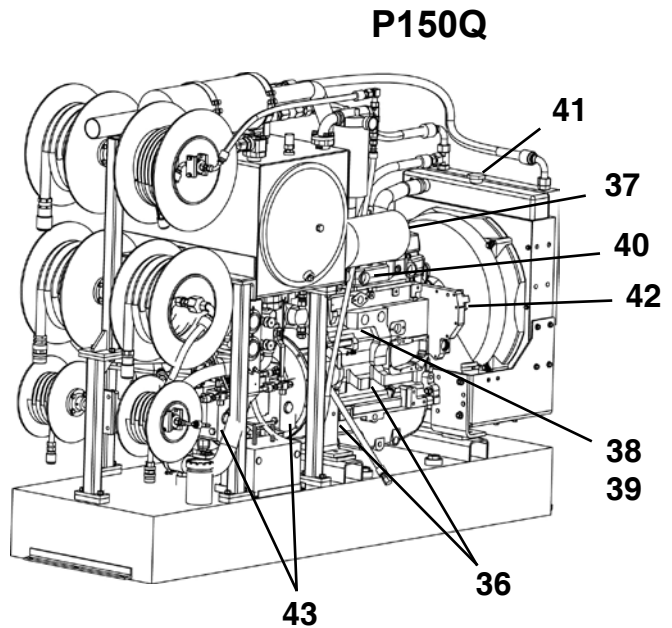
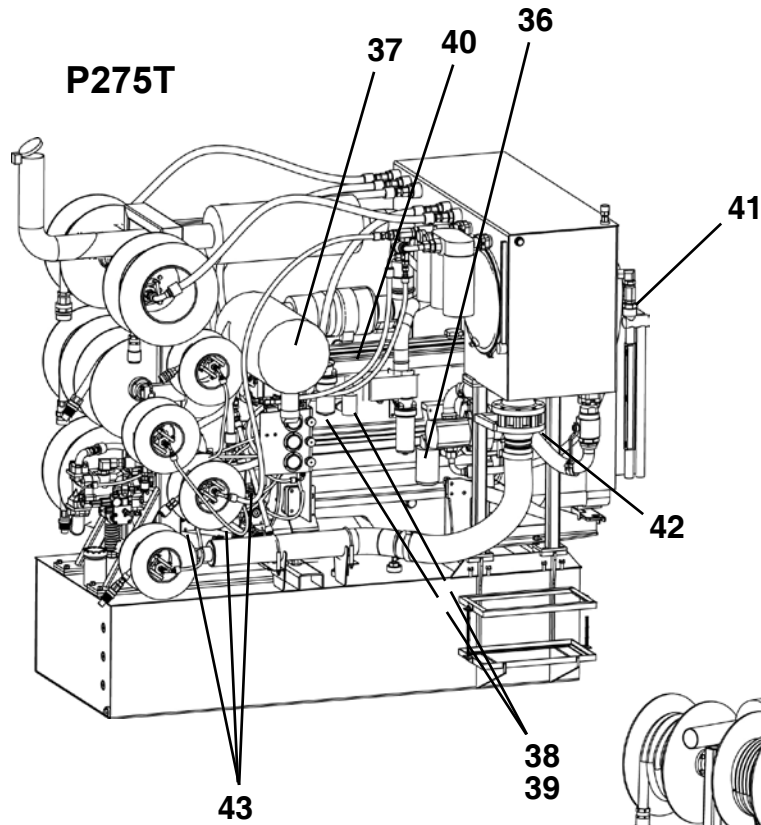

***EVERY 500 HOURS OF OPERATION**

ITEM	COMPONENT	SERVICE	REQUIREMENT	MATERIAL
36.	Engine Oil/Filter	Drain & Replace	Replace with new oil and filter.	See Section 8
37.	Air Cleaner	Install New		Element(s)
38.	Fuel System	Replace Fuel Filters		Fuel Filters
39.	Fuel System	Bleed Fuel System	See engine manual.	
40.	Crankcase Vent Tube	Clean		
41.	Cooling System	Check	Coolant touches bottom of filler neck.	Water/Anti-Freeze
42.	Belt & Belt Tensioner	Check		
43.	Load Sense Filters	Replace	Replace with new.	LS Filters

* Refer to your engine manual for additional engine maintenance information.

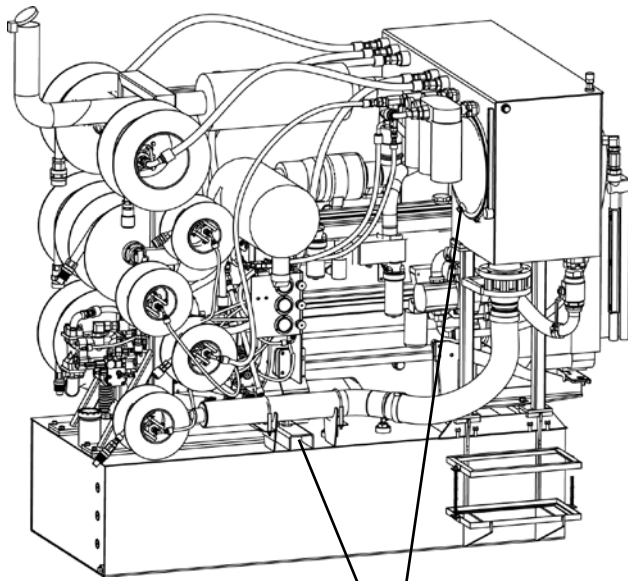

P275T

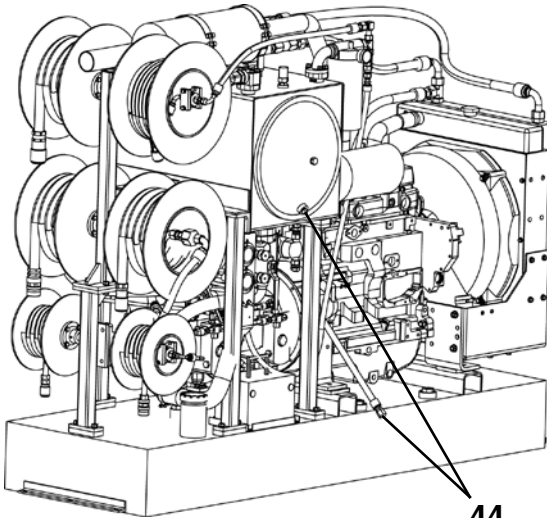
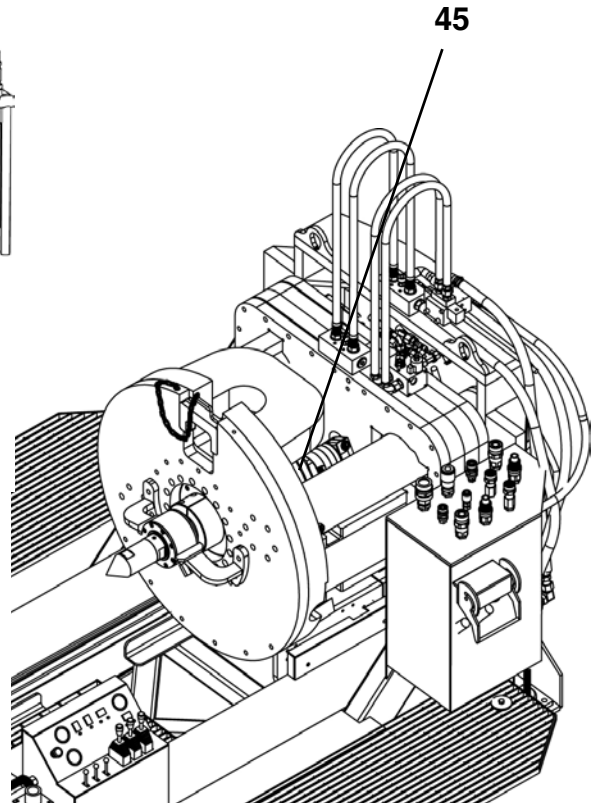

P150Q

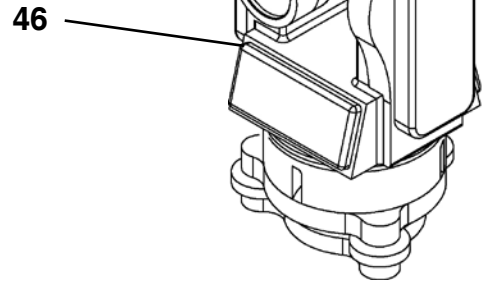

***EVERY 1000 HOURS OF OPERATION**

ITEM	COMPONENT	SERVICE	REQUIREMENT	MATERIAL
44.	Hydraulic Reservoir	Drain & Fill	Drain and fill with new oil.	ISO-VG-46 20W
45.	Auger Drive	Drain & Fill	Drain and fill with new oil.	Mobil SHC 630
46.	Theodolite	Recalibrate	Send to authorized service center.	

* Refer to your engine manual for additional engine maintenance information.

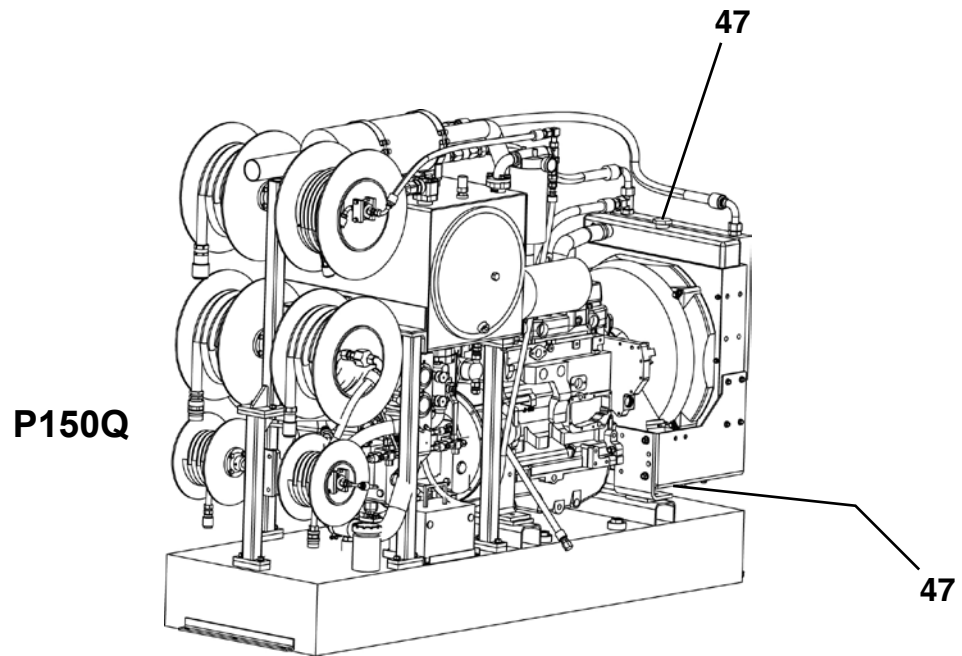
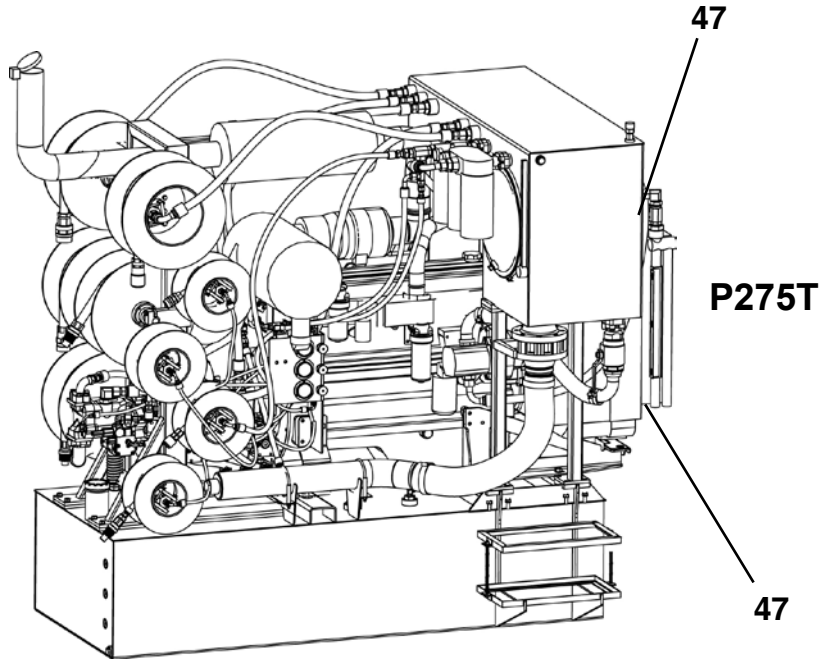

***EVERY 2000 HOURS OF OPERATION**

ITEM	COMPONENT	SERVICE	REQUIREMENT	MATERIAL
47.	Cooling System	Flush & Fill	Refer to engine manual.	Water/Anti-Freeze

* Refer to your engine manual for additional engine maintenance information.

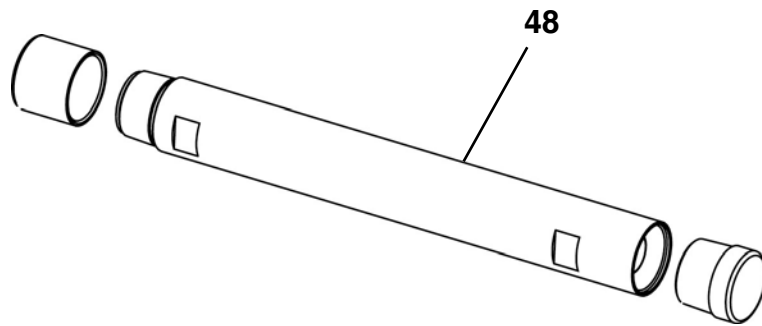

AFTER EACH DRIVE

ITEM	COMPONENT	SERVICE	REQUIREMENT	MATERIAL
48.	Pilot Tubes	Clean	Clean inner tube & annular space.	

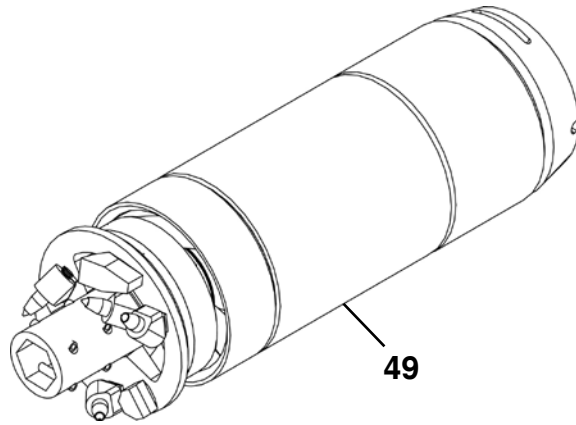

AFTER EVERY 2000 FEET

ITEM	COMPONENT	SERVICE	REQUIREMENT	MATERIAL
49.	Bearing Swivel	Drain & Fill	Fill with new oil.	Mobilgear 600 XP 680

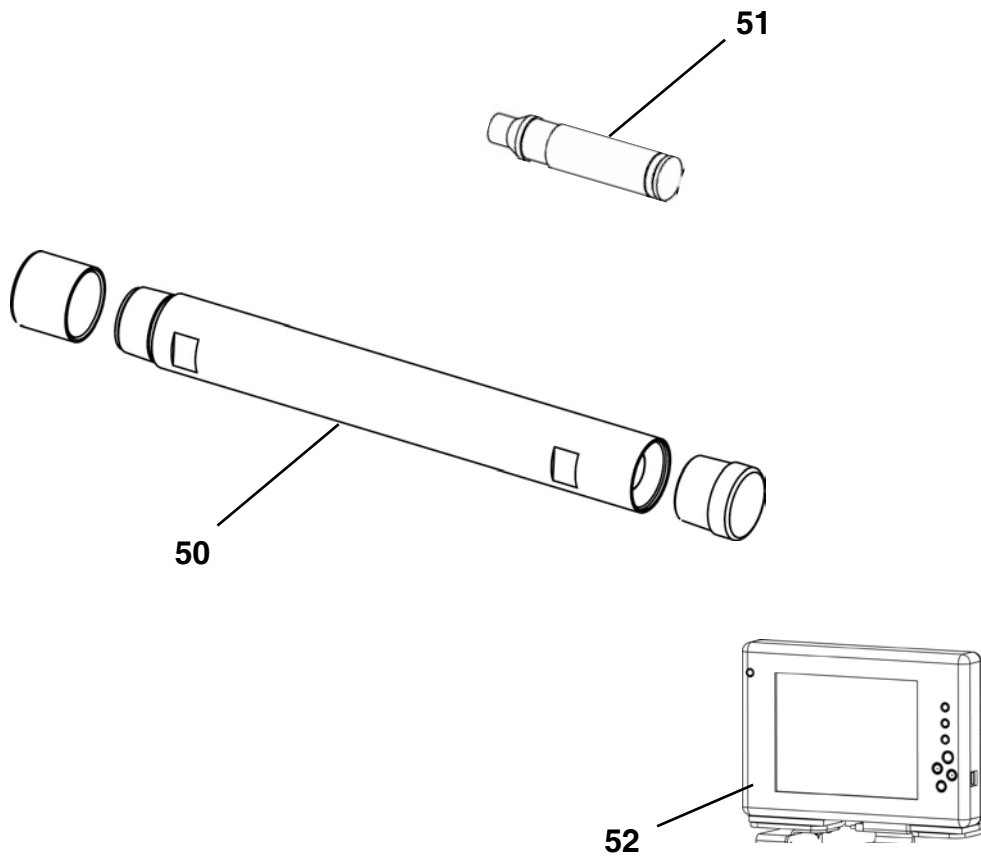

AS REQUIRED

ITEM	COMPONENT	SERVICE	REQUIREMENT	MATERIAL
50.	Pilot Tube Threads	Inspect & clean	Clean & Relubricate Threads	See Detail
51.	Laser Bore Sight	Replace batteries	Three 392 Button Batteries	Button Batteries
52.	Tablet PC	Charge Battery		

PRIOR TO EACH JOB LAUNCH

1. CHARGE TARGET LED BATTERY OR REPLACE D-SIZE ALKALINE BATTERIES

There are two target configurations; rechargeable NiCd battery target with an overnight charger and/or smart charger, and a replaceable battery target.

CAUTION Use charger only in a dry location to prevent the risk of electric shock.

When using the overnight charger (A), recharge target NiCd batteries by connecting the AC adapter to the target and plugging the AC adapter into a 120V outlet. Charge for 8-10 hours before operation. The battery should last for 7 days on a full charge. Do not repeatedly over charge the target battery, otherwise the battery life will decrease.

NOTICE With the overnight charger, it is best to discharge the batteries fully before recharging due to the “memory” effect of NiCd batteries. If battery charge life appears to be shortened, repeat the fully discharge, fully charge cycle a few times to update the memory in the battery. If battery life continues to be short, dispose of battery properly. Refer to the charger User Manual or contact your Akkerman product support representative for more information.

NOTICE The smart charger (B) drains the battery, recharges, and does not over charge the battery. A full charge takes approximately 3 hours. *The smart charger will not charge a completely drained battery.* Refer to the charger User Manual or contact your Akkerman product support representative for more information.

The replaceable battery target uses two 1.5 volt, D size, Alkaline batteries (C). Do not mix manufacturers. It is recommended to replace batteries before or after each drive. The batteries should last at least 14 days.

Target ON/OFF:
 OFF - Remove batteries, replace cap.
 ON - Place batteries into target tube (as shown) and turn cap completely in to prevent moisture from entering target tube.

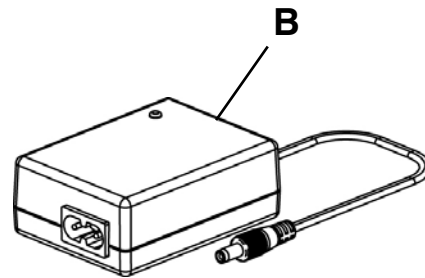
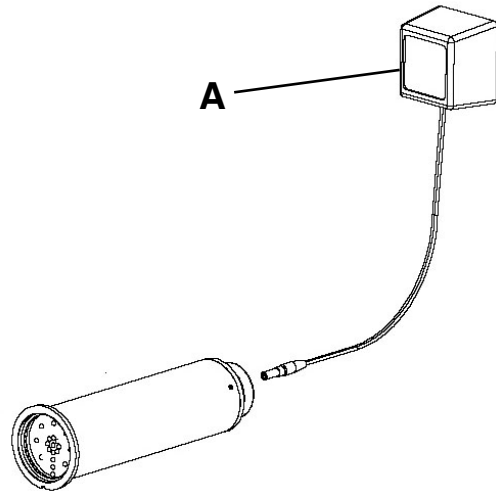

Smart Charger - Charge Cycle & LED Indications

LED	MODE
Orange	Battery Not Connected
Orange	Battery Initialization & Analysis
Red	Fast Charge
Green w/Intermittent Orange Flash	Top-Off Charge
Green	Trickle Charge
Alternating Red-Green	Error

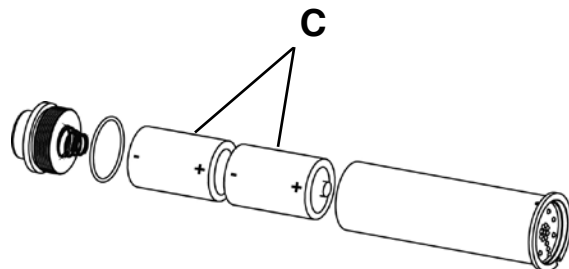

2. LUBRICATE LEVELING ASSEMBLY

Lubricate leveling assemblies (A) (4 places) with Mobilgrease® XHP222 or equivalent until grease is forced out.

Lubricate daily if subjected to water and mud. Threads must be covered from top to bottom with grease.

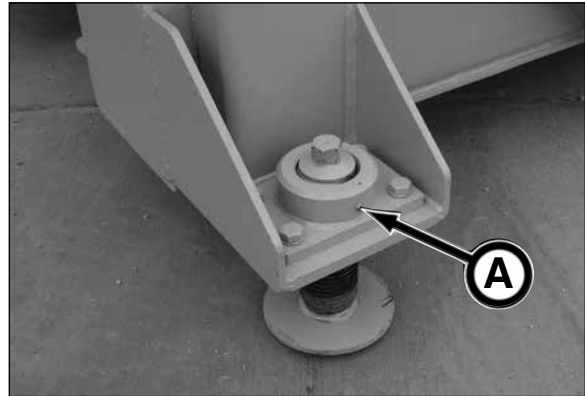

3. LUBRICATE FRONT ANCHOR BLOCK

Lubricate blocks (B) (2 places) with Mobilgrease® XHP222 or equivalent until grease is forced out.

Lubricate daily if subjected to water and mud.

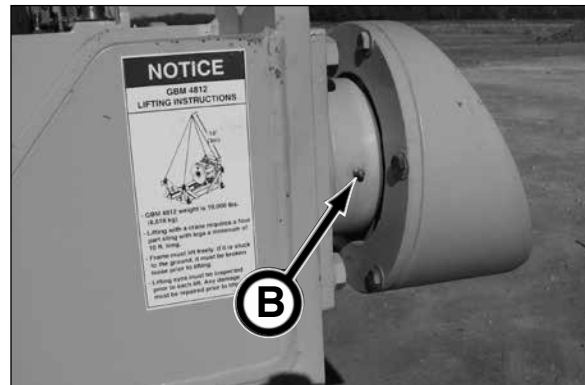

4. LUBRICATE REAR PIVOT PAD

Lubricate pivot pads with Mobilgrease® XHP222 or equivalent until grease is forced out.

The square shaft pivot pads (C) have two lubrication points.

The round shaft pivot pads (D) have 4 lubrication points.

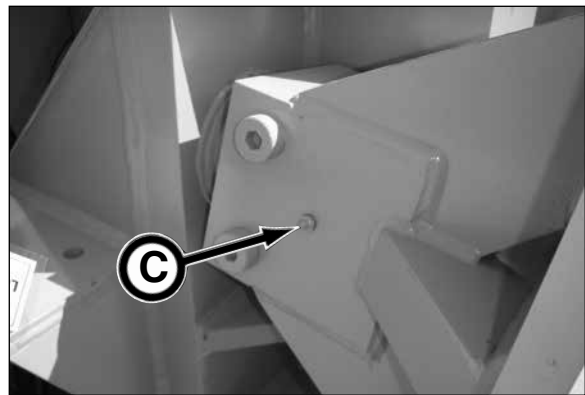

Square Shaft Pivot Pad

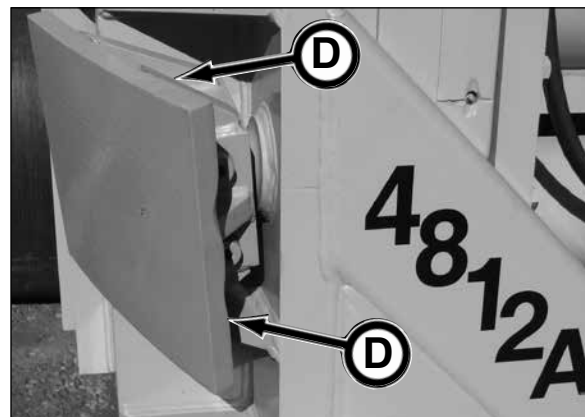

Round Shaft Pivot Pad

5. CLEAN MAKE-UP TOOL

Clean out dirt or debris from make-up tool tube support (A) and housing (B).

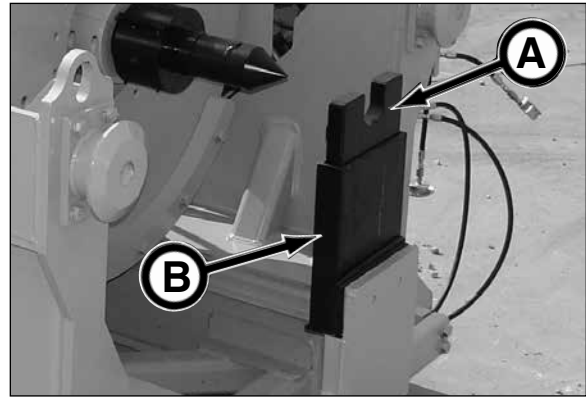

6. LUBRICATE DRIVE ADAPTER/SWIVEL

Lubricate drive adapter/swivel (C) (2 places) with 3 to 5 shots of Mobilgrease® XHP222 or equivalent.

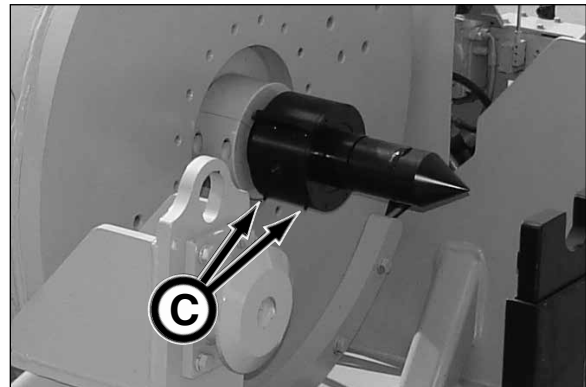

7. CLEAN & INSPECT FRAME RAILS

Clean dirt and debris from the frame rails (D). The rails must be clean during operation.

Inspect angle iron rail (E) for bending. If rail is bent, the rail must be replaced.

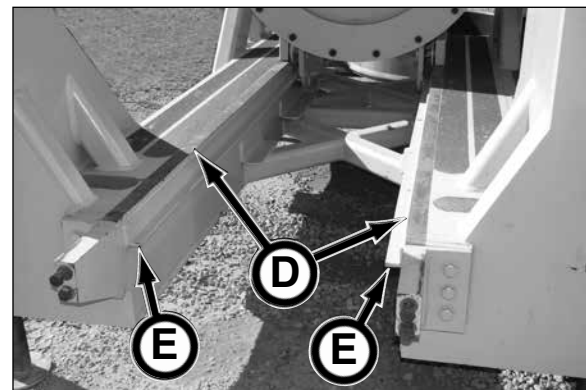

8. INSPECT OPERATOR PLATFORM

Inspect operator platform (F) for damage. Check hardware (G) for tightness.

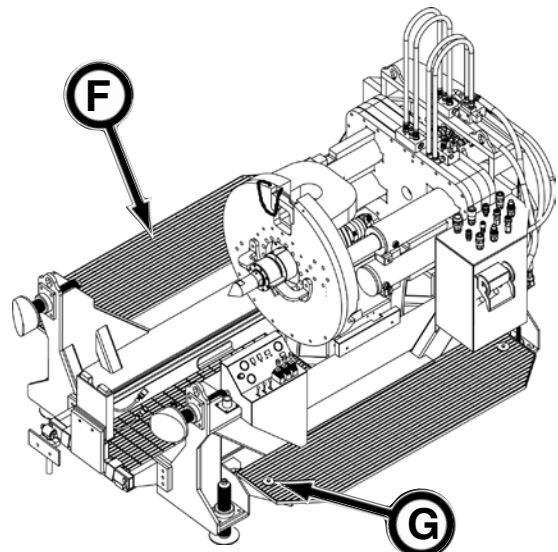

9. LUBRICATE PUSH PLATE BRAKE CYLINDER LOCKING PIN

Lubricate locking pin (A) with 2 shots of Mobilgrease® XHP222 or equivalent.

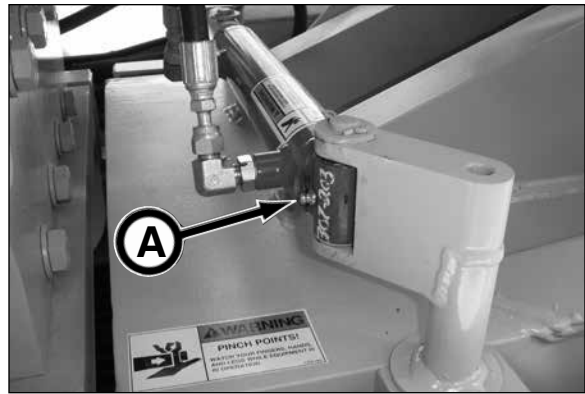

10. LUBRICATE LATCHING MECHANISM

Lubricate locking pin (B) (8 places) with 3 shots of Mobilgrease® XHP222 or equivalent.

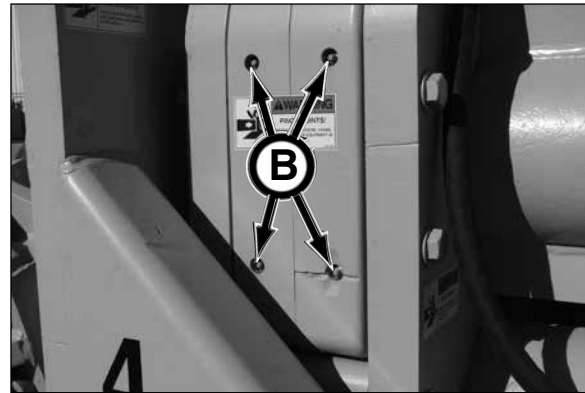

11. LUBRICATE WHEEL BEARINGS

1. Remove guards to gain access to wheel bearing lubricate points.
2. Lubricate wheel bearings (C) (8 places) with Mobilgrease® XHP222 or equivalent until grease is forced out.
3. Replace all guards.

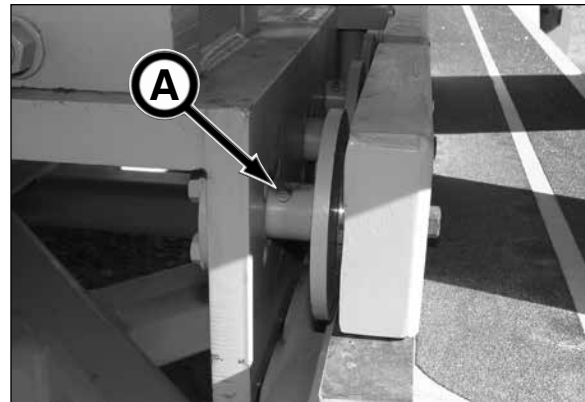

12. CLEAN RADIATOR/OIL COOLER

1. Open rear door on power pack to gain access to radiator and oil cooler (A).
2. Clean radiator / oil cooler with compressed air (100 psi maximum).



13. LUBRICATE AUGER DRIVE MOTOR SEAL (SN 1 - 3 ONLY)

Lubricate seal (B) with Mobilgrease® XHP222 or equivalent until grease is forced out.

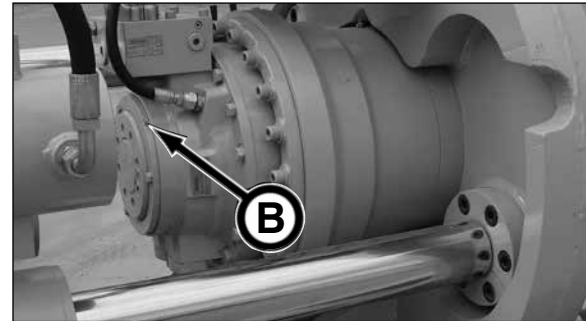

14. CHECK BEARING SWIVEL LUBE LEVEL

1. Remove swivel cutter head casing (C) to expose the auger assembly (D).
2. With the auger assembly laying down, reposition assembly with the #6 ORB check port plug (E) in the 12 o'clock position.
3. Remove the check port plug (E) on bearing housing and inspect oil level. Oil level should be at the bottom of the check port hole.
4. If oil is needed, remove the #4 NPT oil fill port plug (F) from the swivel end cap (G) and install grease fitting. Remove check port plug (E).
5. Using the oil gun (P0126-039) filled with Mobilgear 600 XP 680 Gear Oil (**DO NOT USE GREASE**), pump the gear lube until the lube is at the bottom of the check port hole.
6. Rotate swivel to work out any air and then allow the oil to settle for 10 - 15 minutes and recheck oil level.
7. Remove grease fitting installed in step 4 and reinstall the check port plug (C) and the oil fill port plug (D).
8. Cover check port plug (C) with silicone and allow to dry before use.

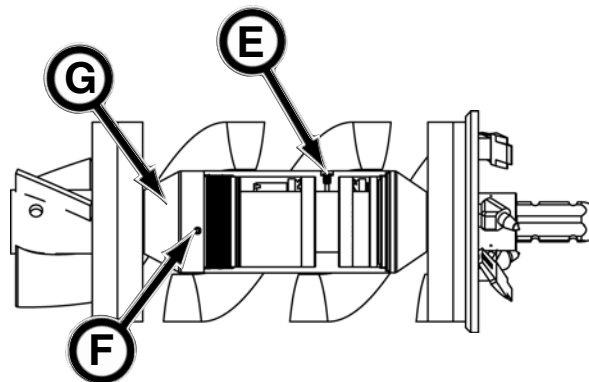
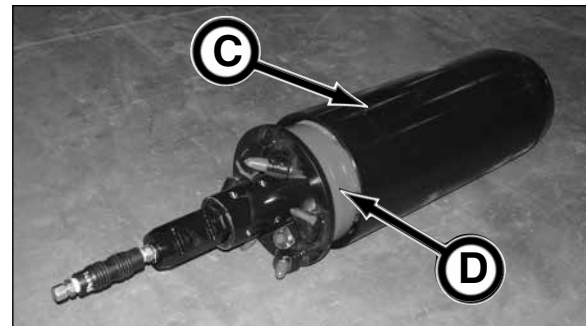

14.5 PERFORM CHECKING THEODOLITE ZERO POINT CALIBRATION

Perform Checking Theodolite Zero Point Calibration procedure in section 6, Operation of this manual.

IMPORTANT! If the stationary object is not within the theodolite cross hairs after completing the horizontal and vertical alignment steps, you must perform the "Vertical Circle Zero Point Error" procedure in accordance with the Nikon Theodolite Instruction Manual.

DAILY OR EVERY 10 HOURS OF OPERATION

15. VISUALLY INSPECT EQUIPMENT

Perform a visual inspection of the GBM and power pack. Inspect structures, cylinders, mountings and lubricant levels.

Immediately report any structural problems to your Akkerman product support representative.

Check for oil or coolant leaks, and debris buildup. Make repairs as needed and remove debris.

Check air intake and exhaust system hoses and connections. Replace any defective parts.

Check for loose, damaged, or missing parts. Repair or replace as necessary.

Tighten hardware as needed. Do not overtighten hardware.

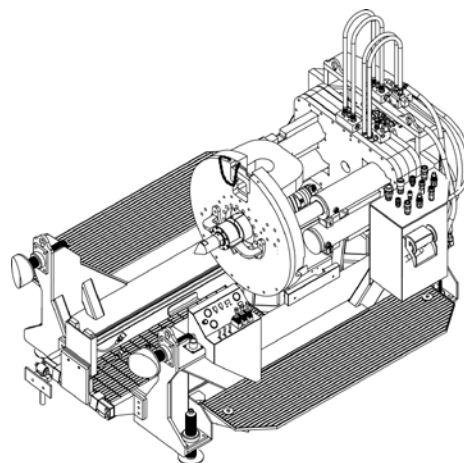

GBM 4812A Frame

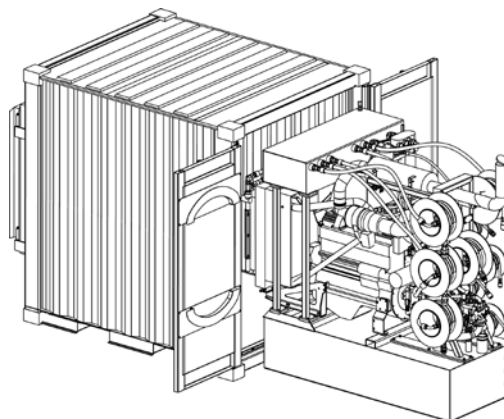

P275T Power Pack Shown

16. CLEAN OUT DUST UNLOADER VALVE

Squeeze air cleaner dust unloader valve on air cleaner assembly to release any trapped dirt particles. If the sealing tip of the valve is damaged, life of the air filter elements will be greatly reduced.



P275T Power Pack



P150Q Power Pack

17. CHECK HYDRAULIC RETURN FILTER INDICATORS - P275T

To prevent over or under servicing of the hydraulic return filters, a filter indicators (A and B) has been installed on both hydraulic return filter housings.

The green OK zone indicates that the filter is functioning properly.

The yellow zone indicates that the filter will soon require replacement.

When the needle on the gauge is in the red CHANGE zone, replace filter as soon as possible to prevent engine damage using the following procedure:

NOTICE

Check indicator with oil at operating temperature.

1. Clean and dry area around return filter.
2. Remove filter. Dispose of oil and filter properly.

NOTICE

Remove filter gasket if stuck in filter housing.

3. Fill new filter with clean hydraulic oil.
4. Lubricate new filter gasket with a light coating of clean hydraulic oil.
5. Install new filter. Hand tighten only.
6. With the hydraulic hoses disconnected from the GBM, start engine and run at low idle until the hydraulic system is warm. Then check for leaks.
7. Shut down engine.

8. Check hydraulic reservoir oil level on gauge (B). Add hydraulic oil, if necessary.

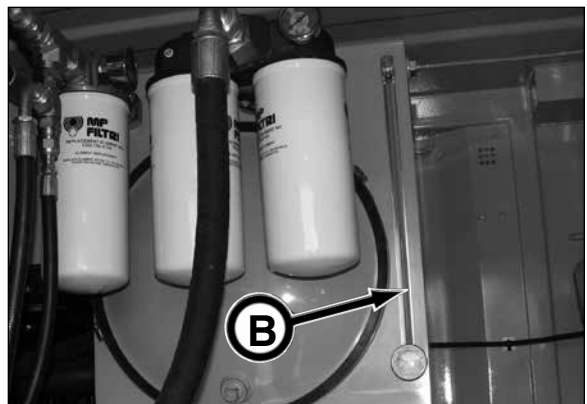

17. CHECK HYDRAULIC RETURN FILTER INDICATORS - P150Q

To prevent over or under servicing of the hydraulic return filters, a filter indicator (A) has been installed on both hydraulic return filter housings.

The green OK zone indicates that the filter is functioning properly.

The yellow zone indicates that the filter will soon require replacement.

When the needle on the gauge is in the red CHANGE zone, replace filter as soon as possible to prevent engine damage using the following procedure:

1. Clean and dry area around return filter.
2. Remove filter. Dispose of oil and filter properly.

NOTICE Remove filter gasket if stuck in filter housing.

3. Fill new filter with clean hydraulic oil.
4. Lubricate new filter gasket with a light coating of clean hydraulic oil.
5. Install new filter. Hand tighten only.
6. With the hydraulic hoses disconnected from the GBM, start engine and run at low idle until the hydraulic system is warm. Then check for leaks.
7. Shut down engine.

8. Check hydraulic reservoir oil level on gauge (B). Add hydraulic oil, if necessary.

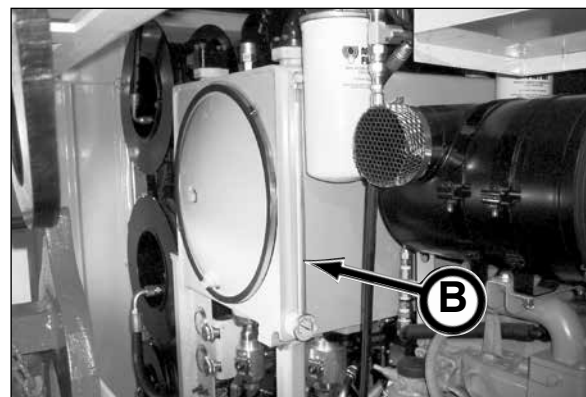
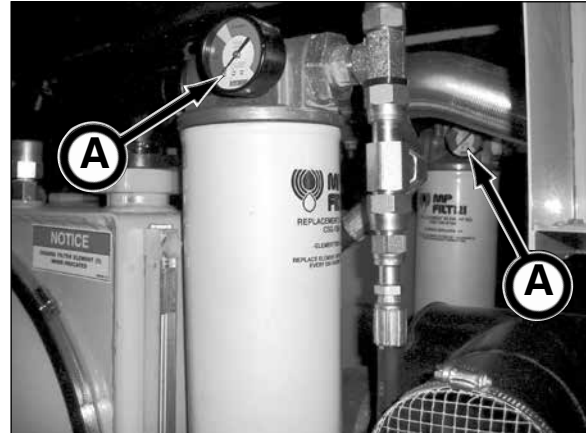

18. CHECK ENGINE CRANKCASE OIL LEVEL

Check engine oil level on dipstick. Do not fill above the top mark on the dipstick.

Oil levels anywhere within the crosshatches on the dipstick are considered in the acceptable operating range.

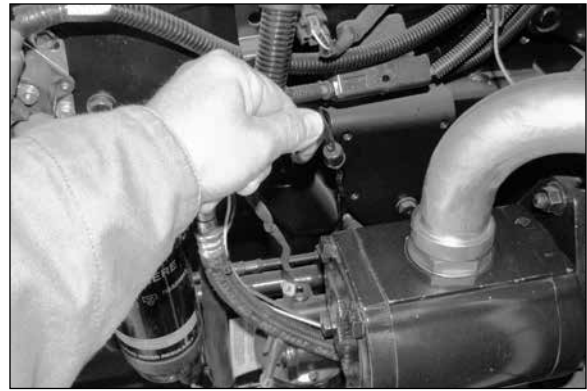

P275T



P150Q

If necessary, add engine oil. See Engine Oil in the Fuels & Lubricants section for the proper oil specification.

NOTICE

During engine break-in, change the oil and filter for the first time before 100 hours of operation.



P275T



P150Q

19. CHECK HYDRAULIC RESERVOIR OIL LEVEL - P275T

Check hydraulic tank oil level gauge (A).

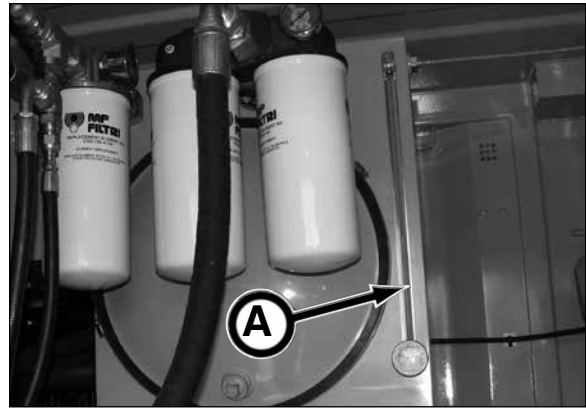

If the fluid level in the reservoir is less than 3/4 full, fill the reservoir with ISO-VG-46 20W Premium Hydraulic Turbine Oil as follows:

1. Remove hydraulic fill hose from storage location. Remove cap from hose.

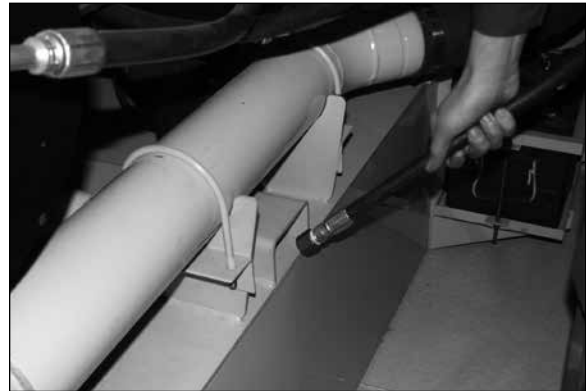

2. Place hose into hydraulic oil container.

NOTICE Refer to Fuels & Lubricants section for recommended hydraulic oil.



3. Open hydraulic fill ball valve by moving handle down to the 3 o'clock position.



(continued on next page)

4. Turn Oil Pump switch ON.

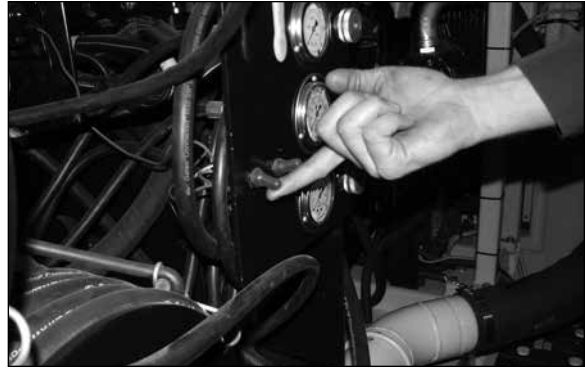

5. Fill until oil reaches the high mark on gauge (A).

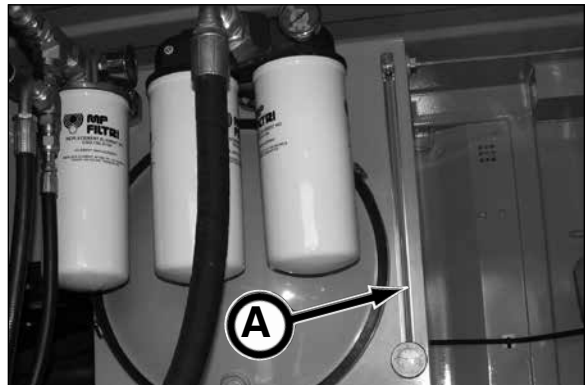

6. Turn Oil Pump switch OFF.



7. Close hydraulic ball off valve by moving the handle down to the 6 o'clock position.



8. Replace cap on fill hose and place hose in storage location.

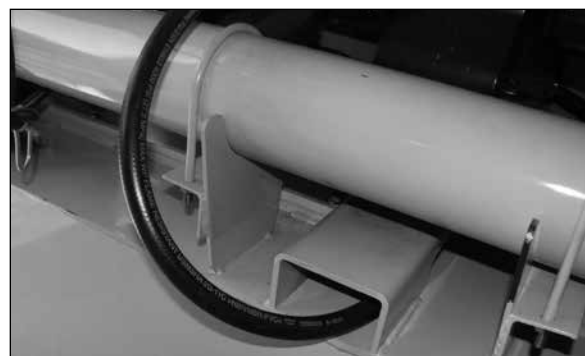

19. CHECK HYDRAULIC RESERVOIR OIL LEVEL - P150Q

NOTICE The photos in this procedure depict the P100Q Power Pack but also applies to the P150Q Power Pack.

Check hydraulic tank oil level gauge (A).

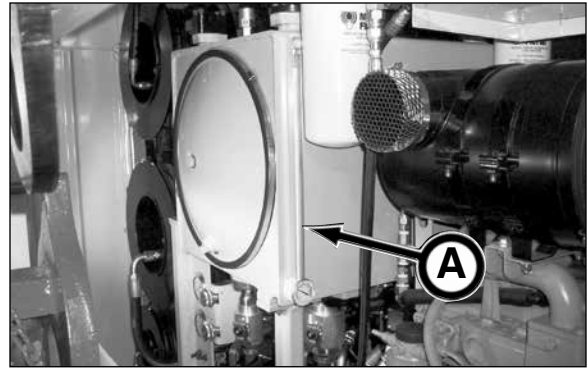

If the fluid level in the reservoir is less than 3/4 full, fill the reservoir with ISO-VG-46 20W Premium Hydraulic Turbine Oil as follows:

1. Remove hydraulic fill hose from storage location. Remove cap from hose.



2. Place hose into hydraulic oil container.

NOTICE Refer to Fuels & Lubricants section for recommended hydraulic oil.



3. Open hydraulic fill shut off valve by moving handle up to the 12 o'clock position.



4. Turn Oil Pump switch ON.



(continued on next page)

5. Fill until oil reaches the high mark on gauge (A).

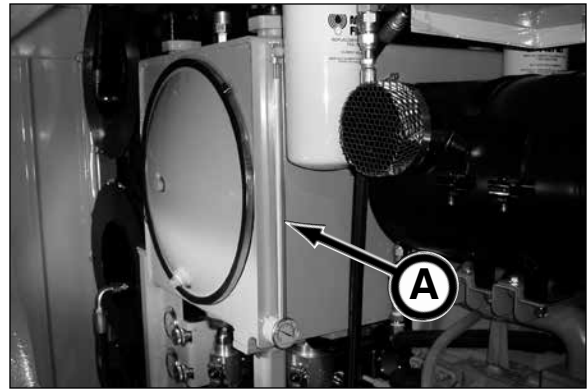

6. Turn Oil Pump switch OFF.



7. Close hydraulic fill shut off valve by moving the handle down to the 3 o'clock position.



8. Replace cap on fill hose and place hose in storage location.



20. CHECK ENGINE COOLANT LEVEL

⚠WARNING Cooling system under pressure. Explosive release of HOT engine coolant can cause severe burns. SLOWLY remove the radiator cap ONLY if the engine is cool. DO NOT remove the radiator cap when the engine is hot.

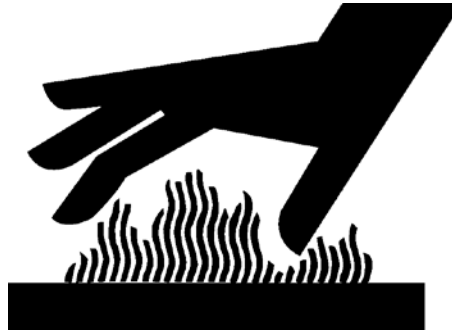

Check coolant level when engine is cold. Coolant level should be at bottom of filler neck (P275T and P150Q) or to the Cool indicator on the coolant tank (P275T only). If coolant level is low, fill radiator with proper coolant solution.

See Engine Coolant in the Fuels & Lubricants section for proper coolant specification. The following coolant capacities are approximate values. Be sure to check levels after filling. DO NOT OVERFILL.

Coolant Capacity:

P150Q: 9 qt (8.5 L)

P275T: 40 qt (38 L)



P275T

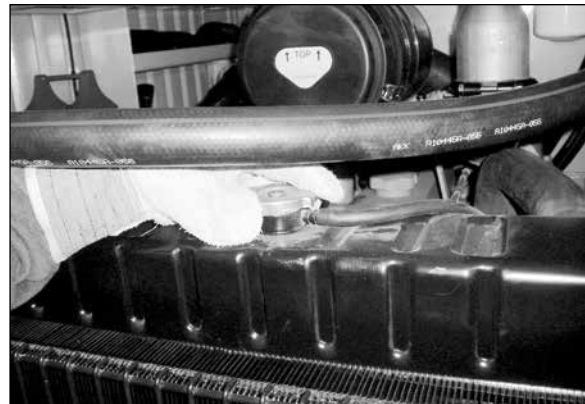

P150Q

21. DRAIN FUEL/WATER SEPARATOR - P275T

Check the primary fuel filter (A) and the final fuel filter (B) for water or debris.

1. Loosen drain plug (C) at bottom of fuel filters, half to one turn.
2. Loosen air bleed plugs (D) two full turns on fuel filter mounting and drain water from bottom until fuel starts to drain out.
3. When fuel starts to drain out, tighten drain plugs securely.

After draining water from the fuel filters, the filter must be primed by bleeding all air from the fuel system.

4. Loosen the air bleed plug on fuel filter base two full turns by hand.
5. Operate primer lever (E) of the fuel supply pump until fuel flows out of bleed plug.
6. Tighten bleed plug securely, continue operating hand primer until pumping action is not felt. Push hand primer inward (toward engine) as far as it will go.

If the fuel system needs further bleeding of air, see Bleeding Fuel System in your engine manual.

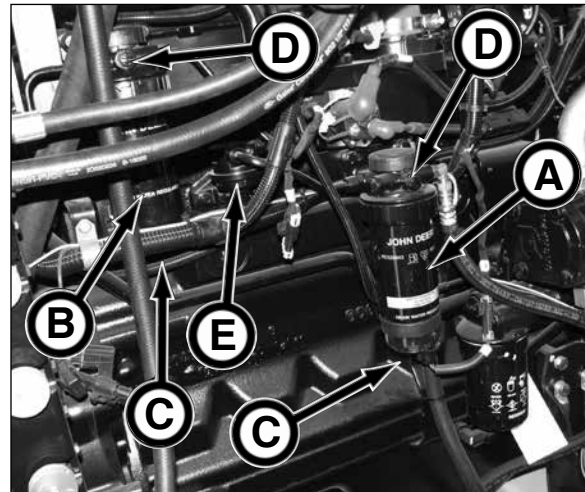

A - Primary Fuel Filter
B - Final Fuel Filter
C - Drain Plug
D - Air Bleed Plugs
E - Primer Lever

21. DRAIN FUEL/WATER SEPARATOR - P150Q

1. Loosen drain plugs (F) at bottom of fuel filters, half turn to one turn.
2. Loosen air bleed plugs (G) two full turns on fuel filter base and drain water from bottom until fuel starts to drain out.
3. When fuel starts to drain out, tighten drain plugs securely.

After draining water from the fuel filter, the filter must be primed by bleeding all air from the fuel system.

4. Operate primer lever (H) of the fuel supply pump until fuel flow is free from air bubbles.
5. Tighten bleed plug securely, continue operating hand primer until pumping action is not felt. Push hand primer inward (toward engine) as far as it will go.

6. Start engine and check for leaks.

If the fuel system needs further bleeding of air, see Bleeding Fuel System in your engine manual.

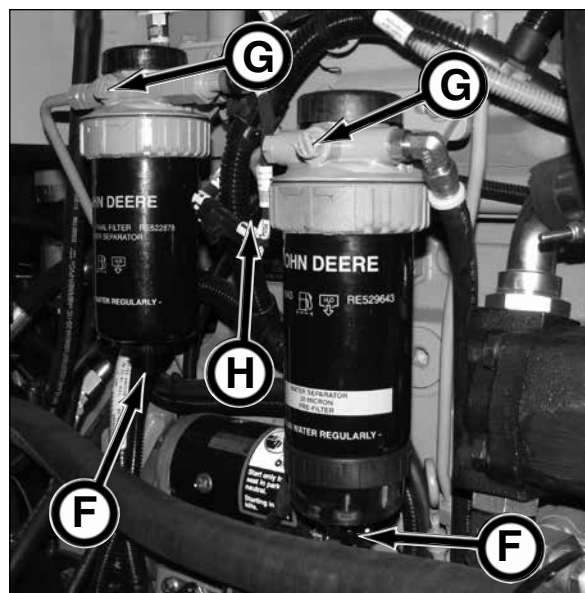

F - Drain Plug
G - Air Bleed Plugs
H - Primer Lever

22. INSPECT FAN & FAN GUARD

⚠ WARNING NEVER operate engine without fan guard in place. Serious personal injury could result if contact is made with rotating fan.

With engine shut off and key removed from control pendant to prevent accidental starting, check fan for cracks, and bent or loose blades. Check fan to make sure it is properly mounted. Replace damaged fan and fan guard.

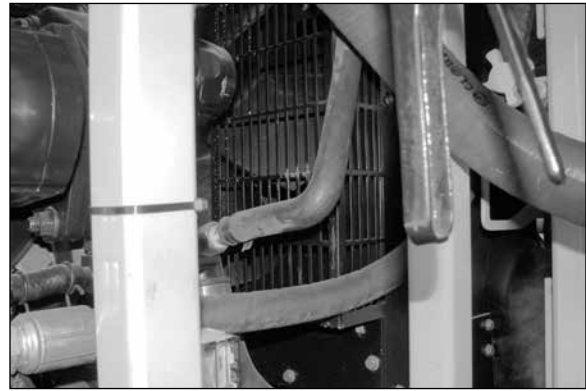

P275T Shown

23. INSPECT BELT

Visually inspect the drive belt (A) for cracking, fraying or pieces of material missing. Replace belts as needed. See your Engine Operator's Manual for belt replacement.

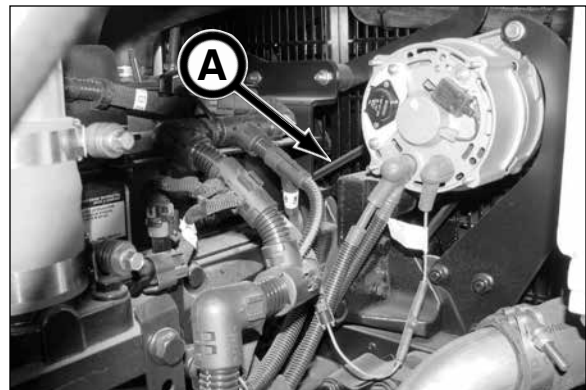

P275T Shown

24. CHECK BREAKOUT TOOL POWER UNIT OIL LEVEL

NOTICE Be sure cylinder (B) is fully retracted before checking oil level.

1. Clean area around filler cap (C).
2. Retract cylinder (B).
3. Tip the end of the power unit with the filler cap up. Remove filler cap and check that oil is filled to the top of filler collar.
4. If needed, fill reservoir with ISO-VG-46 20W Premium Hydraulic/Turbine Oil or equivalent. Replace filler cap.
5. Bleed air from system as follows: Position cylinder on its side with the fittings up, place the power unit flat on ground, cycle the cylinder several times (fully extend and retract), tip the power unit with the filler cap up, and open filler cap to recheck oil level in reservoir. Add additional oil as needed.
6. Replace filler cap. Tighten cap a half to one full turn after o-ring contacts sealing surface.

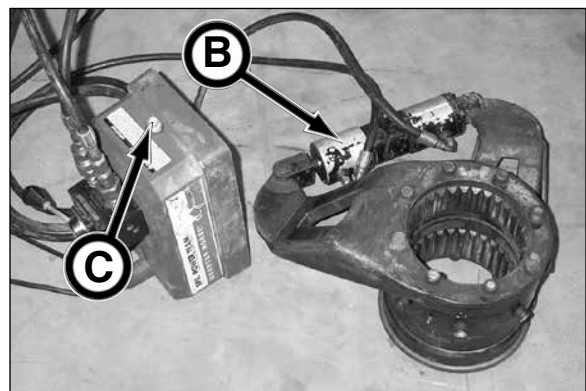

25. LUBRICATE BREAKOUT TOOL

Lubricate breakout tool (A) with 2 shots of Mobilgrease® XHP222 or equivalent at each grease fitting (4 places).

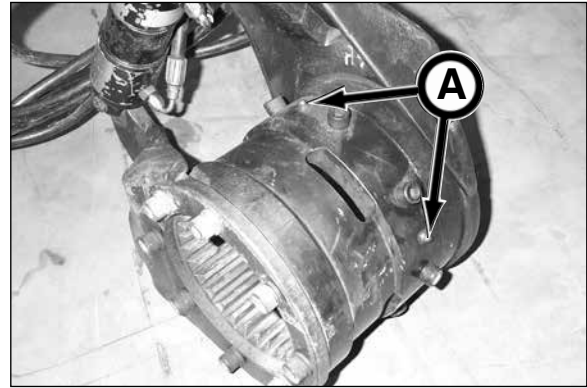

26. LUBRICATE DRIVE ADAPTER/SWIVEL

Lubricate drive adapter/swivel (B) (2 places) with 3 to 5 shots of Mobilgrease® XHP222 or equivalent.

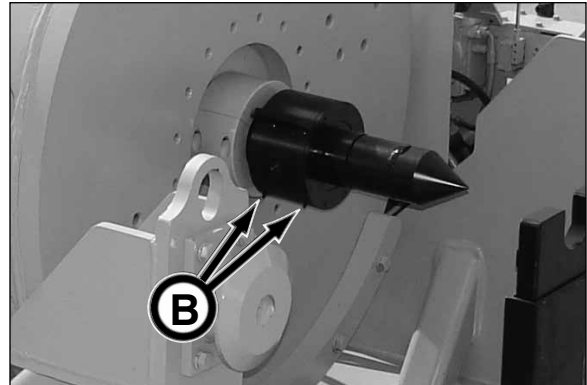

27. LUBRICATE DIRT BUCKET LIFTING EYE

Lubricate lifting eyes (C) (2 places) with Mobilgrease® XHP222 or equivalent until grease is forced out.

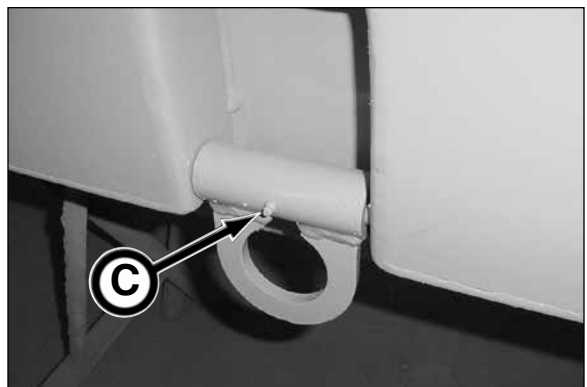

FIRST 100 HOURS OF OPERATION & EVERY 500 HOURS THEREAFTER

28. CHANGE ENGINE OIL & FILTER

NOTICE

This engine is filled with SAE 10W30 break-in oil. Drain oil and replace filters after the first 100 hours maximum operation. Use seasonal viscosity oil as specified in Fuels & Lubricants section for makeup during break-in and replacement.

1. Gain access to the engine oil drain hose.



P275T



P150Q

2. Remove cap from hose.
3. Drain oil into a catch pan of proper size.
4. Reinstall cap to hose.



P275T

(continued on next page)



P150Q

5. Replace drain hose with tie strap.



P275T

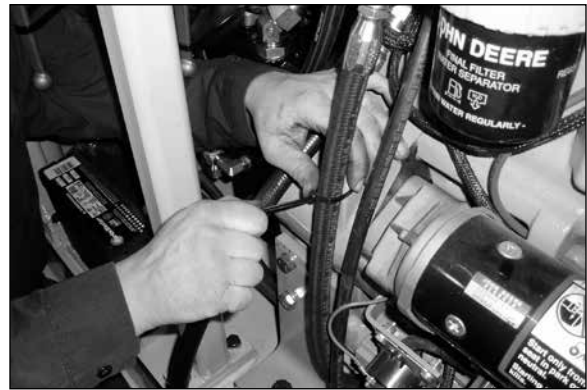

P150Q

6. Clean and dry area around the oil filter (A).

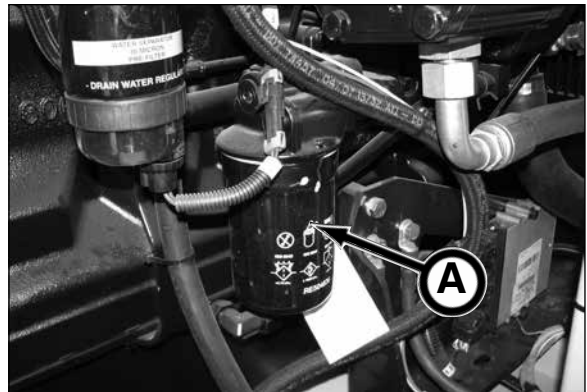

P275T



P150Q

(continued on next page)

7. Remove oil filter and clean filter mounting pad.
Dispose of filter properly.



P275T Shown

8. Lubricate gasket on new filter with clean oil.
9. Fill filter with new, clean engine oil.
10. Install new filter and hand tighten according to values printed on the filter. Do not overtighten the filter element.



P275T Shown

11. Remove fill cap.
12. Fill engine with engine oil specified in the Fuels & Lubricants section. The following fluid capacities are approximate values. Be sure to check levels after filling. DO NOT OVERFILL.

Oil Capacity

P150Q	21.6 qt (20.5 L)
P275T	28.5 qt (27 L)

NOTICE

DO NOT fill above the top mark on the dipstick. Oil levels anywhere within crosshatch marks are considered in the acceptable operating range.

13. Install fill cap. Hold and screw cap handle clockwise to tighten. Clean up spills.
14. Start engine and run until warm and check for leaks.
15. Shutdown engine. Wait approximately 5 minutes to let the oil drain from the upper portion of the engine. Check oil level. Oil level should be on upper mark of dipstick.



P275T Shown



P275T

P150Q

MONTHLY OR EVERY 250 HOURS OF OPERATION

29. INSPECT AIR INTAKE & EXHAUST CONNECTIONS - P275T

Inspect all air intake (10 places) and exhaust (4 places) connections. Tighten clamps as needed and replace defective parts.

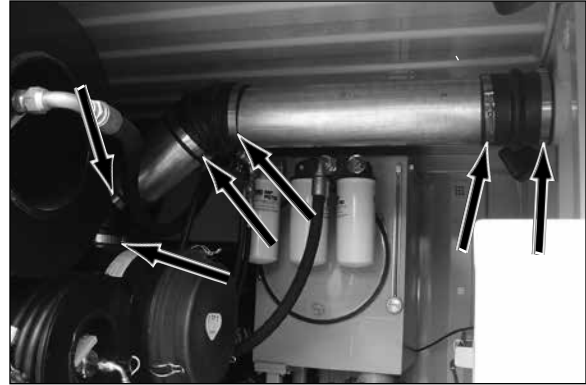

Air Intake System

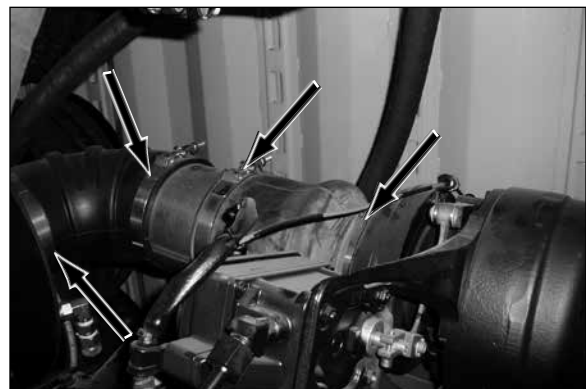

Air Intake System



Exhaust System



Exhaust System

29. INSPECT AIR INTAKE & EXHAUST CONNECTIONS - P150Q

Inspect all air intake (2 places) and exhaust (4 places) connections. Tighten clamps as needed and replace defective parts.



Air Intake System

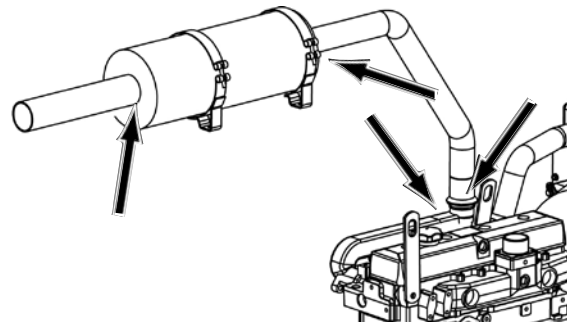

Exhaust System

30. CHECK BATTERY

⚠ WARNING Batteries produce explosive gases. Wear eye protection and protective clothing during battery service. Keep sparks, flames, and cigarettes away from batteries.

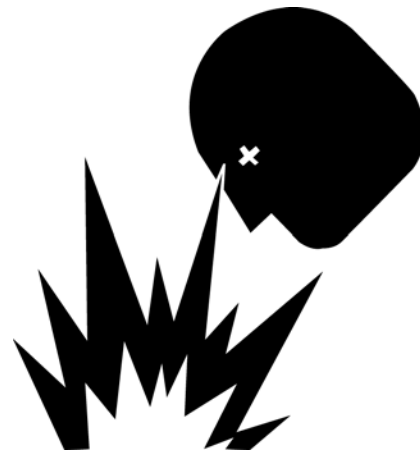

Visually check the battery for damage. If damaged replace with new.

Check battery cables for damage or fraying. If damaged, replace with new.

Be sure cables are secured properly to the battery posts and engine mounts.

Inspect battery mount and strap for damage.



P275T Shown

31. INSPECT ENGINE MOUNTS

Visually inspect engine mounts for loose hardware or damaged parts.

Tighten all loose hardware and replace defective parts.

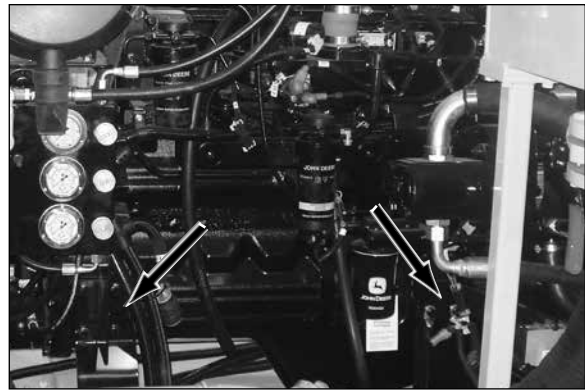

P275T



P150Q

32. INSPECT & CLEAN FUEL TANK CAP

Inspect cap for damage. If cap is damaged, replace with new.

Remove cap and clean any debris or dirt from cap body.



P275T Shown

33. CHECK AUGER DRIVE OIL LEVEL

Check gear box oil level by removing check plug (A).

If oil does not flow out of check plug hole, add Mobil SHC 630 Synthetic Bearing & Gear Oil into gear box oil fill port (B) until oil flows out of check plug hole. Reinstall check plug.

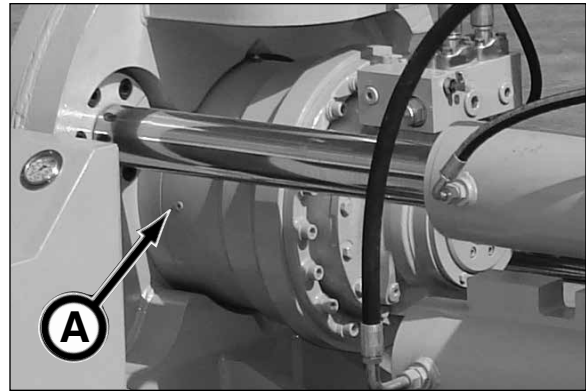

Auger Drive Check Port SN 1-3

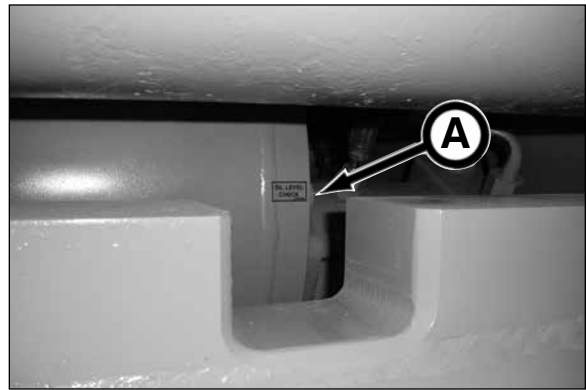

Auger Drive Check Port SN 4 & After

4812A SN 1 - 3 ONLY:

Breather (B) should be removed if shaft may be flooded when not in use. Replace breather with plug.

BEFORE operating machine, replace breather otherwise drive damage will occur.

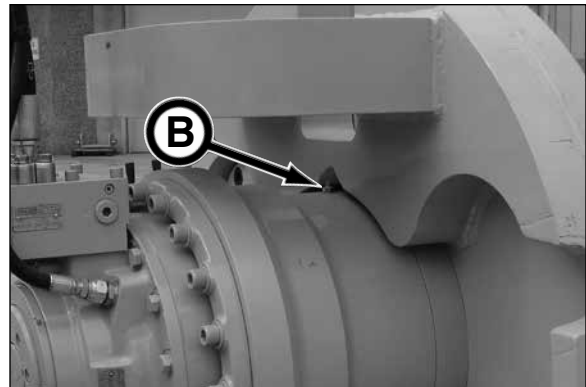

Auger Drive Fill Port SN 1-3

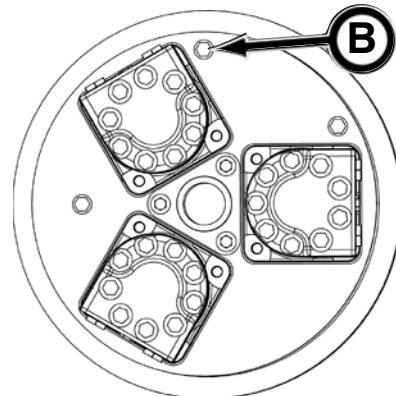

Auger Drive Fill Port SN 4 & After

34. REPLACE BREAKOUT TOOL POWER UNIT OIL

1. Clean area around filler cap (A).
2. Retract cylinder (B).
3. Open filler cap and drain oil from reservoir.
4. Flush reservoir.
5. Refill the reservoir by tipping the end of the power unit with the filler cap up (vertical position). Remove filler cap and fill oil to the top of filler collar with ISO-VG-46 20W Premium Hydraulic/ Turbine Oil or equivalent. Replace filler cap.
6. Bleed air from system as follows:
 - a. Position cylinder on its side with the fittings facing up.
 - b. With the power unit flat on ground (horizontal position), cycle the cylinder several times (fully extend and retract).
 - c. Tip the power unit with the filler cap up, and open filler cap to recheck oil level in reservoir. Add additional oil as needed.
7. Replace filler cap. Tighten cap a half to one full turn after o-ring contacts sealing surface.

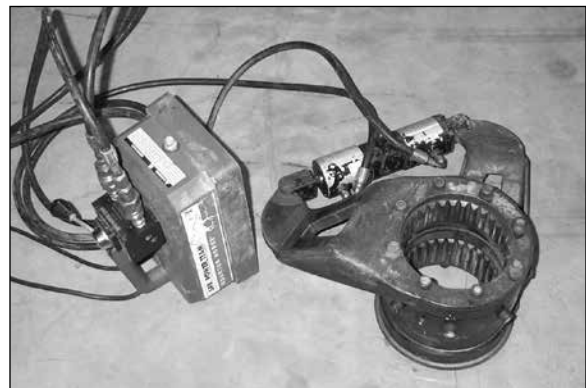
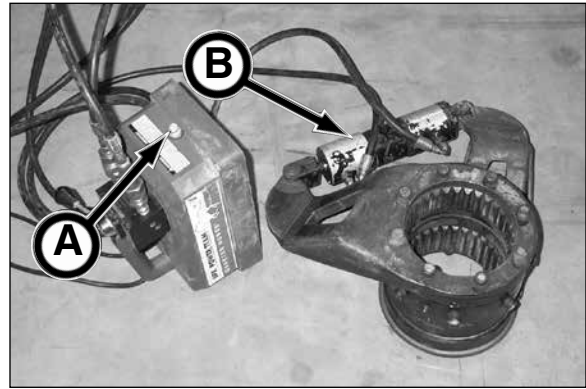

35. CHARGE TABLET PC BATTERY

Charge Tablet PC battery to keep the battery charged properly. Failure to fully charge battery will result in shortened battery life and cause GBM_System program to load incorrectly at start up.

Be sure to store computer between 50°F and 86°F (10°C and 30°C).

Unused or stored batteries can lose power over time. When using a computer with a battery that has not been used for awhile, connect external power to the computer and fully charge battery before booting up computer.

For more battery performance information, on the task bar located at the bottom of the tablet screen, click the start button and then click Battery Tips.

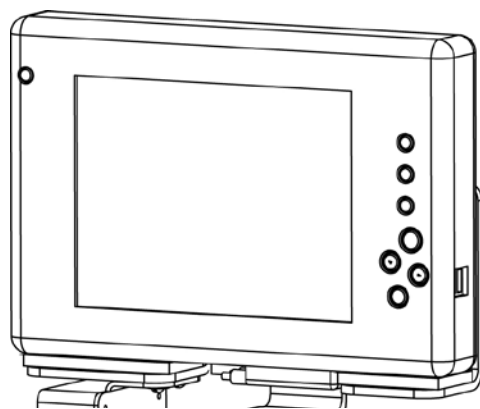

EVERY 500 HOURS OF OPERATION

36. CHANGE ENGINE OIL & FILTER

NOTICE This engine is filled with SAE 10W30 break-in oil. Drain oil and replace filters after the first 100 hours maximum operation. Use seasonal viscosity oil as specified in Fuels & Lubricants section for makeup during break-in and replacement.

1. Gain access to the engine oil drain hose.



P275T



P150Q

2. Remove cap from hose.
3. Drain oil into a catch pan of proper size.
4. Reinstall cap to hose.



P275T

(continued on next page)



P150Q

5. Replace drain hose with tie strap.



P275T



P150Q

6. Clean and dry area around the oil filter (A).

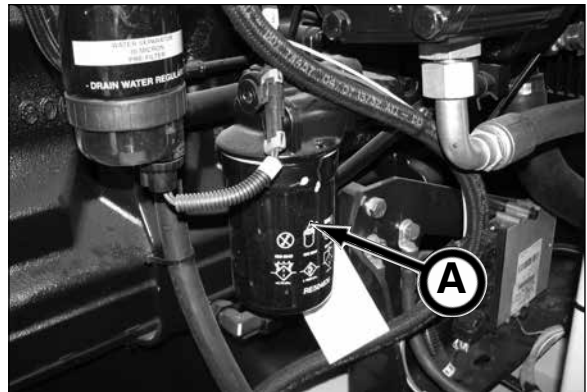

P275T



P150Q

(continued on next page)

7. Remove oil filter and clean filter mounting pad.
Dispose of filter properly.



P275T Shown

8. Lubricate gasket on new filter with clean oil.
9. Fill filter with new, clean engine oil.
10. Install new filter and hand tighten according to values printed on the filter. Do not overtighten the filter element.



P275T Shown

11. Remove fill cap.
12. Fill engine with engine oil specified in the Fuels & Lubricants section. The following fluid capacities are approximate values. Be sure to check levels after filling. DO NOT OVERFILL.

Oil Capacity

P150Q	21.6 qt (20.5 L)
P275T	28.5 qt (27 L)

NOTICE

DO NOT fill above the top mark on the dipstick. Oil levels anywhere within crosshatch marks are considered in the acceptable operating range.

13. Install fill cap. Hold and screw cap handle clockwise to tighten. Clean up spills.
14. Start engine and run until warm and check for leaks.
15. Shutdown engine. Wait approximately 5 minutes to let the oil drain from the upper portion of the engine. Check oil level. Oil level should be on upper mark of dipstick.



P275T Shown



P275T

P150Q

37. REPLACE AIR CLEANER FILTERS

NOTICE The photos in this procedure depict the P275T Power Pack but also applies to the P150Q Power Pack.

Replace air cleaner elements at 500 hours or 12 months, whichever occurs first.

1. Clean area around the air cleaner assembly.

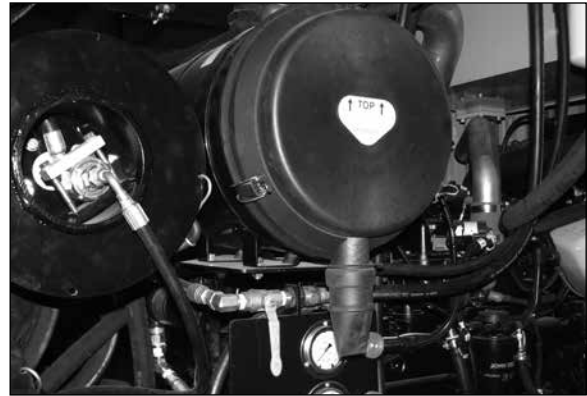

2. Unlatch and remove cover.

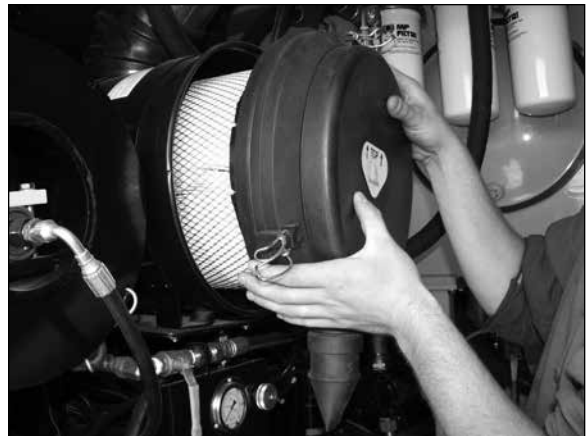

3. Gently remove primary element. Bumping the element against air cleaner housing may contaminate the clean side of the filter housing with dirt and dust.

4. Properly dispose of primary element.

5. Thoroughly clean out the inside of filter housing with a clean, damp cloth. Dirt left in the filter housing will shorten the life of the filter elements.



(continued on next page)

6. Gently remove secondary (safety) element.
Immediately install a new secondary element to prevent any dirt or dust from entering the air intake system.

NOTICE NEVER run the engine without the secondary element in place. Doing so will cause engine damage.

Replacement of the secondary element is usually necessary only when the primary element has a hole in it.

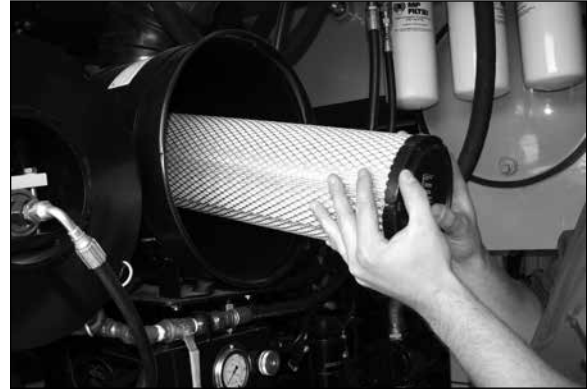

7. Carefully install a new primary filter element by applying pressure by hand at outer rim of filter.

NOTICE Do not use latches on cover to force filter into air cleaner. Using cover to force filter into housing will damage cleaner housing.



8. Replace cover with dust unloader valve facing down (6 o'clock position). Secure the latches.



38. REPLACE FUEL FILTERS - P150Q

1. Clean area around fuel filter assemblies.
2. Loosen drain plugs (A) and drain fuel into a proper container.
3. Hold the retaining ring (B) and rotate it counterclockwise 1/4 turn. Remove ring with filter element (C).

Lifting up on retaining ring as it is rotated helps to get it past the raised locators on the fuel filter.

On the filter with the water separator bowl (D), remove filter element from separator bowl. Drain and clean separator bowl. Dry with compressed air. Install bowl onto new element. Tighten securely.

4. Inspect filter mounting base (E) for damage. Clean as needed.
 5. Install new filter elements onto mounting base. Be sure element is properly indexed and firmly seated on base. The filter may need to be rotated for correct alignment.
- Raised locators on fuel filter must be indexed properly with slots in mounting base for correct installation.
6. Align keys on filter element with slots in filter base.
 7. Install retaining ring onto mounting base making sure the dust seal is in place on filter base. Hand tighten ring, about 1/3 turn, until it "snaps" into the detent. Do not overtighten retaining ring.

The proper installation is indicated when a "click" is heard and a release of the retaining ring is felt.

A plug is provided with the new element for plugging the used element.

8. Bleed the fuel system (refer to 39. Bleeding The Fuel System in this section).

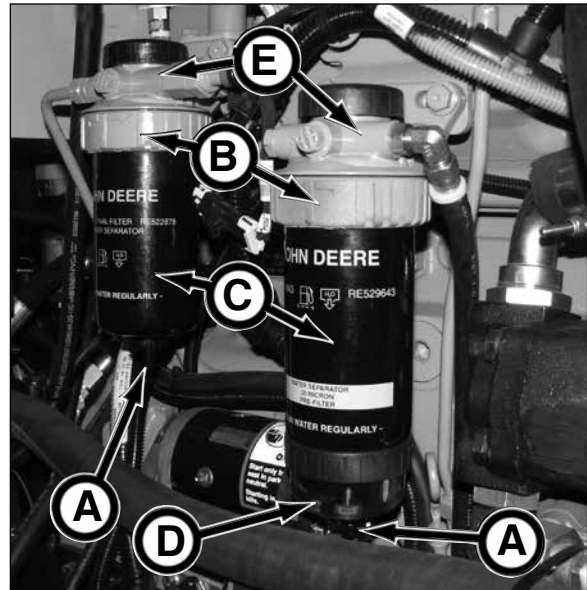

A - Drain Plugs
B - Retaining Rings
C - Filter Element
D - Water Separator Bowl
E - Filter Mounting Base

39. BLEEDING THE FUEL SYSTEM

NOTICE The photos in this procedure depict the P275T Power Pack but also applies to the P150Q Power Pack.

Whenever the fuel system has been opened up for service (lines disconnected or filters removed), it will be necessary to bleed air from the fuel system.

1. Loosen bleed screw (A) two full turns by hand on fuel filter base.

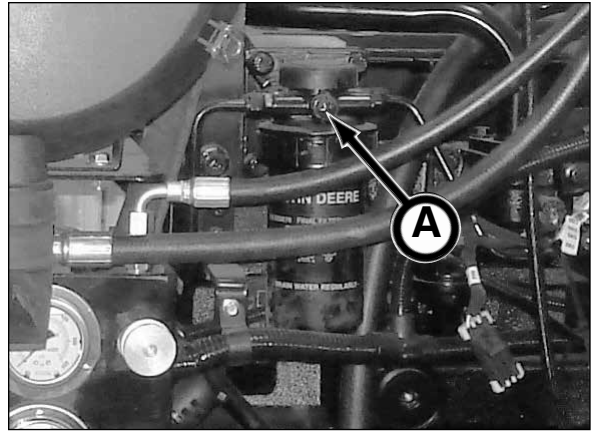

P275T Shown

2. Operate pump primer lever (B) until fuel flows out of bleed vent screw.

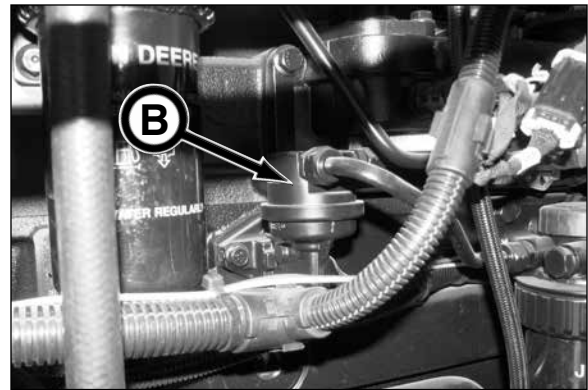

P275T Shown

3. Tighten bleed plug securely, and continue operating hand primer until pumping action is not felt. Push hand primer inward (toward engine) as far as it will go.

4. Start engine and check for leaks.

If engine will not start, repeat steps 1 - 4.

NOTICE If engine will not start, it may be necessary to bleed air from fuel system at fuel injection pump or injection nozzles. Refer to your John Deere engine manual for service information.

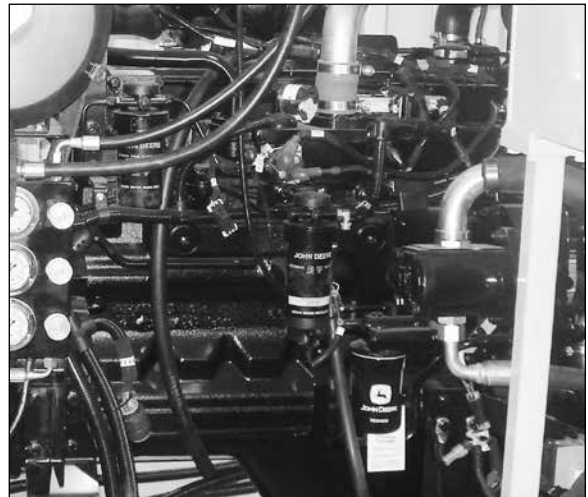

P275T Shown

40. CLEAN CRANKCASE VENT TUBE

1. Remove and clean crankcase tube (C).

2. After cleaning, install tube and tighten hose clamps securely.

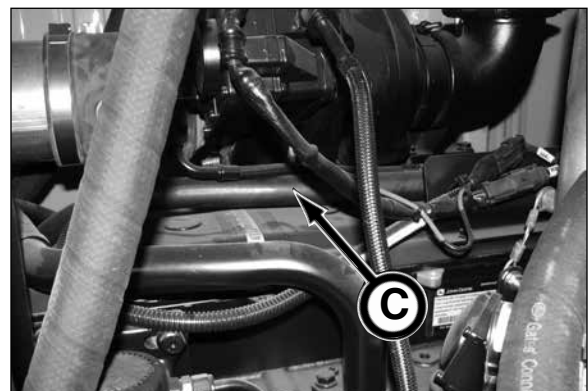

P275T Shown

41. CHECK COOLING SYSTEM

⚠ WARNING Cooling system under pressure. Explosive release of HOT engine coolant can cause severe burns. SLOWLY remove the radiator cap ONLY if the engine is cool.

1. Visually check the cooling system for leaks. Tighten all clamps securely.
2. Check to be sure the coolant level is at the bottom of the filler neck. Add coolant mixture if needed. Refer to Engine Coolant in the Fuels & Lubricants section of this manual.
3. Inspect all cooling system hoses. If the hoses are found to be in a hard, weak, or cracked condition, replace the hose(s).
4. Check the radiator for bent fins. Carefully straighten fins.
5. Check the inlet and outlet tubes for cracks, kinks, dents, or fractured seams. Repairs must be made by a qualified radiator technician.
6. Check the effectiveness of the coolant solution. Refer to your Deere engine manual for service information.
7. Pressure test the cooling system. Refer to your Deere engine manual for service information.

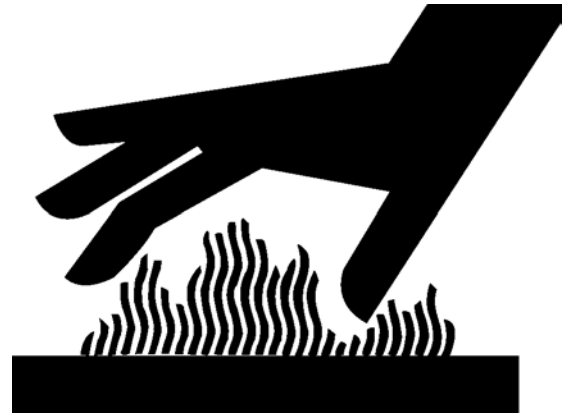

P275T Shown



P275T Shown

42. CHECK BELT & BELT TENSIONER

1. Inspect the drive belt (A) for excessive wear or damage. If damaged, replace with new.
2. Check the drive belt tensioner for proper operation. If tensioner is not working properly, refer to your Deere engine manual for service information.

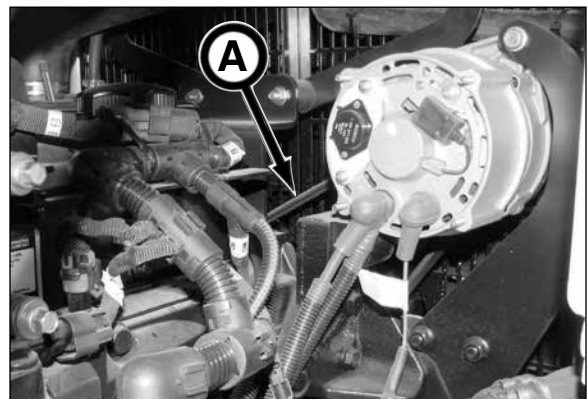

P275T Shown

43. REPLACE LOAD SENSE FILTERS - P275T

The rotation pump load sense filter (A), PCH cutter drive pump load sense (B), and jacking thrust pump load sense filter (C) must be replaced at:

- 500 hours or yearly, which ever occurs first
- a major component fails
- any signs of water contamination
- hydraulic fluid sample indicates large particle contamination
- controls are sluggish

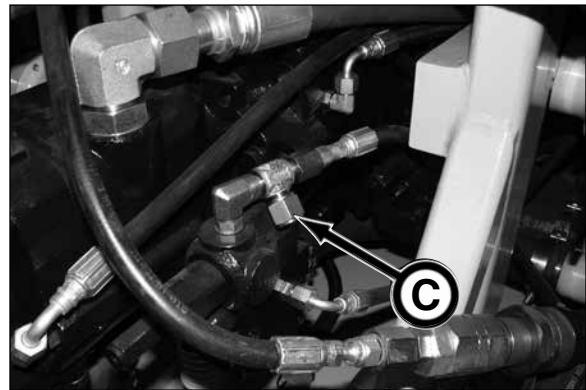
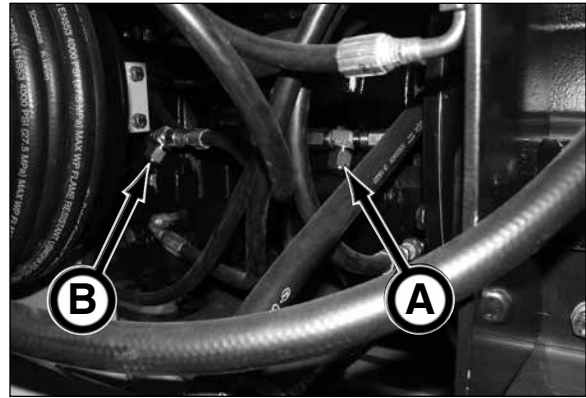

NOTICE Installing a load sense filter incorrectly, WILL cause pump malfunction.

1. Remove cap, spring, and filter from filter head.
2. Insert new filter (D) with nylon ring end (E) into filter head (F).
3. Place spring (G) into cap (H).
4. Install cap onto filter head. Tighten to 10 ft-lb (13.6 N·m) torque.

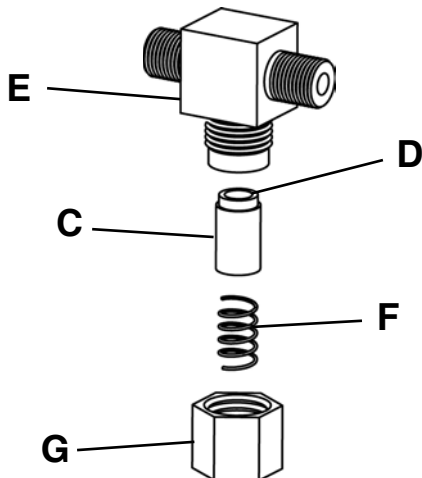
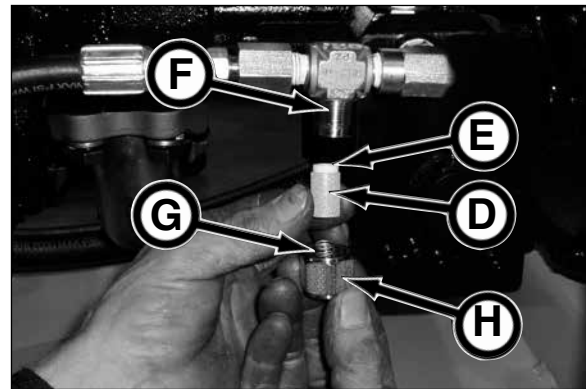

Load Sense Filter Installation

43. REPLACE LOAD SENSE FILTERS - P150Q

The load sense filters must be replaced at:

- 500 hours or yearly, which ever occurs first
- a major component fails
- any signs of water contamination
- hydraulic fluid sample indicates large particle contamination
- controls are sluggish

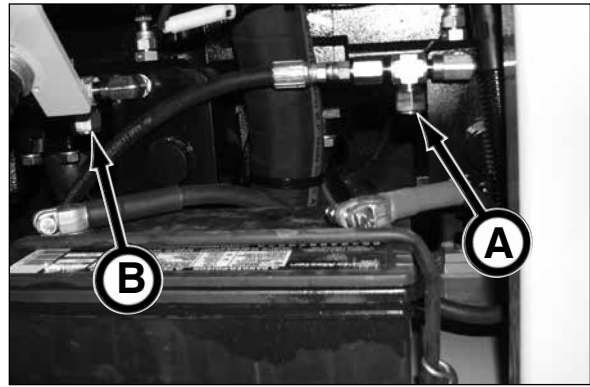

Powered Cutter Drive Load Sense Filter (A)
Thrust (Jacking) Pump Load Sense Filter (B)
Rotation/Auger Drive Pump Load Sense Filter (C)



NOTICE Installing a load sense filter incorrectly, WILL cause pump malfunction.

1. Remove cap, spring, and filter from filter head.
2. Insert new filter (D) with nylon ring end (E) into filter head (F).
3. Place spring (G) into cap (H).
4. Install cap onto filter head. Tighten to 10 ft-lb (13.6 N·m) torque.

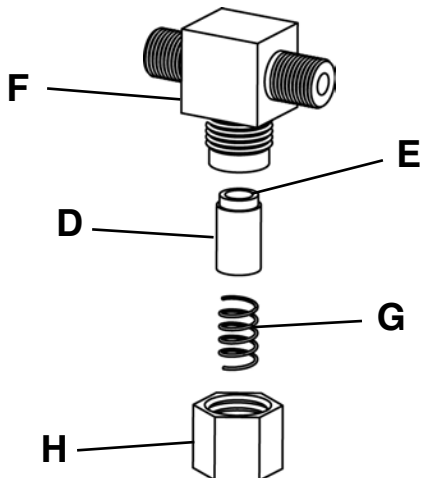
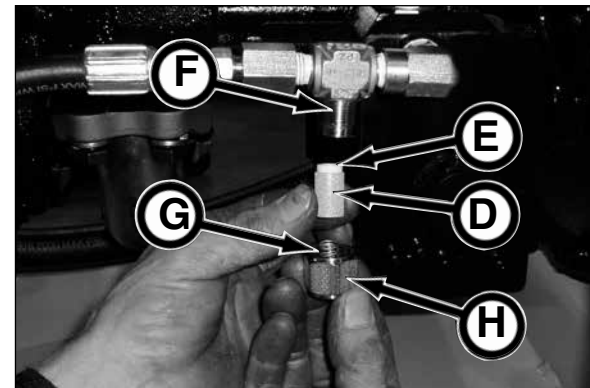

Load Sense Filter Installation



EVERY 1000 HOURS OF OPERATION

44. DRAIN & FILL HYDRAULIC RESERVOIR - P275T

1. Remove hydraulic tank drain plug (A) and drain oil into a 80 gal (302.8 L) catch pan.
2. Replace tank drain plug.

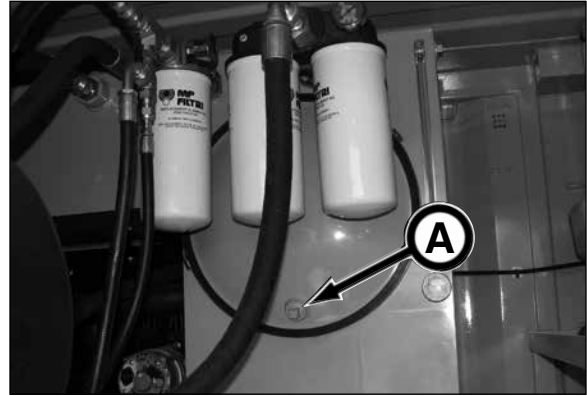

3. Remove hydraulic fill hose from storage location. Remove cap from hose.



4. Place hose into hydraulic oil container.

NOTICE Refer to Fuels & Lubricants section for recommended hydraulic oil.



5. Open hydraulic fill ball valve by moving handle up to the 3 o'clock position.



(continued on next page)

NOTICE

Remove tank breather to vent tank during filling. Be sure to replace breather after filling.

6. Turn Oil Pump switch ON.

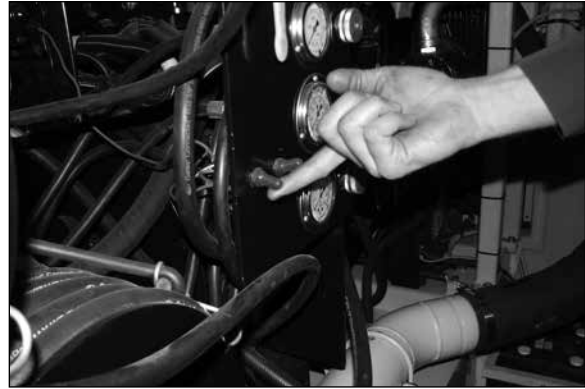

7. Fill until oil reaches the high mark on gauge (A).



8. Turn Oil Pump switch OFF.



9. Close hydraulic fill ball valve by moving the handle down to the 6 o'clock position.



10. Replace cap on fill hose and place hose in storage location.



44. DRAIN & FILL HYDRAULIC RESERVOIR - P150Q

1. Remove hydraulic tank drain plug (A) and drain oil into a 40 gal (151 L) catch pan.
2. Replace tank drain plug.

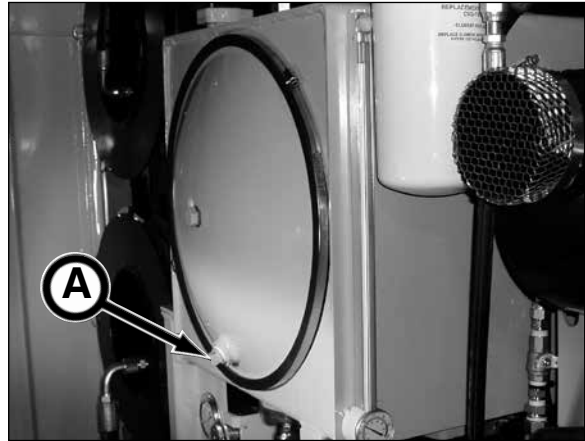

3. Remove hydraulic fill hose from storage location. Remove cap from hose.



4. Place hose into hydraulic oil container.

NOTICE Refer to Fuels & Lubricants section for recommended hydraulic oil.



5. Open hydraulic fill shut off valve by moving handle up to the 12 o'clock position.

(continued on next page)



6. Turn Oil Pump switch ON.

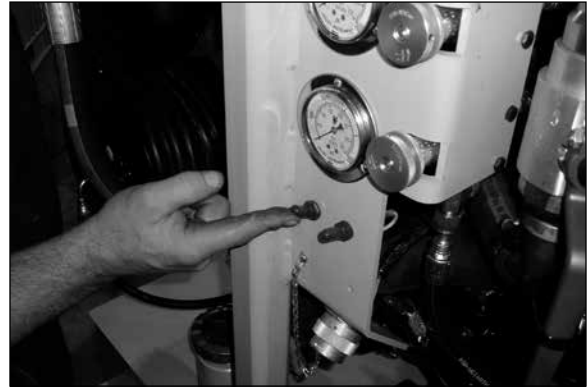

7. Fill until oil reaches the high mark on gauge (A).

Fluid Capacities:

P150Q: 50 gal (189 L)

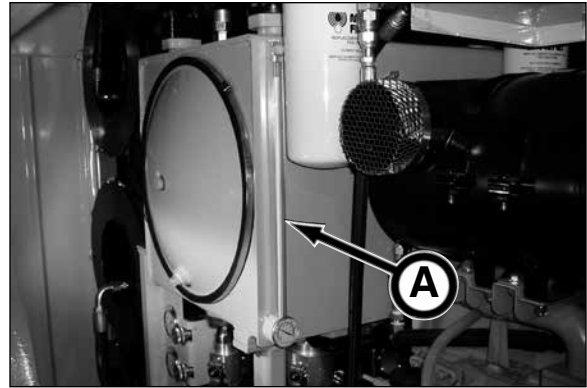

8. Turn Oil Pump switch OFF.

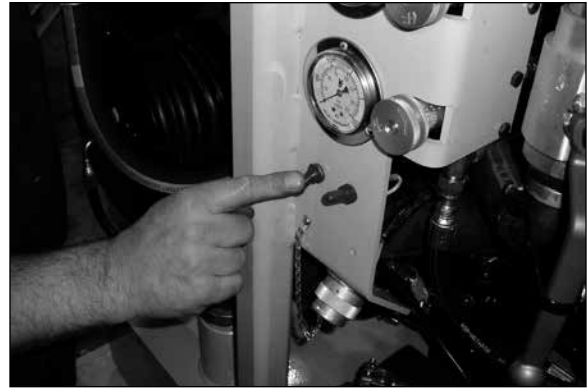

9. Close hydraulic fill shut off valve by moving the handle down to the 3 o'clock position.



10. Replace cap on fill hose and place hose in storage location.



45. DRAIN & FILL AUGER DRIVE OIL

1. Clean and dry area around the auger drive drain plug.
2. Remove drain plug (A).
3. Drain auger drive oil into a proper sized catch pan. Dispose of oil properly.
4. Replace drain plug.

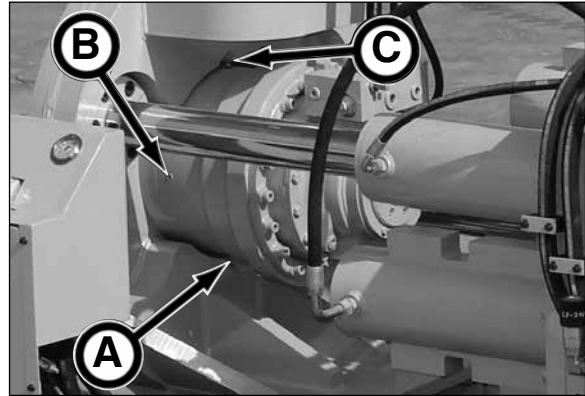

Auger Drive SN 1 - 3

5. Remove check plug (B).
6. Clean and dry area around the fill plug (C).
7. Remove fill plug.
8. Fill auger drive with Mobil SHC 630 Synthetic Bearing and Gear Oil or equivalent until oil flows out of check plug hole. Do not mix oil manufacturers or grades.
9. Replace fill plug and gear box cover.

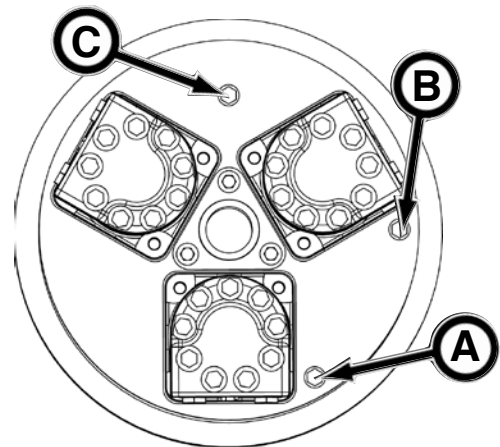

Auger Drive SN 4 & After

46. RECALIBRATE THEODOLITE

The theodolite is a sensitive optical instrument that requires special care and maintenance to maintain its accuracy.

Ship your theodolite to an authorized Nikon service center for recalibration every 1000 hours of operation. This will maintain the line and grade of the theodolite optics.

If the theodolite is bumped, dropped or if the accuracy is questioned, the theodolite must be recalibrated. Keep in mind if the theodolite is misaligned one degree, you will be off nearly two ft (0.6 m) per 100 ft (30.5 m) in the drive.



EVERY 2000 HOURS OF OPERATION

47. FLUSH & FILL COOLING SYSTEM - P275T

NOTICE The photos in this procedure depict the P275T Power Pack but also applies to the P150Q Power Pack.

WARNING Cooling system under pressure. Explosive release of HOT engine coolant can cause severe burns. SLOWLY remove the radiator cap ONLY if the engine is cool enough to touch with bare hands.

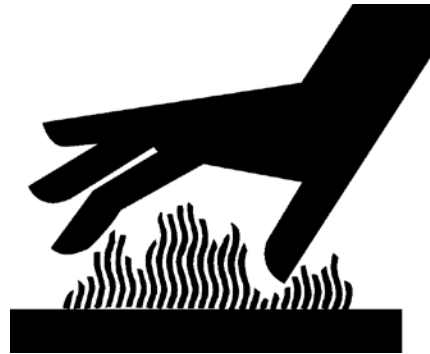

1. With gloves and eye protection, slowly remove the radiator cap (A) to relieve pressure and allow coolant to drain faster.
2. Open oil cooler housing coolant drain plug, engine block drain plug, or block heater ports. Drain all coolant from engine block into catch pan. Dispose of coolant properly.
3. Open radiator drain valve (B). Drain all coolant from radiator into catch pan. Dispose of coolant properly.
4. Remove thermostats (refer to your engine manual for service information) and install cover (without thermostats and seals) and tighten cap screws to 49-59 ft.lb. (66-80 N·m) for P275T and 35 ft.lb. (47 N·m) for P150Q.
5. Test thermostat opening temperature (refer to your John Deere engine manual).
6. After coolant has drained, close drain valves.

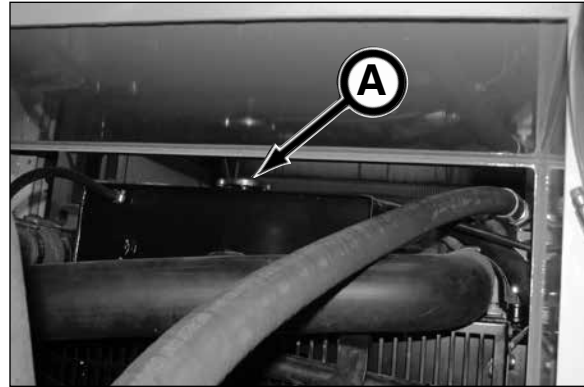

NOTICE Never add water or coolant to a hot engine. Doing so will result in engine damage.

7. Refill the cooling system with soft, clean water.

CAUTION Do not run engine longer than 10 minutes. Doing so may cause burns when radiator is draining from an overheated engine.

8. Start the engine and run it for about 10 minutes to thoroughly circulate the water and to stir up possible rust or sediment.

(continued on next page)

9. Stop engine and immediately drain the water from the system before rust and sediment settle.

NOTICE

It may be necessary to remove the lower radiator hose (A) to fully drain the system. Be sure to replace radiator hose and tighten clamp after draining.

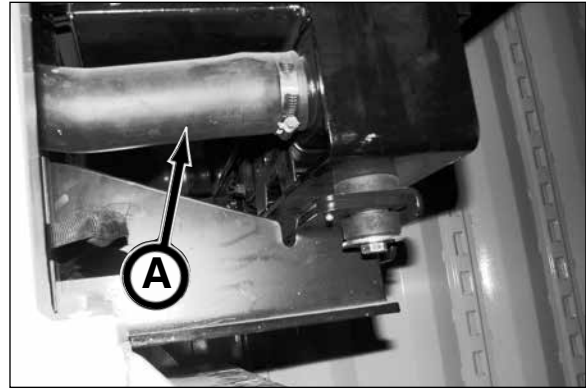

10. After draining water, close all drain valves.
11. Reinstall radiator cap, and if removed, reinstall the lower radiator hose and clamp.
12. Fill the cooling system with clean water and a heavy duty cooling system cleaner. Follow manufacturer's directions on label.
13. After cleaning the cooling system, drain cleaner and fill with water to flush the system.
14. Run the engine about 10 minutes, remove radiator cap and pull off lower radiator hose to drain out flushing water.
15. Close all drain valves on engine and radiator. Reinstall radiator hose and tighten clamps securely. Install thermostats using a new gasket (refer to your John Deere engine manual).

NOTICE

Air must be expelled from cooling system when system is refilled. Loosen plug on top of thermostat housing to allow air to escape when filling system. Retighten plug after filling cooling system. Refer to your John Deere engine manual for details.

NOTICE

DO NOT overfill cooling system. A pressurized system needs space for heat expansion without overflowing at top of radiator.

16. Fill coolant into radiator with a 50% mixture of ethylene glycol engine coolant and distilled, deionized, or demineralized water, and a supplemental coolant additive until the coolant level reaches the bottom of the radiator filler neck or to the cool fill line indicator on the coolant tank.

Approximate coolant capacity:

P275T 40 qt (38 L)



NOTICE

Refer to your John Deere engine manual for information on using a Supplemental Coolant Additive (SCA) in your coolant system.

17. Install radiator cap.

(continued on next page)

18. Start engine and run it until it reaches operating temperature. This will mix the coolant uniformly and circulate it throughout the system. The normal engine coolant temperature range is 180° to 202°F (82° to 94°C).
19. Shut off engine. Check coolant level and add if necessary. Check entire coolant system for leaks.
20. Inspect fan belt for wear and check belt tension. Refer to Check Belt and Belt Tensioner in the Every 500 Hours Of Operation of this section.

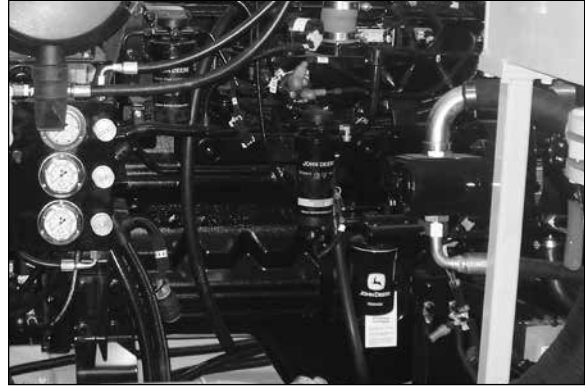

47. FLUSH & FILL COOLING SYSTEM - P150Q

⚠WARNING Cooling system under pressure. Explosive release of HOT engine coolant can cause severe burns. SLOWLY remove the radiator cap ONLY if the engine is cool enough to touch with bare hands.

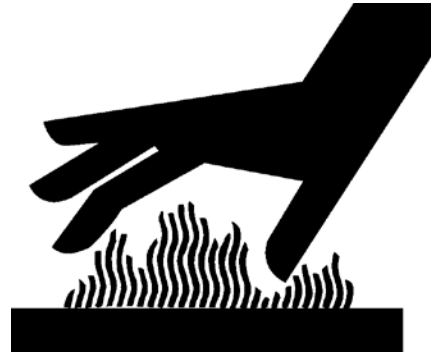

1. With gloves and eye protection, slowly remove the radiator cap (A) to relieve pressure and allow coolant to drain faster.

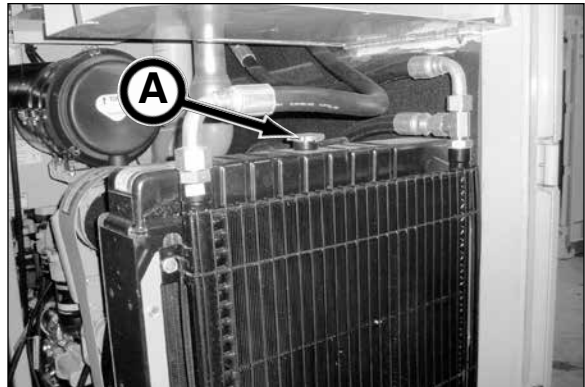

2. Open engine block drain valve (B) on back side of engine. Drain all coolant from engine block into catch pan. Dispose of coolant properly.

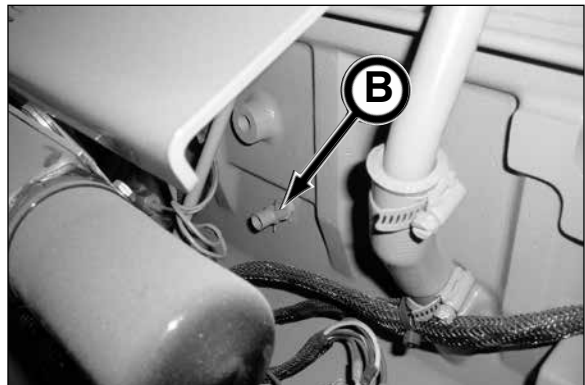

3. Open radiator drain valve (A). Drain all coolant from radiator into catch pan. Dispose of coolant properly.
4. Remove thermostats (refer to your engine manual for service information) and install cover using old gasket and tighten cap screws to 35 ft-lbs (47 N·m).
5. After coolant has drained, close engine block drain valve and radiator drain valve.

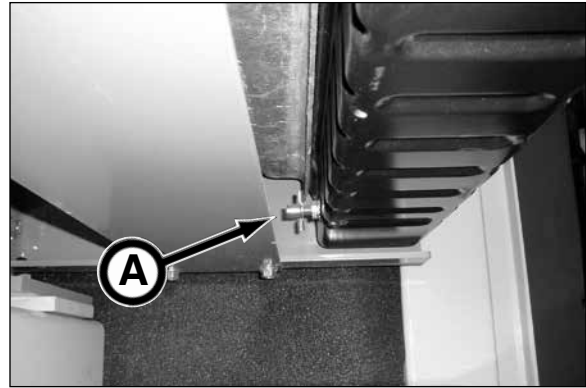

NOTICE Never add water or coolant to a hot engine. Doing so will result in engine damage.

6. Refill the cooling system with soft, clean water.

CAUTION Do not run engine longer than 10 minutes. Doing so may cause burns when radiator is draining from an overheated engine.

7. Start the engine and run it for about 10 minutes to thoroughly circulate the water and to stir up possible rust or sediment.
8. Stop engine and immediately drain the water from the system before rust and sediment settle.

NOTICE It may be necessary to remove the lower radiator hose (B) to fully drain the system. Be sure to replace radiator hose and tighten clamp after draining.



9. After draining water, close the engine and radiator drain valves.
 10. Reinstall radiator cap, and if removed, reinstall the lower radiator hose and clamp.
 11. Continue flushing system until scale deposits, rust, sediment and cooling cleaner (if used) are completely removed.
- NOTICE** Cooling system cleaners may need to be used to remove scale formation. See your engine manual for more information.
12. Close engine drain plug and radiator plug.
 13. (If removed) Reinstall radiator hose and tighten clamp securely.
 14. Install thermostats using a new gasket (see your engine manual for more information).

(continued on next page)

15. Loosen plug (A) in side of thermostat housing (located on back side of engine) to allow air to escape when filling system.

NOTICE DO NOT overfill cooling system. A pressurized system needs space for heat expansion without overflowing at top of radiator.

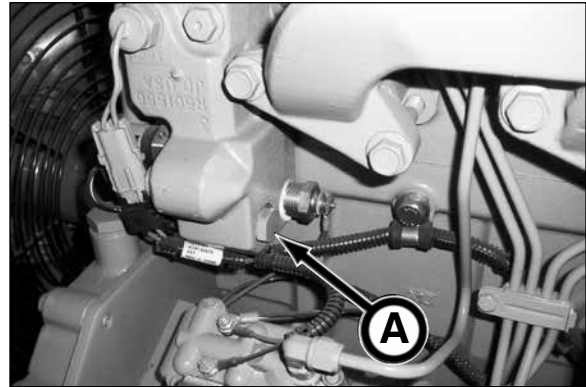

16. Fill coolant into radiator with a 50% mixture of ethylene glycol engine coolant and distilled, deionized, or demineralized water, and a supplemental coolant additive until the coolant level reaches the bottom of the radiator filler neck.
Approximate coolant capacity:
P150Q 9 qt (8.5 L)

NOTICE Refer to your engine manual for information on using a Supplemental Coolant Additive (SCA) in your coolant system.

17. Tighten thermostat housing plug (B) when air has been expelled from system.
18. Replace radiator cap.
19. Start engine and operate it for 5 minutes to circulate the water/coolant/SCA (if used) mixture.
20. Shut off engine.

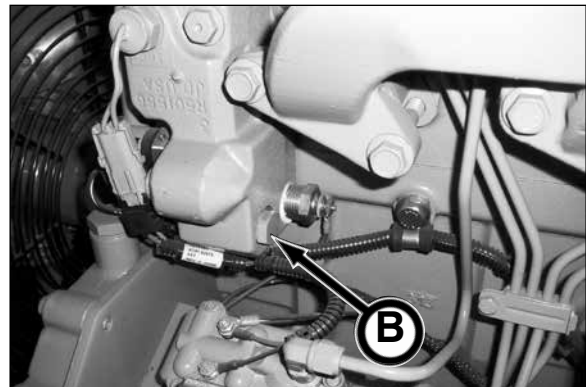

21. SLOWLY remove radiator cap.
22. Check radiator coolant level and fill as needed for coolant to reach the bottom of the filler neck.
23. Replace radiator cap (C).
24. Start engine and run it until it reaches operating temperature. This will mix the coolant uniformly and circulate it throughout the system. The normal engine coolant temperature range is 180° to 202°F (82° to 94°C).

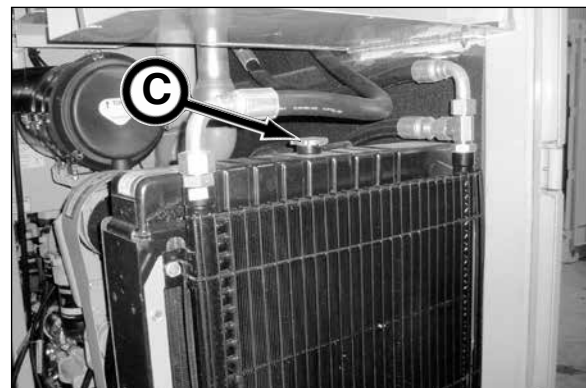

25. Shut off engine. Check coolant level and add if necessary. Check entire coolant system for leaks.

AFTER EACH DRIVE

48. CLEAN PILOT TUBES

After each drive, the pilot inner tube (A) and annular space (B) must be cleaned.

1. Clean the pilot inner tube with tube cleaner (C).
Be sure to clean the complete inner tube.

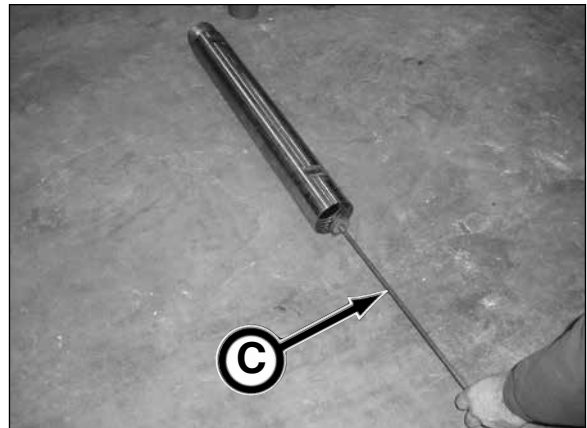
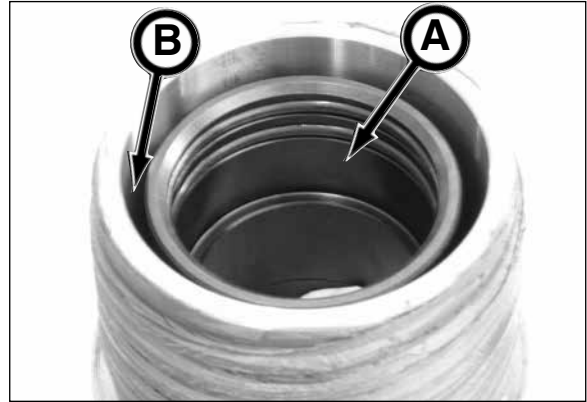

2. Install the fluid connector to the pilot tube.
3. Connect a clean water supply to the fluid connector. Use a minimum water pressure of 10 gal @ 1,000 psi (37.9 L @ 27.6 MPa).
4. Flush the pilot tube annular space while rotating the pilot tube to prevent any contaminants from settling in the pilot tube.



AFTER EVERY 2000 FEET

49. DRAIN & FILL BEARING SWIVEL OIL

1. Remove swivel cutter head casing (A) to expose the auger assembly (B).
2. Remove the check port plug (C) on bearing housing.
3. Remove the oil fill port plug (D).
4. Reposition the auger assembly until one of the ports is in the 6 o'clock position.
5. Allow oil to drain. Dispose of used oil properly.
6. Once oil is drained, install a grease fitting at the oil fill port (D) and reposition assembly with check port plug (C) in the 12 o'clock position.
7. Using the oil gun (P0126-039) filled with Mobilgear 600 XP 680 Gear Oil (**DO NOT USE GREASE**), pump the gear lube oil until the lube is at the bottom of the check port hole.

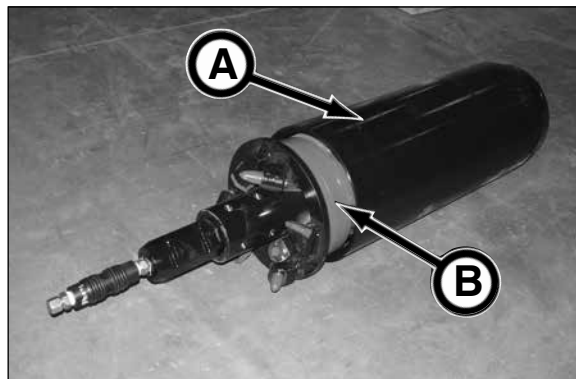

Approximate oil capacities:

11" Bearing Swivel	1.4 qts (1.3 L)
16" Bearing Swivel	2.4 qts (2.3 L)

8. Rotate swivel to work out any air and then allow the oil to settle for 10 - 15 minutes and check oil level.
9. When oil is at proper level, remove grease fitting from oil fill port and reinstall the oil fill port plug and reinstall the check port plug (C).
10. Cover check port plug (C) with silicone and allow to dry before use.

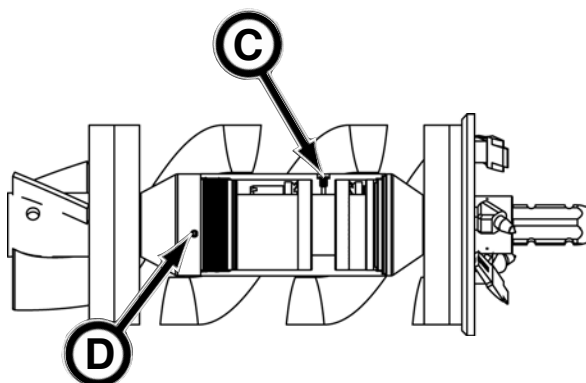

AS REQUIRED

50. INSPECT PILOT TUBE THREADS

The pilot tube threads must be cleaned and relubricated with Baker Hughes Copper Guard-4® or equivalent. This prevents dirt from damaging threads or unlubricated threads from seizing.

Using pilot tubes with unclean threads or improper lubrication will cause premature wear or damage to pilot tubes.

Be sure pilot tube cap and plugs are also cleaned to prevent dirt from adhering to pilot tube threads.

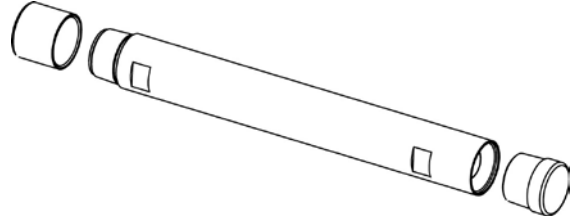

NOTICE

If there is dust or dirt in the pilot tube threads, or poor thread lubrication, a high breakout torque and thread damage will occur. This will cause damage to the reception shaft breakout tool and/or other tooling and accessories. Be sure to ALWAYS store pilot tubes with caps and plugs attached.

51. REPLACING LASER BORE SIGHT BATTERIES

⚠ DANGER

Staring into laser light will cause severe injury. Do not stare into the laser sight light beam or the laser guidance system laser light beam. Avoid direct eye exposure. Do not aim laser at anyone's eyes.

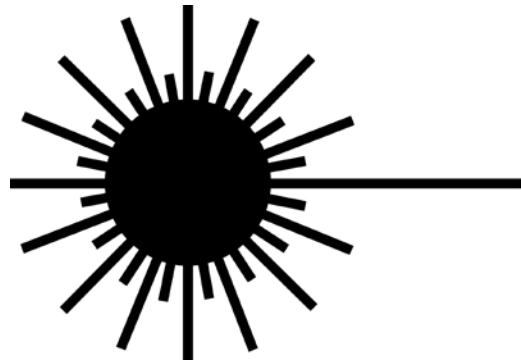

1. Remove the end cap by holding the laser chamber and turning end cap completely counterclockwise.
2. Remove the button batteries from the chamber. Examine the orientation of the batteries. The positive or + side of the batteries face towards the end cap.
3. Insert three new 392 button batteries into the laser sight with the negative side of the battery into the chamber first.
4. Replace end cap.



52. CHARGE TABLET PC BATTERY

Charge Tablet PC battery to keep the battery charged properly. Failure to fully charge battery will result in shortened battery life and cause GBM_System program to load incorrectly at start up.

Be sure to store computer between 50°F and 86°F (10°C and 30°C).

Unused or stored batteries can lose power over time. When using a computer with a battery that has not been used for awhile, connect external power to the computer and fully charge battery before booting up computer.

For more battery performance information, on the task bar located at the bottom of the tablet screen, click the start button and then click Battery Tips.

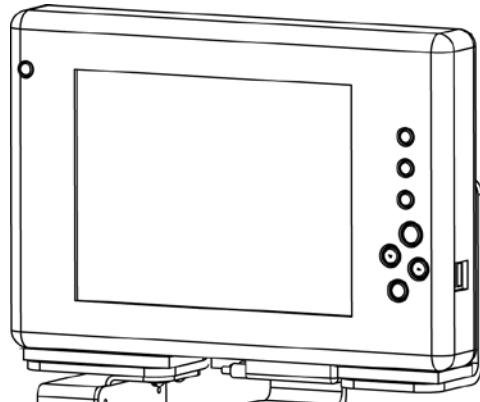

NOTES

MAINTENANCE CHARTS - POWERED CUTTER HEAD

Use the item number in the chart to refer to the detailed maintenance procedures later in this section.

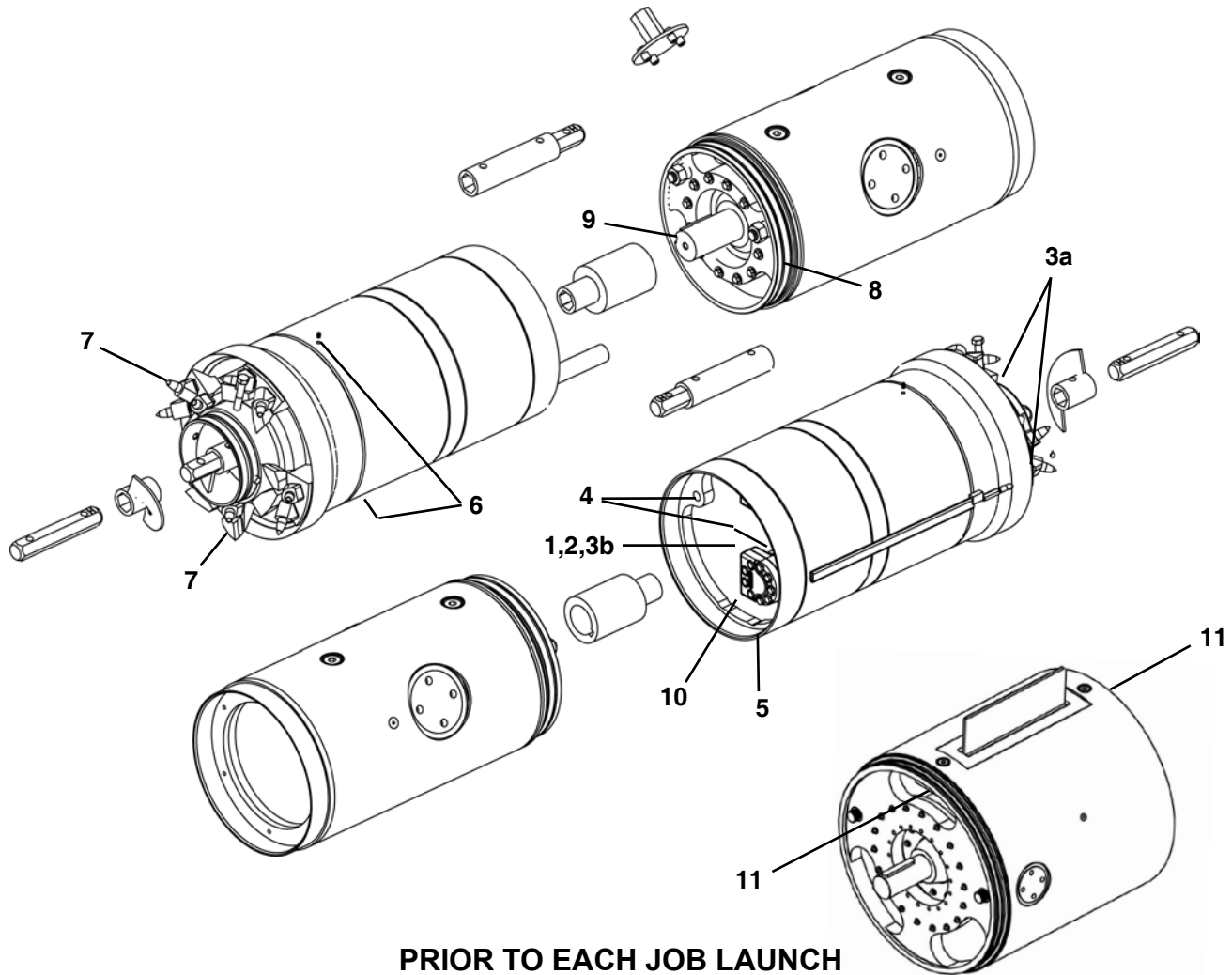

PRIOR TO EACH JOB LAUNCH

ITEM	COMPONENT	SERVICE	REQUIREMENT	MATERIAL
1.	FS Bearing Cavity	Oil sample	If oil milky or discolored, contact Akkerman Product Support	Mobil® SHC 630
2.	FS Bearing Cavity	Check oil level	Oil must flow out of check hose port.	Mobil® SHC 630
3.	FS Internal Cutter Face Seals*	Lubricate 3a-PCH20; 3b-PCH22.5+	Lubricate until grease is visible on all around cutter face plate.	Mobil® XHP222
4.	FS Alignment Pins	Lubricate	Lubricate threads	Mobil® XHP222
5.	FS Bell End	Inspect	If damaged, contact Akkerman Product Support	
6.	FS External Cutter Face Seals*	Lubricate	Lubricate until grease is visible on all around cutter face plate	Mobil® XHP222
7.	Cutter Teeth	Inspect	If damaged, replace with new.	
8.	RS O-rings	Inspect	If damaged, replace with new.	
9.	RS Auger Drive Shaft Key**	Inspect	If damaged or missing, replace with new.	PN: A43188P
10.	Jetting Hose	Install to jetting inlet port.		
11.	Dirt Wing (PCH36-44)	Lubricate (2 places)	Lubricate until grease is forced out.	Mobil® XHP222

* Lubricate seals at initial launch, then immediately after each drive while dirt is soft and flexible.

** For PCH 20, 22.5, 28.5 & PCH 44 sn 1 & 2 only

FS - Front Section

RS - Rear Section

PN - Part Number

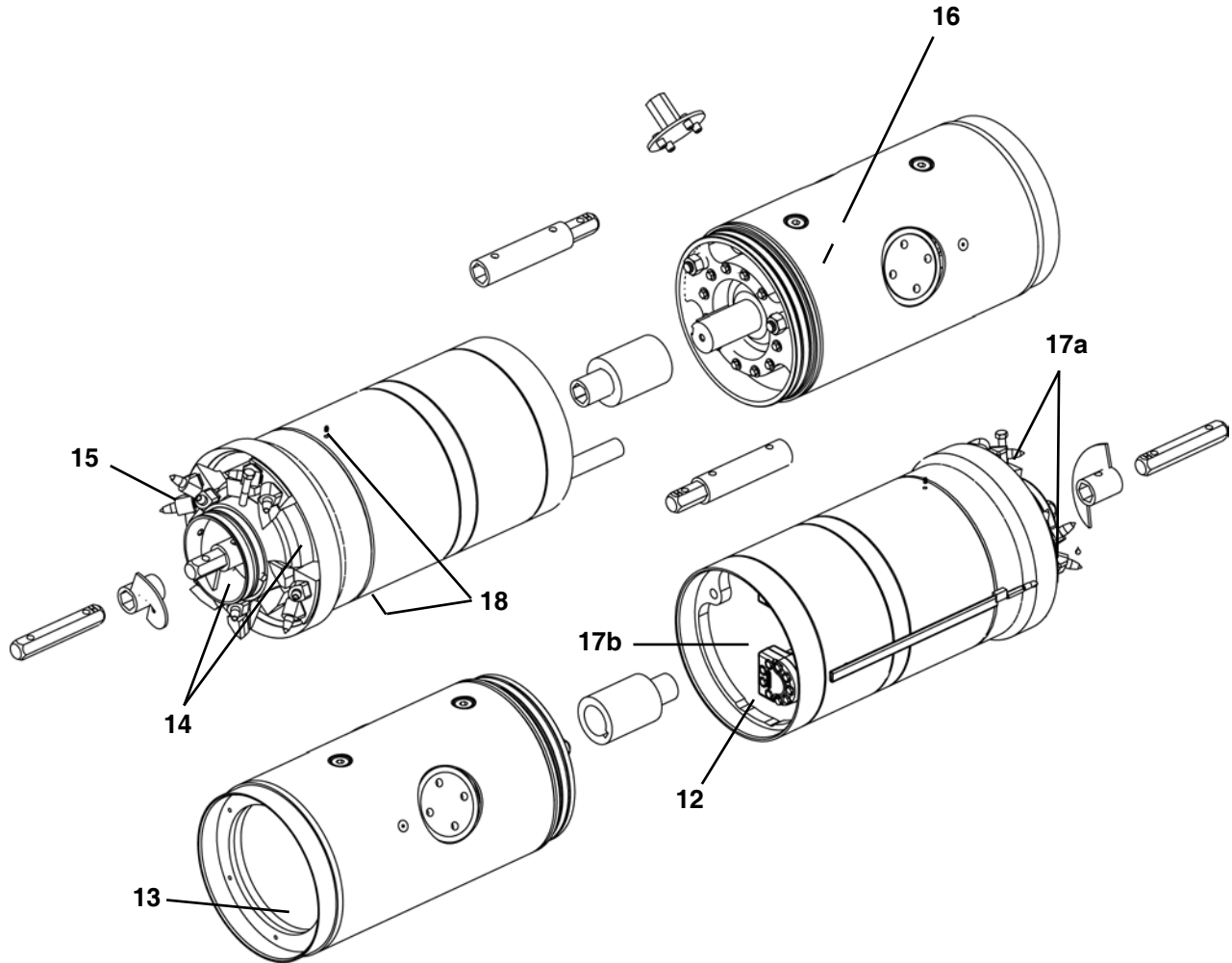

AFTER EACH DRIVE

ITEM	COMPONENT	SERVICE	REQUIREMENT	MATERIAL
12.	FS Jetting Ports	Flush	Maximum of 2,500 psi water.	Clean Water
13.	RS Lubrication Ports	Flush	Maximum of 500 psi water.	Clean Water
14.	Mixing & Frt Auger Adapter Chamber	Clean	Do not use direct water pressure.	
15.	Cutter Head Assy.	Check Mounting Bolt Torque	Tighten bolts to 90 ft-lb (Lube) torque.	
16.	Auger Drive Gear	See Maintenance Detail		
17.	FS Internal Cutter Face Seals	Lubricate	Lubricate until oil is visible on inside of cutter face plate.	Mobil® XHP222
18.	FS External Cutter Face Seals	Lubricate	Lubricate until oil is visible on outside of cutter face plate	Mobil® XHP222

FS - Front Section

RS - Rear Section

PN - Part Number

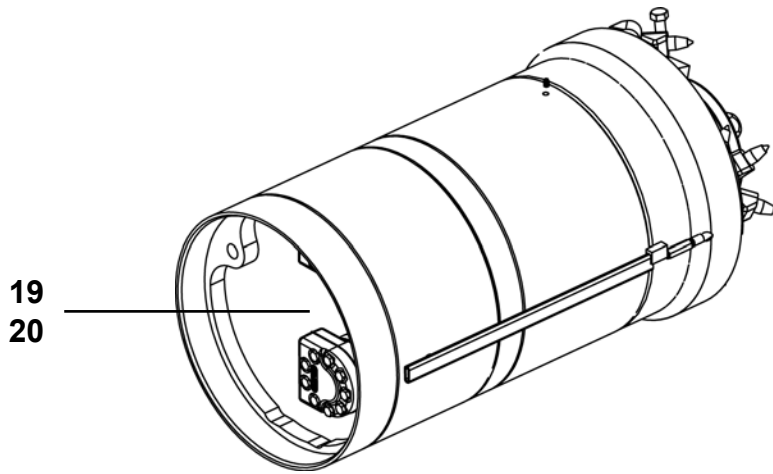

AFTER EVERY 2000 FEET

ITEM	COMPONENT	SERVICE	REQUIREMENT	MATERIAL
19.	PCH20 Front Section Bearing Cavity	Drain & Fill	Fill with new oil.	Mobil SHC 630
20.	PCH22.5 - PCH 44 Front Section Bearing Cavity	Drain & Fill	Fill with new oil.	Mobil SHC 630

PRIOR TO EACH JOB LAUNCH

1. OBTAIN FRONT SECTION BEARING CAVITY OIL SAMPLE

Test the quality of the bearing cavity oil:

1. Gain access to the check hose (A). Clean area around the check plug.
2. Remove check plug.

⚠ WARNING Suspended loads may fall and cause severe personal injury or death. Do not stand or walk under a load.

3. Obtain an oil sample. If necessary, use a pipe tong or nylon strap to lift the front section slightly off the ground. Then tip the front section of the powered cutter head until an oil sample is collected..

If the oil is milky or discolored (new oil looks similar to new 10W-30 motor oil), contact your Akkerman Product Support representative before using powered cutter head. Failure to do so WILL cause severe damage to powered cutter head.

4. Replace hose plug.

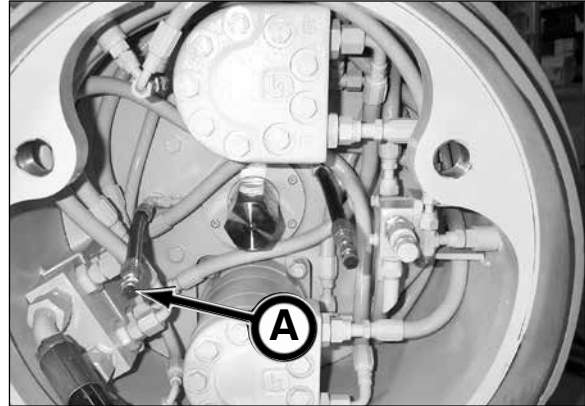

PCH 20

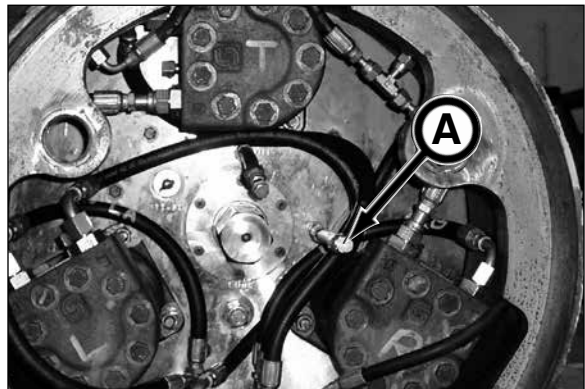

PCH 22.5

2. CHECK FRONT SECTION BEARING CAVITY OIL LEVEL

1. With alignment pin holes (B) in the horizontal position, gain access to the fill hose (C) and check hose (D) and clean area around the hose caps.
2. Remove caps from fill and check hoses.
3. Bearing cavity is at proper level when oil flows out of check hose.

If needed, add Mobil® SHC 630 Synthetic Bearing and Gear Oil through fill hose until oil flows out of check hose.

4. Replace hose caps once cavity is filled.

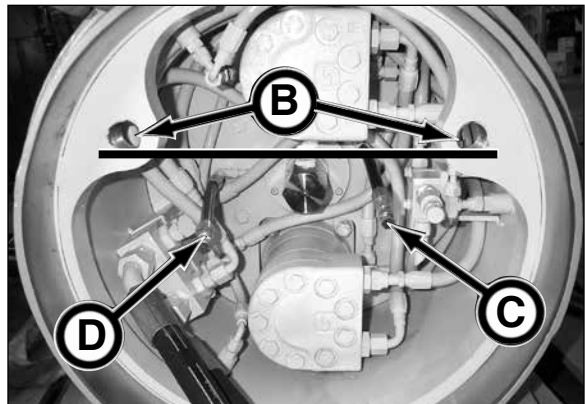

PCH 20

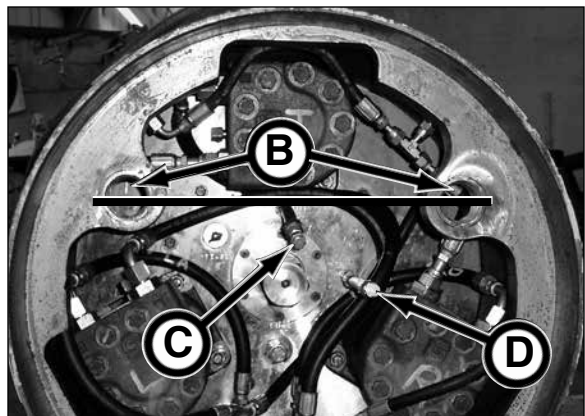

PCH 22.5 - PCH 44

3. LUBRICATE FRONT SECTION INTERNAL CUTTER FACE SEALS

NOTICE Lubricate seals at initial launch, then immediately after each drive while dirt is soft and flexible.

1. Remove hex plug to gain access to grease fitting (A) on inside cutter face of front section. The PCH 20 has 2 fittings located 180 degrees from each other on front cutter head area. The PCH 22.5 through PCH 44 have only one fitting on rear of front section.
2. Lubricate internal cutter face seals with Mobilgrease® XHP222 Premium Lubricating Grease while intermittently rotating cutter head until lubricant is visible all the way around the inside of cutter face mounting plate on front of machine.
3. Replace hex plug (s).

NOTICE Failure to replace plug WILL cause severe damage to powered cutter head.

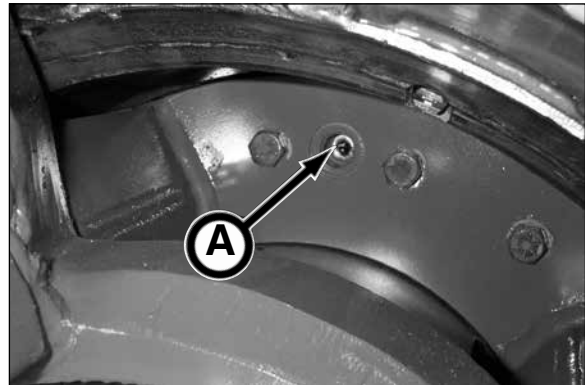

PCH 20 (2 places)

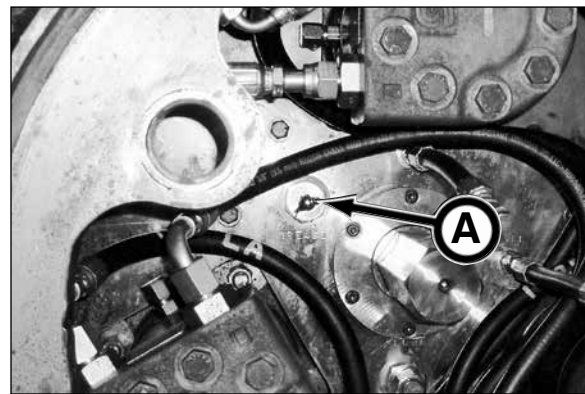

PCH 22.5 - PCH 44 (1 place)

4. LUBRICATE FRONT SECTION ALIGNMENT PINS

Lubricate alignment pin hole threads (B) with Mobilgrease® XHP222 Premium Lubricating Grease.

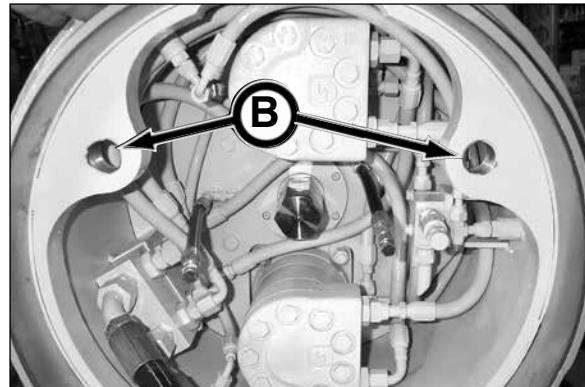

5. INSPECT FRONT SECTION BELL END

Inspect bell end (C) of front section for damage or excessive wear which may cause the front and rear sections to be improperly sealed.

Rust should be removed and must be coated with a rust prohibitor.

Contact your Akkerman Product Support representative should bell end damage occur.

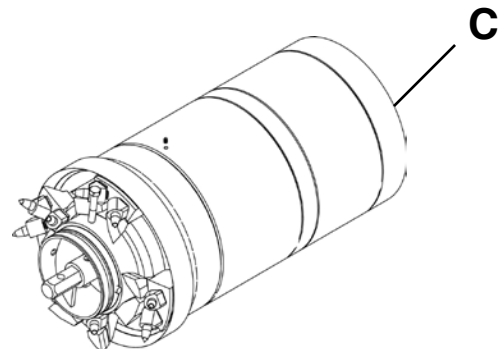

6. LUBRICATE FRONT SECTION EXTERNAL CUTTER FACE SEALS

NOTICE Lubricate seals at initial launch, then immediately after each drive while dirt is soft and flexible.

1. Remove plugs (A) at top and bottom of cutter head front section.
2. Install 1/8 NPT grease fittings.
3. Lubricate external cutter face seals with Mobilgrease® XHP222 Premium Lubricating Grease while rotating cutter head until lubricant is visible all the way around the outside of cutter face mounting plate.
4. Remove grease fittings and replace plugs.

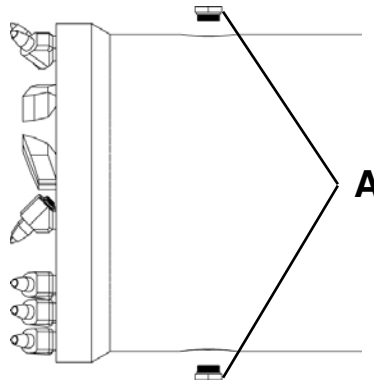

NOTICE If your powered cutter head is equipped with an increaser kit, remove plugs on increaser shell, remove plugs on cutter head body and install a 1/8 NPT grease fitting. Lubricate external cutter face seals with Mobilgrease® XHP222 Premium Lubricating Grease while rotating cutter head until lubricant is visible all the way around the outside of cutter face mounting plate. Remove grease fitting and replace plugs on cutter head body and then replace plugs on increaser shell.

7. INSPECT CUTTER BIT TEETH

Inspect cutter teeth (B) for wear or damage. Repair or replace as necessary.

NOTICE Outer teeth will wear faster than those at the center of the cutter face. Machines with an increaser kit will be more prone to wear than base sized machines.

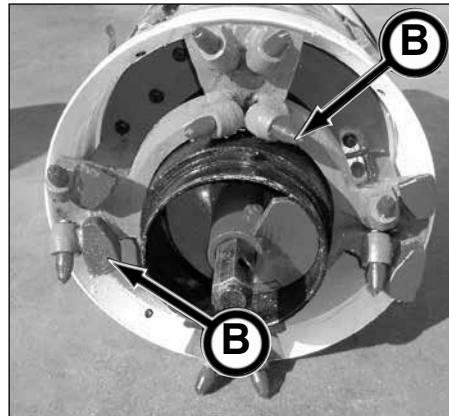

8. INSPECT REAR SECTION O-RINGS

Inspect rear section o-rings (C) for damaged. If damaged, replace with new.

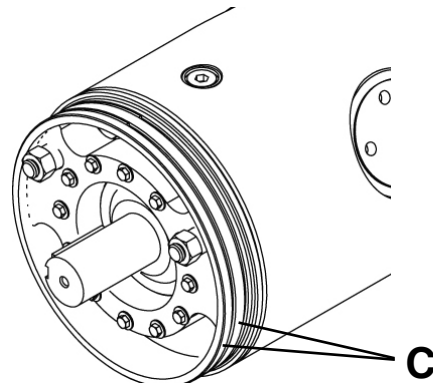

9. CHECK AUGER DRIVE SHAFT KEY ON REAR SECTION (PCH 20, 22.5, 28.5 & PCH 44 SN 1 & 2 ONLY)

The auger drive shaft key must be retained after drive is complete and available for the next drive. If key (s) (A) is missing, order Akkerman part number A43188P.

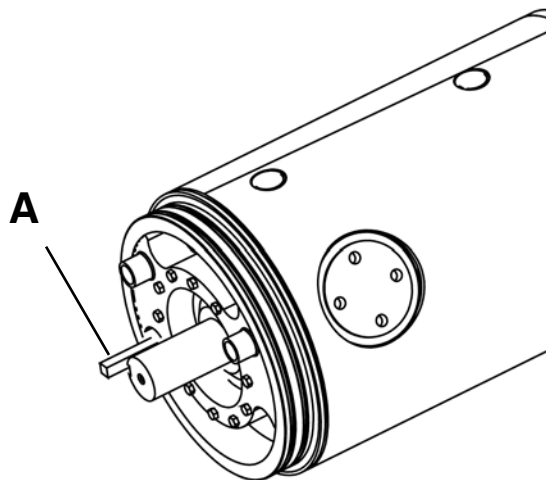

10. INSTALL JETTING HOSE TO JETTING INLET PORT

1. Install jetting hose (B) to jetting inlet port (C).
2. When launching front section, install hose to jetting supply source.
3. Once front section is launched, disconnect jetting hose from jetting supply and route jetting hose through rear section and then connect to water filter. Add additional hoses as needed.

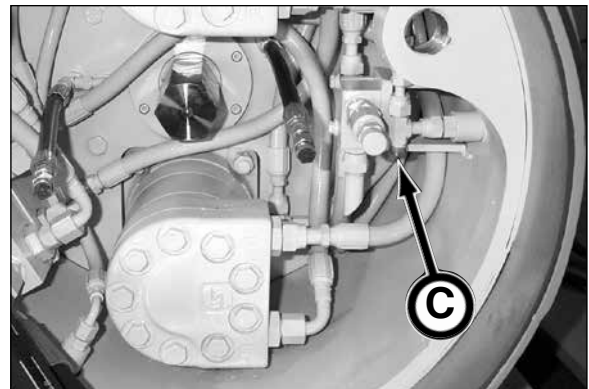

PCH 20

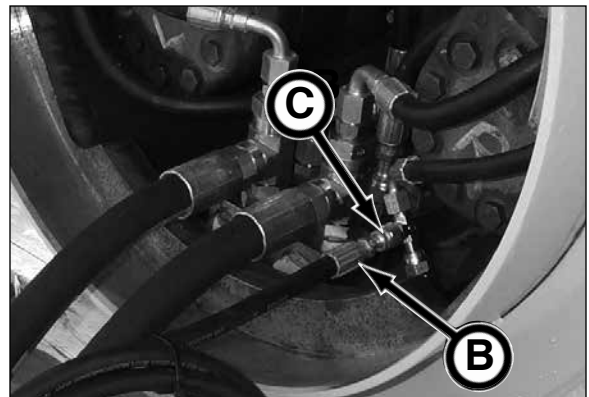

PCH 22.5

11. LUBRICATE DIRT WING (PCH36-44 ONLY)

Lubricate dirt wing (A) (2 places) with Mobilgrease® XHP222 Premium Lubricating Grease until grease is forced out

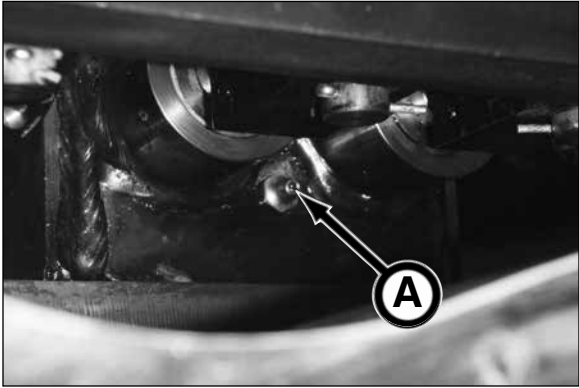

Front Fitting

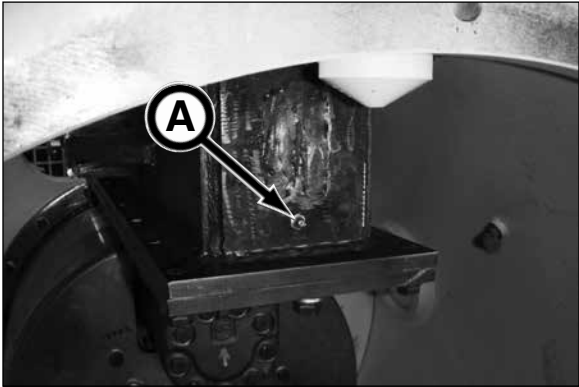

Rear Fitting

AFTER EACH DRIVE

12. FLUSH FRONT SECTION JETTING PORTS

Flush jetting ports with clean water by installing supply source to the jetting inlet port (A).

Use a maximum of 2,500 psi (17.24 MPa) water pressure. In freezing weather, use compressed air to remove water from lines after flushing to prevent machine damage.

Be sure nozzles are clean. If plugged, remove nozzles for cleaning.

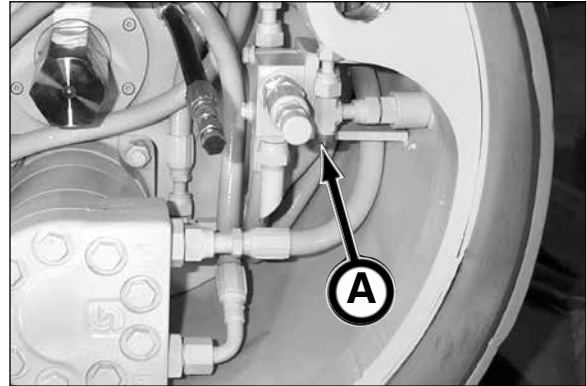

PCH 20

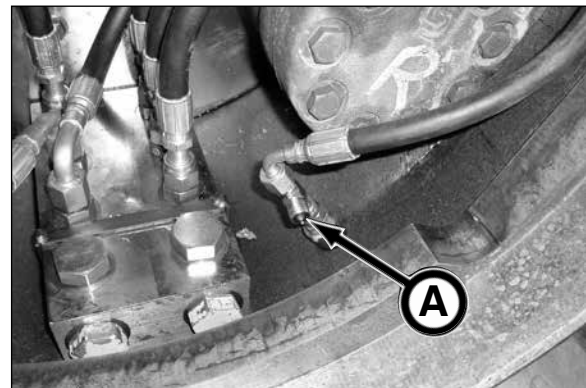

PCH 22.5

13. FLUSH REAR SECTION PIPE LUBRICATION PORTS

Flush pipe lubrication ports with clean water by installing supply source to the lubrication inlet port (B) on back of rear section.

Use a maximum of 500 psi (3,447 kPa) water pressure. In freezing weather, use compressed air to remove water from lines after flushing to prevent machine damage.



PCH 20



PCH 22.5

14. CLEAN MIXING CHAMBER & FRONT AUGER ADAPTER CHAMBER

Clean mixing chamber (A) and front auger adapter chamber (B) with water. DO NOT use direct water pressure in mixing chamber. Doing so may cause seal damage.

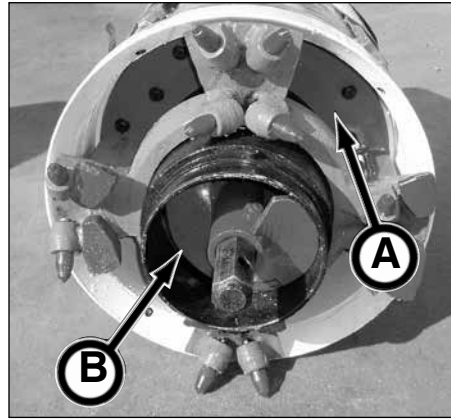

15. CHECK CUTTER HEAD ASSEMBLY MOUNTING BOLT TORQUE

Tighten ALL cutter head assembly mounting bolts (C) to 90 ft-lb (lubricated) (120 N·m) torque.

If bolts are damaged, defective, or will no longer hold the 90 ft-lb (120 N·m) torque, the bolt(s) MUST be replaced with new.

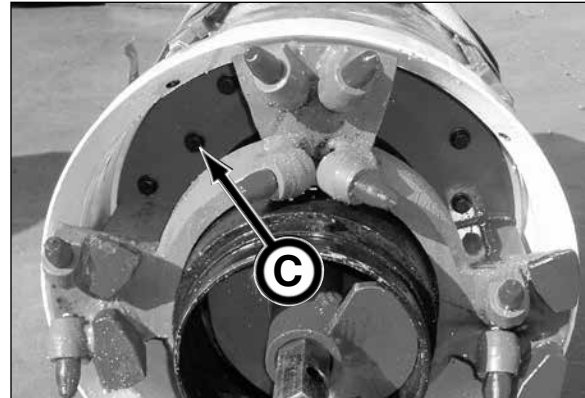

16. CHECK AUGER DRIVE GEAR BOX OIL LEVEL

PCH 20 - 22.5 - 28.5

Use a mirror to view the gear box sight gauge (C) in the rear section. Oil must be visible in sight gauge.

If necessary, remove fill cap (D) and add Mobil® SHC 630 Synthetic Bearing and Gear Oil as needed until oil is visible in the sight gauge. Replace fill cap.

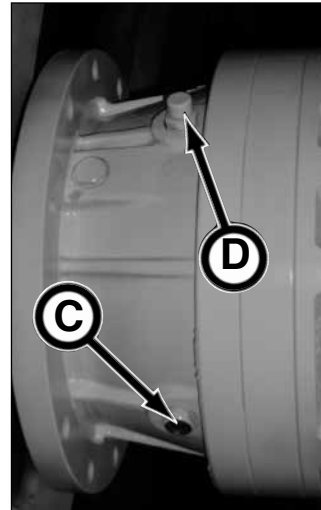

*Gear Box Removed For Photographic Purposes
PCH 20 - 22.5 - 28.5*

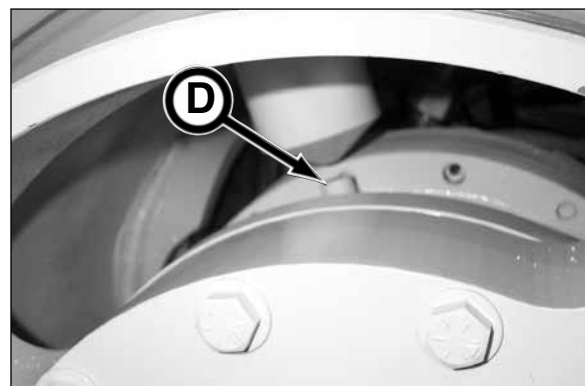

(PCH 36 - 44 continued on next page)

PCH 20 - 22.5 - 28.5

PCH 44 (sn 1 & 2 only)

Lubricate gear box seals (A) in rear section with Mobil® XHP222 or equivalent at each grease fitting (2 places).

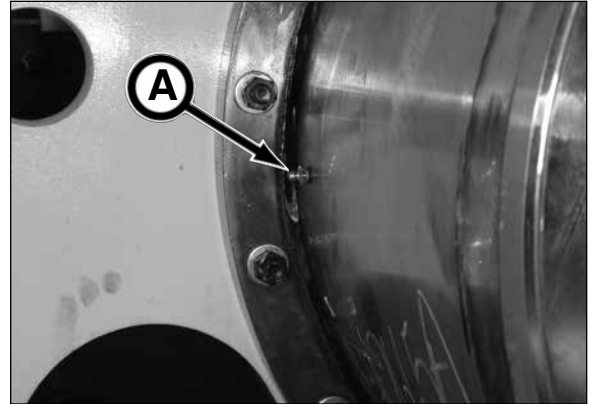

PCH 44 Left Hand Grease Fitting

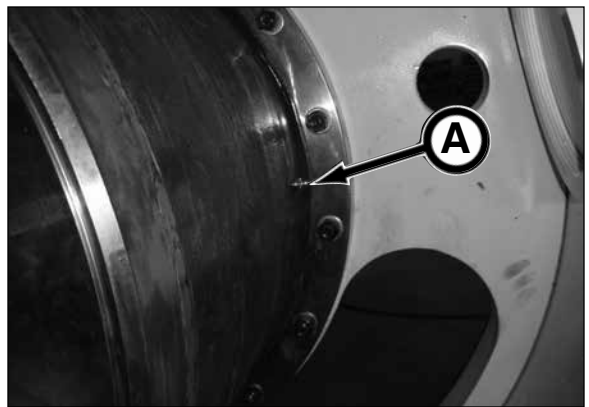

PCH 44 Right Hand Grease Fitting

PCH 36 & PCH 44 (sn 3 & after)

Check gear box oil level by removing check plug (B).

If oil does not flow out of check plug hole, add Mobil® SHC 630 Synthetic Bearing and Gear Oil into gear box oil fill port (C) until oil flows out of check plug hole.

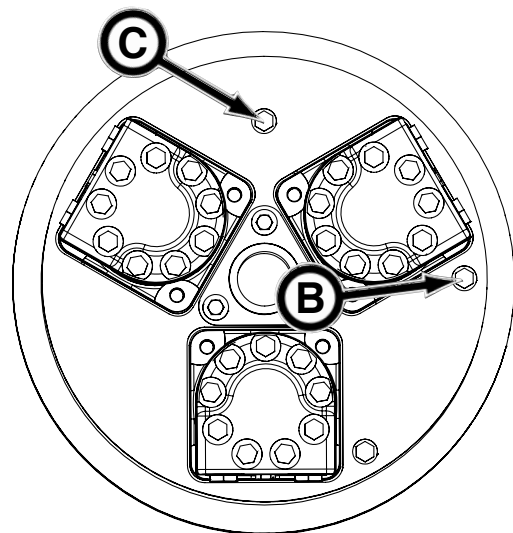

17. LUBRICATE FRONT SECTION INTERNAL CUTTER FACE SEALS

NOTICE

Lubricate seals at initial launch, then immediately after each drive while dirt is soft and flexible.

1. (PCH 20) Remove hex plug (s) to gain access to grease fitting (A) on inside cutter face of front section. The PCH 20 has 2 fittings located 180 degrees from each other on front cutter head area.

(PCH 22.5 thru PCH 44) Gain access to grease fitting (B) in front section. The PCH 22.5 through PCH 44 have only one fitting on the rear of the front section.

2. Lubricate internal cutter face seals with Mobilgrease® XHP222 Premium Lubricating Grease while intermittently rotating cutter head until lubricant is visible on the inside of cutter face mounting plate (C) on front of machine.
3. (PCH 20 only) Replace hex plug (s).

NOTICE

Failure to replace plug WILL cause severe damage to powered cutter head.

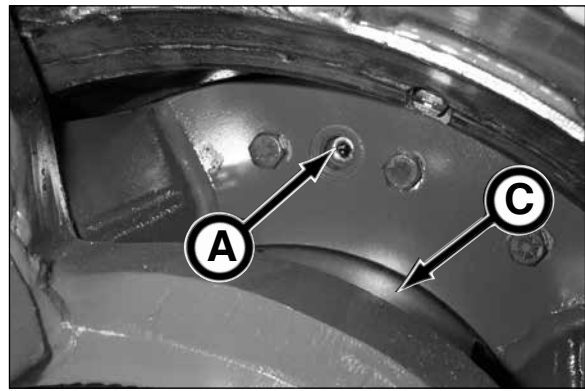

PCH 20 (2 places)

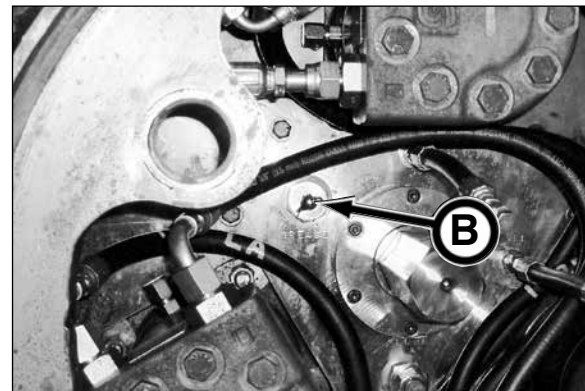

PCH 22.5 - PCH 44 (1 place)

18. LUBRICATE FRONT SECTION EXTERNAL CUTTER FACE SEALS

NOTICE

Lubricate seals at initial launch, then immediately after each drive while dirt is soft and flexible thereafter.

1. Remove plugs (D) at top and bottom of cutter head front section.
2. Install 1/8 NPT grease fittings.
3. Lubricate external cutter face seals with Mobilgrease® XHP222 Premium Lubricating Grease while rotating cutter head until lubricant is visible around outside of cutter face mounting plate.
4. Remove grease fittings and replace plugs.

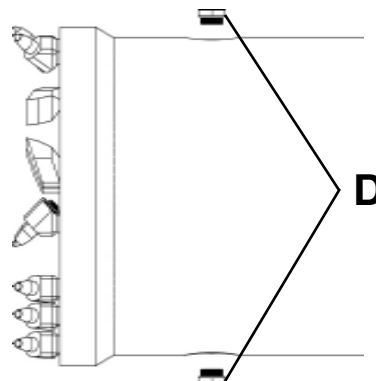

NOTICE

If your powered cutter head is equipped with an increaser kit, remove plugs on increaser shell, remove plugs on cutter head body and install a 1/8 NPT grease fitting. Lubricate external cutter face seals with Mobilgrease® XHP222 Premium Lubricating Grease while rotating cutter head until lubricant is visible around outside of cutter face mounting plate. Remove grease fitting and replace plugs on cutter head body and then replace plugs on increaser shell.

AFTER EVERY 2000 FEET

19. DRAIN & FILL FRONT SECTION BEARING CAVITY - PCH20

⚠ WARNING Suspended loads may fall and cause severe injury or death. Do not enter area under or around a suspended load.
The PCH20 front section can weigh as much as 1,900 lbs (862 kg). Be sure lifting and handling devices and blocks are capable of safely supporting the weight of the front section.



1. With the PCH front and rear sections separated, place the front section (A) in a vertical position on blocks (B) with rear end on blocks, as shown, for draining cavity oil.

IMPORTANT! The blocks MUST be capable of properly supporting the PCH.

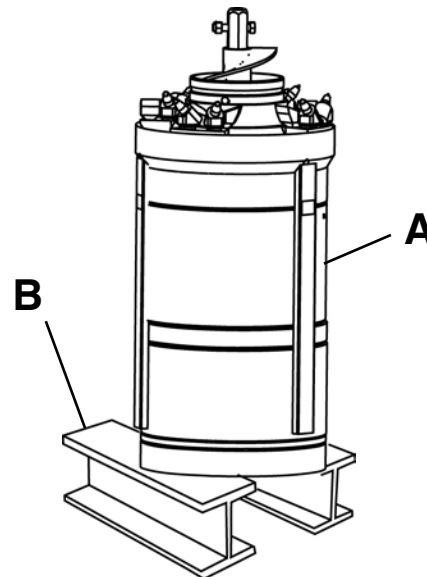

2. Place properly sized container below PCH to catch draining oil.

3. Clean area around fill and check hose caps.

4. Remove fill and check hose caps to allow the draining of the bearing cavity.

5. It is recommended to allow the bearing cavity to drain overnight.

6. Once drained, move the PCH from the blocks to its horizontal position.

7. Inspect drained oil for any signs of contamination such as milky or discolored oil (new oil looks similar to new 10W-30 motor oil). If there are signs of contamination, the mechanical shaft seal and stationary seal must be inspected for damage. Contact your Akkerman Aftermarket Support representative for more information.

8. With alignment pin holes (C) in the horizontal position, gain access to the fill hose (D) and check hose (E) and clean area around the hose caps.

9. Add Mobil SHC 630 Synthetic Bearing and Gear Oil through fill hose until oil flows out of check hose

Below are approximate bearing cavity oil capacities. Be sure to fill until oil flows out of check hose.
PCH22.5 9.5 qt (9 L)

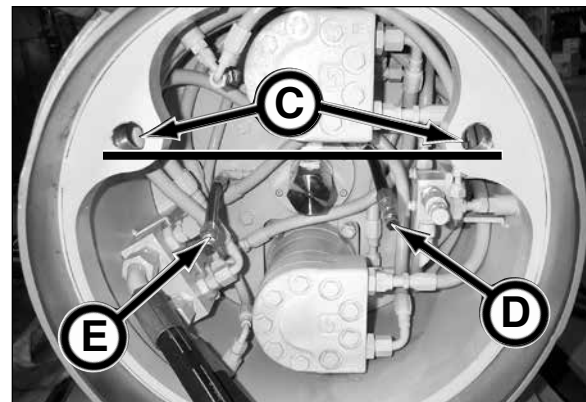

PCH 20

10. Replace fill and check hose caps.

20. DRAIN & FILL FRONT SECTION BEARING CAVITY - PCH22.5 - PCH44

1. With the PCH front and rear sections separated, clean area around the chemical discharge port (A).

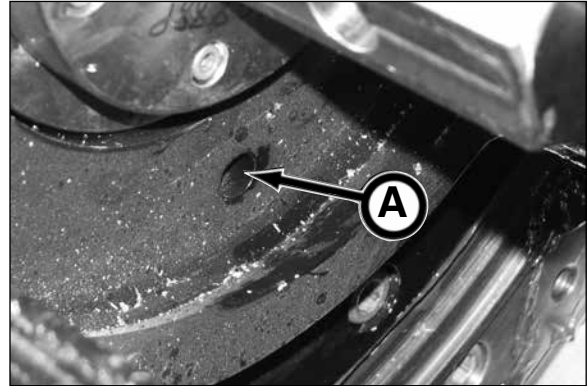

⚠ WARNING

Suspended loads may fall and cause severe injury or death. Do not enter area under or around a suspended load.

The front section can weigh as much as 6,500 to 7,000 lbs (2,948 to 3,175 kg). Be sure lifting and handling devices and blocks are capable of safely supporting the weight of the front section.



2. Place the front section (B) in a vertical position on blocks (C) with rear end on blocks, as shown, for draining cavity oil.

IMPORTANT! The blocks MUST be capable of properly supporting the PCH.

3. Place properly sized container (D) below PCH to catch draining oil.

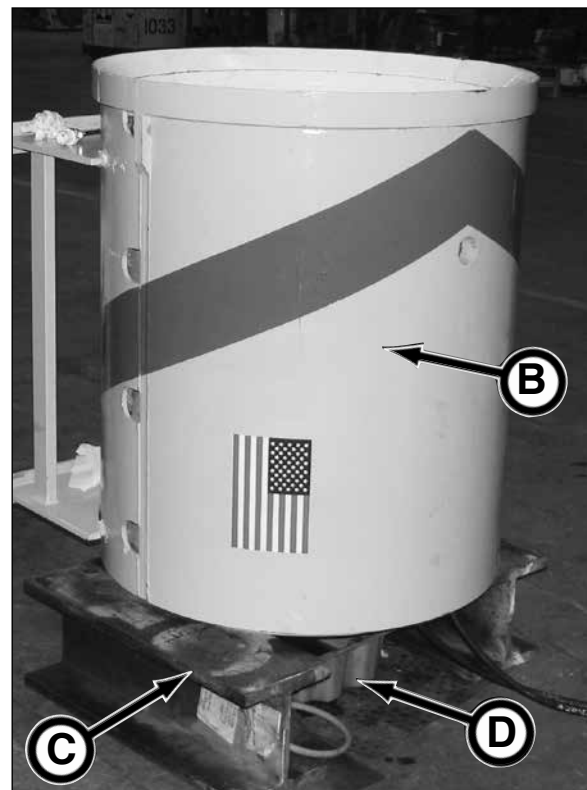

(continued on next page)

4. Remove chemical delivery tube (A).
5. Drain oil from bearing cavity. Wait at least one hour before replacing chemical delivery tube to ensure bearing cavity is properly drained.
6. Once drained, replace the chemical delivery tube.
7. Inspect drained oil for any signs of contamination such as milky or discolored oil (new oil looks similar to new 10W-30 motor oil). If there are signs of contamination, the mechanical shaft seal and stationary seal must be inspected for damage. Contact your Akkerman Aftermarket Support representative for more information.

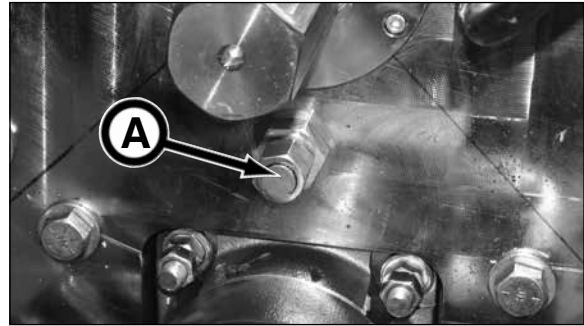

⚠ WARNING

Suspended loads may fall and cause severe injury or death. Do not enter area under or around a suspended load. The front section can weigh as much as 6,500 to 7,000 lbs (2,948 to 3,175 kg). Be sure lifting and handling devices and blocks are capable of safely supporting the weight of the front section.



8. Move the PCH from the blocks to its horizontal position.
9. With alignment pin holes (B) in the horizontal position, gain access to the fill hose (C) and check hose (D) and clean area around the hose caps.
10. Remove caps from fill and check hoses.
11. Add Mobil SHC 630 Synthetic Bearing and Gear Oil through fill hose until oil flows out of check hose.

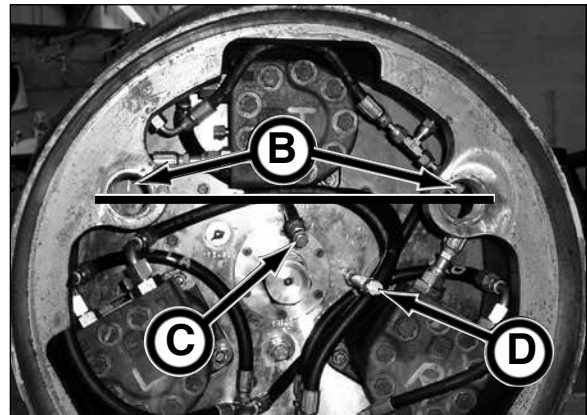

PCH 22.5 - PCH 44

Below are approximate bearing cavity oil capacities. Be sure to fill until oil flows out of check hose.

PCH22.5	12 qt (11.4 L)
PCH28.5	28 qt (26.5 L)
PCH36	49 qt (46.3 L)
PCH44	83 qt (78.5 L)

12. Replace hose caps once bearing cavity is filled.

Storage

PREPARING FOR STORAGE

1. Repair worn or damaged parts.
2. Wash all equipment thoroughly.
3. Lubricate all grease points on the Guided Boring Machine. Grease threads on bolts used for adjustments.
4. Drain auger drive oil. Add Mobil SHC 630 or equivalent until oil level flows out of check plug. Replace plugs.
5. Retract all hydraulic cylinders if possible. If not, coat exposed cylinder rods with a corrosion preventive.
6. Drain engine oil, replace filter(s) and refill engine with oil specified in Fuels & Lubricants section.
7. Drain water and sediment from fuel system. Dispose of water and sediment properly.
8. Add proper fuel stabilizer for a full tank. Fill fuel tank completely.
9. Store diesel fuel in plastic, aluminum, or steel containers specially coated for diesel fuel storage.
10. Clean air cleaner.
11. Restart engine and operate machine long enough to warm the oil. Check for leaks after machine warms up.
12. Remove battery (negative cable first) and store it in a cool, dry place. Remove corrosion from cables and battery case. Use baking soda to neutralize acid. Place battery on wood (not concrete) and connect a small trickle charger to it to maintain charge; OR charge battery every 30 days when it is in storage, if necessary.
13. Repaint equipment where necessary.
14. Drain hydraulic oil, flush oil reservoir, change hydraulic filters, and refill hydraulic reservoir. Check for leaks.
15. Change hydraulic filters and refill hydraulic reservoir. Check for leaks.
16. Wipe up lube spills. Dispose of rags and trash properly.
17. Loosen all belts.
18. If possible, store equipment under cover and out of the weather in a ventilated area.
19. If the engine will be stored over 6 months, refer to your engine manual for preparing the engine for long term storage.
20. Drain water from Powered Cutter Head.
21. Guidance system Tablet PC must be charged each month to extend battery life. Failure to do so will shorten battery life and cause GBM_System program to load incorrectly at start up.
22. Clean casings and augers to remove any material. Spray a rust inhibitor on the bell/spigot ends and hex connections.
23. Store hydraulic hoses indoors if possible to minimize UV damage and maintain a consistent ambient temperature. Note, since the hydraulic hoses are filled with hydraulic oil, and are subjected to a drastic temperature increase, the hoses could retain pressure causing them to leak or burst.
24. Clean and drain lubrication and high pressure jetting hoses. Store indoors to minimize UV damage.

REMOVING FROM STORAGE

1. Clean equipment thoroughly.
2. Check to make sure all decals including safety decals are clean and readable.
3. Check condition of wires and cables. Repair or replace as necessary.
4. Charge battery (if necessary) and install it.
5. Check coolant level. If coolant level is low, check for leaks and add coolant as required.
6. Adjust belt tension.
7. Check auger drive oil level. Add oil as needed. See Auger Drive Lubricant in Lubricants section.
8. Remove the cylinder corrosion preventive from the cylinder rods if it is not compatible with hydraulic oil or seal materials.
9. Check for leaks. Repair or replace as necessary.
10. Check hydraulic oil level. If fluid is low, check for leaks and add oil as required. See Power Pack Oil Reservoir Lubricant in Lubricants section.
11. Check condition of all hoses and connections. Tighten, repair or replace with new as needed.
12. Before operating, cycle hydraulic functions several times to purge air from the hydraulic system.
13. See your engine manual on how to restore engine to service.
14. If diesel fuel is stored for more than a month prior to use, or there is a slow turnover in fuel tank or supply tank, add a fuel conditioner or equivalent to stabilize the fuel and prevent water condensation.
15. Charge guidance system tablet PC battery.
15. Review this Operator's Manual.

Troubleshooting

Guided Boring Machine

Problem	Cause	Solution
No power to guidance system.	Switch on control pendant is OFF.	Turn switch ON.
	Connections are loose or disconnected.	Secure all connections.
	Blown monitor fuse.	Replace fuse.
	Voltage is less than 10 VDC.	Check voltage.
Valve functions (jacking, rotation, travel) do not operate.	Power pack engine is not running.	Start up engine.
	Insufficient oil in hydraulic reservoir.	Check oil level and fill as needed.
	Quick couplers are not properly connected.	Connect quick couplers on gear box properly.
	No oil flow.	Open inlet valve on power pack.
	Low oil in reservoir.	Fill reservoir.
	Disconnect disengaged on load sense circuit.	Properly connect load sense hose to jacking frame.
	Load sense filter clogged.	Replace load sense filter.
Valve bank leaking.	Tank disconnect not connected.	Properly connect tank hose to jacking frame.
	Valve cap on opposite end of lever is deformed.	Replace seal/cover.
Hydraulic make-up tool operates incorrectly.	Hoses are installed in wrong port.	Switch hoses.
Break-out tool does not operate.	Break-out tool is unplugged.	Plug in break-out tool.
	Quick disconnect is not fully connected.	Secure quick disconnect.
	Power source defective.	Repair power source.
	Defective switch on controller.	Replace switch.
Lack of hydraulic power at tool.	High oil temperature (above 150°F (66°F))	Cool oil to operating temperature.
		Change hydraulic oil to higher viscosity.

Power Pack Engine

NOTICE

Before troubleshooting the engine, first retrieve any fault codes on the diagnostic gauge display and perform the corrective actions (refer to your engine operator's manual). If any problems remain, use the following troubleshooting.

Problem	Cause	Solution	
Engine cranks but will not start.	Incorrect starting procedure.	Verify correct starting procedure.	
	No fuel.	Check fuel in tank. Open fuel shut-off valve.	
	E-Stop is engaged.	Release E-Stop.	
	(P275T Only) Hydraulic suction valve not fully open.	Completely open suction valve.	
	Exhaust restricted.	Check and correct restriction.	
	Fuel filter plugged or full of water.	Replace fuel filter and/or drain water from filter.	
	Injection pump not getting fuel or air in fuel system.	Bleed fuel system.	
	Faulty injection pump or nozzles.	Consult authorized diesel repair for repair or replacement.	
	Engine hard to start or will not start.	Engine starting under load.	Disengage load.
		Improper starting procedure.	Review starting procedure.
Low battery voltage.		Charge or replace battery.	
No fuel.		Check fuel in tank. Open fuel shut-off valve.	
Air in fuel line.		Bleed fuel system.	
Cold weather.		Use cold weather starting procedure.	
Slow starter speed.		See "Starter Cranks Slowly."	
Crankcase oil too heavy.		Use proper oil viscosity.	
Improper type of fuel.		Consult fuel supplier.	
Clogged fuel filter(s).		Replace filter element(s).	
Water, dirt, or air in fuel system.		Drain, flush, fill, and bleed fuel system.	
Dirty or faulty injection nozzles.		Consult authorized dealer.	
Defective glow plugs (Cold weather starting).		Test glow plugs. Refer to engine manual, 24 month maintenance.	
Electronic fuel system problem.		Consult qualified engine dealer.	
Engine knocks.		Low engine oil level.	Add oil to engine crankcase.
	Low coolant temperature.	Remove and check thermostat.	
	Engine overheating.	See "Engine Overheats."	
	Engine cold.	Wrong or defective thermostat. Remove and check thermostat.	

(continued on next page)

Power Pack Engine (continued)

Problem	Cause	Solution
Abnormal Engine Noise		
<p>NOTICE Variable geometry turbocharger recycles after starting engine, causing a momentary revving sound in the engine. This is normal. Do not confuse the whine heard during turbocharger run down with noise which indicates a bearing failure. The whine heard during turbocharger run down is normal.</p>		
	Worn main or connecting rod bearings.	Determine bearing clearance. Consult qualified engine dealer.
	Excessive crankshaft end play.	Check crankshaft end play. Consult qualified engine dealer.
	Loose main bearing caps.	Check bearing clearance. Consult qualified engine dealer.
	Worn connecting rod bushings and piston pins.	Inspect pins and bushings. Consult qualified engine dealer.
	Scored pistons.	Inspect pistons. Consult qualified engine dealer.
	Worn timing gears or excess backlash.	Check timing gear backlash. Consult qualified engine dealer.
	Excessive valve clearance.	Check & adjust valve clearance. Consult qualified engine dealer.
	Worn camshaft lobes.	Inspect camshaft. Consult qualified engine dealer.
	Worn rocker arm shaft(s).	Inspect rocker arm shafts. Consult qualified engine dealer.
	Turbocharger bearings not lubricated (insufficient oil pressure)	Determine cause. Consult qualified engine dealer.
Engine runs irregularly or stalls frequently.	Low coolant temperature.	Remove and check thermostat.
	Clogged fuel filter(s).	Replace filter element(s).
	Low battery voltage.	Charge or replace battery. Check alternator, replace.
	Water, dirt, or air in fuel system. fuel system.	Drain, flush, fill, and bleed
	Dirty or faulty injection nozzles.	Consult qualified engine dealer.
	Electronic fuel system problem.	Consult qualified engine dealer.
Below normal engine temperature.	Defective thermostat.	Remove and check thermostat.
	Defective temperature gauge or sender.	Check gauge, sender, and connections.

(continued on next page)

Power Pack Engine (continued)

Problem	Cause	Solution
Lack of power.		
NOTICE	Exhaust gas recirculating valve will recycle occasionally, causing a momentary loss of speed. This is normal.	
	Engine overloaded.	Reduce load on engine.
	Intake air restriction.	Service air cleaner.
	Clogged fuel filter(s).	Replace fuel filter(s).
	Improper type of fuel.	Use proper fuel.
	Overheated engine.	See "Engine Overheats."
	Below normal engine temperature.	Remove and check thermostat.
	Improper valve clearance.	Consult qualified engine dealer.
	Dirty or faulty injection nozzles.	Consult qualified engine dealer.
	Injection pump out of time.	Consult qualified engine dealer.
	Electronic fuel system problem.	Consult qualified engine dealer.
	Turbocharger not functioning.	Consult qualified engine dealer.
	Leaking exhaust manifold gasket.	Consult qualified engine dealer.
	Restricted fuel hose.	Clean or replace fuel hose.
	Low fast idle speed.	Consult qualified engine dealer.
Low oil pressure.	Low oil level.	Add oil.
	Improper oil type.	Drain, fill crankcase with proper oil and quantity.
High oil consumption.	Crankcase oil too light.	Use proper oil.
	Oil leaks.	Check for leaks in lines, gaskets, and drain plug.
	Restricted crankcase vent tube.	Clean vent tube.
	Defective turbocharger.	Consult qualified engine dealer.
Engine emits white smoke.	Improper type of fuel.	Use proper fuel.
	Low engine temperature.	Warm up engine to normal operating temperature.
	Defective thermostat.	Remove and check thermostat.
	Defective injection nozzles.	Consult qualified engine dealer.
	Defective glow plugs.	Consult qualified engine dealer.

(continued on next page)

Power Pack Engine (continued)

Problem	Cause	Solution
Engine emits black or gray exhaust smoke.	Improper type of fuel.	Use proper fuel.
	Clogged or dirty air cleaner.	Service air cleaner.
	Engine overloaded.	Reduce load on engine.
	Injection nozzles dirty.	Consult qualified engine dealer.
	Electronic fuel system problem.	Consult qualified engine dealer.
	Turbocharger not functioning.	Consult qualified engine dealer.
Engine overheats.	Doors closed on power pack.	Open all power pack doors.
	Engine overloaded.	Reduce load on engine. Open container door.
	Low coolant level.	Fill radiator to proper level and check for leaks or loose connections.
	High hydraulic oil temperature.	Open container door.
	Faulty radiator cap.	Have a technician check.
	Drive belt loose or defective.	Check automatic belt tensioner and check belts for stretching. Replace as required.
	Low engine oil level.	Add oil as needed.
	Cooling system requires flushing.	Flush cooling system.
	Defective thermostat.	Remove and check thermostat.
	Defective temperature gauge or sender.	Check coolant temperature with thermostat and replace if needed.
High fuel consumption.	Incorrect grade of fuel.	Use correct grade of fuel.
	Clogged or dirty air cleaner.	Service air cleaner.
	Engine overloaded.	Reduce load on engine.
	Improper valve clearance.	Consult qualified engine dealer.
	Injection nozzles dirty.	Consult qualified engine dealer.
	Electronic fuel system problem.	Consult qualified engine dealer.
	Defective turbocharger.	Consult qualified engine dealer.
	Low engine temperature.	Check thermostat.
	Low relief pressure.	Raise pressure relief so relief is 200 psi above pressure compensator setting.

(continued on next page)

Power Pack Engine (continued)

Problem	Cause	Solution
Undercharged system.	Excessive electrical load from added accessories.	Remove accessories or install higher output alternator.
	Excessive engine idling.	Increase engine rpm when heavy electrical load is used.
	Poor electrical connectors on battery, ground strap, starter, or alternator.	Inspect and clean or replace as necessary.
	Defective battery.	Test battery.
	Defective alternator.	Test charging system. Replace alternator.
Battery uses too much water.	Cracked battery case.	Replace battery.
	Defective battery.	Test battery. Replace if needed.
	Battery charging rate too high.	Test charging system.
Battery will not charge.	Loose or corroded connections.	Clean and tighten connections.
	Sulfated or worn out battery.	Replace battery.
	Drive belt loose or defective.	Replace belt.
	Defective belt tensioner.	Replace tensioner.
Starter will not crank.	Loose or corroded connections.	Clean and tighten connections.
	Low battery output voltage.	Consult qualified engine dealer.
	Faulty start circuit relay.	Consult qualified engine dealer.
	Blown main system fuse.	Replace fuse.
Starter cranks slowly.	Low battery output.	Consult qualified engine dealer.
	Crankcase oil too heavy.	Use proper oil.
	Loose or corroded connections.	Clean and tighten connections.
Starter and hour meter functions; rest of electrical system does not function.	Blown fuse.	Replace fuse.
Entire electrical system does not function.	Loose or faulty battery connection.	Clean and tighten connections.
	Worn out battery.	Replace battery.

Powered Cutter Head (PCH)

Problem	Cause	Solution
High auger torque or auger slow.	Too many spoils.	Reduce advance rate of PCH. Add water to spoils.
	Sticky spoils.	Add water/polymer to spoils.
	Long drive length.	Add polymer to reduce load.
	Improper connections on quick disconnects.	Check to be sure all connections on quick disconnects are fully engaged.
Cutter head operating pressure too high.	Advance rate too fast.	Slow advance rate.
	No water.	Use jetting.
	No polymer in water at jetting.	Add polymer to water jetting.
	Spoils are sticky/dry.	Increase jetting psi.
	Improper connections on quick disconnects.	Check to be sure all connections on quick disconnects are fully engaged.
Casings rotate from 12 o'clock position.	Running cutter head in one direction only.	Run cutter bit in opposite direction until casing is in original 12 o'clock position. Operate cutter bit in opposite direction on every other pipe.
	Temporary casing not timed with product pipe.	Add 1' or 2' section of product pipe behind PCH.
Oil leaking in PCH valve second section.	Case drain reliefs dumping out due to high return pressure.	Operate at slower speed, reduced volume.
	Oil too cold.	Operate at lower gpm until oil is warm.
Thrust not advancing while operating cutter head.	Thrust psi higher than cutter head pressure.	Position control of cutter at mid stroke to limit flow to cutter head or until thrust advances.

Tablet PC

Problem: **Computer Stops Responding**

1. Check for any power disruption with the generator (if used), power pack, and/or tablet PC. Power is properly connected if both the tablet PC power indicator (A) and the camera power indicator (B) lights are illuminated.
2. Check to be sure the camera and power cables are in good condition and are properly connected without kinks. Kinked or damage cables WILL cause image to freeze or lock up. Replace damaged cables.
3. Press PC control buttons (Select Up, Select Down, etc) on computer to check if they operate.
4. If buttons do work, quit program and restart program. It is not necessary to restart the computer. Restarting the computer will result in a needless time delay.
5. If buttons still do not work, you must perform a Hard Power Down (see On & Off Control in section 6, Operation, sub section Guidance System - Tablet PC Start Up & Operation) using POWER button (C).
6. Restart computer (press power button for one second).
7. If problems continue, the hardware acceleration may require adjustment. Refer to steps 8 through 11.
8. Click Start Button on task bar. Click Settings. Click Control Panel. Click Display.
9. In the Display Properties window, click Settings tab, Advanced tab, and finally the Troubleshoot tab.
10. Move Hardware Acceleration slider bar (D), one setting to the left towards None.
11. Once set, click OK.

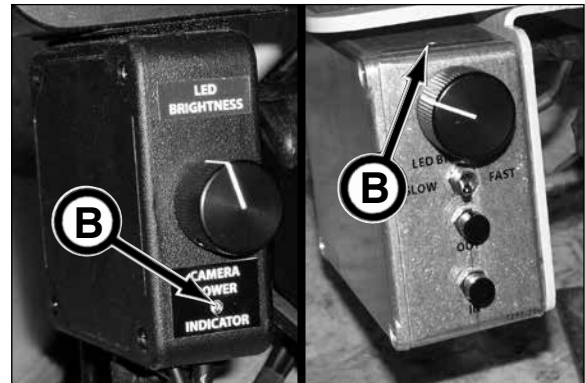
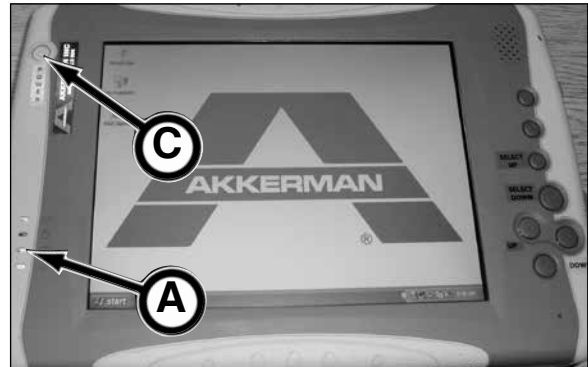

(SN FA42035F-86
& Before)

(SN FA42035F-87
& After)

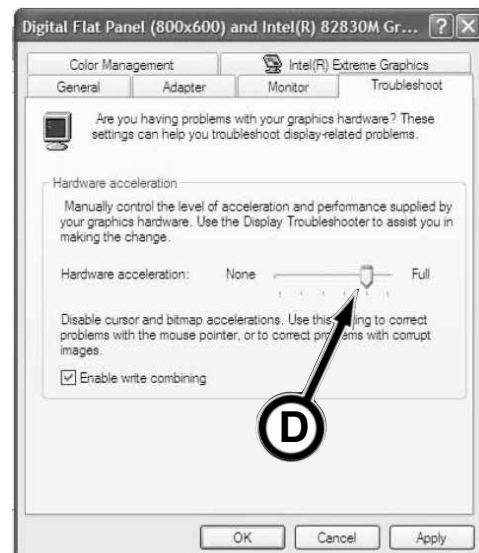

NOTICE Readjusting the hardware acceleration from Full position towards None, will slow the display rate of the moving GBM target.

Tablet PC (continued)

Problem:

Image Freezes But Function Keys Operate

1. Check to be sure the camera and power cables are in good condition and are properly connected without kinks. Kinked or damage cables WILL cause image to freeze or lock up. Replace damaged cables.

NOTICE

Power is connected properly when both the tablet PC power indicator and camera power indicator lights are illuminated.

2. With GBM_System program running, press Select Down button (A) until Status field (B) is highlighted.
3. Press UP button (C) to "Quit?".
4. Click Select Down (A) to enter.
5. With GBM program icon highlighted, press Select Down button again to view a live digital video image.
6. If image is still frozen, close program by tapping pen on in upper right-hand corner of program window, then restart program and repeat steps 2 through 5.
7. If image continues to be frozen after performing step 6, or a "No Camera Present" window appears with the camera connected, close GBM_System program and restart the computer.

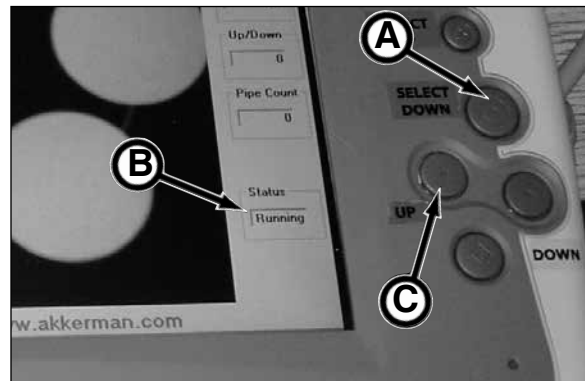

8. If problems continue, the hardware acceleration may require adjustment. Refer to steps 9 through 12.
9. Click Start Button on task bar. Click Settings. Click Control Panel. Click Display.
10. In the Display Properties window, click Settings tab, Advanced tab, and finally the Troubleshoot tab.
11. Move Hardware Acceleration slider bar (D), one setting to the left towards None.

NOTICE

Readjusting the hardware acceleration from Full position towards None, will slow the display rate of the moving GBM target.

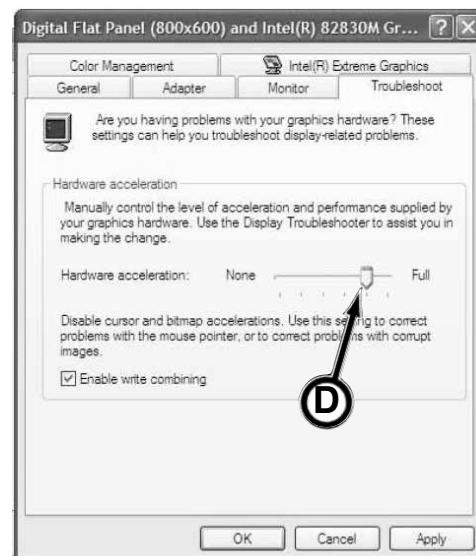

12. Once set, click OK.

Tablet PC (continued)

Problem:
Camera Is Not Recognized

NOTICE

If connecting new camera to computer for the first time, refer to Connecting New Camera to Computer in section 3, Operation.

1. Disconnect and reconnect camera power.
2. Gain access to Task Bar and click Start Button on task bar.
3. Click Settings, then Control Panel. Your computer may list the Control Panel directly from the Start Menu.
4. Double click System icon (A).
5. In the System Properties window, click the Hardware tab (B).
6. Click Device Manager button (C).
7. In the Device Manager window, click the + on the Imaging devices line to expand its contents. A Lumenera USB 2.0 Camera or Unconfigured Camera line (D) will appear.

NOTICE

Camera may appear under "USB devices" as an "Unconfigured device."

8. If camera does not respond, there will be a yellow ! (exclamation mark) in front of Lumenera USB 2.0 Camera or Unconfigured Camera line. If so, right click on the Lumenera USB 2.0 Camera line and click Properties.
9. In the Lumerera USB 2.0 Properties window, click the Driver tab (E).

(continued on next page)

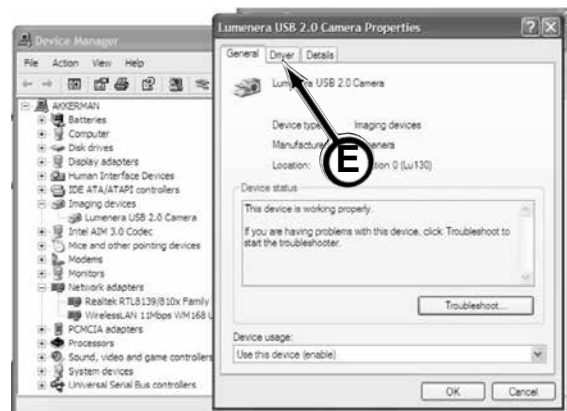
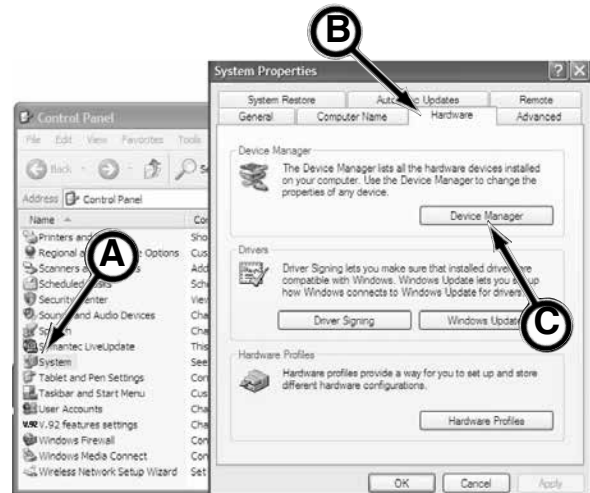

Tablet PC (continued)

Problem:

Camera Is Not Recognized (continued)

10. Click Update Driver (B).

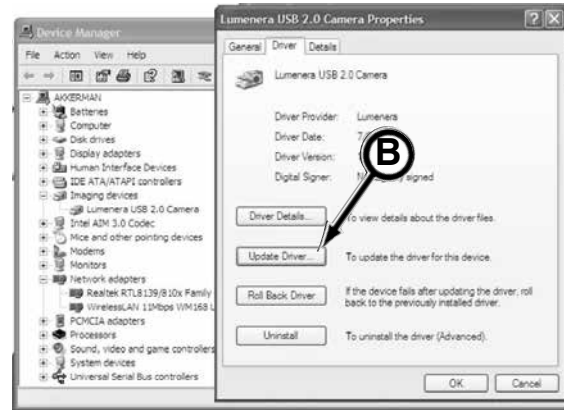

11. The wizard then appears with a “Can Windows connect to Windows Update to search for Software?” Click the “No, not this time” button (C), then click NEXT.



12. On the question “What do you want the wizard to do?” Click on Install the software automatically (Recommended) (D) and click NEXT. A window will appear that the driver has not been signed. Click continue anyway.



13. Continue to follow instructions as indicated in the windows.

14. Computer will need to be rebooted after installing camera driver.

15. If camera is still not recognized, contact your Akkerman Product Support representative.

Tablet PC (continued)

Problem:
Checking Guidance System Camera Connections

1. Start generator (if used) and power pack.
2. (P275 SN 1 - 4 Only) Flip the pendant 12V To Monitor & Control Panel switch (A) to the ON position.

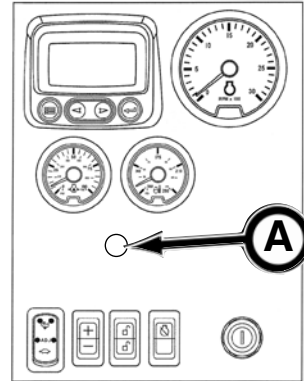

NOTICE On the P150Q Power Pack and P275 Power Pack SN 5 and after, the pendant is not equipped with the 12V To Monitor & Control Panel switch (A). As soon as the power pack engine starts, the monitor and control panel switch are automatically turned on.

3. Turn ON tablet PC by pressing power button (B).
4. Check the following:
 - a. Is the power indicator light (C) on the tablet PC illuminated? If not, either the generator or the power pack is not running, the 12V To Monitor switch is off, the power cable from pendant to Power In connection on tablet PC is not connected properly, or cable is damaged.

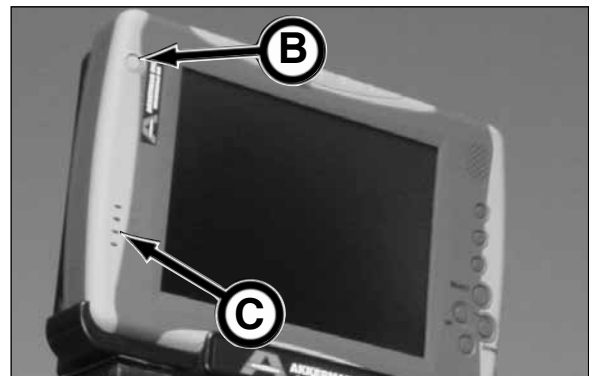

- b. (Some models) Is the Camera Power Indicator light (D) on the control box of the tablet PC assembly luminated? If not, properly install camera cable connections, or replace damaged cable.
5. If camera still fails to function properly, refer to other troubleshooting options in this section.

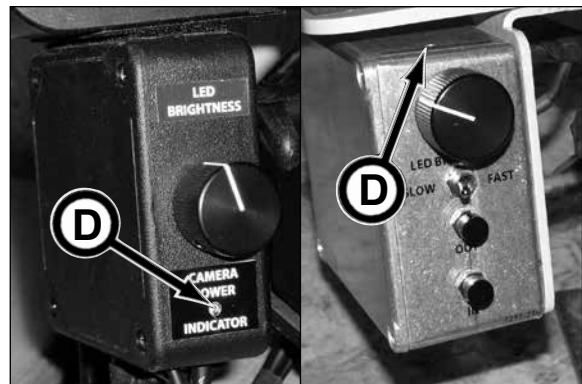

(SN FA42035F-86 & Before)

(SN FA42035F-87 & After)

Tablet PC (continued)

Problem:
No Camera Present

With power connected to tablet PC (power indicator on tablet PC is illuminated) a “No Camera Present” window (A) appears.

1. The Camera Power Indicator light (B) on control box is not illuminated.
2. Plug in camera power. The camera power indicator light is now illuminated.
3. Click Retry (C) on “No Camera Present” window and the GBM_System program (D) will automatically start up.
4. If camera still fails to function properly, refer to other troubleshooting options in this section.

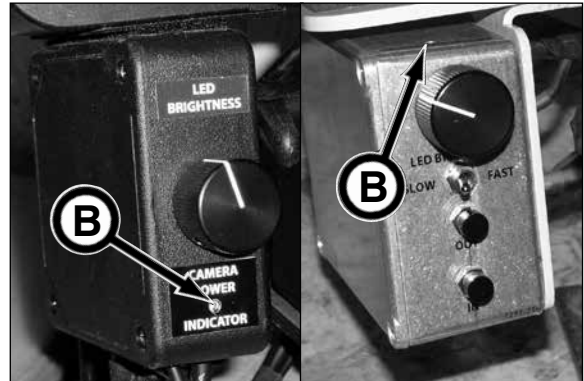
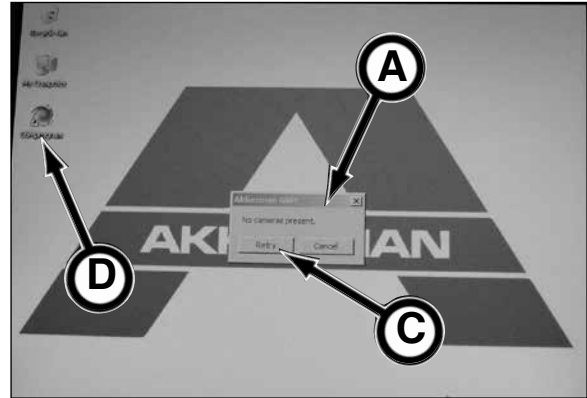

(SN FA42035F-86
& Before)

(SN FA42035F-87
& After)

Tablet PC (continued)

Problem:

Windows operating system and the Akkerman GBM_System program does not load. A DOS screen appears.

When the Tablet PC battery power becomes too low, a DOS screen (A) will appear, therefore preventing the Windows operating system and GBM_System program from loading properly. If this should occur, perform the following procedure:

1. Supply power to the Tablet PC. This will charge the battery while the computer is on.

If the computer battery will not take a charge (indicated by an orange light never changing to the green light on the computer or disconnecting external power and the computer shuts down), the computer battery must be replaced. Contact your Akkerman Product Support representative for more information.



NOTICE The DOS screen shown may or may not appear like the screen on your computer.

2. Touch the digitizing pen anywhere on the tablet PC screen. This will pop up the green F1 and F2 function buttons.
3. Click F2 button (B) to load the Windows operating system and the Akkerman GBM_System program.



NOTICE Do not click the F1 button. Doing so will take you to the BIOS (Basic Input/Output System) settings. Only an experienced computer technician should change the BIOS settings. Changes to the BIOS settings will affect the operation of the computer and other devices, such as the camera.

NOTICE Charge Tablet PC battery at least once a month to keep the battery properly charged. Failure to do so will result in shortened battery life and cause programs to load improperly.

NOTES

HYDRAULIC SCHEMATIC - GBM 4812A (PART 1 OF 2)

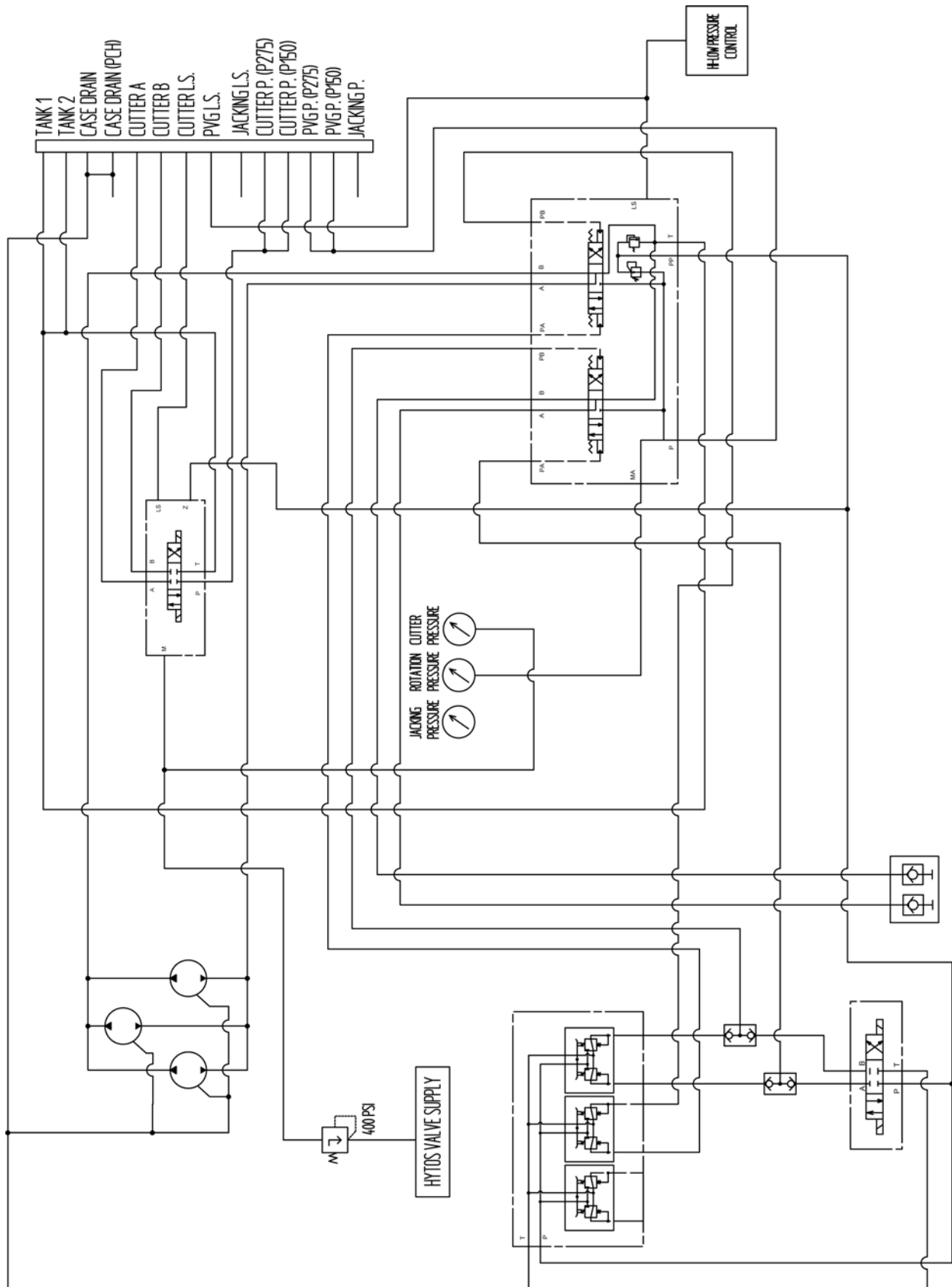

HYDRAULIC SCHEMATIC - GBM 4812A (PART 2 OF 2)

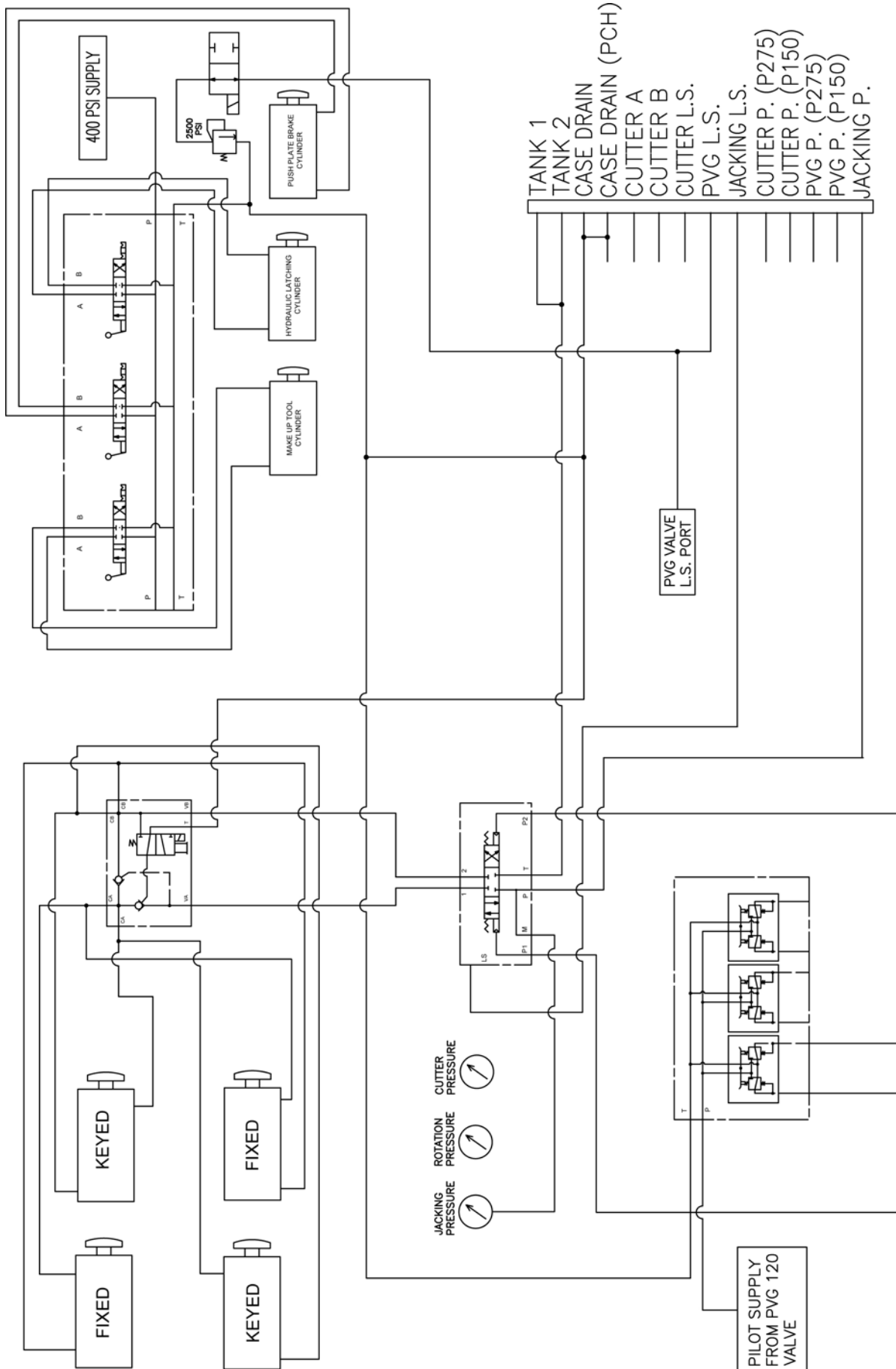

HYDRAULIC SCHEMATIC - POWER PACK P275T

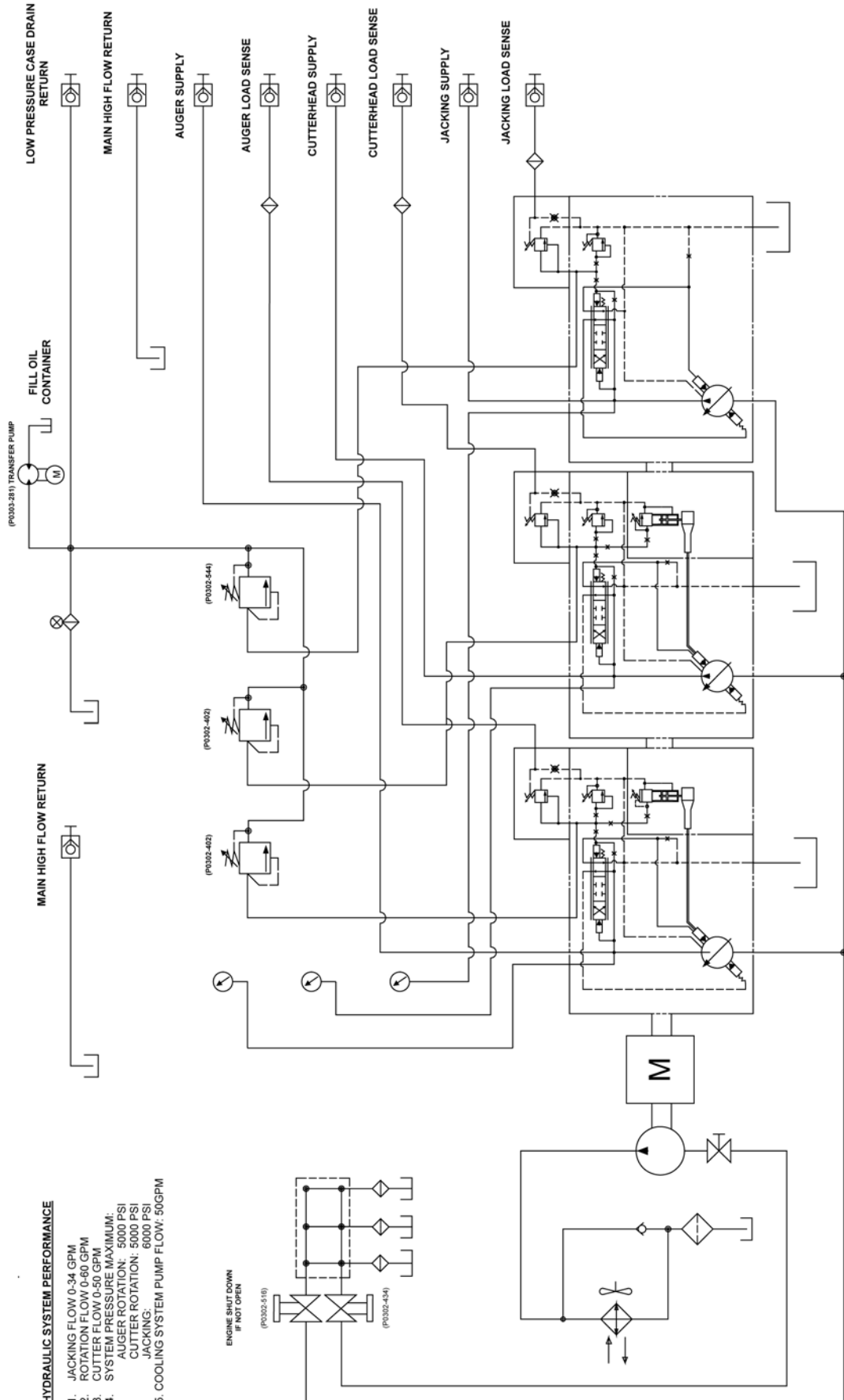

HYDRAULIC SYSTEM PERFORMANCE

1. JACKING FLOW: 0-34 GPM
2. ROTATION FLOW: 0-60 GPM
3. CUTTER FLOW: 0-60 GPM
4. SYSTEM PRESSURE MAXIMUM:
 AUGER ROTATION: 5000 PSI
 CUTTER ROTATION: 5000 PSI
 JACKING: 6000 PSI
5. COOLING SYSTEM PUMP FLOW: 50GPM

HYDRAULIC SCHEMATIC - POWER PACK P150Q

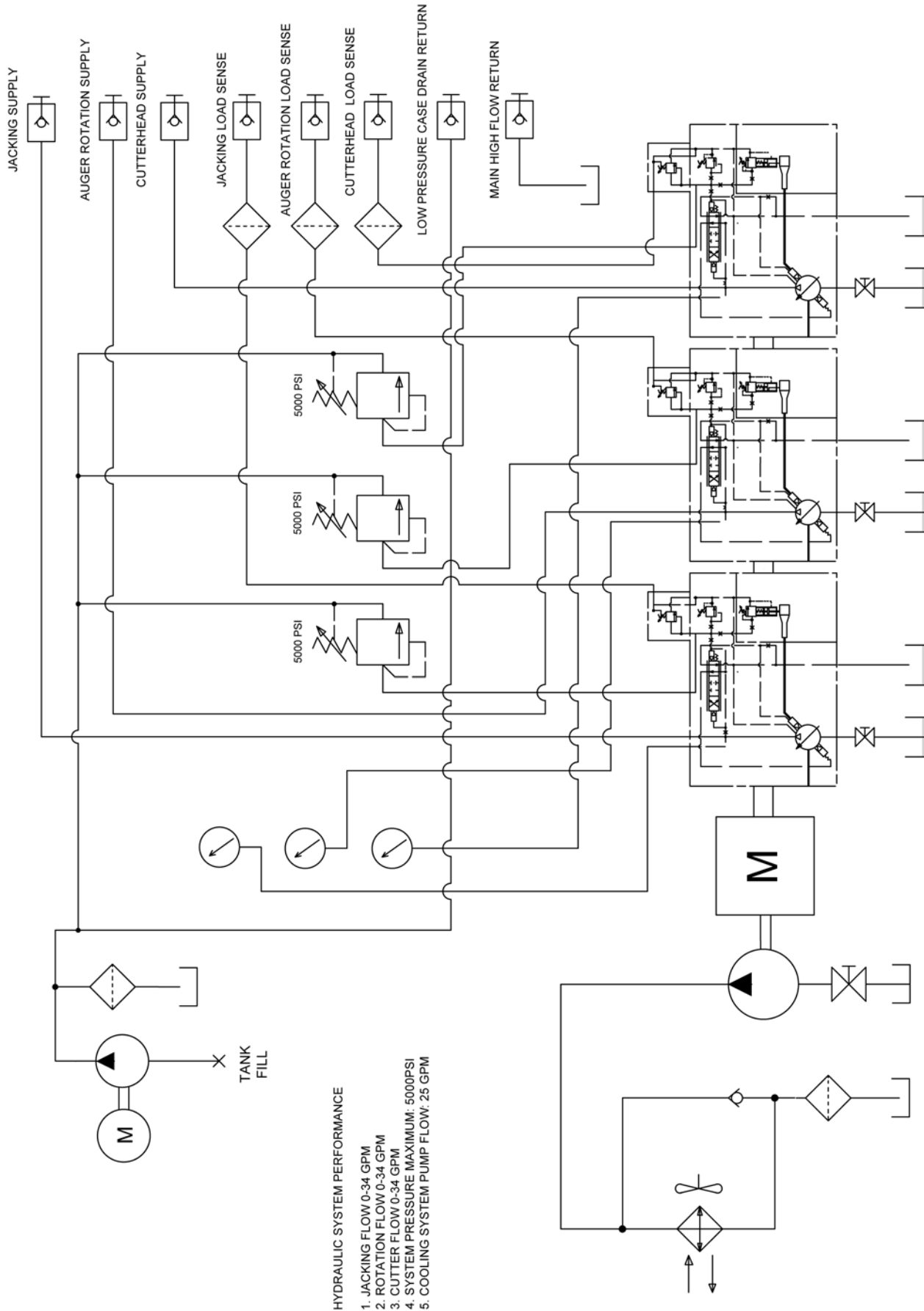

ELECTRICAL SCHEMATIC - GBM 4812A

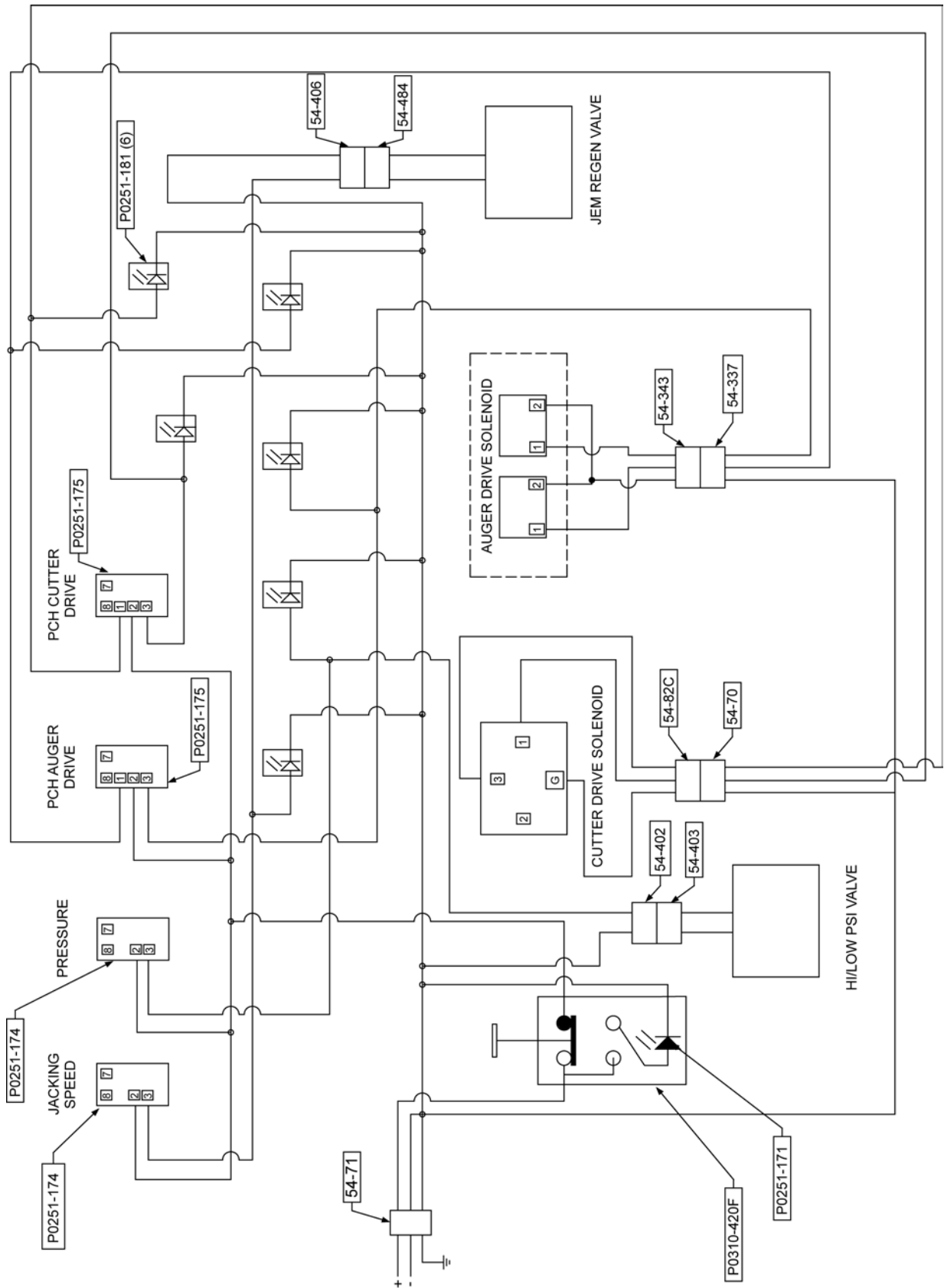

ELECTRICAL SCHEMATIC - POWER PACK P275T

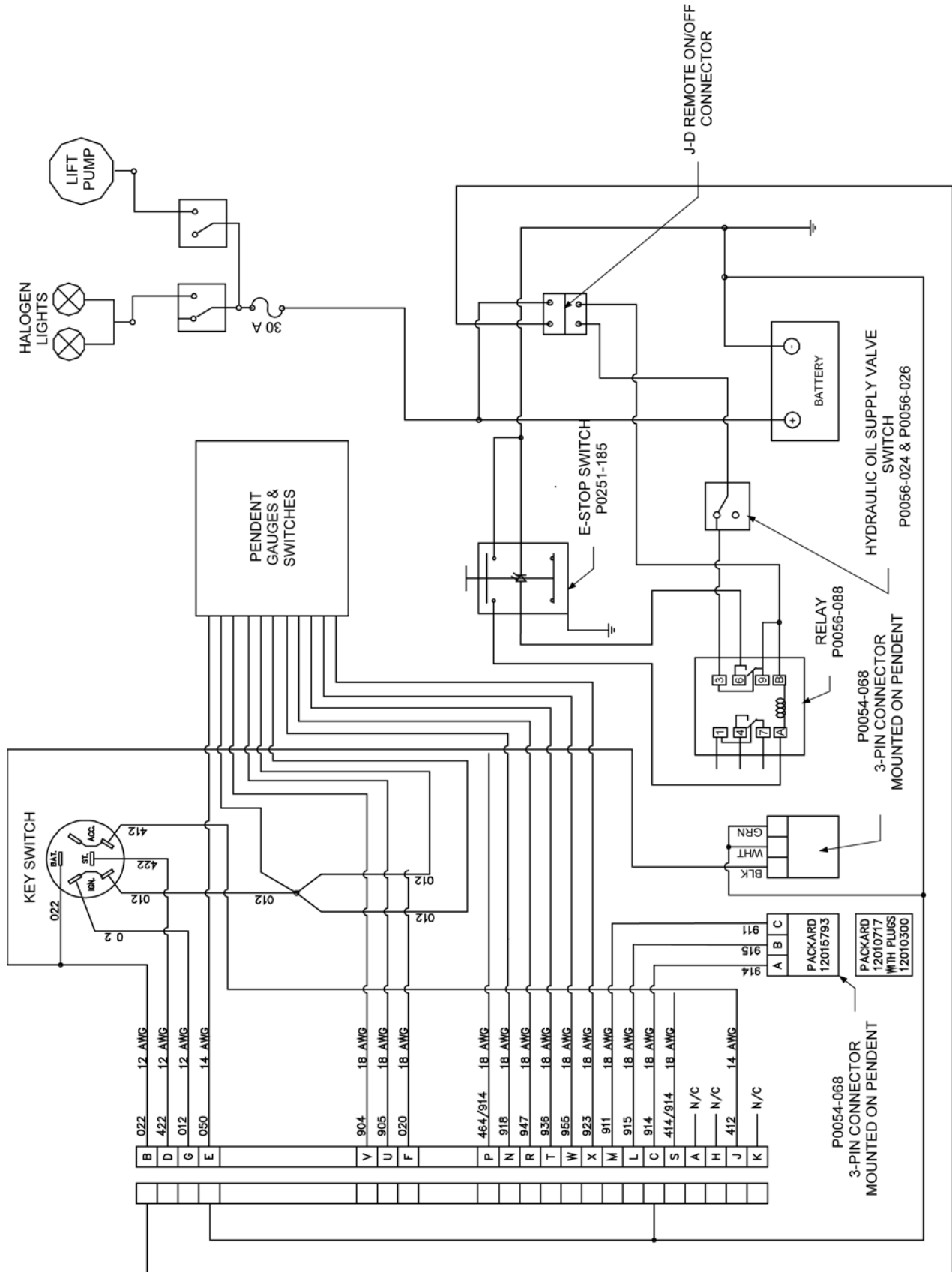

ELECTRICAL SCHEMATIC - POWER PACK P150Q

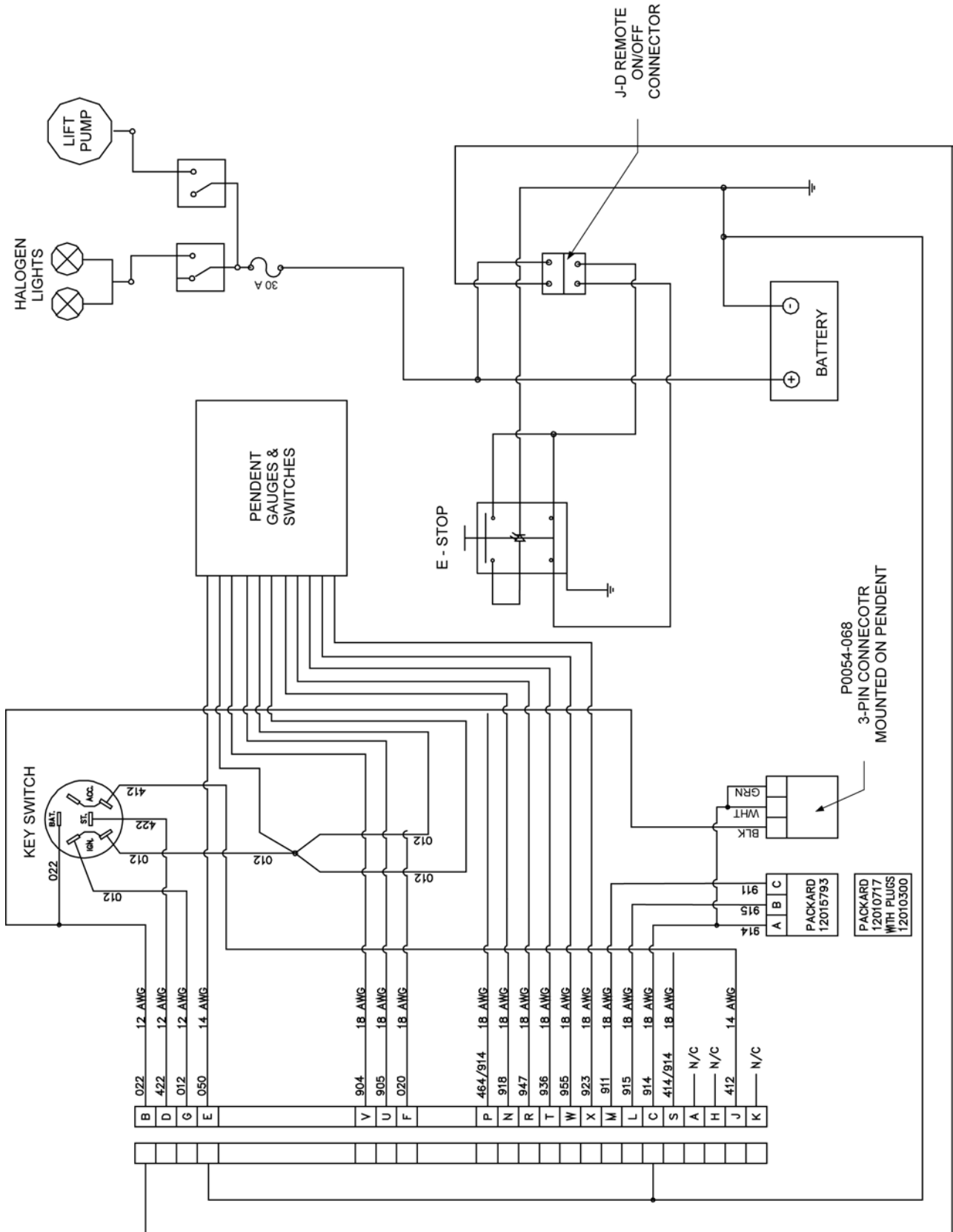

HYDRAULIC SCHEMATIC - PCH 20

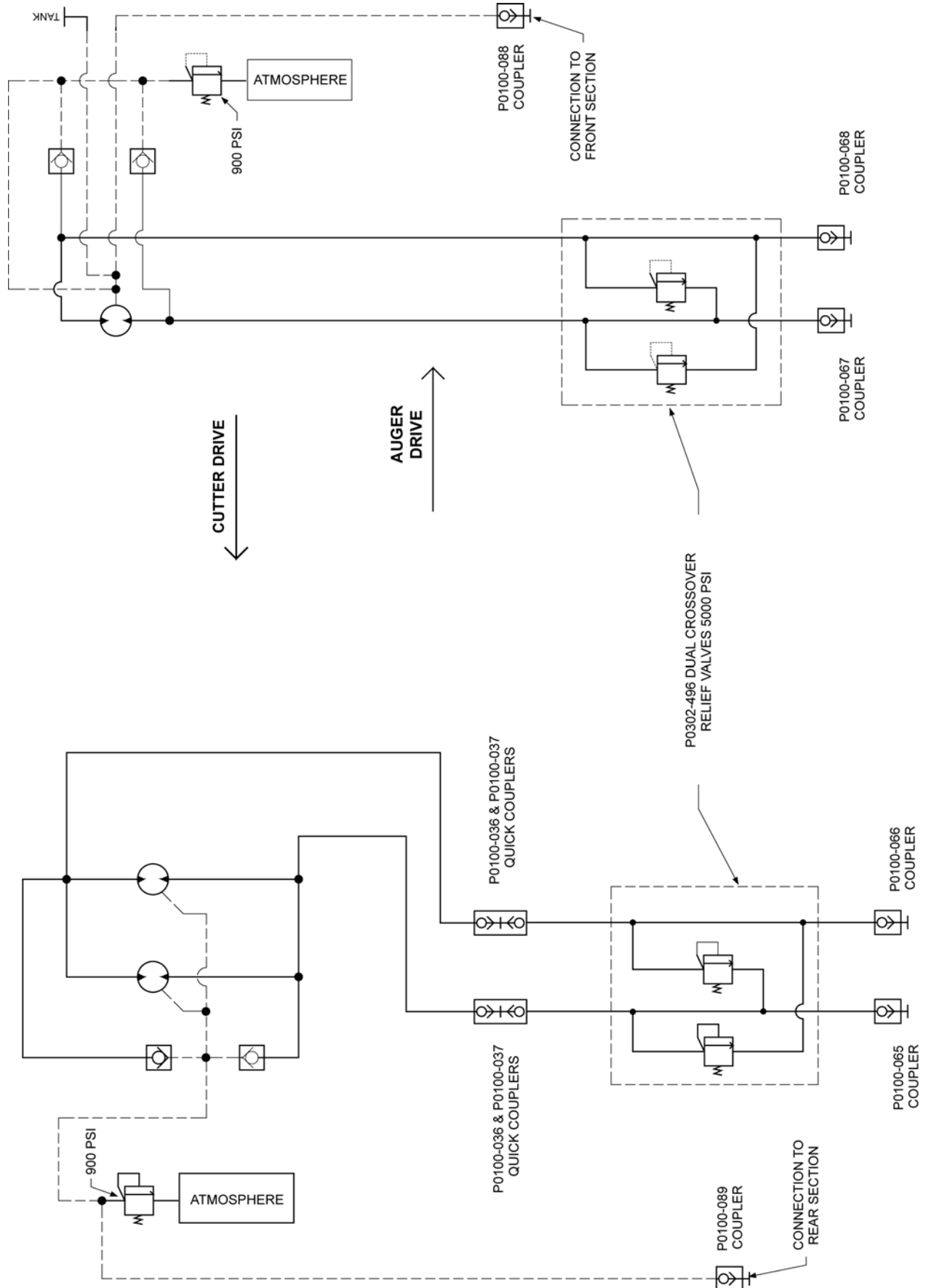

HYDRAULIC SCHEMATIC - PCH 22.5

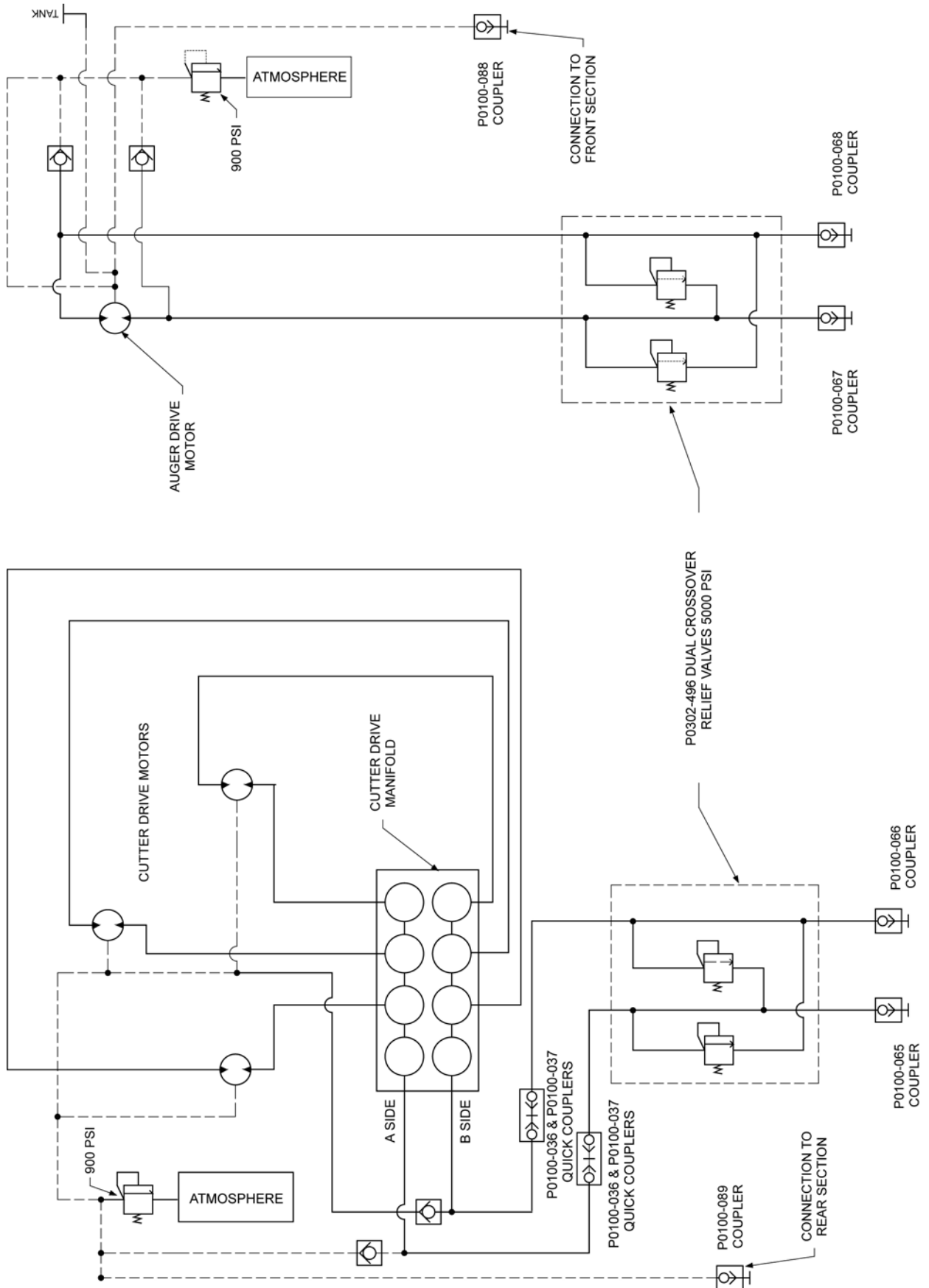

HYDRAULIC SCHEMATIC - PCH 28.5

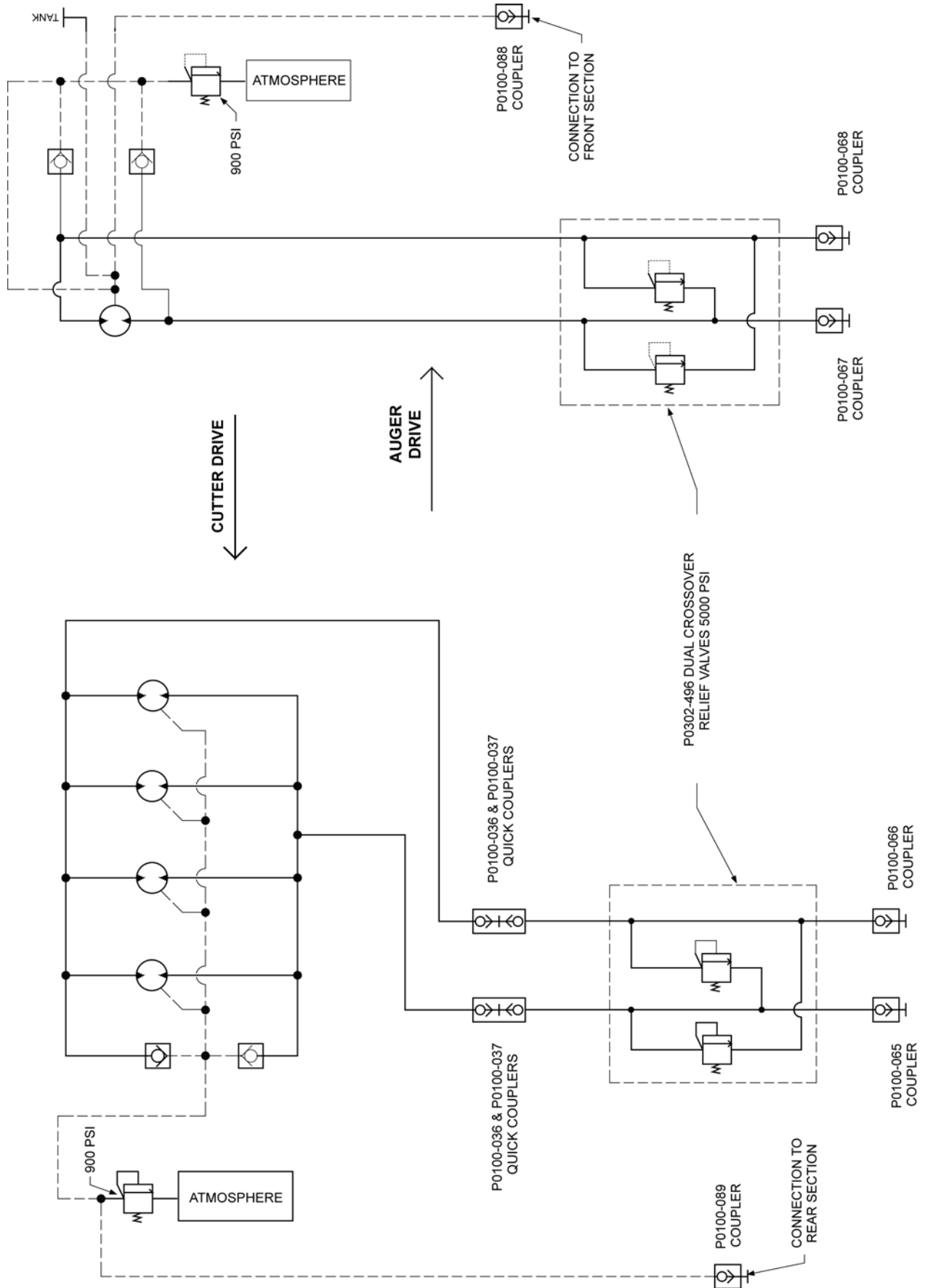

NOTES

Specifications

GBM - 4812A FRAME

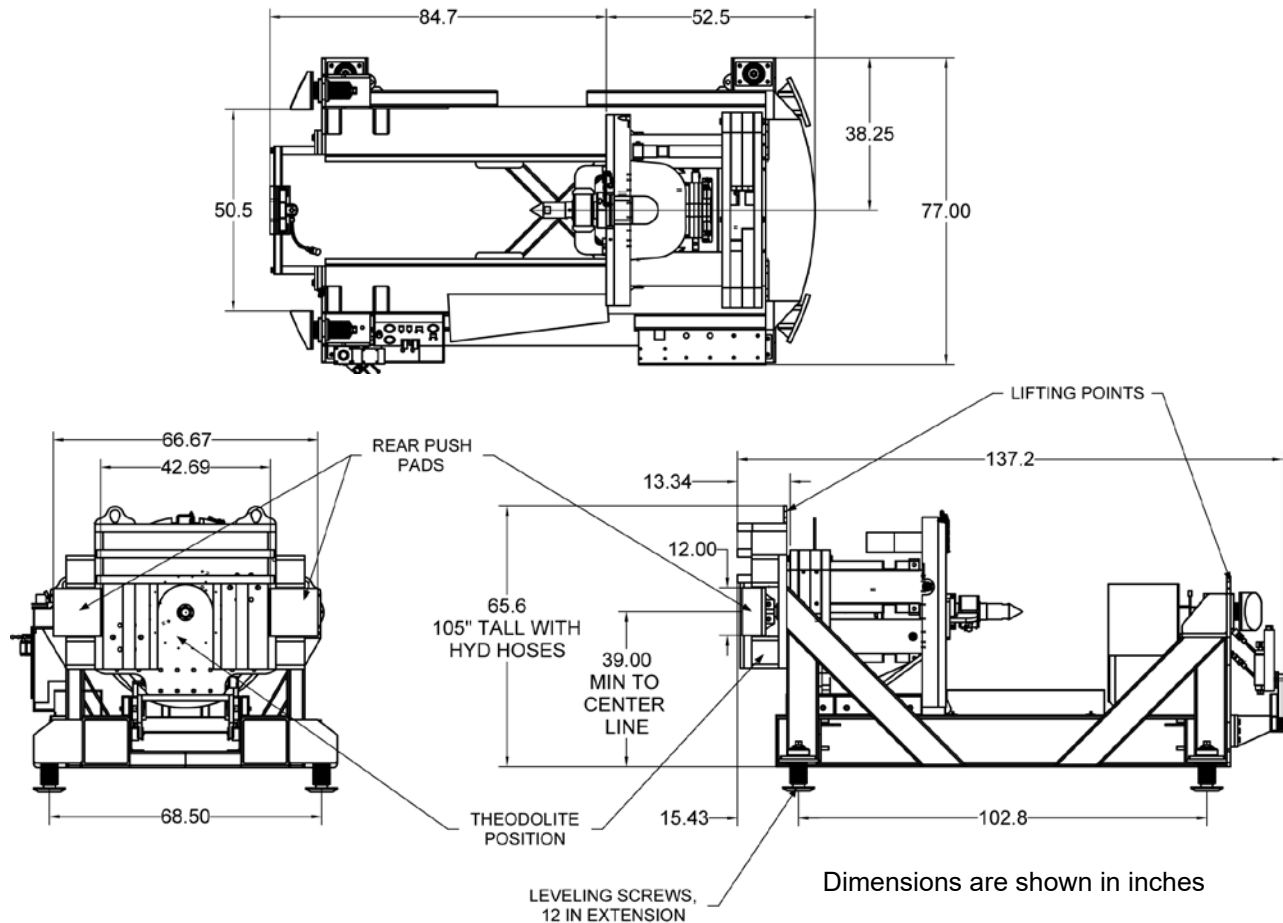

Dimensions

Width	84 in. (2,134 mm)
Length	137 in. (3,480 mm)
Height (top of frame).....	65.6 in. (1,666 mm)
Height (top of hydraulic hoses).....	105 in. (2,667 mm)

Assembly Weight 19,000 lbs. (8,636 kg)

Staging Extension 20 in. (508 mm)

Cylinder Stroke

Each Cylinder	33.5 in. (851 mm)
Total	67 in. (1,702 mm)

Operating Pressure (Maximum)

Jacking	0 to 26 gpm @ 6,000 psi (41.369 MPa)
Rotation	(0 to 34 gpm [P150Q]), (0 to 60 gpm [P275T]) @ 5,000 psi (34.475 MPa)
Cutter Bit Rotation	(0 to 34 gpm [P150Q]), (0 to 50 gpm [P275T]) @ 5,000 psi (34.475 MPa)

Elevation (from shaft floor to drive center) 39 to 51 in. (991 to 1,295 mm)

Operating Grade (Maximum) 10%

Auger Drive

Rotational Torque (low/high)	10,500 ft-lbs./20,000 ft-lbs. (14,238/27,120 N·m)
Gear Box Capacity	8 qt (7.6 L)
Jacking Force	100/200 Ton (91/181 mt)
Pull Back Force	100 Ton (91 mt)

Hydraulic Motor Speed 0 - 38 rpm

GBM - P275T POWER PACK

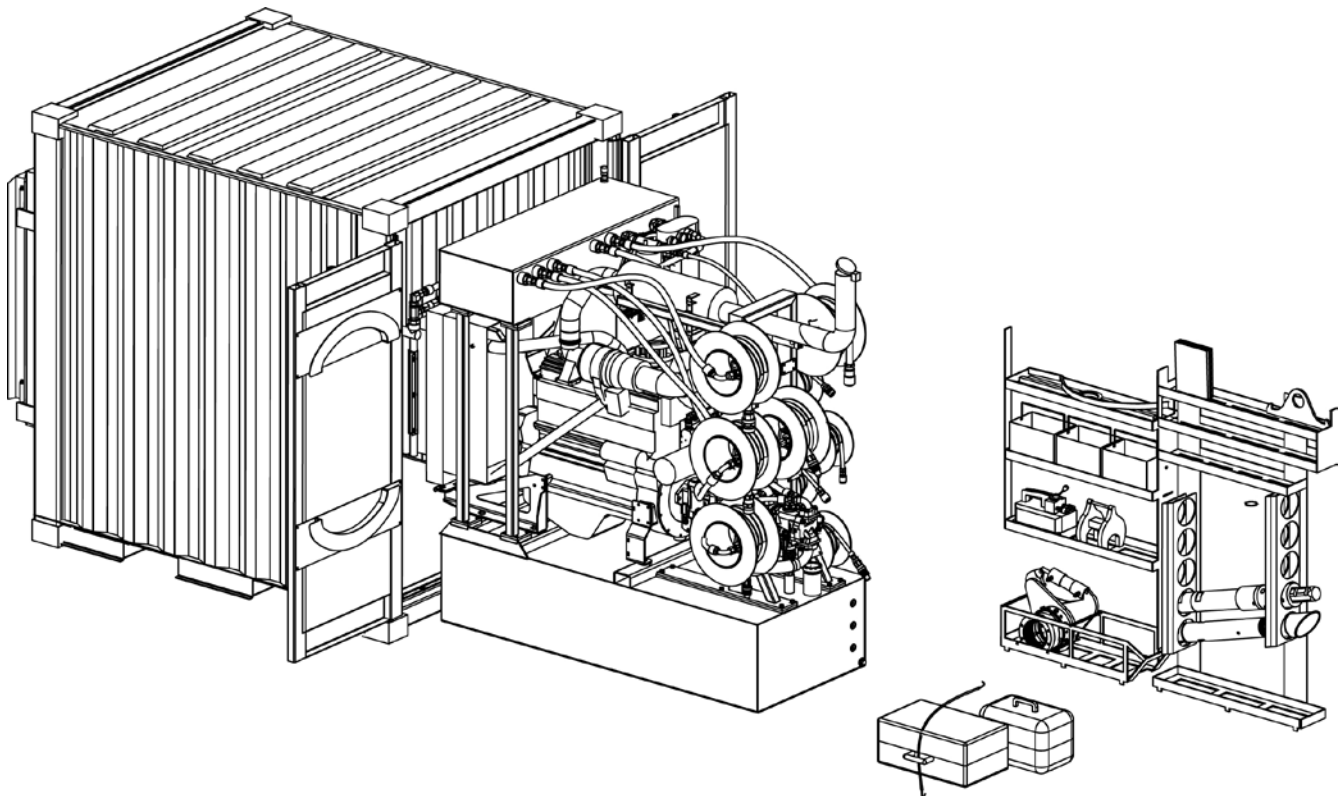

Dimensions

Height	96 in. (2,438 mm)
Width	83.75 in. (2,127 mm)
Length	107 in. (2,731 mm)
Weight	12,500 lbs. (5,670 kg)

Fluid Capacities

Fuel Tank	275 gal (1,041 L)
Hydraulic Reservoir	80 gal (303 L)
Engine Oil	28.5 qt (27 L)
Coolant	12.5 qt (11.8 L)

Power Unit

JD 6068, Six Cylinder Diesel Engine	275 HP (205 kW)
---	-----------------

Pumps

Variable Piston	
Jacking	0 to 26 gpm (0 to 98 L/min)
Rotation: Auger	0 to 60 gpm (0 to 227 L/min)
Rotation: PCH Cutter Bit	0 to 50 gpm (0 to 189 L/min)
Operating Pressure (Maximum)	
Rotation	5,000 psi (34.475 MPa)
Jacking	6,000 psi (41.368 MPa)
Gear Pump (Cooling)	50 gpm (189 L/min)

GBM - P150Q POWER PACK

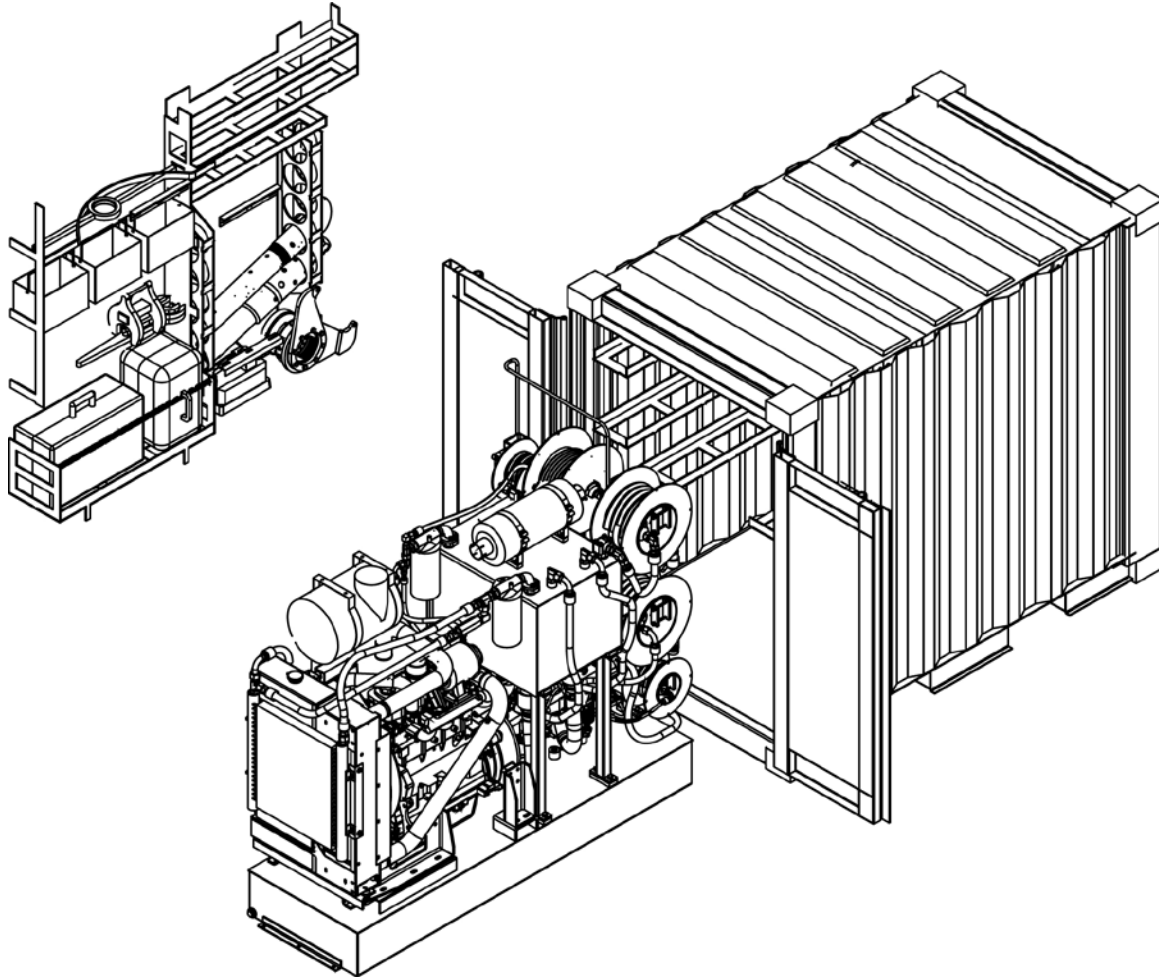

Dimensions

Height	82 in. (2,083 mm)
Width	58 in. (1,473 mm)
Length	96 in. (2,438 mm)
Weight	8,500 lbs. (3,855 kg)

Fluid Capacities

Fuel Tank	100 gal (378 L)
Hydraulic Reservoir	50 gal (189 L)
Engine Oil	21.6 qt (20.5 L)
Coolant	9 qt (8.5 L)

Power Unit

JD 4.5 L 4045 Engine	154 HP (115 kW)
----------------------------	-----------------

Pumps

Variable Piston	
Jacking	0 to 34 gpm (0 to 129 L/min)
Rotation	0 to 34 gpm (0 to 129 L/min)
PCH Cutterbit	0 to 34 gpm (0 to 129 L/min)
Operating Pressure (Maximum)	5,000 psi (34.475 mPa)
Gear Pump (Cooling)	25 gpm (95 L/min)

GUIDANCE SYSTEM

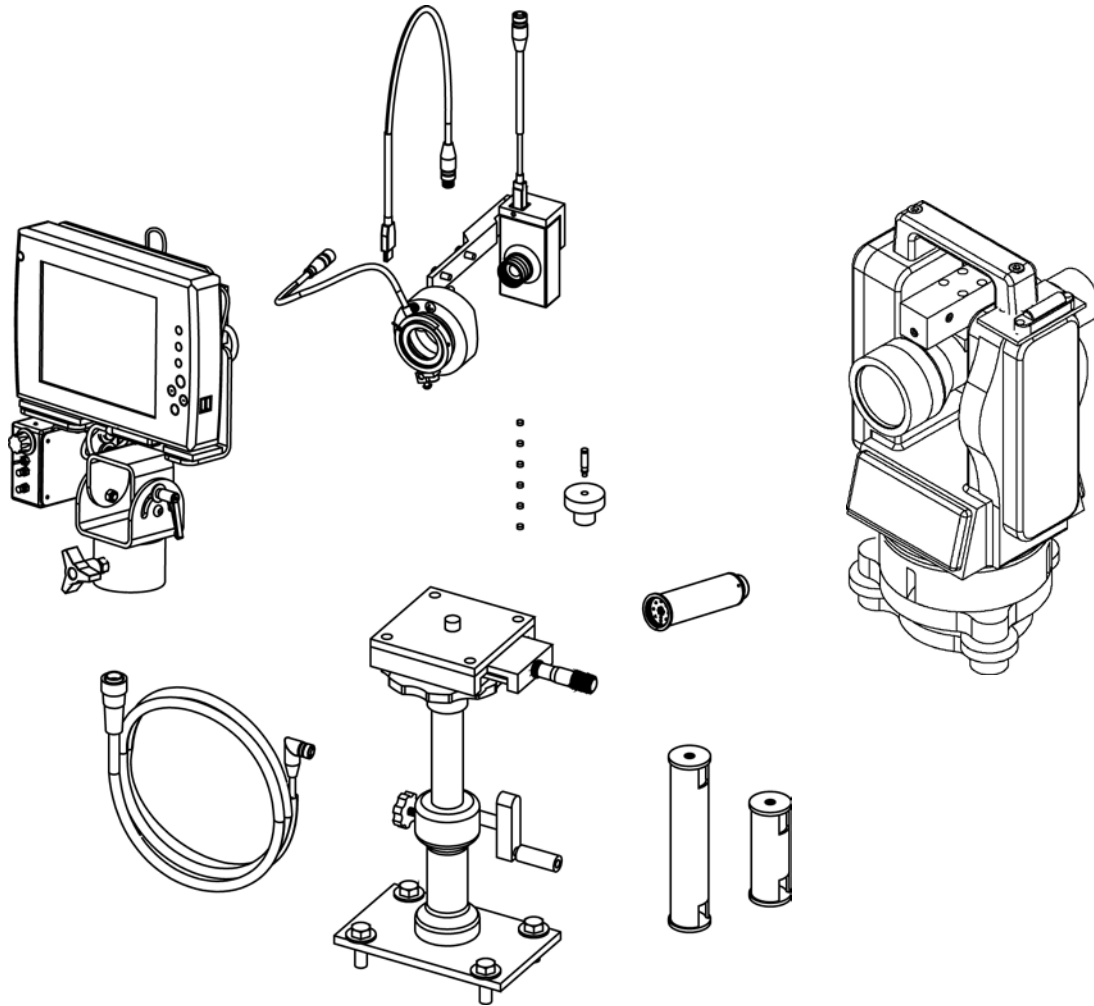

Dimensions (width x length x height)

Theodolite Case

..... 12 x 19.5 x 12 in. (305 x 495 x 305 mm)

Monitor Case

..... 15 x 24 x 10 in. (381 x 610 x 254 mm)

Target Red LED

Rechargeable

Battery Life Up to 6 Days Per Charge

Replaceable (Two 1.5 Volt D Size Alkaline Batteries)

Battery Life Up to 14 Days

Theodolite Accuracy 5 sec (1.5 mgon) DIN

Bore Sight

Laser Visible Red Diode

Minimum Range for Sighting String Lines

..... 30 in. (762 mm)

Operation on/off end cap

Type visible red diode laser

Power Supply (3) 392 button batteries

Construction brass

- The guidance system consists of a theodolite, illuminated target, target charger, tablet assembly, camera, lateral slide assembly, elevator column assembly, counterweight, alignment holder, bore sight laser, and protective cases.
- The theodolite is used to align and maintain line and grade with a designed accuracy of .25 inch up to 300 feet.
- The rechargeable or replaceable, battery powered, illuminated target is positioned in the steering head.
- The video surveillance system consists of a 1.4 mega-pixel camera mounted on the theodolite which transfers digital video of the illuminated target to the monitor.
- The target image is computer enhanced and displayed on the tablet monitor.
- The lateral slide and elevator column adjusts the micro calibration of the horizontal line and vertical grade.
- The theodolite focus is controlled from the remote focus on the docking station.

BREAKOUT TOOL POWER UNIT

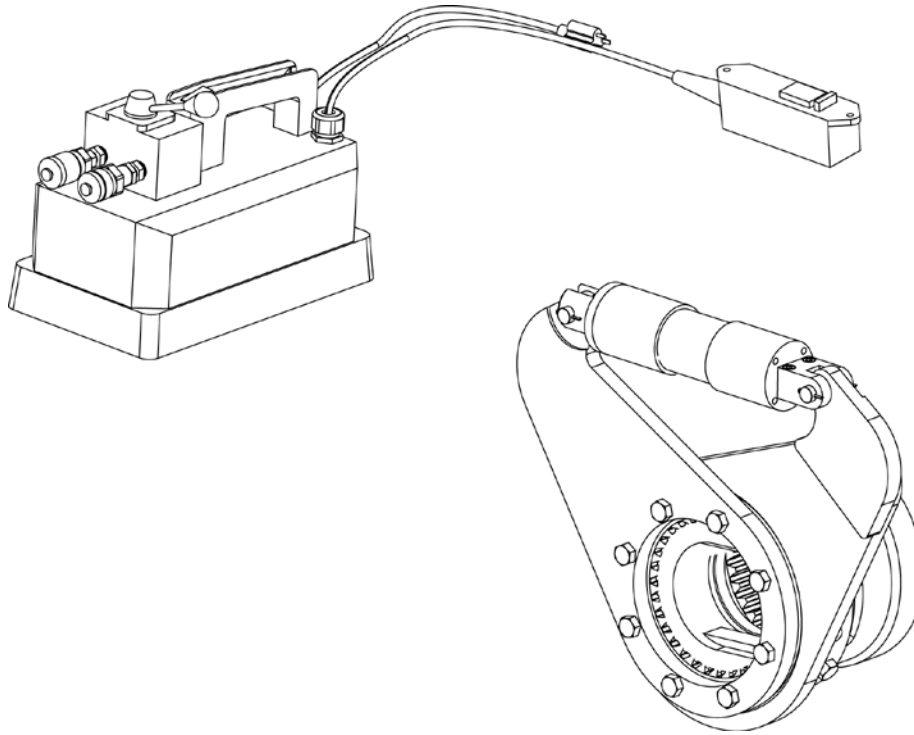

Power Unit

Power Source

60 Hz	110 VAC, 1/4 HP
50 Hz	230VAC, 1/4 HP

Hydraulics (2 Stage Hydraulics)

Stage 1	120 Cu-In/Min. To 400 PSI
Stage 2	10 Cu-In/Min. To 5,000 PSI

Breakout Torque

Maximum Torque	12,193 ft-lbs. @ 5,000 PSI
----------------------	----------------------------

POWERED CUTTER HEAD

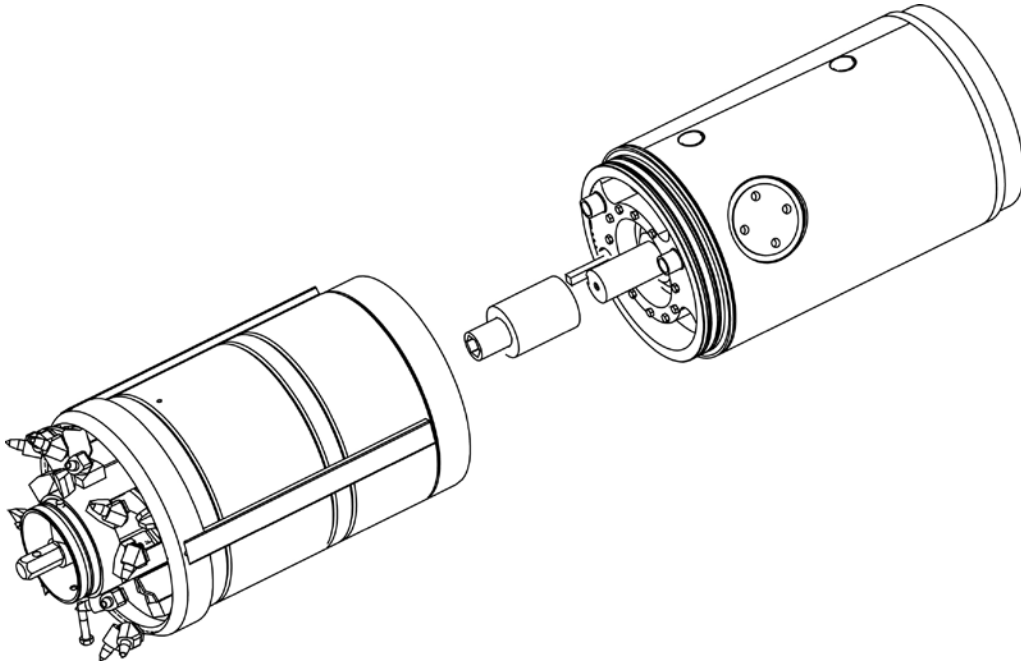

Assembly Length

PCH 20 - 28.5	72 in. (1,829 mm)
PCH 36 - 44	91 in. (2,311 mm)

Front & rear sections MUST be launched separately

Diameter

Powered Cutter Head Body

PCH 20	20 in. (508 mm)
PCH 22.5	22.5 in. (572 mm)
PCH 28.5	28.5 in. (724 mm)
PCH 36	36 in. (914 mm)
PCH 44	44 in. (1,118 mm)
Overcut	1.5 in. (38 mm)

Weight (approximate)

Front Section

PCH 20	1,800 lbs. (816.5 kg)
PCH 22.5	2,000 lbs. (907 kg)
PCH 28.5	3,000 lbs. (1,361 kg)
PCH 36	4,300 lbs. (1,955 kg)
PCH 44	6,500 lbs. (2,955 kg)

Rear Section

PCH 20	900 lbs. (408 kg)
PCH 22.5	1,000 lbs. (454 kg)
PCH 28.5	1,700 lbs. (771 kg)
PCH 36	3,000 lbs. (1,364 kg)
PCH 44	4,500 lbs. (2,045 kg)

Drive System

Auger Drive

Maximum Torque:

PCH 20 - 28.5	10,500 ft-lbs (14,238 N·m)
PCH 36 - 44	20,000 ft-lbs (27,120 N·m)

Maximum Speed:

PCH 20 - 28.5	40 rpm
PCH 36 - 44	38 rpm

Cutterface Power

PCH 20	32 hp (24 kW)
PCH 22.5	48 hp (36 kW)
PCH 28.5	61 hp (45.5 kW)
PCH 36	79 hp (59 kW)
PCH 44	93 hp (69 kW)

Fluid Capacities

(Approximate Values - Check Oil Level- Must be at check plug level)

Front Section - Bearing Cavity

PCH 20	9.5 qt
PCH 22.5	12 qt
PCH 28.5	28 qt
PCH 36	49 qt
PCH 44	83 qt

Rear Section - Auger Drive Gear Box

PCH 20	3 qt
PCH 22.5	3 qt
PCH 28.5	3 qt
PCH 36	8 qt
PCH 44	8 qt

INTEGRAL BEARING SWIVEL CUTTER HEAD

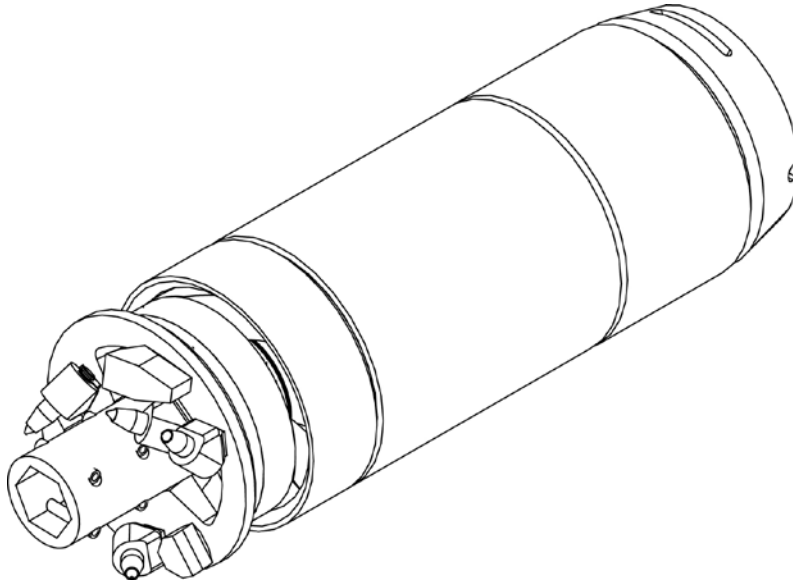

Dimensions (width x length)

11" OD 12.5" OD x 43" (318 x 1,092 mm)
16" OD HD 17.5" OD x 43" (444 x 1,092 mm)

Weight (approx.)

11" OD 700 lbs. (318 kg)
16" OD HD 1,200 lbs. (544 kg)

Thrust Capacity

11" OD
Working Continuous Load 35 Ton
Maximum Intermittent Load 70 Ton

16" OD HD (heavy duty)
Working Continuous Load 50 Ton
Maximum Intermittent Load 100 Ton

HD - Heavy Duty

TORQUE CHART

Use these torque values as a guideline when tightening hardware unless otherwise specified in this manual.

Lubricated Coarse UNC Threads Grade 8 Fasteners			Lubricated Fine UNF Threads Grade 8 Fasteners		
Bolt Size	Torque ft. lbs. (N·m)		Bolt Size	Torque ft. lbs. (N·m)	
1/4 - 20	10	(14)	1/4 - 28	11	(15)
5/16 - 18	20	(27)	5/16 - 24	22	(30)
3/8 - 16	35	(47)	3/8 - 24	39	(53)
7/16 - 14	56	(76)	7/16 - 20	62	(84)
1/2 - 13	85	(115)	1/2 - 20	96	(130)
9/16 - 12	123	(167)	9/16 - 18	137	(186)
5/8 - 11	170	(231)	5/8 - 18	192	(260)
3/4 - 10	301	(408)	3/4 - 16	336	(456)
7/8 - 9	450	(610)	7/8 - 14	500	(678)
1 - 8	680	(922)	1 - 12	740	(1003)
1-1/8 - 7	960	(1302)	1-1/8 - 12	1030	(1397)
1-1/4 - 7	1360	(1844)	1-1/4 - 12	1500	(2034)
1-1/2 - 6	2360	(3200)	1-1/2 - 12	2660	(3607)

UNDERSTANDING GRADE DEGREES VERSUS GRADE PERCENT

The grade degrees and/or grade percent is provided by the project requirements. Below is a way to convert grade degrees to grade percent or vice versa. When entering grade value in degrees or percent of slope in the theodolite, the grade value can be converted from degrees to percent or percent to degrees by simply pressing the % / VA button.

DEGREES GRADE

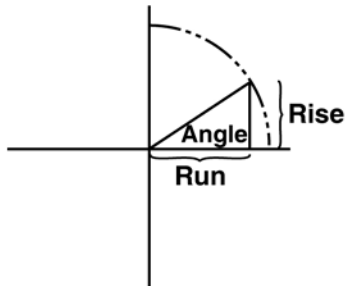
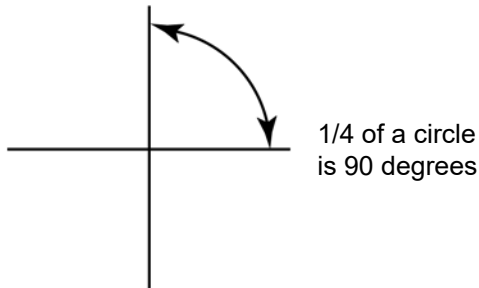
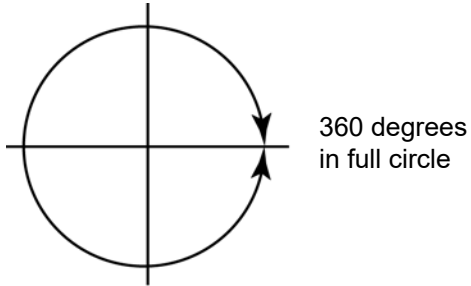

$$\text{tangent (angle)} = \frac{\text{rise}}{\text{run}}$$

$$\text{angle} = \text{arctangent} \left(\frac{\text{rise}}{\text{run}} \right)$$

PERCENT GRADE

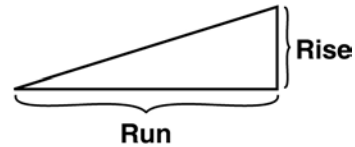

$$\text{percent grade} = \frac{\text{rise}}{\text{run}} \times 100$$

NOTE: Rise and run MUST be in same units, for example, both in feet or both in inches.

Given Percent Grade, calculate Degrees Given Degrees, calculate Percent Grade

$$\text{Degrees} = \text{arctangent} (\text{percent grade} \div 100)$$

$$\text{Percent Grade} = 100 \times \text{tangent} (\text{Degrees})$$

$$45^\circ = 100\% \text{ Grade}$$

$$\text{Degrees decimal} = \text{degrees} + \frac{\text{minutes}}{60} + \frac{\text{seconds}}{60 \times 60}$$

NOTES

Identification Numbers

Model and serial numbers are required when ordering parts or requesting service information. Record your model and serial numbers below.

GBM - 4812A (A)

Model Number _____

Serial Number _____

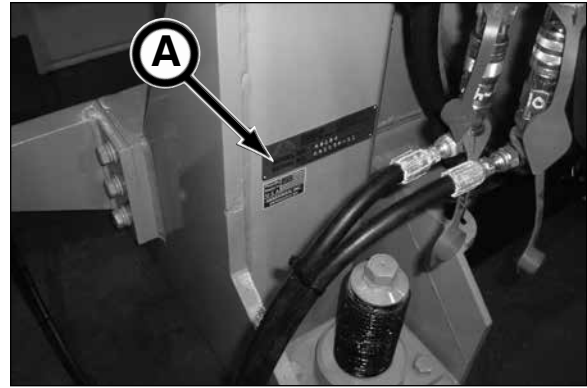

SN 1 - 3

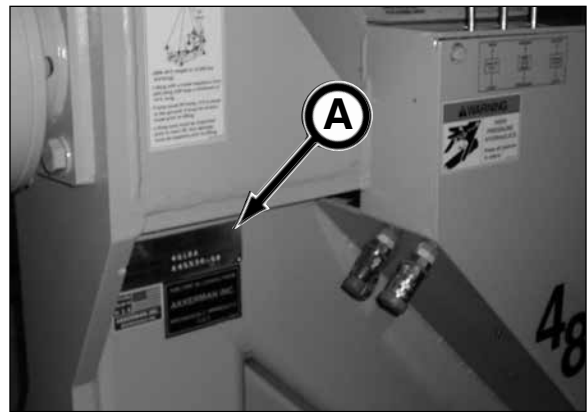

SN 4 & After

POWER PACK (B)

Model Number _____

Serial Number _____

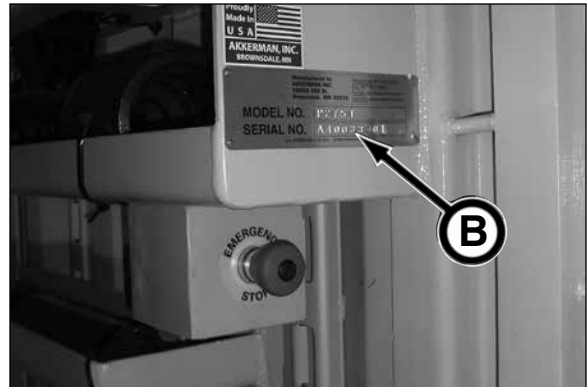

ENGINE (C)

Model Number _____

Serial Number _____



(continued on next page)

TABLET PC (A)*

Model Number _____

Serial Number _____

* Docking Station must be removed to access serial number on tablet PC.
Refer to Docking Station - Removal/Replacement
in section 6, Operation, sub section Guidance System.

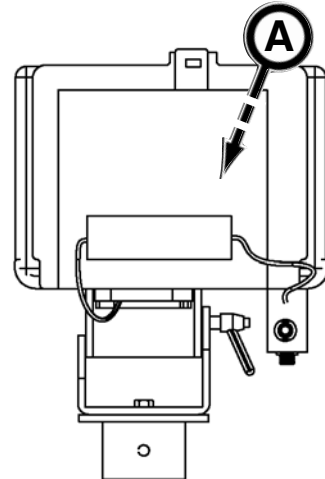

POWERED CUTTER HEAD (B)

Model Number _____

Serial Number _____

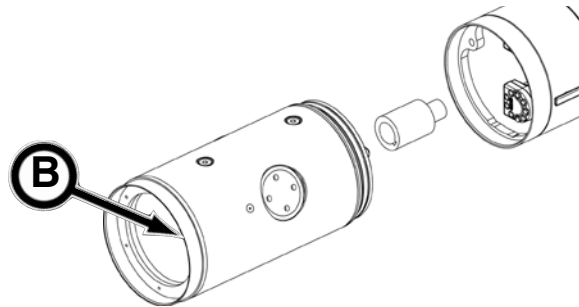

Safety Data Sheets

The Federal Occupational, Safety, and Health Administration (OSHA) Standard 29 CFR 1910.1200, require that specific material safety data sheets (MSDS) be available to employees before operating this equipment. This may include information on substances contained in this equipment such as hydraulic fluid and gear lubricant.

Akkerman Inc. will provide, at no cost, MSDS which apply to its product line. Simply contact your Akkerman Product Support representative for a copy.

To ensure a prompt response to your MSDS request, include your return address (including zip or postal code) and the equipment's model numbers and serial numbers with your request.

NOTES

Warranty

Akkerman Inc. warrants that all equipment manufactured by it be free from defects due to workmanship or material under normal use and service for a period of 90 days. This warranty does not apply to normal wear items such as cutter teeth, filters, etc. Akkerman Inc. does not warrant the fitness of its equipment for a particular purpose or application.

Warranty

NOTES

Index

A

Adapter to steering head,
installing steering head 6-30-1
Adjusting thrust pressure 6-20-7
Alignment, rough center 6-15-3
Assembling the guidance system 6-25-6
Assembly, tablet pc 3-7
Auger & casing, installing safety chain
assembly to 6-35-22
Auger, keep away from 1-7
Auger casings, handling 1-4
Auger casing with reaming head, installing .. 6-35-1
Auger control, PCH 4-2
Auger drive lubricant 8-3

B

Back through launch shaft, pilot tube pull 6-45-1
Baskets, wire casing decals 2-4
Battery safely, maintain 1-2
Bearing cavity lubricant, bearing swivel..... 8-5
Bearing cavity & gear box lubricant, PCH 8-4
Bearing swivel installation 6-35-24
Bearing swivel lubricant 8-5
Bearing swivel maintenance.. 9-3, 9-11, 9-17, 9-60
Brake control, push plate..... 4-3
Breakout tool power unit
lubricant..... 8-3
specifications..... 12-5
Bump speed enable switch..... 4-16

C

Calibration, checking theodolite zero point... 6-25-1
Camera & theodolite 4-7
Camera connections, checking
guidance system 6-25-27
Camera optics 3-13
terminology 3-13
Camera to computer, connecting new 6-25-26
Casing, installing safety chain assembly/casing
auger pin to auger & 6-35-22
Casings, handling auger 1-4
Casing wire baskets decals 2-4
Casing with reaming head, installing auger.. 6-35-1
Cavity & gear box lubricant, PCH bearing 8-4
Chain assembly/casing auger pin to auger
& casing, installing safety 6-35-22
Chart, torque 12-8
Charts, maintenance -
4812A, P275T & P150Q 9-3
PCH 9-64
Checking guidance system camera
connections 6-25-27
Checking theodolite zero point calibration.... 6-25-1
Clean and inspect equipment, regularly 1-4
Clean and organized, keep job site 1-8
Cleaning tablet pc screen 6-25-24

C (continued)

Clothing, wear protective 1-1
Computer, connecting new camera to 6-25-26
Connecting new camera to computer 6-25-26
Container light switch
P275T 4-13
P150Q 4-15
Contents ii
Control,
drive rotation 4-1
hydraulic latching 4-4
make up tool 4-2
panel shutdown 4-6
PCH auger 4-2
PCH rotation 4-6
push plate brake 4-3
control panel shutdown control 4-6
control panel switch, 12v to monitor & 4-16
pendant 4-16
thrust cylinder 4-1
Controls & instruments 4-1
Controls
GBM 4812A 3-3, 3-4
power pack 4-12, 4-14
terminology, tablet pc 3-12
Coolant, engine 8-4
Coolant temperature gauge, engine 4-16
Cooling system 1-7
Cylinder control, thrust 4-1
Cylinder stop, use 1-6, 9-2

D

Data, entering 6-25-22
Data, monitor, entering 4-10
Data sheets, material safety 14-1
Decals
GBM - 4812A frame 2-1
Pilot tube rack 2-5
Power pack 2-2, 2-3
Thrust casing wire baskets 2-4
Decals, safety 2-1
Degrees versus grade percent,
understanding grade 12-9
Diagnostic gauge/hour meter 4-16
Digitizer pen, monitor using 4-9
Digitizer pen, using 6-25-22
Docking station - removal / replacement .. 6-25-24
Drive lubricant, auger 8-3
Drive rotation control 4-1

E

Electrical schematic
GBM 4812A 11-20
P150Q 11-22
P275T 11-21
Emergency stop 4-13, 4-15, 6-20-6

E (continued)

Enable switch, bump speed	4-16
Engine, starting the	6-20-1, 6-20-3
Engine coolant	8-4
temperature gauge	4-16
Engine oil	
pressure gauge	4-16
specifications	8-1, 8-2
Engine stopping the	6-20-6
Engine troubleshooting, power pack	11-2
Entering data, monitor	4-10
Equipment, regularly clean and inspect	1-4
Exposure, avoid laser light	1-8

F

Filter indicators, hydraulic return	4-13, 4-15
Final theodolite setup	6-25-28
Fire prevention	1-6
Frame quick coupler installation	6-15-6
Frame specifications, GBM - 4812A	12-1
Front section, installing	
PCH 20, 22.5 & 28.5	6-35-55
PCH 36 & 44	6-35-78
Fuels & lubricants	8-1
Fuel specifications	8-1

G

Gauge,	
engine coolant temperature	4-16
engine oil pressure	4-16
Gauge/hour meter, diagnostic	4-16
Gauges, hydraulic pressure	4-5
GBM - 4812A	
frame decals	2-1
frame specifications	12-1
controls terminology	3-3, 3-4
jacking frame terminology	3-1, 3-2
GBM - P275T power pack specifications	12-2
GBM	
frame quick coupler installation	6-15-6
pipe installation	6-5-2
pipe installation PCH	6-5-3, 6-5-4
GBM tooling	3-18, 3-20, 3-22
GBM troubleshooting	11-1
Gear box lubricant, PCH bearing cavity &	8-4
General safety	1-1
Grade & line, preliminary theodolite setup for ...	6-25-11
Grade percent, understanding grade degrees vs ..	12-9
Grease	8-3
Guidance system, assembling the	6-25-6
Guidance system camera connections, check ..	6-25-27
Checking theodolite zero point calibration....	6-25-1
Guidance system setup	6-25-1
Guidance system specifications	12-4
Guidance system terminology	3-8
Guidelines, transporting	7-1

H

Hard power down, monitor	4-8
High-low speed select rocker switch	4-16
High pressure hydraulics	1-6
Hour meter, diagnostic gauge/	4-16
Hydraulic latching control	4-4
Hydraulic oil/fluids under pressure	1-2, 9-2
Hydraulic pressure gauges	4-5
Hydraulic return filter indicators	4-13, 4-15
Hydraulic schematic	
GBM 4812A	11-16
P150Q	11-19
P275T	11-18
PCH 20	11-23
PCH 22.5	11-24
PCH 28.5	11-25
Hydraulics, high pressure	1-6

I

Identification numbers	13-1
Indicators, hydraulic return filter	4-13, 4-15
Inspect equipment, regularly clean and	1-4
Inspection, pre-start	5-1
Installation, quick coupler	6-15-6
Installation options & operation guidelines	6-5-1
Installing PCH 20, 22.5 & 28.5 -	
front section	6-35-55
rear section	6-35-68
Installing PCH 36 & 44 -	
front section	6-35-78
rear section	6-35-88
Installing pilot tubes	6-30-1, 6-30-6
Installing PCH 20, 22.5 & 28.5 -	
rear section	6-35-68
Installing product pipe	6-40-1
Installing safety chain assembly/casing auger pin ..	6-35-22
Installing steering head adapter	
to steering head	6-30-1
Installing upsizing tool	6-35-1
Upsizing tool lubrication from	
reception shaft	6-35-20
Using the latching system	6-35-47
Instruments & controls	4-1
Introduction	i

J

Jacking frame, GBM 4812A	3-1, 3-2
Jacking speed	
control / switch	4-7
Jetting & pipe lubrication with PCH	6-35-51

K

Key start switch	4-16
------------------------	------

L

Laser light exposure, avoid	1-8
Latching control, hydraulic	4-4
Latching system, using the	6-35-47
Launch and reception shafts set up	6-10-1
Launch shaft,	
pilot tube pull back through	6-45-1
setting up the GBM in	6-15-1
Light exposure, avoid laser	1-8
Light switch, container	4-13, 4-15
Line & grade, preliminary theodolite	
setup for	6-25-11
Loads, beware of suspended	1-3
Lockout power before servicing	1-2, 9-1
Log of progress	6-30-14
Low-high- speed select rocker switch	4-16
Lubricant,	
auger drive	8-3
breakout tool power unit	8-3
PCH bearing cavity & gear box	8-4
power pack oil reservoir	8-2
Lubricants & fuels	8-1
Lubricants, storing	8-5
Lubricating product pipe	6-35-53
Lubrication from reception shaft, upsizing tool...	6-35-20
Lubrication with PCH, jetting & pipe	6-35-51

M

Maintenance, periodic	9-1
Maintenance, practice safe	1-4
Maintenance chart - 4812A, P275T & P150Q	
after each drive	9-10
after every 2000 feet	9-11
as required	9-12
every 1000 hours of operation	9-8
every 2000 hours of operation	9-9
every 500 hours of operation	9-7
first 100 hours of operation & every	
500 hours thereafter	9-5
monthly or every 250 hours of operation	9-6
Maintenance chart - PCH;	
after each drive	9-65
after every 2000 feet	9-66
prior to each job launch	9-64
Maintenance charts - 4812A & P275T;	
daily or every 10 hours of operation	9-4
prior to each job launch	9-3
Maintenance charts	
4812A, P275T & P150Q	9-3
PCH	9-64
powered cutter head	9-64

M (continued)

Maintenance detail - 4812A, P275T & P150Q	
after each drive	9-59
after every 2000 feet	9-60
as required	9-61
daily or every 10 hours of operation	9-18
every 1000 hours of operation	9-49
every 2000 hours of operation	9-54
every 500 hours of operation	9-38
first 100 hours of operation & every	
500 hours thereafter	9-30
monthly or every 250 hours of operation.....	9-33
prior to each job launch	9-13
Maintenance detail - PCH	
after each drive	9-72
after every 2000 feet	9-76
prior to each job launch	9-67
Make up tool control	4-2
Material safety data sheets	14-1
Meter, diagnostic gauge/hour	4-16
Miscellaneous, operation	6-45-1
Monitor & control panel switch, 12v to	4-16
Monitor, tablet pc	4-8

N

No smoking in tunnel	1-8
Numbers, identification	13-1
Numbers, serial	13-1

O

Oil/fluids under pressure, hydraulic	1-2
Oil pressure gauge, engine	4-16
Oil pump switch	4-13, 4-15
Oil reservoir lubricant, power pack	8-2
Oil specifications, engine	8-1
Operating guidelines	6-5-1
Operation	6-0-1
GBM frame set up in shaft	6-15-1
Installing	
pilot tubes	6-30-1, 6-30-6
product pipe	6-40-1
upsizing tool	6-35-1
Miscellaneous	6-45-1
Operation guidelines & install options	6-5-1
Power pack operation	6-20-1
Shaft set up	6-10-1
Tablet pc start up &	6-25-20
Using the powered cutter head	6-35-51
Operator's manual, read	1-1
Optics terminology, camera	3-13
Organized, keep job site clean and	1-8
Override shutdown switch	4-16

P

P150Q,	
controls	4-14
decals	2-3
schematic, electrical	11-22
schematic, hydraulic	11-19
specifications	12-3
terminology	3-7
P275T,	
controls	4-12
decals	2-2
schematic, electrical	11-21
schematic, hydraulic	11-18
specifications	12-2
terminology	3-6
Panel shutdown control	4-6
Panel switch, 12v to monitor & control	4-16
PC assembly, tablet	3-9, 3-10, 3-11
PC controls terminology, tablet	3-12
PCH,	
jetting & pipe lubrication with	6-35-51
using the	6-35-51
auger control	4-2
PCH 20, 22.5 & 28.5	
front section, installing	6-35-55
rear section, installing	6-35-68
terminology	3-16
PCH 20, hydraulic schematic	11-23
PCH 22.5, hydraulic schematic	11-24
PCH 28.5, hydraulic schematic	11-25
PCH 36 & 44,	
front section, installing	6-35-78
rear section, installing	6-35-88
terminology	3-17
PCH	
bearing cavity & gear box lubricant	8-4
from reception shaft, removing	6-35-101
maintenance charts	9-64
rotation control	4-6
specifications	12-6
troubleshooting	11-7
PC monitor, tablet	4-8
PC troubleshooting, tablet	11-8
Pen, monitor using digitizer	4-9
Pen, using digitizer	6-25-22
Pendant, control	4-16
Percent, understanding grade degrees	
versus grade	12-9
Periodic maintenance	9-1
Personnel away from moving parts, keep	1-3
Pilot tube pull back through launch shaft	6-45-1
Pilot tube rack decals	2-5
Pilot tubes, installing	6-30-1, 6-30-6
Pinch points, avoid	1-5, 9-1
Pipe,	
installing product	6-40-1
lubricating product	6-35-53

P (continued)

Pipe installation,	
GBM 11" to 16" Pipe	6-5-2
PCH	6-5-3, 6-5-4
Pipe lubrication with PCH, jetting &	6-35-51
Plate brake control, push	4-3
Plumb bob, using	1-3
Power before servicing, lockout	1-2, 9-1
Power down, monitor hard	4-8
Powered cutter head	
auger control	4-2
20 - 22.5 - 28.5 terminology	3-16
36 & 44 terminology	3-17
rotation control	4-6
specifications	12-6
Power pack controls	4-12, 4-14
Power pack	
engine troubleshooting	11-2
oil reservoir lubricant	8-2
operation	6-20-1
Power pack,	
electrical schematic	11-21, 11-22
hydraulic schematic	11-18, 11-19
decals	2-2
terminology	3-6
specifications.....	12-2
Power unit	
lubricant, breakout tool	8-3
specifications, breakout tool	12-5
Pre-start inspection	5-1
Preliminary theodolite setup for	
line & grade	6-25-11
Preparing for storage	10-1
Pressure, adjusting thrust	6-20-7
Pressure, hydraulic oil/fluids under	1-2, 9-2
Pressure gauge, engine oil	4-16
Pressure gauges, hydraulic	4-5
Pressure hydraulics, high	1-6
Pressure switch, rotation	4-7
Prevention, fire	1-6
Prior to each job launch	9-3
Product pipe, installing	6-40-1
Product pipe, lubricating	6-35-53
Protective clothing, wear	1-1
Pull back through launch shaft, pilot tube	6-45-1
Pump switch, oil	4-13, 4-15
Push plate brake control	4-3
Q	
Quick coupler installation	6-15-6
R	
Reaming head, installing auger casing with .	6-35-1
Rear section, installing	
PCH 20, 22.5 & 28.5	6-35-68
PCH 36 & 44	6-35-88
Reception & launch shaft set up	6-10-1

R (continued)

Reception shaft,	
removing PCH from	6-35-101
upsizing tool lubrication from	6-35-20
Recycle	1-8
Recycle waste	1-8
Refueling	1-5
Remote focus, tablet pc	3-10, 3-11
Remote focus, using	4-10, 6-25-23
Removing from storage	10-2
Removing PCH from reception shaft	6-35-101
Reservoir lubricant, power pack oil	8-2
Return filter indicators, hydraulic	4-13, 4-15
Rocker switch, low-high speed select	4-16
Rotation control,	
drive	4-1
PCH	4-6
Rotation pressure switch	4-7
Rough center alignment	6-15-3
S	
Safe maintenance, practice	1-4
Safety	1-1
Safety chain assembly/casing auger pin to	
auger & casing, installing	6-35-22
Safety data sheets, material	14-1
Safety decals	2-1
GBM 4812A frame	2-1
Pilot tube rack	2-5
Power pack	2-2, 2-3
Thrust casing wire baskets	2-4
Schematic	
GBM 4812A, electrical	11-20
GBM 4812A, hydraulic	11-16
P150Q, electrical	11-22
P150Q, hydraulic	11-19
P275T, electrical	11-21
P275T, hydraulic	11-18
PCH 20, hydraulic	11-23
PCH 22.5, hydraulic	11-24
PCH 28.5, hydraulic	11-25
Screen, cleaning tablet pc	6-25-24
Select rocker switch, low-high speed	4-16
Select switch, speed	4-16
Serial numbers	13-1
Servicing, lockout power before	1-2, 9-1
Setting up the GBM in launch shaft	6-15-1
Setup,	
final theodolite	6-25-28
guidance system	6-25-1
Set up, shaft	6-10-1
Setup for line & grade, preliminary,	
theodolite	6-25-11
Shaft & tunnel ventilation, test	1-5
Shaft, pilot tube pull back through launch ...	6-45-1
Shaft, removing PCH from reception	6-35-101
Shaft, upsizing tool lubrication from reception..	6-35-20

S (continued)

Shaft set up	6-10-1
Sheets, material safety data	14-1
Shutdown control, panel	4-6
Shutdown switch, override	4-16
Slippery when wet	1-7
Soil Stabilization	6-35-54
Specification	12-1
auger drive lubricant	8-3
bearing swivel	12-7
breakout tool power unit	12-5
breakout tool power unit lubricant	8-3
engine coolant	8-4
engine oil	8-1
fuel	8-1
GBM 4812A frame	12-1
grease	8-3
guidance system	12-4
P150Q power pack	12-2, 12-3
PCH	12-6
PCH bearing cavity & gear box lubricant	8-4
power pack oil reservoir lubricant	8-2
Speed enable switch, bump	4-16
Speed select rocker switch, low-high	4-16
Speed select switch	4-16
Speed switch, jacking	4-7
Stabilization, soil	6-35-54
Starting the engine	6-20-1
Start switch, key	4-16
Start up & operation, tablet pc	6-25-20
Steering head, installing steering head	
adapter to	6-30-1
Steering head adapter to steering head,	
installing	6-30-1
Stop, emergency	4-13, 4-15, 6-20-6
Stop, use cylinder	1-6
Stopping the engine	6-20-6
Storage	10-1
preparing for	10-1
removing from	10-2
Storing lubricants	8-5
Suspended loads, beware of	1-3
Swivel installation, bearing	6-35-24
Swivel lubricant, bearing.....	8-5
Swivel maintenance, bearing..	9-3, 9-11, 9-17, 9-60
Swivel specifications, bearing	12-7
Switch,	
12v to monitor & control panel	4-16
bump speed enable	4-16
container light	4-13, 4-15
emergency stop	4-13, 4-15
jacking speed	4-7
key start	4-16
low-high speed select rocker	4-16
oil pump	4-13, 4-15
override shutdown	4-16
rotation pressure	4-7
speed select	4-16

S (continued)

System, assembling the guidance	6-25-6
System, cooling	1-7
System, using the latching	6-35-47
System camera connections, checking guidance	6-25-27
System setup, guidance	6-25-1
System specifications, guidance	12-4
System terminology, guidance	3-8

T

Tablet pc

assembly	3-9
controls terminology	3-12
monitor	4-8
remote focus kit	3-10
remote focus, without	3-9
remote focus, with	3-11
screen, cleaning	6-25-24
start up & operation	6-25-20
troubleshooting	11-8
Tachometer	4-16
Temperature gauge, engine coolant	4-16
Terminology	3-1
Camera optics	3-13
GBM 4812A controls	3-3, 3-4
GBM 4812A jacking frame	3-1, 3-2
GBM tooling	3-18
Guidance system	3-8
Powered cutter head	3-16, 3-17
Power pack	3-6, 3-7
Theodolite	3-14
Theodolite & camera	4-7
Theodolite remote focus, using	4-10
Theodolite setup, final	6-25-28
Theodolite setup for line & grade, preliminary	6-25-11
Theodolite terminology	3-14
Theodolite zero point calibration, checking ..	6-25-1
Thrust casing wire baskets decals	2-4
Thrust cylinder control	4-1
Thrust pressure, adjusting	6-20-7
Tool, installing upsizing	6-35-1
Tool control, make up	4-2
Tooling, GBM	3-18, 3-20, 3-22
Tool lubrication from reception shaft, upsizing.	6-35-20
Tool power unit lubricant, breakout	8-3
Torque chart	12-8
Transporting	7-1
Transporting guidelines	7-1

T (continued)

Troubleshooting	11-1
GBM	11-1
PCH	11-7
power pack engine	11-2
tablet pc	11-8
Tube pull back through launch shaft, pilot	6-45-1
Tube rack decals, pilot	2-5
Tubes, installing pilot	6-30-1, 6-30-6
Tunnel, no smoking in	1-8
Tunnel ventilation, test shaft &	1-5

U

Unauthorized welding	1-3
Understanding grade degrees versus grade percent	12-9
Unit lubricant, breakout tool power	8-3
Upsizing tool, installing	6-35-1
lubrication from reception shaft	6-35-20
Use jetting & pipe lubrication with PCH	6-35-51
Using digitizer pen	4-9
Using the latching system	6-35-47
Using the powered cutter head	6-35-51

V

Ventilation, test shaft & tunnel	1-5
--	-----

W

Warranty	15-1
Waste, recycle	1-8
Welding, unauthorized	1-3
Wet, slippery when	1-7
Wire baskets casing decals	2-4

Z

Zero point calibration, checking theodolite ...	6-25-1
---	--------

CALIFORNIA

Proposition 65 Warning

Diesel engine exhaust and some of its constituents are known to the State of California to cause cancer, birth defects, and other reproductive harm.