



OPERATION & PARTS MANUAL

Bentonite & Lubrication Pump 1325B/D

Pump S/N: FA48850F

Publication No. 050122A

Rev. No. 170801

© Akkerman Inc. 2017
All Rights Reserved

Akkerman Inc. 58256 266th Street Brownsdale, MN 55918
Phone: 507-567-2261 Fax: 507-567-2605 email: akk@akkerman.com

SERVICE • RELIABILITY • INNOVATION

Introduction

This manual contains important safety, operation, maintenance, and parts information for your Akkerman 1325B/D Bentonite & Lubrication Pump. You must read and understand this manual, the engine operation manual and any additional equipment manuals before you operate and maintain this equipment. Keep this manual with your 1325B/D Bentonite & Lubrication Pump at all times. Additional copies of this manual may be purchased from the Akkerman Aftermarket Support Department, or downloaded from the Akkerman web site at www.akkerman.com.

The contractor is responsible for the overall safety program on the job site. Use this manual as a part of the safety program.

The use of second rate parts could affect the efficient performance of the 1325B/D Bentonite & Lubrication Pump. ALWAYS use genuine Akkerman parts.

Understand safety signal words, DANGER, WARNING, CAUTION, SAFETY INSTRUCTIONS, and NOTICE. When you see these words in this manual or on safety decals mounted on your equipment, follow the safety message to avoid personal injury and/or property damage.

▲ DANGER Indicates an extremely hazardous situation which, if not avoided, WILL result in death or serious injury.

▲ WARNING Indicates a potentially hazardous situation which, if not avoided, COULD result in death or serious injury.

▲ CAUTION Indicates a potentially hazardous situation, which, if not avoided, MAY result in minor or moderate injury. It may also be used to alert against unsafe practices.

SAFETY INSTRUCTIONS Usually consists of individual messages stating procedures or actions that must be followed for the safe operation of a product.

NOTICE Identifies potential property damage and important installation, operator, or maintenance information.



Akkerman 1325B/D Bentonite & Lubrication Pump

The 1325B/D Bentonite & Lubrication Pump is designed for the GBM lubrication system though it can be used in other lubrication applications such as pipe jacking and microtunneling. In the GBM jetting application, the pump system aids the GBM cutting process by lubricating the cutter bits and spoils during excavation. In the GBM lubrication application, the pump system assists with lubricating the pilot tubes, casing and augers and product pipe by reducing friction and easing the jacking process. The unit is capable of displacing a viscosity (Marsh Funnel) as high as 50 seconds.

If you find any errors with this manual or have any suggestions for improvement, please let us know. Email your comments via the Akkerman web site (Contact Us web page), or mail your suggestions to: Akkerman Inc, ATTN: Technical Publications, 58256 266th Street, Brownsdale, MN 55918.

Akkerman Inc. reserves the right to improve its product without notice or obligation.

NOTES

Contents

Safety	1-1	Transporting	7-1
Be Alert For Safety Information	1-1	Transporting Guidelines	7-1
Read Operator's Manual	1-1	Lifting Instructions	7-1
Wear Protective Clothing	1-1		
Fluids Under Pressure	1-2	Fuels & Lubricants	8-1
Beware Of Suspended Loads	1-2	Fuel Specifications	8-1
Using A Pressure Washer Wand	1-2	Engine Oil.....	8-2
Avoid Contact With Mixer Shaft & Propeller...	1-3	Hydraulic Tank Oil	8-2
Maintain Battery Safely	1-3	Engine Coolant	8-3
Refueling	1-3	Storing Lubricants	8-3
Avoid Pinch Points	1-3		
Exposure To Dangerous Chemicals	1-4	Periodic Maintenance	9-1
Pressurized Cooling System	1-4	Fluids Under Pressure	9-1
Beware Of Exhaust Fumes	1-4	Using A Pressure Washer Wand	9-1
Fire Prevention	1-5	Avoid Pinch Points	9-1
Practice Safe Maintenance	1-5	Maintenance Charts	9-2
Slippery When Wet	1-5	Daily Or Every 10 Hours Of Operation	9-2
Unauthorized Welding	1-6	First 50 Hours Of Operation & Every 100 Hours Thereafter	9-3
Regularly Clean & Inspect Equipment	1-6	Weekly Or Every 50 Hours Of Operation ...	9-4
Keep Job Site Clean & Organized	1-6	Every 100 Hours of Operation	9-5
Recycle Waste	1-7	Monthly Or Every 200 Hours Of Operation ...	9-6
		Every 400 Hours of Operation	9-7
Decals	2-1	Every 500 Hours of Operation	9-8
		Every 1000 Hours of Operation	9-9
Terminology	3-1	Every 2000 Hours of Operation	9-9
1325B/D Bentonite & Lubrication Pump	3-1	After Each Drive	9-10
Engine	3-2	Maintenance Instructions	9-11
Pump Shaft Control	3-3	Daily Or Every 10 Hours Of Operation	9-11
		First 50 Hours & Every 100 Hrs Thereafter ..	9-18
Controls & Instruments	4-1	Weekly Or Every 50 Hours Of Operation ..	9-20
Pump/Mixer Selector	4-1	Every 100 Hours of Operation	9-21
Mixer Control	4-1	Monthly Or Every 200 Hours	9-26
In-Tank Agitator	4-1	Every 400 Hours of Operation	9-28
Tank Shut Off Valve	4-2	Every 500 Hours of Operation	9-29
Hydraulic Tank	4-2	Every 1000 Hours of Operation	9-33
Fluid Volume Control	4-2	Every 2000 Hours of Operation	9-35
Pressure Gauge	4-3	After Each Drive	9-36
Engine Fuel Lever	4-3		
Engine Key Switch	4-3	Storage	10-1
Engine System Monitor	4-4	Preparing For Storage	10-1
Engine Throttle	4-4	Removing From Storage	10-2
Pump Shaft Control	4-5		
Engine Fault Condition Icons	4-6	Troubleshooting	11-1
		1325B/D Pump	11-1
Pre-Start Inspection	5-1	Engine Fault Condition Icons	11-2
Operation	6-1	Specifications	12-1
Operating Guidelines	6-1	1325B/D Pump	12-1
Lubrication Guidelines	6-2	Torque Chart	12-2
Setting Up Lubrication Pump	6-3		
Lubrication Circuit Hookup	6-4	Identification Numbers	13-1
Using Shaft Control For Lubrication.....	6-7		
Starting The Engine	6-8	Safety Data Sheets	14-1
Shutting Down The Engine	6-10		
Start Up Procedure	6-11	Warranty	15-1
Daily Shutdown	6-15		
Mixing Tank	6-17	Parts	16-1
Cleaning Tank	6-18	Introduction	16-2
Cold Weather Operation	6-21	Decals	16-4
Cold Weather Protection		Parts	16-10 - 16-18
Draining System	6-22		
Using RV Anti-Freeze.....	6-24	Alphabetical Index	17-1
		Numerical Index	18-1

NOTES

Safety

BE ALERT FOR SAFETY INFORMATION

When you see this safety alert symbol on your equipment or in this manual, be alert to the possibility of personal injury or property damage.

Read all safety information.

Keep safety decals clean and in good condition.
Replace missing or damaged safety decals.



**ATTENTION!
BECOME ALERT!
YOUR SAFETY IS INVOLVED!**

READ OPERATOR'S MANUAL

⚠ WARNING Unsafe operation or maintenance can cause severe injury or death.

Read and understand the Operator's Manual before operating or servicing this equipment.

Any unauthorized modifications will void the warranty.

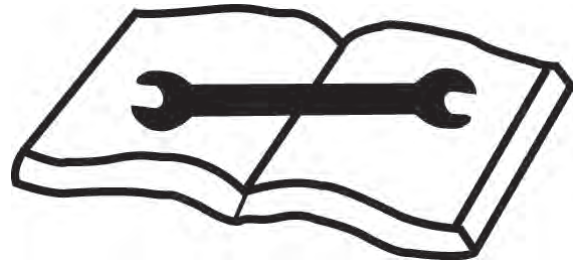

WEAR PROTECTIVE CLOTHING

Wear OSHA approved personal protective equipment (PPE), such as hard hat, gloves, safety goggles, earmuffs or ear plugs, face shield, and steel-toed boots, when operating and servicing this equipment.

Wear reasonably close fitting clothing and remove jewelry before working on or near this equipment. This will help prevent the danger of catching them in moving parts or controls.



FLUIDS UNDER PRESSURE

⚠ WARNING Escaping fluids under pressure can penetrate your skin causing serious injury.

Release all pressure before performing maintenance or repairs. Never weld near pressurized fluid lines.

DO NOT use your hands to check for leaks. When searching for leaks, use a piece of wood or cardboard.

Contact medical help immediately if any fluid is injected into your skin. A serious infection or reaction can emerge without proper medical treatment.



BEWARE OF SUSPENDED LOADS

⚠ WARNING Suspended loads may fall and cause severe personal injury or death.

If a hydraulic hose, chain, or cable from the boom of a crane or excavator breaks, the boom and/or load can fall instantly.

Do not enter area under or around a load.



USING A PRESSURE WASHER WAND

⚠ WARNING Using the lubrication pump with a pressure washer wand can generate enough fluid pressure and velocity to penetrate skin resulting in serious personal injury.

Contact medical help immediately if fluid is injected into your skin. A serious infection or reaction can emerge without proper medical treatment.

NEVER point the wand towards a person or animal.

Be sure to release pressure after use and before performing maintenance to prevent accidental fluid injection.

Wear safety glasses and gloves, and depending on the wand use, a particle mask may be necessary.



AVOID CONTACT WITH MIXER SHAFT & PROPELLER

⚠ WARNING Contacting shaft or propeller may cause serious injury.

Keep ALL parts of body and foreign objects from coming in contact with mixer shaft or propeller during operation.



MAINTAIN BATTERY SAFELY

⚠ WARNING Batteries produce explosive gases.

Wear eye protection and protective clothing during battery service.

Keep sparks, flames, and cigarettes away from batteries.

Contact with battery acid can cause severe burns. Flush immediately and thoroughly with clean water. Get medical attention immediately.

Charge a battery only in a well-ventilated area.

Never charge a frozen battery.



REFUELING

⚠ WARNING Fires and explosions can cause serious injury or death.

Handle fuel with care. It is highly flammable.

DO NOT refuel while smoking or when near open flame or sparks.

Always stop engine before refueling.



AVOID PINCH POINTS

⚠ WARNING Moving parts or the mishandling of parts can cause severe personal injury.

Keep hands away from moving parts.

Watch your fingers, hands, and legs while equipment is in operation.

Handle parts carefully to avoid crushing and pinch point hazards.



EXPOSURE TO DANGEROUS CHEMICALS

⚠ WARNING Exposure to chemicals may cause serious injury or death.

BEFORE mixing chemicals or other agents in the water tank, be sure the area is well ventilated and other personnel removed from the area.

Use proper personal protective equipment (PPE) per the chemical manufacturer's instructions.

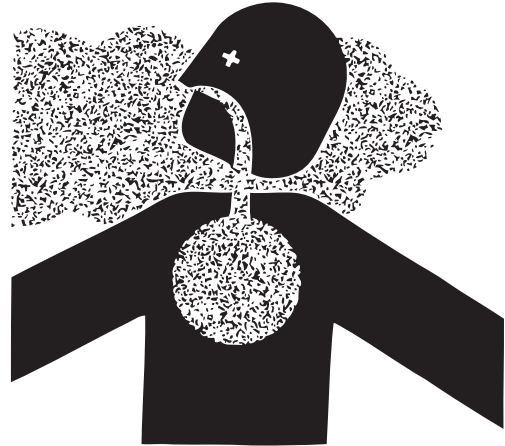

PRESSURIZED COOLING SYSTEM

⚠ WARNING Cooling system under pressure. Explosive release of HOT engine coolant can cause severe burns. SLOWLY remove the radiator cap ONLY if the engine is cool.



BEWARE OF EXHAUST FUMES

⚠ WARNING Exposure to engine exhaust fumes can cause severe injury or death. Always work in a properly ventilated area.

If it is necessary to run an engine in an enclosed area, use the proper equipment to safely remove the exhaust fumes from the working area.



FIRE PREVENTION

⚠ CAUTION Fires can cause injury or property damage.

Keep equipment clean. Remove all debris from equipment.

Have a fire extinguisher available at all times. Keep the fire extinguisher fully charged.



PRACTICE SAFE MAINTENANCE

⚠ WARNING Unexpected movement may cause serious personal injury.

Shutdown engine before performing any maintenance, adjustments, or removing obstructions.

Only trained and qualified personnel should perform any maintenance or repairs.

Keep the area around the equipment clean and dry when performing maintenance.

Do not service the machine while it is in operation.

Replace worn or damaged parts. Remove grease, oil, or debris buildup.



SLIPPERY WHEN WET

⚠ WARNING Slips and falls can cause serious personal injury.

Ensure firm footing in wet or slippery conditions.

Replace skid-resistant material if it is damaged or missing to prevent slips and falls.

Remove any buildup of grease, oil, or debris.



UNAUTHORIZED WELDING

⚠ WARNING Unauthorized welding can cause structural failure resulting in possible injury or death.

Do not weld on any structural member. Unauthorized welding or repair will void the warranty.

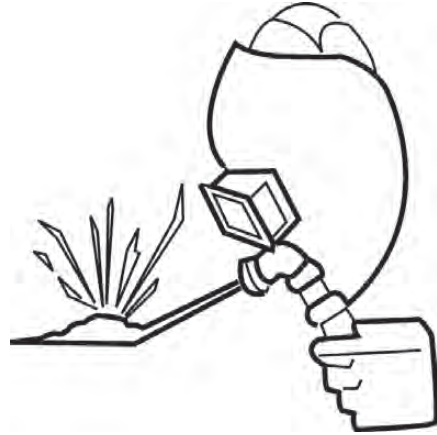

REGULARLY CLEAN AND INSPECT EQUIPMENT

Remove any grease, oil, or debris buildup to avoid potential injury or equipment damage.

Inspect equipment for damage. If damaged, repair or replace immediately.

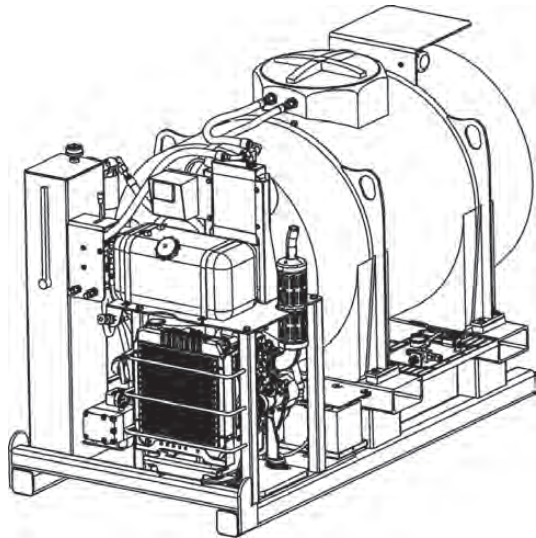

KEEP JOB SITE CLEAN AND ORGANIZED

⚠ WARNING Tripping can cause serious personal injury.

Be sure to keep job site clean and organized.



RECYCLE WASTE

Follow local, state, federal, and international regulations when recycling or disposing of waste. Waste includes fluids/oil, fuel, filters, coolant, and batteries.

Use leakproof containers when draining fluids/oil. Do not pour waste on the ground, down a drain, or into any water source.

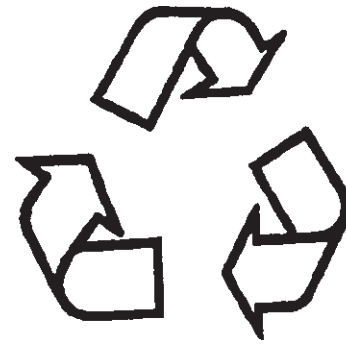

NOTES

Decals

Keep all decals clean and readable. Use soft cloth, water, and a mild soap to clean the decals if they are too dirty to read. DO NOT clean decals with solvent. Solvent can damage them. Replace safety decals immediately if they are damaged, missing, or hard to read.

Serious injury or property damage can occur if safety instructions are not followed. Contact your Akkerman Aftermarket Support representative for free replacement safety decals.

If a part is replaced that has a decal on it, apply a new decal to the replacement part. Before applying a new decal, be sure the surface is clean and dry.

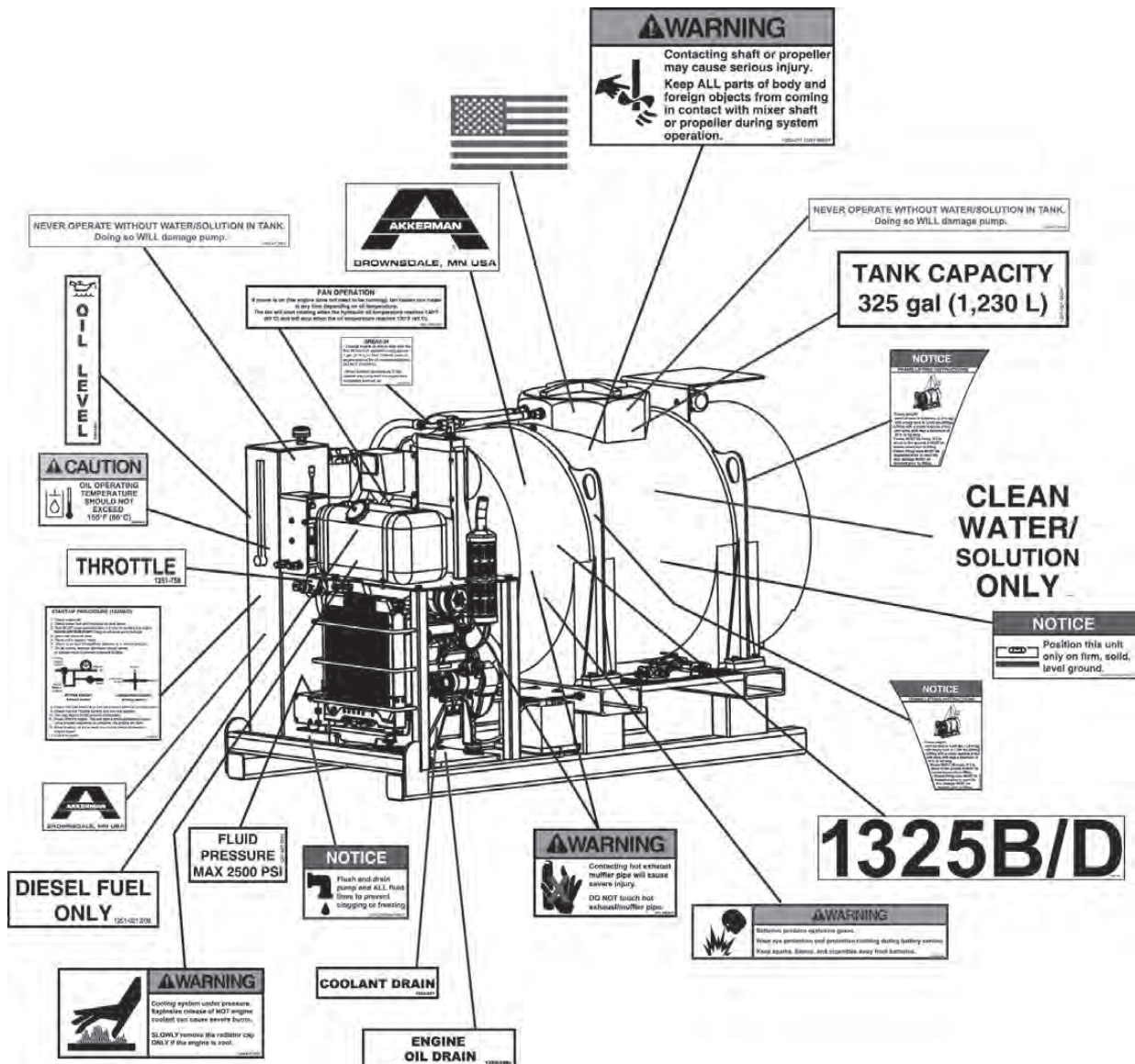

NOTES

Terminology

1325B/D BENTONITE & LUBRICATION PUMP

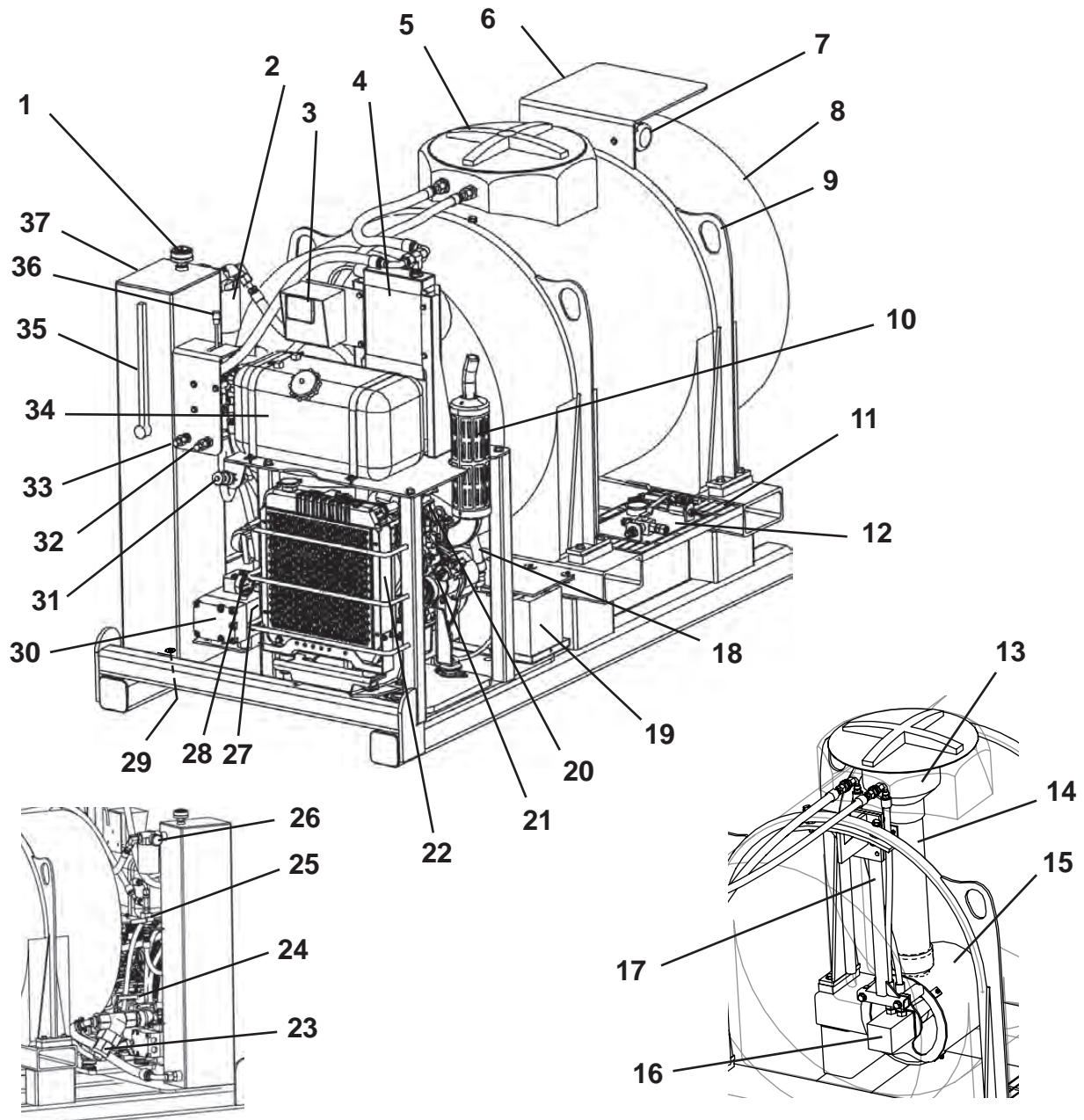

- | | | |
|---|--------------------------------|---|
| 1. Oil Fill Cap & Tank Breather | 13. Removable Reducer Coupling | 26. Hydraulic Filter Indicator |
| 2. Hydraulic Return Filter | 14. Mix Tube | 27. Engine Coolant Fill Reservoir |
| 3. Engine System Monitor | 15. Agitator Chamber | 28. Piston Pump Fluid Pressure Gauge |
| 4. Hydraulic Oil Cooler | 16. Mixer Motor With Propeller | 29. Hydraulic Tank Drain Plug |
| 5. Tank Lid | 17. Mixer/Agitator Mount | 30. Piston Pump 10 GPM |
| 6. Shelf | 18. Hydraulic Pump | 31. Throttle |
| 7. Document Tube | 19. Battery | 32. Return Connection |
| 8. Tank 325 gal. (1,230 L) | 20. Engine Air Cleaner | 33. Pressure Connection |
| 9. Lift Eye | 21. Diesel Engine, 20.7 HP | 34. Diesel Fuel Tank 8 Gal. (30 L) |
| 10. Muffler | 22. Radiator | 35. Hydraulic Oil Level & Temperature Gauge |
| 11. Step | 23. Strainer & Element | 36. Mixer/Pump Selector |
| 12. Pump Shaft Control (shown in shipping position) | 24. Tank Shut Off Valve | 37. Hydraulic Tank 15 Gal. (57 L) |
| | 25. Mixer Control | |

ENGINE

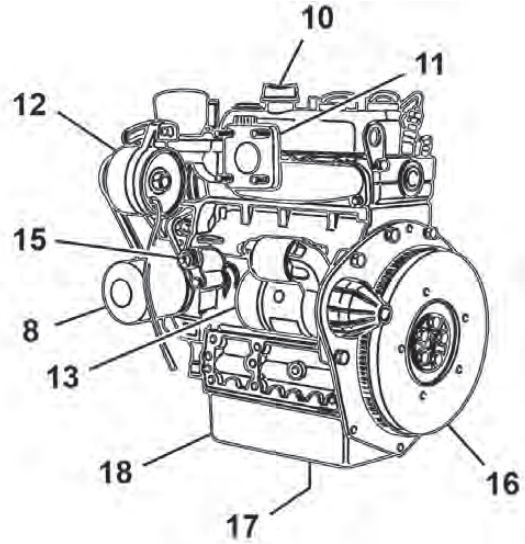
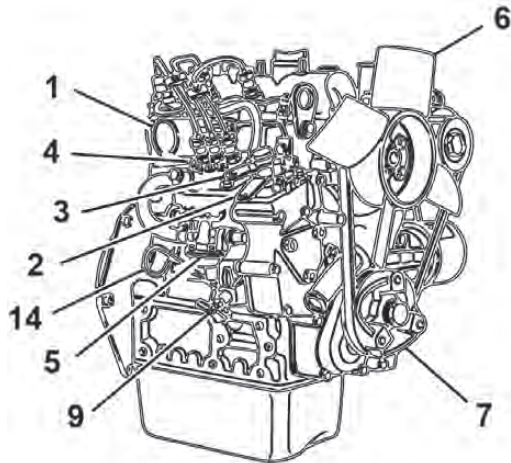

1. Intake Manifold
2. Speed Control Lever
3. Engine Stop Lever
4. Injection Pump
5. Fuel Feed Pump
6. Cooling Fan
7. Fan Drive Pulley
8. Oil Filter Cartridge
9. Water Drain Cock
10. Oil Filler Plug

11. Exhaust Manifold
12. Alternator
13. Starter
14. Oil Dipstick
15. Oil Pressure Switch
16. Flywheel
17. Oil Drain Plug
18. Oil Pan

PUMP SHAFT CONTROL

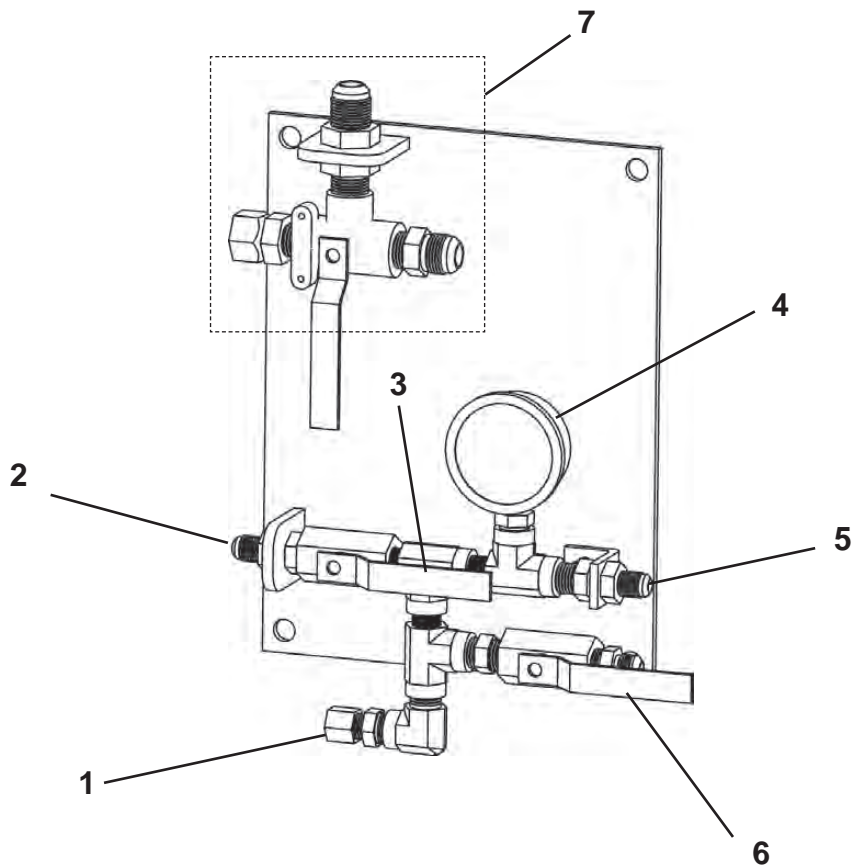

- 1. Washer Wand or Auxiliary Jetting Pressure OUT
- 2. Tooling Pressure OUT
- 3. Pressure Shutoff Valve

- 4. Pressure Gauge 2500 psi Max.
- 5. Pressure IN
- 6. Return Shutoff Valve
- 7. Circuit Control*

* Not used with 1325B; auxiliary lubrication pump required.

NOTES

Controls & Instruments

PUMP/MIXER SELECTOR

The Pump/Mixer Selector (A) is used to regulate the fluid for engine startup, tank recirculation, solution mixing and tooling lubrication by controlling the fluid pump and the in-tank agitator (mixer) functions as follows:

Pump & Mixer	- Forward Position
Neutral	- Middle Position
Mixer Only*	- Back Position

Before starting pump engine, there must be enough water/solution in the tank to cover inlet and the pump/mixer selector MUST be in the neutral position.

* The Mixer Control must be at the ON position.

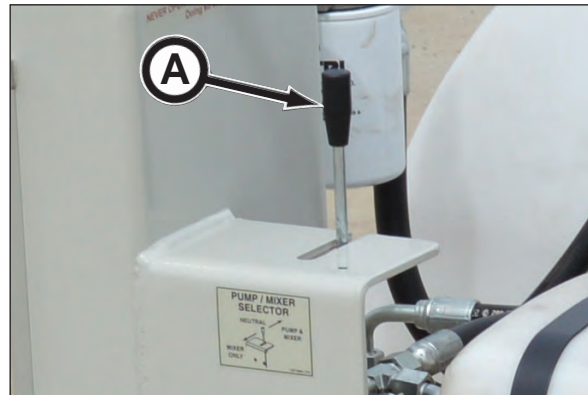

MIXER CONTROL

The mixer control (B) regulates the hydraulic oil to the mixer motor.

With the mixer control in the ON (9 o'clock) position, the hydraulic oil will flow to the mixer motor and then return to tank. If the Pump/Mixer selector is at the Mixer only position, the Mixer control must be at the ON position, otherwise the mixer will not operate.

With the mixer control in the OFF position (6 o'clock), the hydraulic oil will flow back to tank thus bypassing the mixer. If the Pump/Mixer selector is at the Pump & Mixer position, only the pump will operate, no mixing.

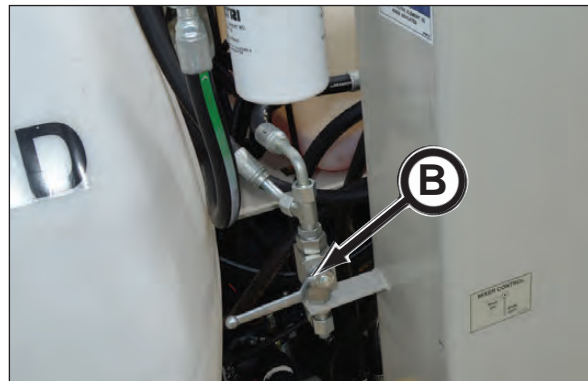

IN-TANK AGITATOR (MIXER)

The in-tank agitator system (C) aggressively mixes liquid based polymers and bentonite up to a viscosity (Marsh Funnel) of 50 seconds to prevent fluid settlement during mixer only or pump & mixer control functions. The agitator is controlled with the Pump/Mixer Selector. The Mixer control must be in the Mixer On position.

Before starting pump, be sure the Pump/Mixer Selector is in the neutral position.

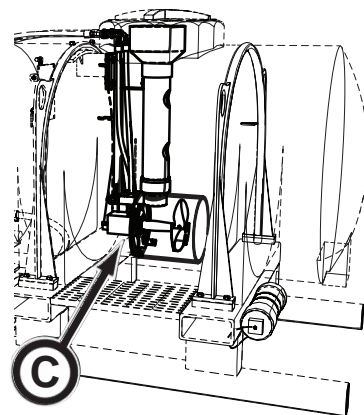

TANK SHUT OFF VALVE

The shut off valve is used to open and close the tank outlet.

NOTICE The tank shut off valve **MUST** be open before starting the 1325B/D Pump. Failure to do so could cause damage to pump.



HYDRAULIC TANK

The hydraulic tank provides hydraulic oil for the fluid pump and mixer motor. The tank includes a temperature and sight gauge (A).

Fill oil until fluid reaches high mark on sight gauge.

Recommended hydraulic oil:

Ambient Temp.	Hydraulic Oil
below 70°F (21°C)	ISO 46
above 70°F (21°C)	ISO 68

NOTICE Do not mix oil manufacturers or grades.

Hydraulic oil tank capacity is 15 gal. (57 L).



FLUID VOLUME CONTROL

Use the pressure (B) and return (C) shutoff valves on the pump shaft control to adjust the fluid volume.

NOTICE Reducing the engine RPM will also reduce the fluid volume.

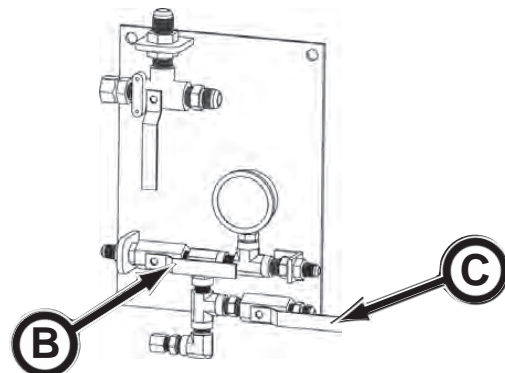

PRESSURE GAUGE

The piston pump pressure gauge (A) displays the hydraulic oil pressure of the piston pump.

Maximum pressure @ full engine RPM is 2,500 psi (17,237 kPa).



ENGINE FUEL LEVER

NOTICE For additional engine information, refer to your engine operator's manual.

The engine is equipped with a fuel lever valve (B). NEVER attempt to run the engine with the fuel lever in the OFF position. Starter damage may occur.

Operate the shutoff as follows:
ON - 6 o'clock Position
OFF - 3 o'clock Position

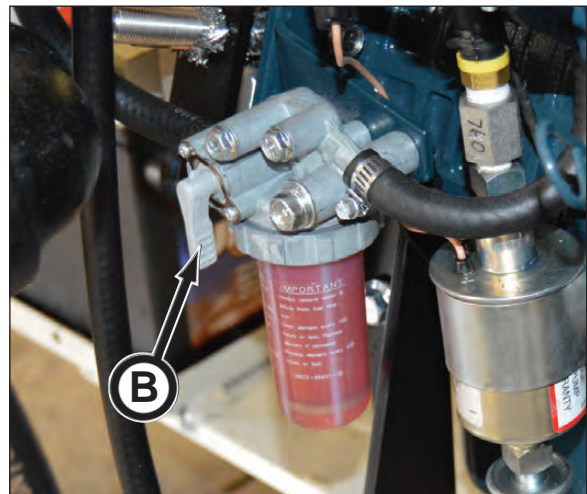

Engine Fuel Lever Shown in ON Position

ENGINE KEY SWITCH

NOTICE For additional engine information, refer to your engine operator's manual. Before starting engine, engine fuel lever must be in the ON position.

Turn key switch (C) clockwise to ON position. This provides power to the starting circuit.

Turning the key to OFF will shut down power to the engine, thus preventing battery to drain.

When pump operation is complete, be sure key is to the OFF position to prevent drain on the battery.



ENGINE SYSTEM MONITOR

NOTICE

For additional engine information, refer to your engine operator's manual.

The engine system monitor not only allows the operator to start and stop the engine, but in addition, the engine will be monitored with operational status and fault conditions.

Once the starter circuit has power (key switch to On position), press green Start button (A). This will start a preheating mode, check for proper oil pressure. When complete, the engine will start.

Stop the engine with the red Stop button (B). When lubrication pump operation is complete, be sure key switch is to the OFF position to prevent drain on the battery. The red Stop button (B) also acts as a reset button once the alarm condition is resolved.

Use navigation button (C) to scroll through operational items such as, battery voltage, engine hours and engine speed (RPM). The operational items will be displayed in the main status display (D).

If the alarm indicator (E) illuminates, the fault condition icon will be displayed in the main status display (refer to Fault Condition Icons in this section).

NOTICE

An Auto mode button (G) is also available. Refer to your engine operator's manual for more information.

- A - Engine Start Button
- B - Engine Stop/Reset Button
- C - Navigation Button
- D - Main Status Display
- E - Alarm Indicator
- F - Charging & Oil Pressure Indicators
- G - Auto Mode

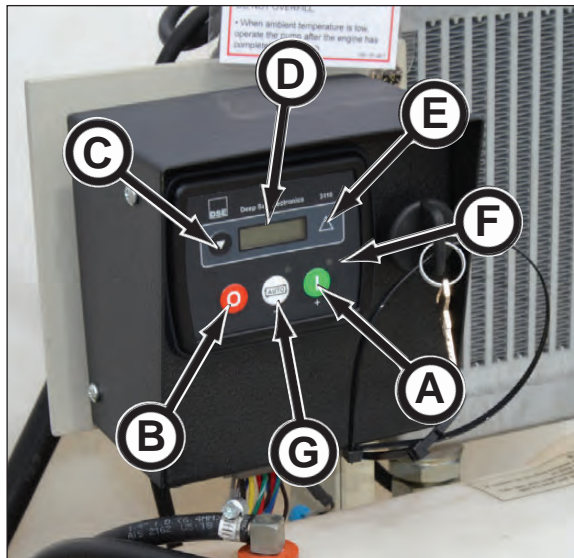

ENGINE THROTTLE

NOTICE

For additional engine information, refer to your engine operator's manual.

Use the engine throttle to increase or decrease the engine speed.

Increase Speed: Depress throttle button and pull out the throttle cable to desired speed and then release throttle button.

Decrease Speed: Depress throttle button and push in throttle cable to desired speed and then release throttle button.



PUMP SHAFT CONTROL

The shaft control (A) allows the operator to control the lubrication from the launch or reception shafts. The control is connected directly to the 1325B/D pump pressure and return ports.

Use a combination of the circuit ball valves (B and C) to control water/solution to component, washer wand or auxiliary, or to tank (Bypass Mode).

The control provides lubrication to:

- steering head for lubrication to outside of pilot tubes
- pilot tube adapter for lubrication to spoils for reaming head or open cutter head
- jetting on Powered Reaming Head
- washer wand or auxiliary

NOTICE

The washer wand or auxiliary is available in either the Jetting/Washer Mode or Bypass Mode.

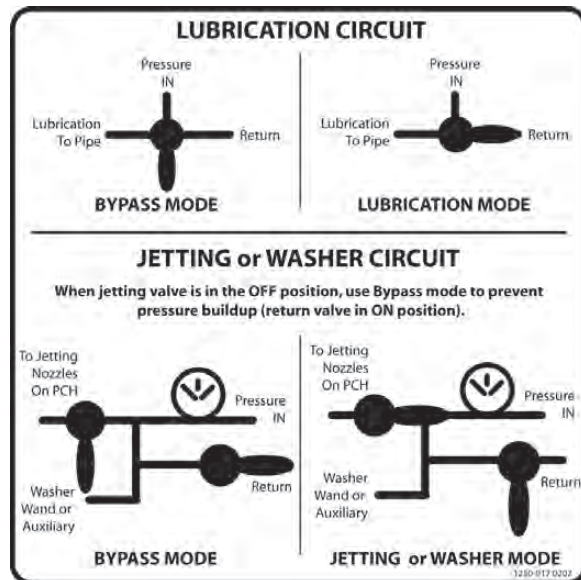
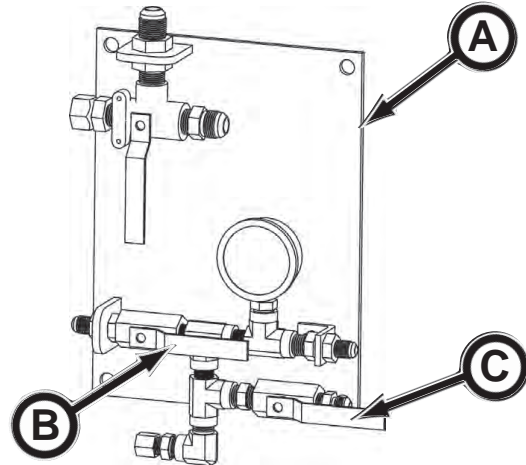

ENGINE FAULT CONDITION ICONS

NOTICE

For additional engine information, refer to your engine operator's manual.

When the alarm indicator (A) illuminates, the fault condition icon will be displayed in the main status display. The icon with description is shown below:

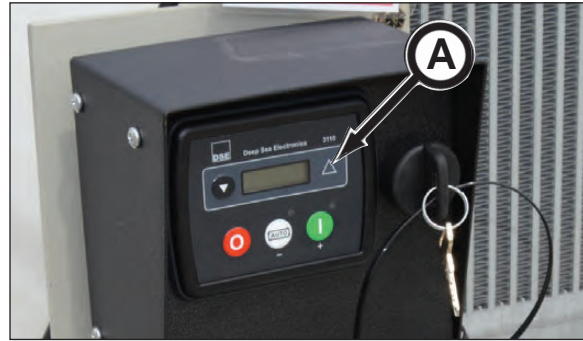

ICON	DESCRIPTION	
	AUXILIARY INPUTS	Auxiliary inputs can be user configured and will display the message as written by the user.
	FAIL TO START	The engine has not fired after the preset number of start attempts
	FAIL TO STOP	The module has detected a condition that indicates that the engine is running when it has been instructed to stop. NOTE:- 'Fail to Stop' could indicate a faulty oil pressure sensor - If engine is at rest check oil sensor wiring and configuration.
	LOW OIL PRESSURE	The module detects that the engine oil pressure has fallen below the low oil pressure pre-alarm setting level after the <i>Safety On</i> timer has expired.
	ENGINE HIGH TEMPERATURE	The module detects that the engine coolant temperature has exceeded the high engine temperature pre-alarm setting level after the <i>Safety On</i> timer has expired.
	UNDERSPEED	The engine speed has fallen below the underspeed pre alarm setting
	OVERSPEED	The engine speed has risen above the overspeed pre alarm setting
	CHARGE FAILURE	The auxiliary charge alternator voltage is low as measured from the W/L terminal.
	LOW FUEL LEVEL	The level detected by the fuel level sensor is below the low fuel level setting.
	BATTERY UNDER VOLTAGE / BATTERY OVER VOLTAGE	The DC supply has fallen below or risen above the low/high volts setting level.
	GENERATOR UNDER VOLTAGE	The generator output voltage has fallen below the pre-set pre-alarm setting after the <i>Safety On</i> timer has expired.
	GENERATOR OVER VOLTAGE	The generator output voltage has risen above the pre-set pre-alarm setting.
	GENERATOR UNDER FREQUENCY	The generator output frequency has fallen below the pre-set pre-alarm setting after the <i>Safety On</i> timer has expired.
	GENERATOR OVER FREQUENCY	The generator output frequency has risen above the pre-set pre-alarm setting.
	CAN ECU WARNING CAN ECU SHUTDOWN	The engine ECU has detected an alarm – CHECK ENGINE LIGHT Contact Engine Manufacturer for support.
	CAN DATA FAIL	The module is configured for CAN operation and does not detect data on the engine Can datalink.
	EMERGENCY STOP	The emergency stop button has been depressed. This a failsafe (normally closed to battery positive) input and will immediately stop the set should the signal be removed. Removal of the battery positive supply from the emergency stop input will also remove DC supply from the Fuel and Start outputs of the controller. NOTE:- The Emergency Stop Positive signal must be present otherwise the unit will shutdown.
	MAGNETIC PICKUP FAILURE	Pulses are no longer being detected from the magnetic pickup probe (3110-xxx-01 magnetic pickup version only)
	INTERNAL MEMORY ERROR	Either the configuration file or engine file memory is corrupted. Contact your supplier for assistance.

Pre-Start Inspection

⚠ WARNING

Do not operate this equipment until you read, study, and understand this manual, the engine owner's manual, and any other equipment manuals that may be used. A daily inspection of the equipment must be performed to prevent severe personal injury or death and equipment damage.

The contractor is fully responsible for the safety of all personnel on the job site. Check with the contractor that all site preparation requirements are in place. Be sure to comply with all MSHA and OSHA regulations, such as: an active safety program is in practice, a confined space permit (if needed) is issued, personal protective equipment is being worn; flammable, combustible, and hazardous materials are properly stored; and a lockout/tagout procedure is in place.

Use the following checklist ✓ as a guide for your daily pre-start inspection.

	1. Follow the MSHA (Mining Safety & Health Administration) and OSHA (Occupational Safety & Health Administration) regulations.
	2. Contractor is responsible for all personnel to wear proper protective equipment on the job site. Replace equipment if defective.
	3. Combustible, toxic and oxygen deficiency detectors MUST be in place, tested, and in proper working condition.
	4. Water/solution must be in tank prior to start up.
	5. Be sure Pump/Mixer Selector is in neutral position.
	5. Be sure pump shaft control is in Bypass position.
	6. The tank shutoff valve MUST be open prior to starting the pump.
	7. All pump connections must be secure to prevent cavitation.
	8. Clean strainer before operating pump.
	9. USE ONLY CLEAN WATER SOURCE.
	10. Check engine diesel fuel level. Add as needed.
	11. Check engine crankcase oil level. Add as needed.
	12. Check engine cooling air intake areas and external surfaces of engine. Be sure they are clean and obstructed.
	13. Check engine air cleaner components are in place and securely fastened.
	14. Check controls and switches for proper operation. Repair or replace if damaged or worn.
	15. Remove combustible or flammable materials from equipment. Store materials properly.
	16. Inspect equipment for damage. Repair or replace as needed.
	17. Thoroughly clean equipment of mud and dirt.
	18. Be sure all shrouds, covers and guards are in place and securely fastened before operation.
	19. Check for loose or missing hardware. Replace damaged or missing hardware.
	20. Check for worn, loose, or damaged wire connections. Repair or replace wiring connections.
	21. Tighten loose clamps or fittings.
	22. Check for fluid leaks. Repair leak or replace components.
	23. If operating in freezing weather, be sure to constantly circulate water/solution to prevent freezing.
	24. Keep job site clean and organized.

NOTES

Operation

OPERATING GUIDELINES

⚠ WARNING Do not operate this equipment until you read, study, and understand this manual, your engine owner's manual and any additional equipment manuals before you operate this equipment. Failure to do so, could result in severe personal injury or death.

1. Before operating, read and understand the Safety, Pre-Start Inspection, and Operation sections.
2. Do not operate this equipment while under the influence of alcohol, drugs, or medication.
3. Follow all Federal, State, and Local safety regulations and procedures.
4. Be sure OSHA prescribed safety protective equipment is being worn by all personnel.
5. Be sure the area is safe for operation. Keep work site clean and orderly.
6. Have a fully charged fire extinguisher on the job site at all times.
7. Position the pump on level ground.
8. Before operating, inspect equipment and conduct repairs as needed.
9. Test air monitoring and ventilation detectors for proper operation. Never enter a tunnel or shaft without combustible gas detectors and oxygen deficient detectors.
10. Never walk or work under any part of the excavator or crane and suspended loads.
11. Do not make any modifications to any Akkerman products. Doing so could cause structural failure and will void the warranty.
12. Check shields and guards. They must be in place and undamaged prior to operation.
13. The tank shutoff valve **MUST** be open and the tank filled with water/solution prior to starting the engine. Failure to do so will cause damage to pump after prolonged use without water.
14. Check all fluid levels (diesel fuel, hydraulic oil, engine oil) before operating.
15. Remove combustible or flammable materials from equipment.
16. Test all controls and switches to make sure they operate properly.
17. Place all controls in neutral or bypass mode before start up.
18. Eye, ear and respiratory protection **MUST** be worn by operator while filling tank with chemicals such as wetting agents, polymer, etc.
19. Never dry run or operate pump with tank shutoff valve closed.
20. In cold weather operation, constantly circulate water/solution to prevent freezing.
21. At daily shutdown or if pump will not be operated for a prolonged period of time in freezing weather, flush and drain pump and ALL fluid lines to prevent clogging or freezing.
22. If using a pressure washer wand, **NEVER** point the wand towards a person or animal. Also, be sure to release pressure after use and before performing maintenance to prevent accidental fluid injection.
23. If repairs are necessary to equipment, before making repairs, be sure to lockout tagout power source to prevent accidental starting of equipment.
24. If this manual is lost, contact your Akkerman Aftermarket Support Representative for a new manual or download this manual from the Akkerman web site at www.akkerman.com.

LUBRICATION GUIDELINES

The lubrication type or mixture is based on soil conditions, consistency, clay, sand, cobble, etc. Your polymer supplier can help you with the proper lubrication mixture based on your Geotech report for the project.

Displaceable Ground:

- Control the flow so there is no lubrication flowing out of the pilot tubes in the launch shaft.
- As a guideline, typical usage of lubricant in pilot tube annular space is approximately 1 gal per foot. For example, on a 300 ft drive, approximately 300 gallons will be required.

Soft Rock With Tri-Hawk® Drill Bit

- Control the flow so there is lubrication flowing (flush cuttings) out of the pilot tubes in the launch shaft.
- As a guideline, use up to 4 gpm of lubricant to flush cuttings to launch shaft and for cooling of tool.



Before shutting down the lubrication pump, loosening pilot tube joints or adding additional pilot tubes, vent the fluid into a catch pan to relieve pressure and prevent the fluid from entering the inner tube of the pilot tube.

If using a lubricant other than clean water during pilot tube installation, the lubricant in the pilot tubes **MUST** be flushed with clean water before removing pilot tubes from the reception shaft. Remove the steering head, and use clean water to flush the pilot tubes until the water is clear and free of sediment. Failure to do so will result in the clogging of the fluid and/or sight path of the pilot tubes.

Use of polymers and bentonite with fluid mixtures up to 50 seconds (Marshall Funnel) viscosity can be used in the 1325B/D Bentonite & Lubrication Pump.

As a guideline, typical usage of lubricant in overcut annular space is approximately:

Casing/PRH Size	Lubricant Per Ft	Lubricant Per 300 Ft Drive
11" Casing	1.5 gal.	450 gal.
14"/16" Casing/PRH 14/16	2.0 gal.	600 gal.
20" Casing/PRH 20	2.5 gal.	750 gal.

SETTING UP LUBRICATION PUMP

1. Position the 1325B/D Bentonite & Lubrication Pump on firm, level ground near desired area of use.

⚠ WARNING Do not position the lubrication pump near the edge of shaft where the ground may be unstable and cause a slide or cave-in. Doing so could cause severe injury or death.



2. Connect the lubrication (3/8 in.) hoses to the pump and shaft control as follows:
 - a. Connect the lubrication hose to pump return connection (A) and lubrication return connection (B) on shaft control.
 - b. Connect the lubrication hose to pump pressure connection (C) and lubrication Pressure IN connection (D) on shaft control.
3. Once the hoses are properly connected, proceed to Circuit Hookup on the next page (in this section).

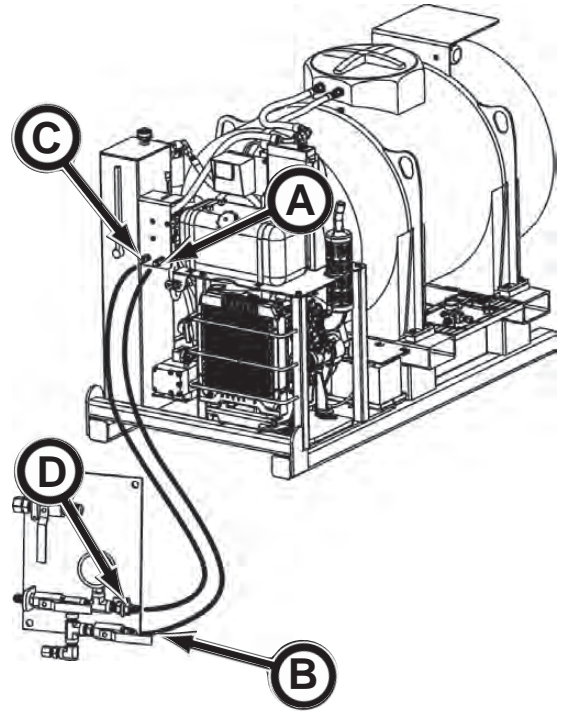

LUBRICATION CIRCUIT HOOKUP

The lubrication circuit provides lubrication/bentonite to:

- steering head for lubrication to outside of pilot tubes
- pilot tube adapter for lubrication to spoils for reaming head or open cutter head
- pilot tube adapter and reaming head for lubricating the outside of the casings
- jetting on Powered Reaming Head
- washer wand or auxiliary

Hookup hoses based on the jetting/lubrication requirement as follows:

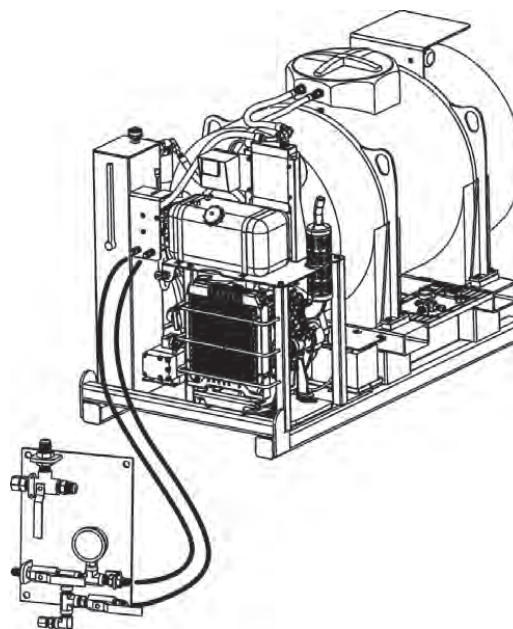

1. Lubricating Outside Of Pilot Tubes

Connect the lubrication hose (A) from the shaft control to the lube control valve (B) on the GBM. The lube control on the GBM is connected to the drive swivel which allows the lubricant to flow through the dual walled pilot tube annular space and out the steering head/Tri-Hawk® drill bit port.

- (Displaceable Ground) control the lubrication flow so there is no lubrication flowing out of the pilot tubes in the launch shaft.
- (Soft Rock With Tri-Hawk® drill bit) control the lubrication flow so there is lubrication flowing (flush cuttings) out of the pilot tubes in the launch shaft.
- before loosening pilot tube joints, vent the fluid into a catch pan to relieve pressure and prevent the fluid from entering the inner tube of the pilot tube.
- Use of polymers and bentonite with fluid mixtures up to 50 seconds (Marshall Funnel) viscosity can be used in the 1325B Bentonite & Lubrication Pump.

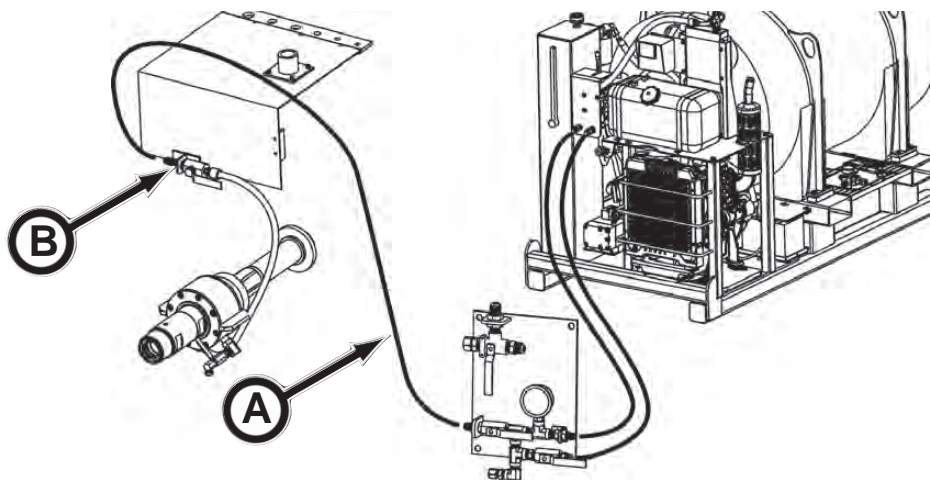

Steering Head Adapter With Steering Head Bit Fluid Path

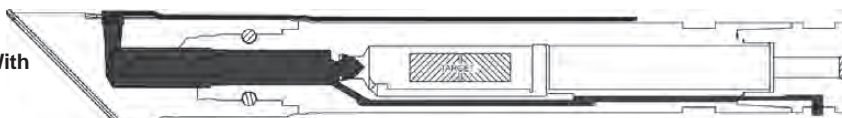

Pilot Tube To TriHawk Adapter With Tri-Hawk Drill Bit Fluid Path

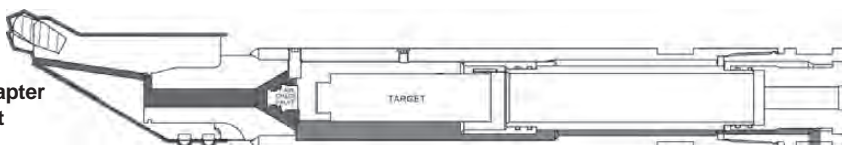

(Continued on next page)

Lubrication Circuit Hookup (continued)

2. Lubricating Spoils For Reaming Head or Open Cutter Head

Connect the lubrication hose (A) from the shaft control to the fluid connector (B) in reception shaft.

- the lubricant flows through the dual walled pilot tubes and out the lubrication port on the pilot tube adaptor to lubricate the spoils for the reaming head or open face cutter head.

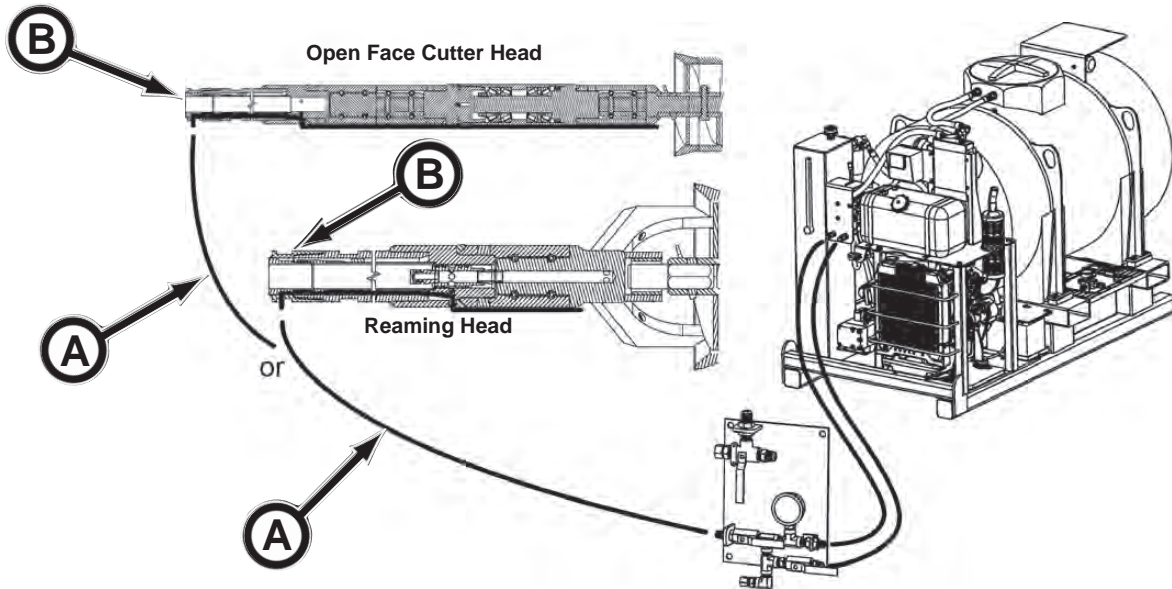

3. Lubricating Outside Of Casing With Reaming Head Assembly

Connect the lubrication hose (C) from the shaft control to the fluid connector (D) in reception shaft.

- the lubricant flows through the dual walled pilot tubes, pilot tube adaptor, and out the lubrication ports on the reaming head arms to lubricate the outside of casings.

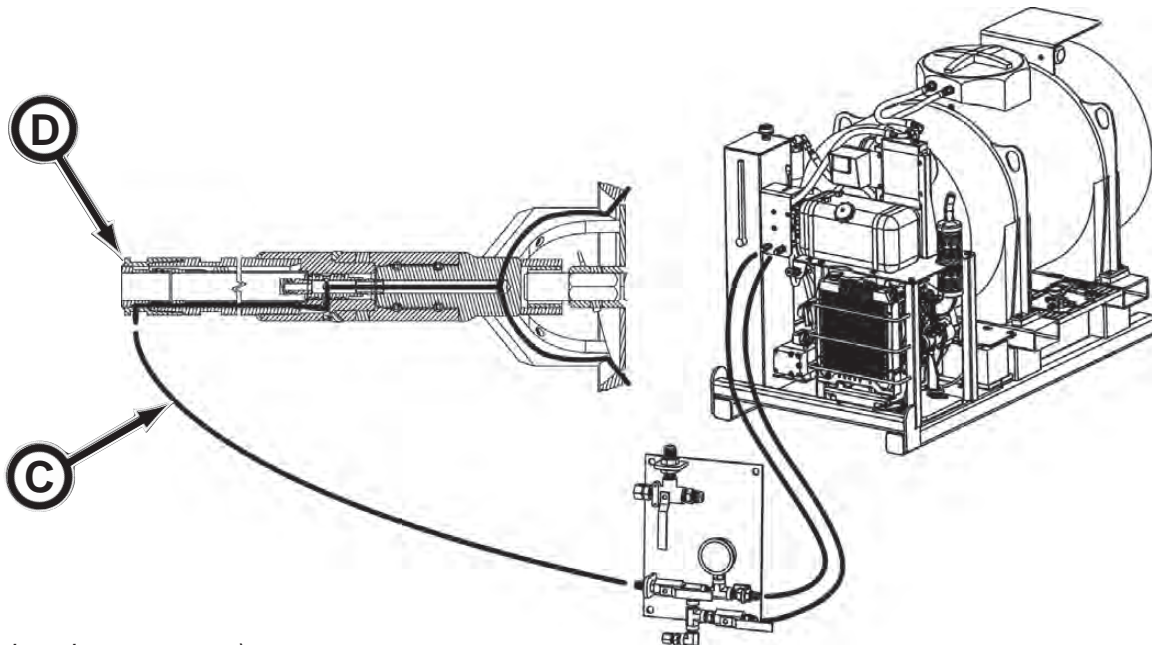

(Continued on next page)

Lubrication Circuit Hookup (continued)

4. Powered Reaming Head Jetting

Connect the lubrication hose (A) from the shaft control to the lubrication hose (B) in the rear of the Powered Reaming Head in the launch shaft.

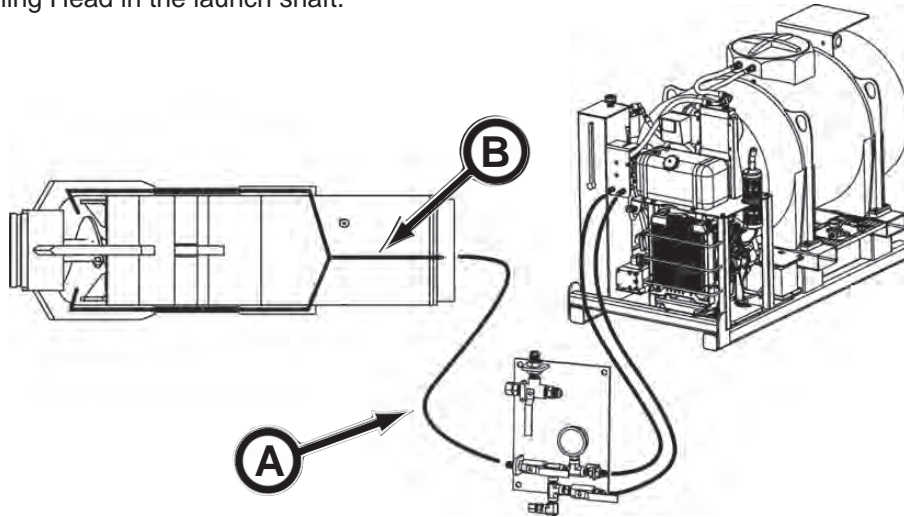

6. Using Pressure Washer Wand or Auxiliary

Connect the jetting hose (C) from the shaft control to the washer wand or other auxiliary device.

- refer to the wand or auxiliary device operation manual for the proper safe operation.

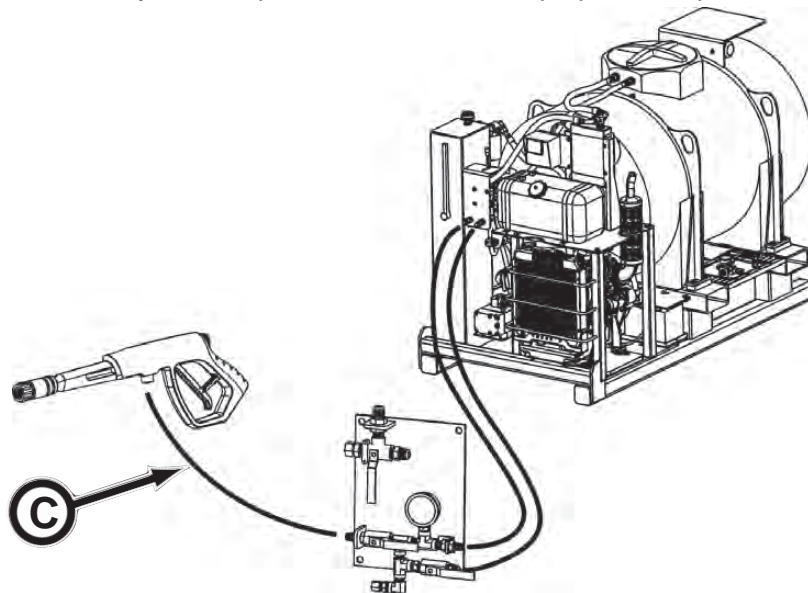

▲ WARNING Using the lubrication pump with a pressure washer wand can generate enough fluid pressure and velocity to penetrate skin resulting in serious personal injury.



Contact medical help immediately if fluid is injected into your skin. A serious infection or reaction can emerge without proper medical treatment.

NEVER point the wand towards a person or animal.

Be sure to release pressure after use and before performing maintenance to prevent accidental fluid injection.

Wear safety glasses and gloves, and depending on the wand use, a particle mask may be necessary.

USING SHAFT CONTROL FOR LUBRICATION

Use the ball valve(s) to control the lubrication circuit on shaft control as follows:

1. Set up Lubrication Pump (refer to Setting Up Lubrication Pump in this section)
 2. Hookup lubrication circuit to tooling (refer to Lubrication Circuit Hookup in this section).
 3. Perform start up procedure (refer to Start Up Procedure in this section).
-
5. Move pump shaft control ball valves (B and C) as shown to lubricate:
 - steering head for lubrication to outside of pilot tubes
 - pilot tube adapter for lubrication to spoils for reaming head or open cutter head
 - jetting nozzles on PRH
 - washer wand or auxiliary

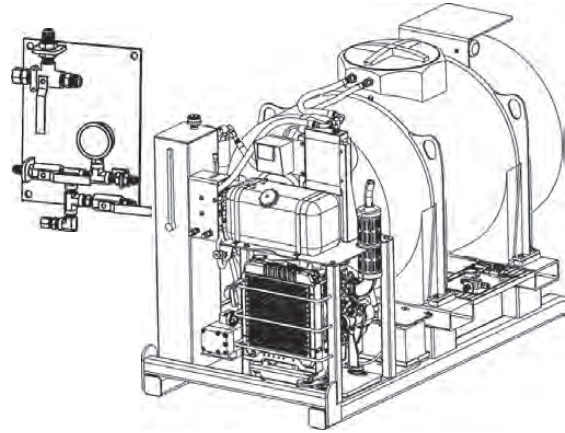

6. Move ball valve (D & E) as shown to:
 - Return solution to tank or bypass

7. Move ball valve (F & G) as shown to:
 - use washer wand or other auxiliary device

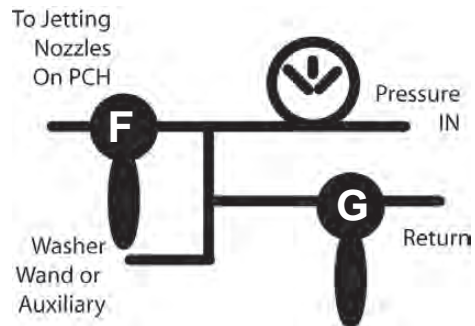
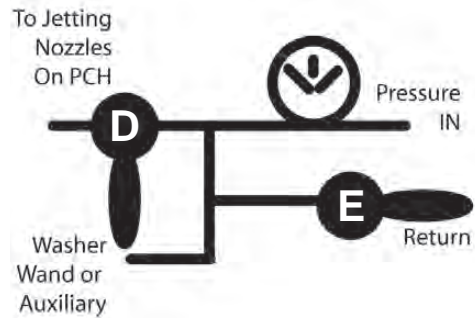
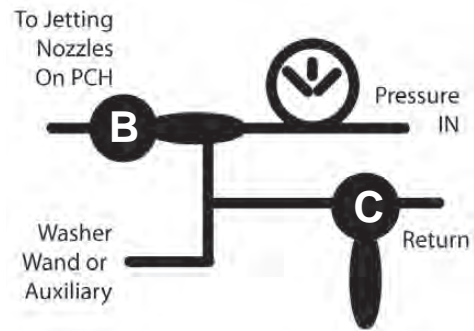

STARTING THE ENGINE

NOTICE

For proper new engine break-in, refer to your engine operator's manual. And for any additional engine information including cold weather starting, refer to your engine operator's manual.

1. Visually check the following items. If any leaks are found, perform repairs as needed.

- Check fluid levels (engine oil, diesel fuel and hydraulic oil). Fill as needed.
- Check for engine oil and fuel leaks.
- Check for damaged or missing parts and fasteners.
- Check the electrical harnesses for cracks, abrasions, and damaged or corroded connectors.

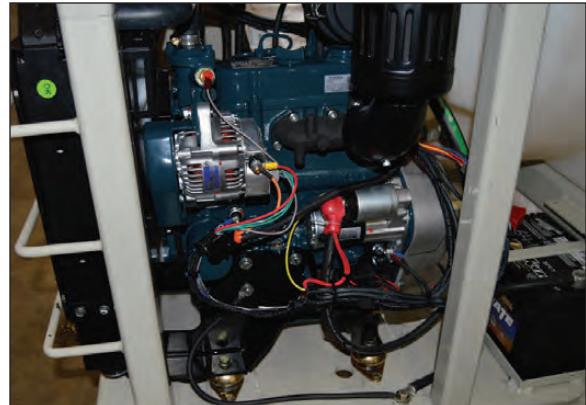

2. Place Pump/Mixer Selector (A) in the Neutral position.

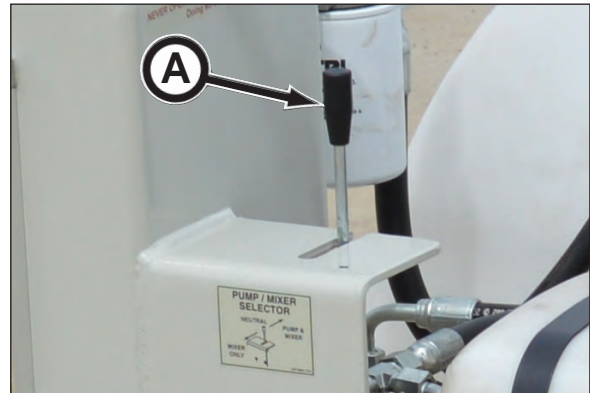

3. Move the fuel switch to the ON (6 o'clock) position.



4. Move the throttle control to low idle.



(Continued on next page)

5. Turn the key switch clockwise to the ON position.



6. Press GREEN button (A). This will start a timed preheating mode. Once preheat sequence is complete, the engine will start. If starter does not turn engine over within 10 seconds, immediately turn key switch to OFF position. Do not crank engine. Refer to engine manual.

NOTICE Never crank engine continuously for more than 10 seconds, otherwise starter will overheat. Allow a 60 second cool down period between starting attempts.

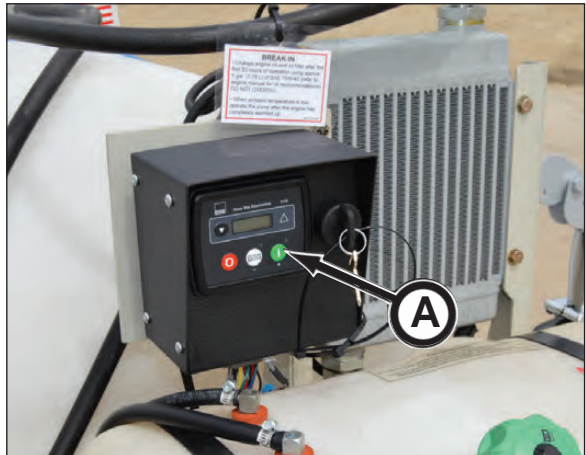

7. Allow engine to warm up for at least one minute before increasing engine speed.



8. Check for leaks.



SHUTTING DOWN THE ENGINE

1. Place Pump/Mixer Selector (A) in the Neutral position.

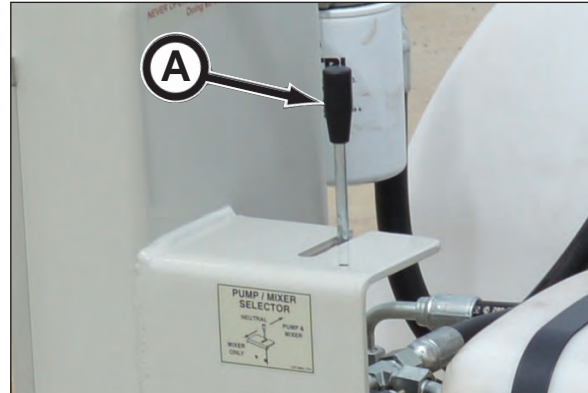

2. Move the throttle control to low idle.
3. Allow the engine to run at idle for 30 to 60 seconds before shutting down.



4. Shut down the engine by turning (counterclockwise) the key switch (B) to the OFF position. Remove key from switch to prevent accidental starting.

NOTICE The engine can also be shut down by pressing the red STOP button (C), though the key switch must also be turned to the OFF position, otherwise the battery will slowly drain since there is power to the starter.



5. Move the fuel switch to the OFF (3 o'clock) position.



(Continued on next page)

START UP PROCEDURE

Use the following procedure to properly start up the bentonite and lubrication pump.

1. Check the engine oil. Add oil if necessary using SAE 15W-40 oil (refer to engine manual for oil recommendations). Do not overfill.

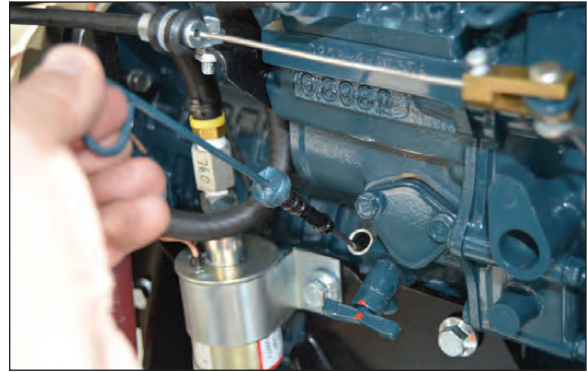

2. Check engine coolant level. Add coolant if necessary.



3. Check diesel fuel tank level. Add fuel if necessary.



4. Check radiator and oil cooler fins. Be sure they are clean and unobstructed.



(Continued on next page)

5. Check that the air cleaner components and all covers and guards are in place and securely fastened.

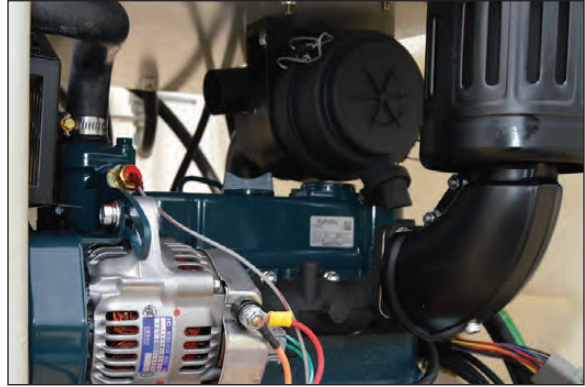

6. Check hydraulic tank oil level. Oil should be visible on sight gauge (A). Add oil if necessary using
 below 70°F: ISO-VG-46
 above 70°F: ISO-VG-68



7. Close tank shut off valve.



8. Remove and clean tank strainer. Replace strainer and secure strainer cap.



(Continued on next page)

9. Fill tank with CLEAN water/solution before starting the engine. Replace tank cover securely to prevent foreign objects from entering tank.



10. Open tank shut off valve .

NOTICE

NEVER dry run pump. Doing so may result in pump damage.



11. Place Pump/Mixer Selector (A) in the Neutral position.

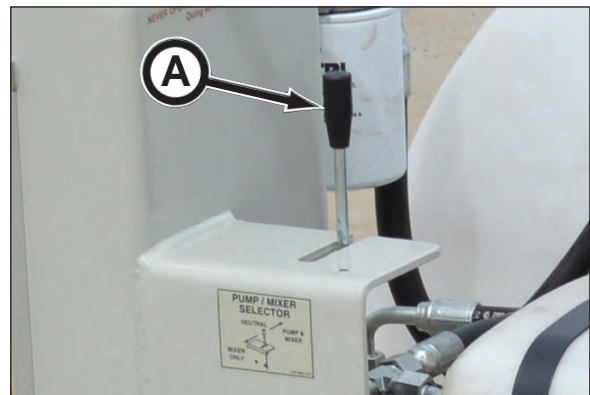

12. If shaft control is hooked to lubrication pump, arrange circuit valve in bypass mode to prevent pressure buildup in tooling.

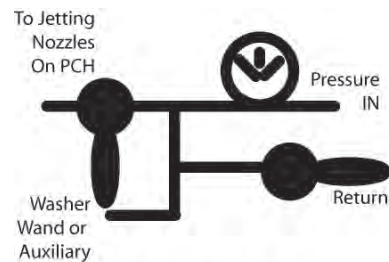

**JETTING CIRCUIT
BYPASS MODE**

(Continued on next page)

13. Be sure throttle control is in low idle position.



14. Before start up, check to be sure liquid is visible in clear tube (A) from tank to pump. When initially filling tank with liquid, an air lock may result between the tank outlet and the strainer assembly. If this should occur, slowly open stainer assembly cap to release air until liquid is visible in clear tube. DO NOT start engine if there is an air lock. Otherwise pump damage will occur if it operates without liquid for a prolonged period of time.

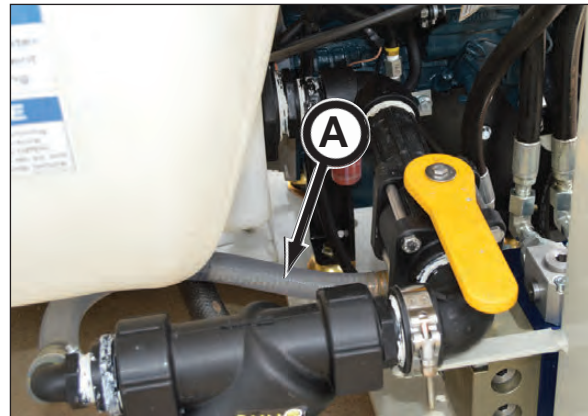

15. Remove all personnel away from lubrication pump.

16. Start engine (refer to Starting The Engine in this section) and allow engine to warm up for five minutes before applying a load.

NOTICE The engine has a break-in period in the first 5 hours of operation. Refer to the engine operator's manual for more information.

17. Check for leaks.



DAILY SHUTDOWN

1. Reduce engine speed by moving throttle control to low idle position.
2. Allow the engine to run at idle for 30 to 60 seconds before shutting down.



3. On shaft control, arrange jetting circuit valves in bypass mode.

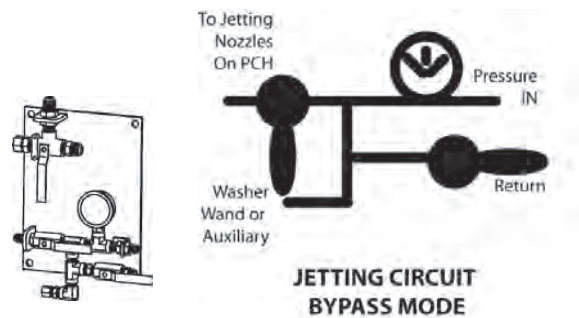

4. Place Pump/Mixer Selector (A) in the Neutral position.

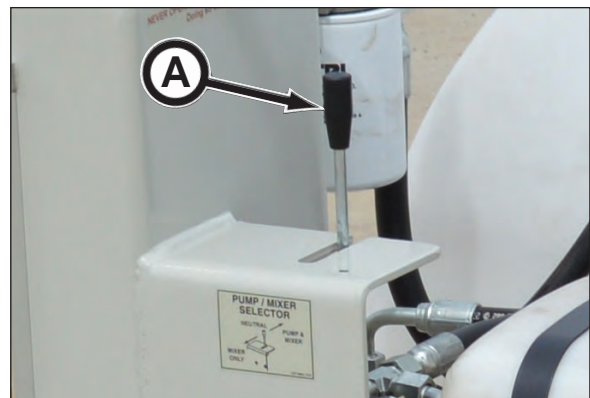

5. Shutdown engine. Refer to Shutting Down The Engine in this section.



(Continued on next page)

6. Move the fuel switch to the OFF (3 o'clock) position.



7. Close tank shut off valve on tank.
8. If the potential of freezing weather exists, refer to Cold Weather Protection in this section.



MIXING TANK

⚠ WARNING Exposure to chemicals may cause serious injury or death. **BEFORE** mixing chemicals or other agents in the water tank, be sure the area is well ventilated and other personnel removed from the area. Use proper personal protective equipment (PPE) per the chemical manufacturer's instructions.

The 1325B/D Bentonite and Lubrication Pump is capable of mixing liquid based polymers and bentonite up to **50 seconds (Marsh Funnel) viscosity**.

1. Fill water tank with clean water as needed per instructions on lubricant packaging.

NOTICE Before mixing polymers and bentonite, the water should be stabilized to the following pH and hardness levels:

pH	8.5 - 9.5
Water Hardness	do not exceed 200 ppm (depending on lubricant)

Note:

1. Pure water is neutral with a pH level of 7.
2. Soda ash helps lower water hardness as well as raise the pH simultaneously.

2. Open tank shut off valve.

NOTICE Be sure fluid is visible in clear tube (A) from tank outlet to fluid pump before starting engine. If not, an air lock is present and must be released by opening stainer assembly cap until fluid flows into clear tube. Otherwise, fluid from tank will not be pumped, causing pump damage when it operates without liquid for a prolonged period of time.

3. Place Pump/Mixer Selector (B) to the Neutral position.

4. Move Mixer Control (C) to the ON position

5. Start engine. **Run engine at full rpm to maximize the mixing efficiency.**

6. Move Pump/Mixer Selector to the Mixer position.

NOTICE Be sure mixer control is turned to the On position, otherwise the mixer will not operate.

7. Remove cover on tank to gain access to hopper (D).

8. Gradually pour lubricant into hopper in tank, following instructions on packaging (for example, depending on material, add material through the hopper at a rate not to exceed 3 - 5 minutes per 50 pounds).

9. Replace tank cover to prevent foreign objects from entering the tank.

10. Allow time for proper mixing of solution, typically 15 - 20 minutes. Follow instructions on packaging.

11. The tank solution is now available for use.

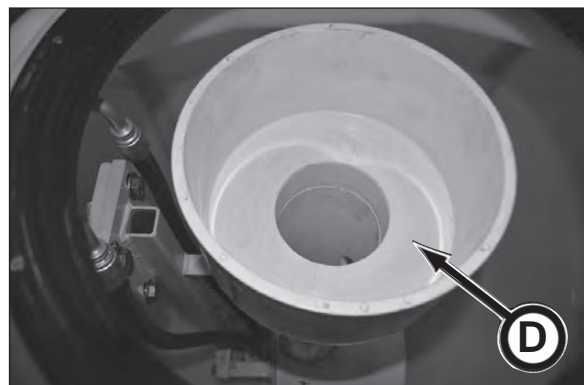
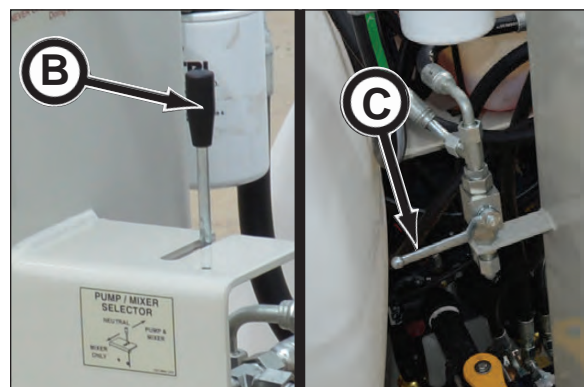
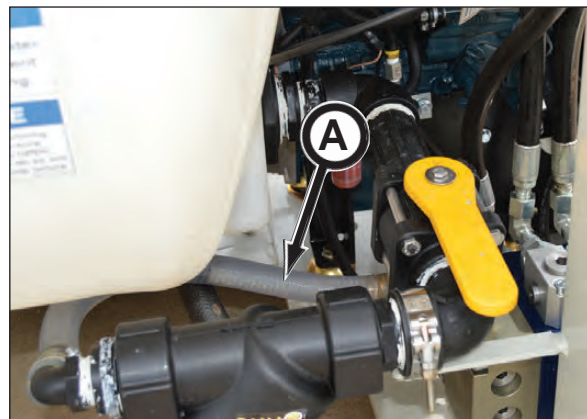

CLEANING TANK

⚠ WARNING Exposure to chemicals may cause serious injury or death.

BEFORE mixing chemicals or other agents in the water tank, be sure the area is well ventilated and other personnel removed from the area.

Use proper personal protective equipment (PPE) per the chemical manufacturer's instructions.

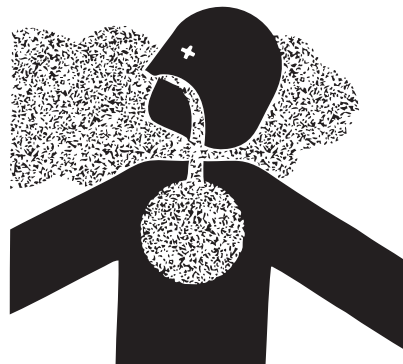

⚠ WARNING Do not allow anyone to enter tank. Tank fumes or becoming accidentally trapped may cause severe injury or death.

1. Fill tank with clean water.



2. Remove strainer.



3. Open tank shut off valve to flush tank with clean water.

NOTICE To help drain tank, CAREFULLY tip pump towards outlet of drain.

(Continued on next page)



NOTICE

If needed, the hopper can be removed from mix tube assembly for ease of cleaning tank. Be sure to replace hopper on mix tube assembly after cleaning.



4. Continue using clean water to flush the tank and water system components until the water is clear and free of sediment. Failure to do so will result in clogging of the fluid in the tank, hoses and/or components.
5. Once tank is clean and water emptied, close tank shut off valve.



6. Fill enough water in tank to cover outlet to prevent accidental dry running of pump.

NOTICE

NEVER operate pump without shut off valve open and tank filled with water.

IMPORTANT: If operating in freezing weather, the tank must be drained or a RV anti-freeze solution must be added to the tank to prevent component damage. Refer to Cold Weather Protection in this section.

7. Replace tank cover.



8. Replace strainer and secure strainer cap.



NOTES

COLD WEATHER OPERATION

Freezing temperatures during the tunneling process, creates the necessity to prepare the site and equipment for the cold weather. Failure to do so will cause damage to components and supporting equipment. Refer to Cold Weather Protection in this section for more information.

There are various methods of keeping equipment from freezing:

- The 1325B/D was designed to fit in a quadcon container (same container as the P100/P150 Power Packs) to provide a means to efficiently operate the pump in cold weather.
- When working with water, it needs to be constantly circulated to prevent freezing. Otherwise the equipment must be drained and/or treated with a RV anti-freeze solution to prevent freezing.
- If the 1325B/D Lubrication and Bentonite Pump will be shut off for a considerable length of time and the temperature is at or below freezing, the fluid must be drained or treated with RV anti-freeze.
- Water tanks must be drained or treated with RV anti-freeze.
- Drain hoses to prevent freezing and keep low areas properly drained to prevent freezing damage.
- For all equipment, use proper lubricant based on ambient temperature to prevent damage.
- Use compressed air to purge a system of water. Be sure the discharge valve is open before doing so.
- Install heaters for hydraulic systems.



If systems were shut down for freezing weather, be sure to start systems slowly and let them run for at least five minutes to allow for warm up and in the case of a pump, to displace any surface ice that may have accumulated in the fluid before going back to full operation mode.

Remember it is also critical to keep the work site safe and employees comfortable during the freezing weather. Good training, supervision, proper clothing and limiting personal exposure to the weather is essential for keeping personnel and equipment safe on the job site.

COLD WEATHER PROTECTION - DRAINING SYSTEM

NOTICE

To prevent damage to pump components in freezing weather, flush and drain pumps and ALL fluid lines. Failure to do so will cause damage to pump components. If using a RV Anti-Freeze solution for cold weather protection, refer to Cold Weather Protection - Using RV Anti-Freeze Solution in this section.



1. Release cam lock hose assembly (A) on the pump.

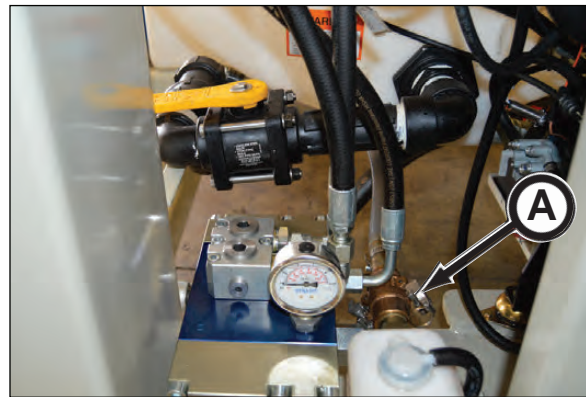

2. Remove pressure and return hoses or hose caps from pressure and return connections (B).

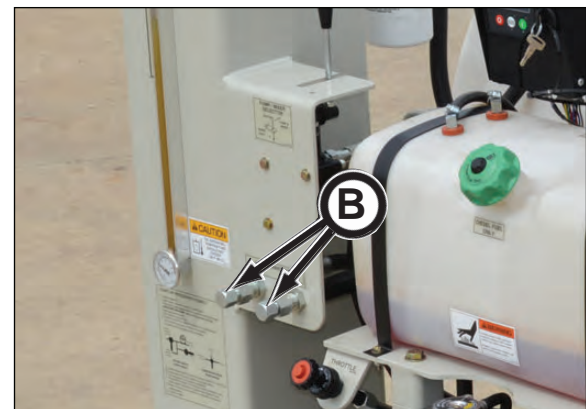

3. Remove strainer.



(Continued on next page)

4. Remove tank return hose (A).

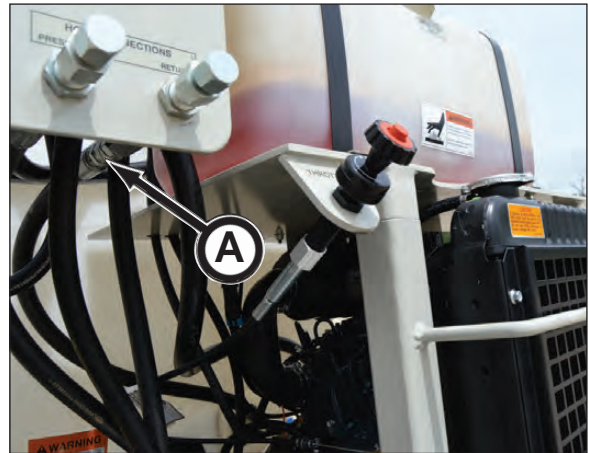

5. Open tank shut off valve.



6. Once all fluid is drained:

- reinstall pump cam lock hose assembly to pump
- reinstall pressure and return hoses or caps on connections
- reinstall strainer and cap
- replace tank return hose

NOTICE NEVER dry run pump. Doing so will damage pump.



COLD WEATHER PROTECTION - USING RV ANTI-FREEZE SOLUTION

NOTICE Akkerman Inc. **HIGHLY** recommends draining the system for cold weather protection. If the customer decides to use RV anti-freeze solution for cold weather protection, the customer is responsible for any damages occurred.

NOTICE To prevent component damage in freezing weather, the pump system **MUST** be drained or treated with a RV Anti-Freeze solution.

1. If tank is empty add approximately 4 - 5 gallons (15 - 19 L) of clean water. Proceed to step 3.
2. If tank is full, drain tank by releasing cam lock hose assembly (A) until 4 - 5 gallons (15 - 19 L) of water/solution is left in tank. Then reinstall cam lock hose assembly to pump. Proceed to step 3.
3. Add 4 - 5 gallons (15 - 19 L) of RV anti-freeze into tank. Be sure there is a 50/50 mixture of liquid to RV anti-freeze in the tank.

NOTICE Be sure to follow the proper solution instructions on the RV anti-freeze container.

4. Place Pump/Mixer Selector (B) to the Neutral position.
5. Move Mixer Control (C) to the OFF position.
6. On shaft control, arrange valves in bypass mode as shown.

NOTICE NEVER dry run pump. Doing so will damage pump.

7. Start engine and move Pump/Mixer Selector to the Pump/Mixer position. Cycle pump for at least two minutes to ensure the liquid/RV anti-freeze mixture is pumped through complete system.
8. Place Pump/Mixer Selector in Neutral position. Shut down engine and refer to engine operator's manual for cold weather protection.

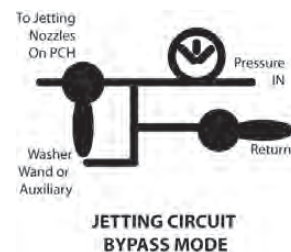
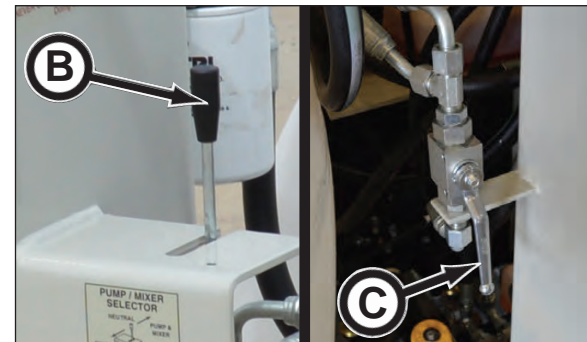
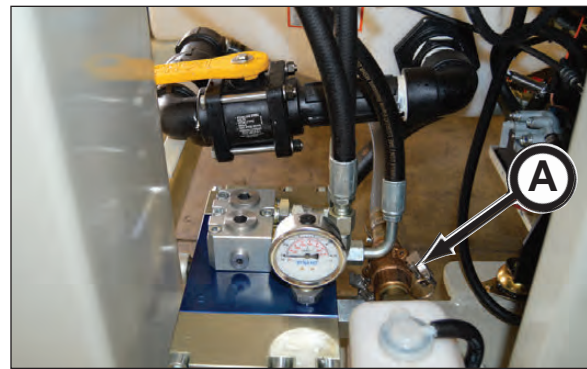

Transporting

TRANSPORTING GUIDELINES

1. Know the local, state, and federal transportation regulations.
2. Obtain required permits for transporting.
3. Remove any obstacles from the trailer floor.
4. Clean debris from equipment.
5. Load and unload on level ground.
6. Securely fasten the 1325B/D Bentonite & Lubrication Pump to trailer floor.
7. BEFORE lifting equipment with a hoist or other lifting device, the equipment lifting eyes and sling must be inspected for damage before lifting.
8. Observe the lifting instructions on the equipment.

LIFTING INSTRUCTIONS

- Frame weight:
 - with full tank: 4,000 lbs (1,814 kg)
 - with empty tank: 1,300 lbs (590 kg)
- Lifting with a crane requires a four part sling with legs a minimum of 10 ft (3 m) long.
- Frame MUST lift freely. If it is stuck to the ground, it MUST be broken loose prior to lifting.
- Frame lifting eyes MUST be inspected prior to each lift. Any damage MUST be repaired prior to lifting.

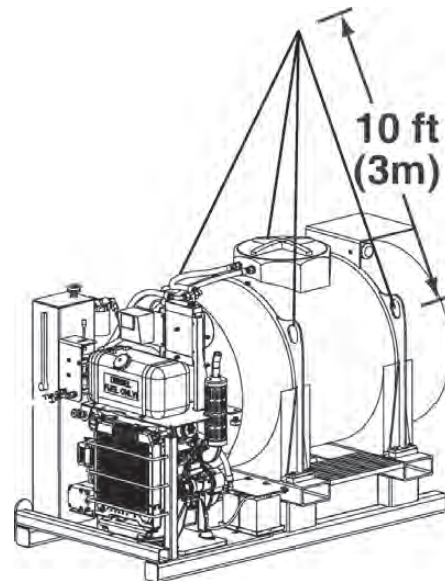

NOTES

Fuels & Lubricants

NOTICE

Use of inferior fuel or lubricants will affect the efficient performance of your 1325B/D Bentonite & Lubrication Pump. Always use high quality fuel and lubricants as specified in this section. Refer to the Periodic Maintenance section for proper lubrication quantity, maintenance intervals, and procedures.

NOTICE

For more information on maintaining your fuel and additional fuel specifications, refer to your engine owner's manual.

FUEL SPECIFICATIONS

NOTICE

For more information on maintaining your fuel and additional fuel specifications, refer to your engine manual.



Diesel fuel specification:

Use No.2-D S15 diesel fuel as an alternative to No.2-D, and use No.1-D S15 diesel fuel as an alternative to No.1-D for ambient temperatures below 14°F (-10°C).

The fuel must meet the following properties:

- Fuel cetane number of 45 minimum. A cetane rating greater than 50 is preferred.
- The sulfur content must not exceed 0.10% (10000 ppm) is strongly recommended.
- Bio-Diesel fuels (refer to engine manual).
- NEVER mix kerosene, used engine oil, or residual fuels with the diesel fuel.
- Water and sediment in the fuel should not exceed 0.05% by volume.
- Keep the fuel tank and fuel-handling equipment clean at all times.
- Poor quality fuel can reduce engine performance and/or cause engine damage.
- Fuel additives are not recommended. Some fuel additives may cause poor engine performance.
- Ash content not to exceed 0.01% by volume.
- Carbon residue content not to exceed 0.35% by volume. Less than 0.1% is preferred.
- Total aromatics content should not exceed 35% by volume. Less than 30% is preferred.

Fuel tank capacity is 8 gal. (30 L).



ENGINE OIL

NOTICE For more information on the engine oil specifications, refer to your engine operator's manual.

The engine is filled with SAE 15W40 oil.

Change the oil and filters after the first 50 hours of operation and every 100 hours thereafter with SAE 15W-40 engine oil or other oil viscosity based on the expected air temperature range during the period between oil changes as shown in graph.

Other high quality detergent oils, including synthetic, of API (American Petroleum Institute) are acceptable. Refer to the engine operator's manual for more information.

The engine oil capacity is approximately 4 qt (3.79 L). Oil level should be within the marks on the dipstick. Do not overfill!



Above 25°C (77°F)	SAE30, SAE10W-30 or 15W-40
-10 to 25°C (14°F to 77°F)	SAE10W-30 or 15W-40
Below -10°C (14°F)	SAE10W-30

HYDRAULIC TANK OIL

The hydraulic tank (A) is factory filled with ISO-VG-68, a premium AW (All-Weather) hydraulic oil.

Use ISO-VG-68 or equivalent when adding or changing lubricant.

Recommended: hydraulic oil:

<i>Ambient Temp.</i>	<i>Hydraulic Oil</i>
below 70°F (21°C)	ISO 46
above 70°F (21°C)	ISO 68

NOTICE Do not mix oil manufacturers or grades.

Hydraulic oil tank capacity is 15 gal. (57 L).



ENGINE COOLANT

⚠ WARNING Cooling system under pressure. Explosive release of HOT engine coolant can cause severe burns. SLOWLY remove the radiator cap ONLY if the engine is cool.

The engine radiator coolant is filled with a 50% mixture of long-life ethylene glycol engine coolant and soft, distilled, deionized, or demineralized water. NEVER use water only.

Refer to your engine manual for information regarding Long Life Coolant (LLC) or Extended Life Coolant (ELC).

NOTICE Refer to your engine manual for bleeding cooling system, if necessary.

The coolant capacity for the engine and radiator is approximately 3.28 qt. (3.1 L). Do not overfill.



STORING LUBRICANTS

Your equipment can operate at maximum performance only if clean lubricants are used. Use clean containers to handle all lubricants.

Lubricants should be stored in an area protected from dust, moisture, and other contaminants.

All lubricants must be stored at least 100 ft (30.5 m) from the portal, entrance to the tunnel, launch shaft or reception shaft.



NOTES

Periodic Maintenance

⚠ WARNING

Review the Safety section in this manual before performing maintenance. Failure to do so, could cause severe injury or death.

The requirements for maintenance are shown on the maintenance charts in this section. Intervals of maintenance are based on normal operating conditions. If operating under more difficult conditions, use a shorter time interval between maintenance.

FLUIDS UNDER PRESSURE

⚠ WARNING

Escaping fluids under pressure can penetrate your skin causing serious injury.

Release all pressure before performing maintenance or repairs. Never weld near pressurized fluid lines.

DO NOT use your hands to check for leaks. When searching for leaks, use a piece of wood or cardboard.

Contact medical help immediately if any fluid is injected into your skin. A serious infection or reaction can emerge without proper medical treatment.



USING A PRESSURE WASHER WAND

⚠ WARNING

Using the lubrication pump with a pressure washer wand can generate enough fluid pressure and velocity to penetrate skin resulting in serious personal injury.

Contact medical help immediately if fluid is injected into your skin. A serious infection or reaction can emerge without proper medical treatment.

NEVER point the wand towards a person or animal.

Be sure to release pressure after use and before performing maintenance to prevent accidental fluid injection.

Wear safety glasses and gloves, and depending on the wand use, a particle mask may be necessary.



AVOID PINCH POINTS

⚠ WARNING

Moving parts or the mishandling of parts can cause severe personal injury.

Keep hands away from moving parts.

Watch your fingers, hands, and legs while equipment is in operation.

Handle parts carefully to avoid crushing and pinch point hazards.



MAINTENANCE CHARTS

NOTICE

Use the item number in the chart to refer to the detailed maintenance instructions later in this section.

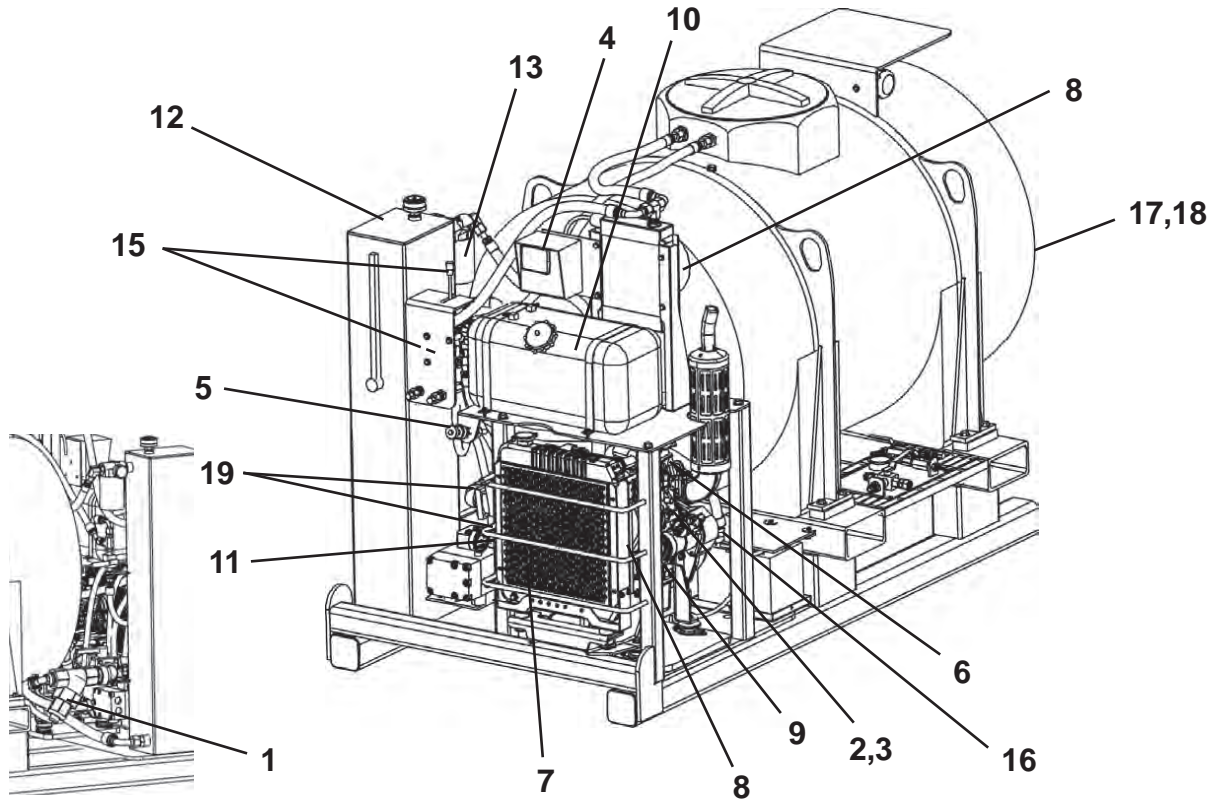

*DAILY OR EVERY 10 HOURS OF OPERATION

ITEM	COMPONENT	SERVICE	REQUIREMENT	MATERIAL
1.	Tank Strainer	Clean	If damaged, replace with new.	
2.	Engine	Inspect	Visually inspect for damage.	
3.	Engine Crankcase**	Check Oil Level	Add oil as needed.	See Section 8
4.	Engine System	Inspect	Inspect for proper operation.	
5.	Engine Speed Cntl	Check	Check for smooth operation.	
6.	Air Cleaner Dust Unloader	Clean Out		
7.	Radiator	Check Coolant Level	Add coolant as needed.	See Section 8
8.	Fans	Inspect Fan & Guard	If damaged, replace with new.	
9.	Fan Belt	Inspect	If cracked or worn, replace with new.	
10.	Fuel Tank	Check Fuel Level	Add fuel as needed.	See Section 8
11.	Fuel/Water Separator	Inspect For Water	Drain water until fuel is visible.	
12.	Hydraulic Tank	Check Fluid Level	Add hydraulic fluid as needed.	See Section 8
13.	Hyd Return Filter	Check Indicator	Replace filter per indicator.	Return Filter
14.	Covers & Guards^	Inspect	Replace if damaged.	
15.	Valves & Levers	Inspect	Inspect for proper operation.	
16.	Wiring & Cables	Inspect	If damaged, replace with new.	
17.	Water/Solution Tank	Inspect	Repair or replace if damaged.	
18.	Water/Solution Tank	Flush	Flush in freezing weather or is	
19.	Hoses & Tube	Check	Replace if damaged.	
20.	Decals^	Inspect	If damaged, replace with new.	

* Refer to your engine operator's manual for additional maintenance information.

** During engine break-in period, change the oil for the first time at 50 hours of operation & every 100 hours.

^ Not Shown

NOTICE Use the item number in the chart to refer to the detailed maintenance instructions later in this section.

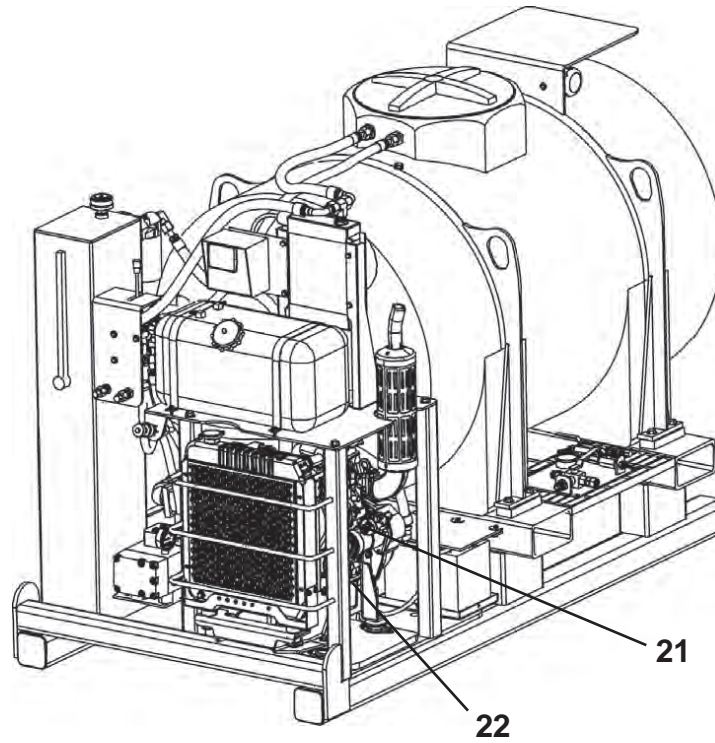

***FIRST 50 HOURS OF OPERATION & EVERY 100 HOURS THEREAFTER**

ITEM	COMPONENT	SERVICE	REQUIREMENT	MATERIAL
21.	Engine Crankcase	Drain & Fill	Replace with new oil.	SAE15W-40
22.	Fan Belt	Check & Adjust	.28 - .35 in. Deflection @ 22 ft lbs	

* Refer to your engine operator's manual for additional maintenance information.

NOTICE

Use the item number in the chart to refer to the detailed maintenance instructions later in this section.

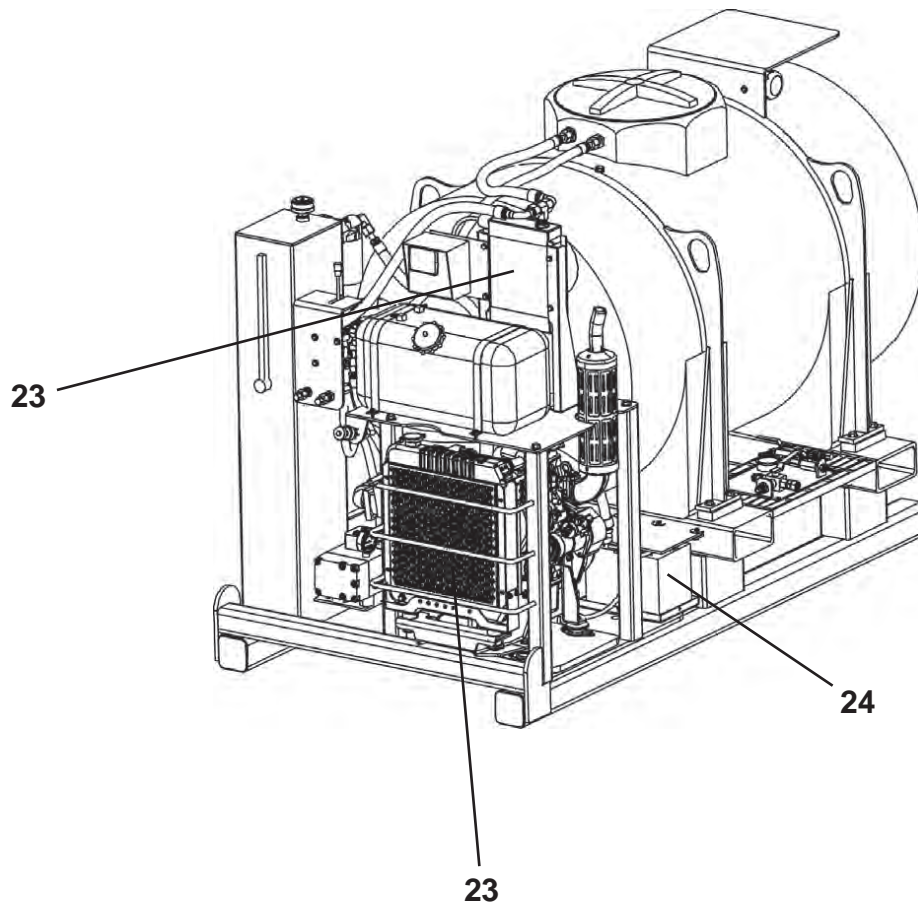

***WEEKLY OR EVERY 50 HOURS OF OPERATION**

ITEM	COMPONENT	SERVICE	REQUIREMENT	MATERIAL
23.	Radiator/Oil Cooler Fins	Check & Clean	Repair or replace if damaged.	
24.	Battery	Check	Check for damage or frayed cables.	Battery/Cable

* Refer to your engine operation manual for additional maintenance information.

NOTICE

Use the item number in the chart to refer to the detailed maintenance instructions later in this section.

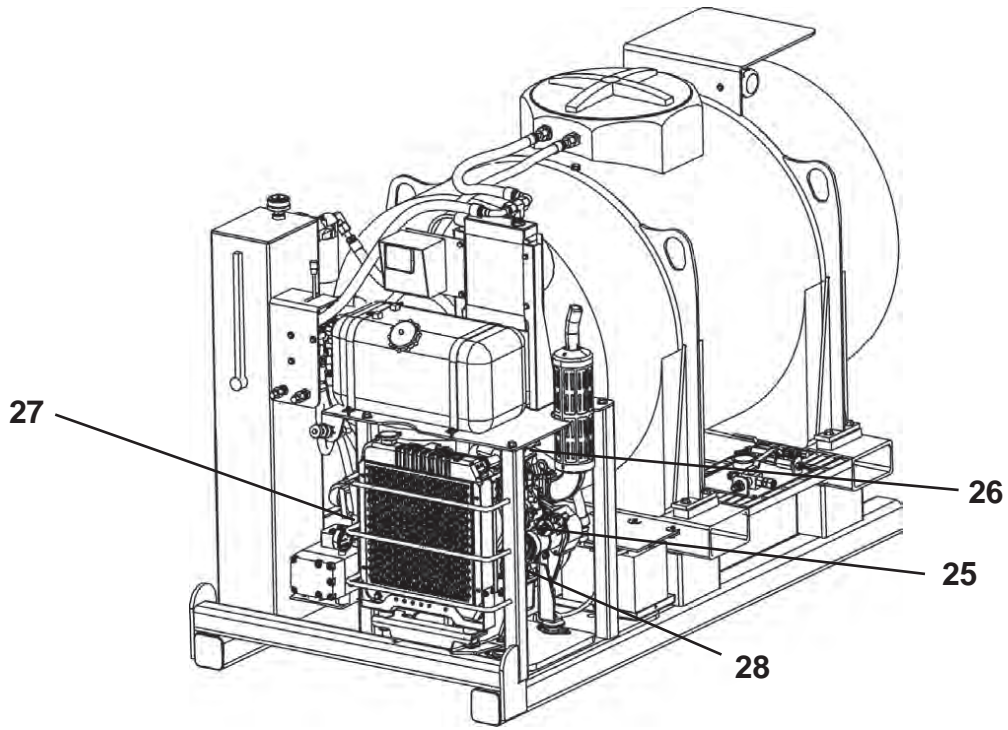

***EVERY 100 HOURS OF OPERATION**

ITEM	COMPONENT	SERVICE	REQUIREMENT	MATERIAL
25.	Engine Crankcase	Drain & Fill	Replace with new oil.	See Section 8
26.	Air Cleaner	Clean Element		
27.	Fuel Filter**	Clean Element	.28 - .35 in. Deflection @ 22 ft lbs	
28.	Fan Belt	Check & Adjust		

* Refer to your engine operator's manual for additional maintenance information.

** Replace fuel filter every 400 hours of operation.

NOTICE

Use the item number in the chart to refer to the detailed maintenance instructions later in this section.

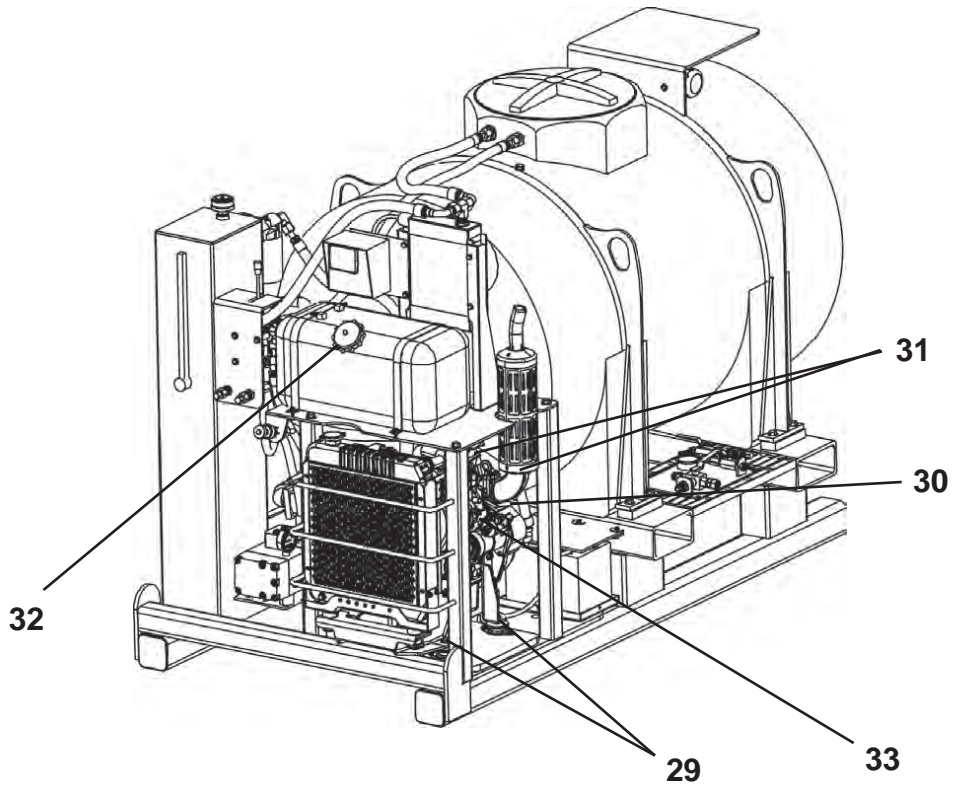

***MONTHLY OR EVERY 200 HOURS OF OPERATION**

ITEM	COMPONENT	SERVICE	REQUIREMENT	MATERIAL
29.	Engine Mtg Bolts	Inspect	If damaged, replace with new.	
30.	Pump Mtg Bolts	Inspect		
31.	Air Intake & Exhaust	Inspect		
32.	Fuel Tank Cap	Inspect		
33.	Engine	Service	Refer to Engine Manual.	

* Refer to your engine operation manual for additional maintenance information.

NOTICE

Use the item number in the chart to refer to the detailed maintenance instructions later in this section.

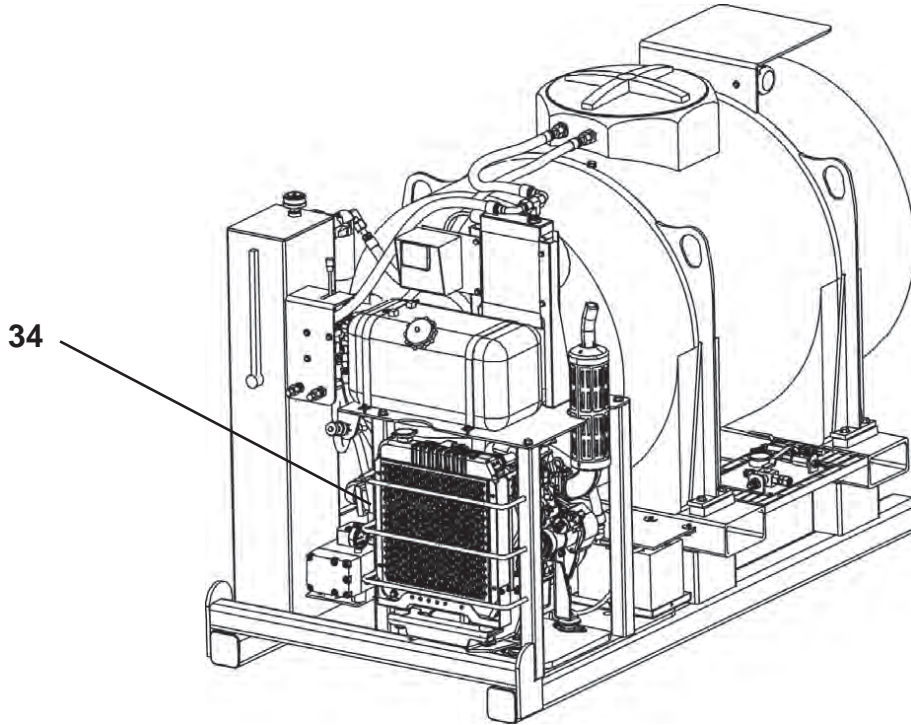

***EVERY 400 HOURS OF OPERATION**

ITEM	COMPONENT	SERVICE	REQUIREMENT	MATERIAL
34.	Fuel Filter	Replace Element		

* Refer to your engine operation manual for additional maintenance information.

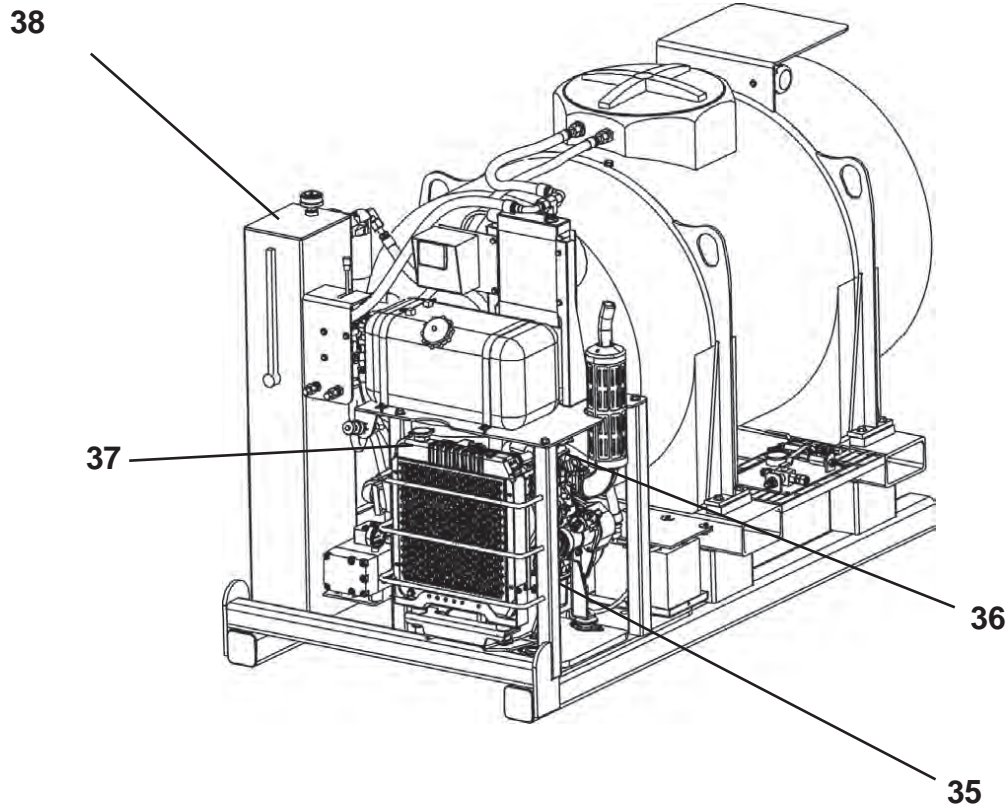

***EVERY 500 HOURS OF OPERATION**

ITEM	COMPONENT	SERVICE	REQUIREMENT	MATERIAL
35.	Fan Belt	Replace Belt	.28 - .35 in. Deflection @ 22 ft lbs	See Section 8
36.	Air Cleaner	Replace Element		
37.	Cooling System	Inspect		
38.	Hydraulic Tank	Drain & Fill	15 gal. (57 L)	

*** Refer to your engine operation manual for additional maintenance information.**

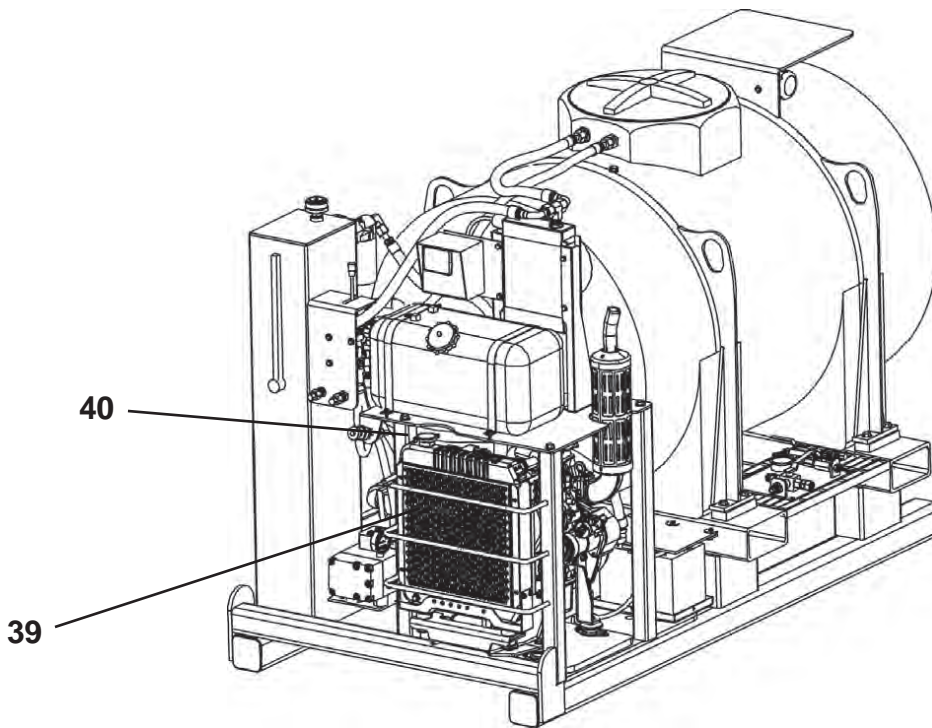

***EVERY 1000 HOURS OF OPERATION**

ITEM	COMPONENT	SERVICE	REQUIREMENT	MATERIAL
39.	Engine Cooling Sys.	Flush & Fill	Refer to engine manual.	Water/Anti-Freeze

* Refer to your engine operation manual for additional maintenance information.

***EVERY 2000 HOURS OR EVERY 2 YEARS OF OPERATION**

ITEM	COMPONENT	SERVICE	REQUIREMENT	MATERIAL
40.	Fuel System & Cooling System Hoses	Replace		

* Refer to your engine operation manual for additional maintenance information.

NOTICE

Use the item number in the chart to refer to the detailed maintenance instructions later in this section.

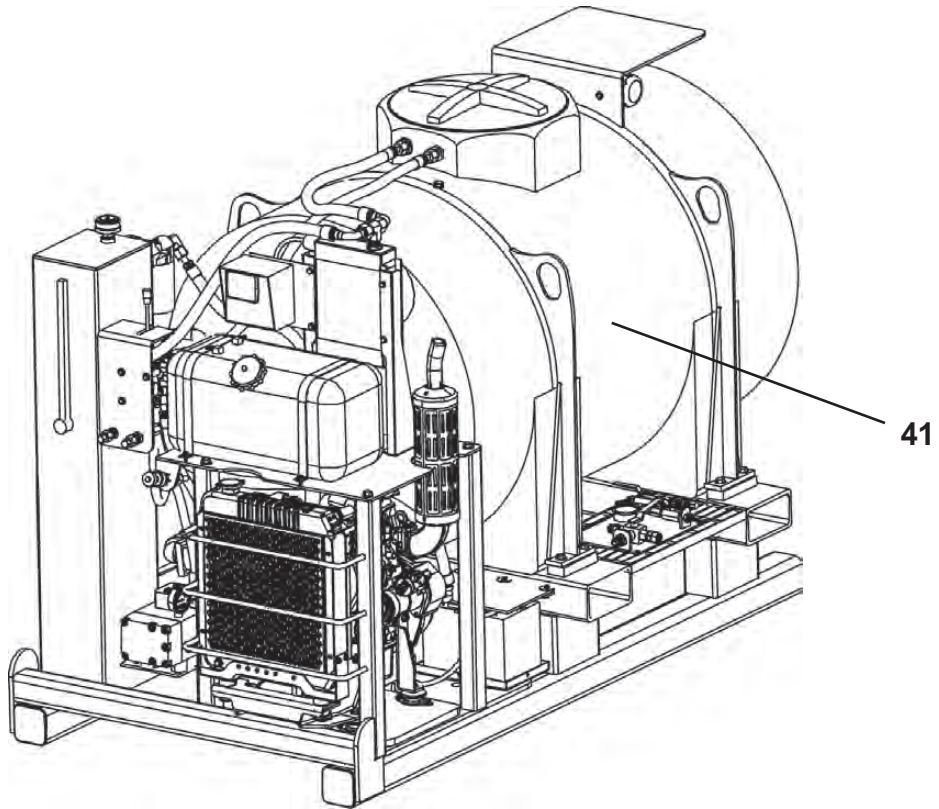

AFTER EACH DRIVE

ITEM	COMPONENT	SERVICE	REQUIREMENT	MATERIAL
41.	Water/Solution Tank	Flush	Flush tank and prepare for storage.	

DAILY OR EVERY 10 HOURS OF OPERATION

NOTICE

Refer to your engine operator's manual for additional maintenance information.

1. CLEAN TANK STRAINER

Clean tank strainer with water or other non-abrasive cleaner.

If damaged, replace with new.



2. INSPECT ENGINE

Perform an overall visual inspection of the engine:

- check for engine oil leaks
- check for fuel leaks
- check for damaged or missing parts

If leaks appear or any parts are damaged, repair or replace before operating the engine.



3. CHECK ENGINE CRANKCASE OIL LEVEL

Check engine oil level on dipstick. Do not fill above the top mark on the dipstick.

ALWAYS keep oil level within the marks on dipstick when operating engine.

If necessary, add SAE 15W40 engine oil. See Engine Oil in the Fuels & Lubricants section for oil specification.

NOTICE

After the first 50 hours of operation, replace engine oil and filter.



4. INSPECT ENGINE SYSTEM CONTROL

NOTICE For additional engine information, refer to your engine operation manual.

Check the engine system controls to be sure they are operating properly.

If any faults are visible on the system display, refer to Fault Condition Icons in Section 4, Control & Instruments for a detailed description of the fault.



5. CHECK ENGINE SPEED CONTROL

NOTICE For additional engine information, refer to your engine operator's manual.

Check throttle for smooth operation. Clean or lubricate as necessary. Check for proper adjustment.

If the throttle does not move smoothly after cleaning or lubrication, replace cable before operating engine.



6. CLEAN OUT DUST UNLOADER VALVE

Squeeze air cleaner dust unloader valve on air cleaner assembly to release any trapped dirt particles. If the sealing top of the valve is damaged, life of the air filter element will be greatly reduced.



7. CHECK COOLANT LEVEL

⚠ WARNING Cooling system under pressure. Explosive release of HOT engine coolant can cause severe burns. SLOWLY remove the radiator cap ONLY if the engine is cool.



1. Visually check the cooling system for leaks. Tighten all clamps securely.
2. Check to be sure the coolant level in the engine coolant reservoir (A) is between the low and high marks. Add coolant mixture if needed. Refer to Engine Coolant in the Fuels & Lubricants section of this manual.
3. Inspect all cooling system hoses. If the hoses are found to be in a hard, weak, or cracked condition, replace the hose(s).
4. Check the radiator for bent fins. Carefully straighten fins.
5. Check the inlet and outlet tubes for cracks, kinks, dents, or fractured seams. Repairs must be made by a qualified radiator technician.



8. INSPECT FAN & FAN GUARD)

⚠ WARNING NEVER operate engine without fan guards in place. Serious personal injury could result if contact is made with rotating fans.

With engine shut off and key removed from key switch to prevent accidental starting, check radiator and oil cooler fans for cracks, and bent or loose blades. Replace damaged fan(s) and fan guard(s).

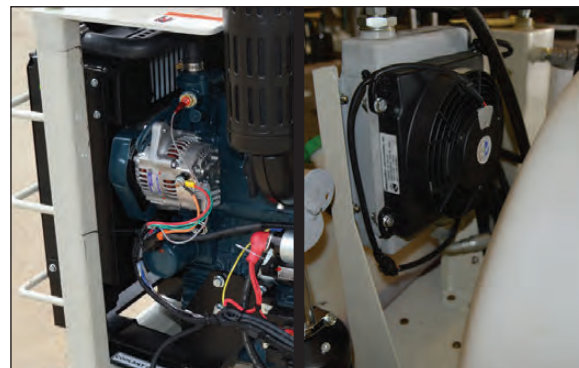

9. INSPECT FAN BELT

Visually inspect engine fan belt (B) for cracking, fraying or missing material. Replace belt as needed.

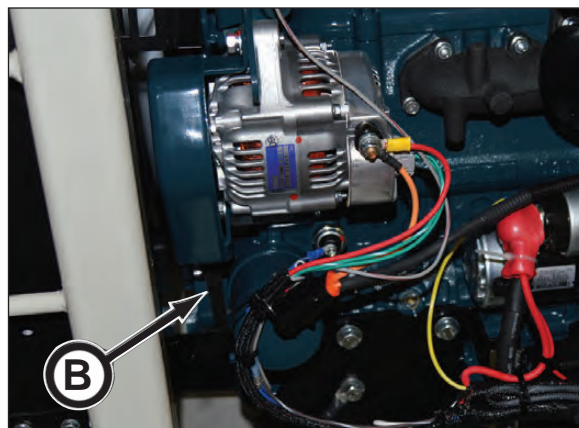

10. CHECK FUEL TANK LEVEL

⚠ WARNING Diesel fuel is extremely flammable and explosive. Handle with care. DO NOT refuel while smoking or when near open flame or sparks. Do not fill the fuel tank while the engine is hot or running.

Have a fire extinguisher available at all times. Keep the fire extinguisher fully charged.

1. Shut off engine before refueling.
2. Clean area around the fuel cap.
3. Remove the fuel cap from the fuel tank.
4. Refuel (refer to section 8 for Fuel Specification) until fuel tank is full. NEVER overfill the fuel tank. Wipe up spills.
5. Replace fuel cap.
6. Check fuel lines for cracks, fraying or other damage or leaks. Repair as needed.



11. CHECK FUEL/WATER SEPARATOR

Check the fuel/water separator for water and/or sediment.

If water and/or sediment is present:

1. Shut off engine.
2. Move the fuel lever (A) to the OFF position.
3. Remove the screw ring (B).
4. Carefully remove the filter bowl (C)
5. Pour out the fuel and water from the bowl.
6. Replace bowl into fuel head assembly (D). Be sure the o-ring is properly seated into the head assembly before reinstalling the bowl.
7. Tighten the bowl to the head assembly using the screw ring.
8. The fuel system requires bleeding. An appropriate sized catch pan will be required to collect fuel during the bleeding process.
9. Move the fuel lever (E) to the ON position.
10. Loosen air vent plug (F) of the head assembly a few turns.
11. Retighten the plug when only fuel is visible, no bubbles.
12. If needed, open the air vent plug (not shown) on top of the fuel injection pump.
13. Retighten the plug when only fuel is visible, no bubbles.
14. Start engine and check for leaks.

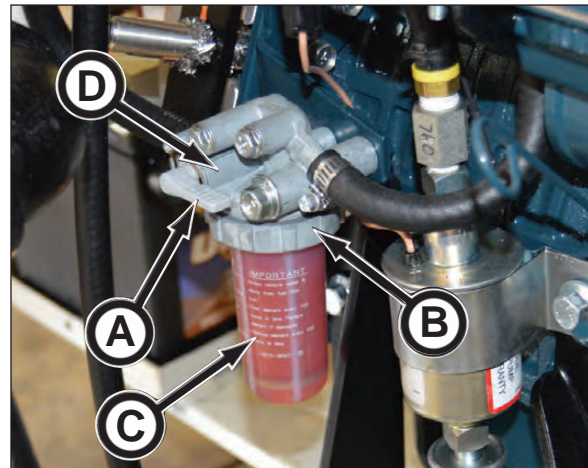

Engine Fuel Lever Shown in OFF Position

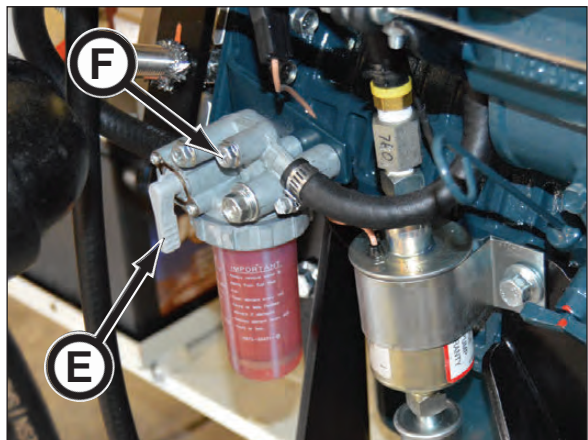

Engine Fuel Lever Shown in ON Position

12. CHECK HYDRAULIC TANK OIL LEVEL

Check hydraulic tank oil level gauge (A). Add hydraulic oil, if necessary.

The hydraulic tank is filled with ISO-VG-68 Premium AW Hydraulic Oil. Refer to Hydraulic Tank in the Fuels & Lubricants section for more information.

Hydraulic oil tank capacity is 15 gal. (57 L).

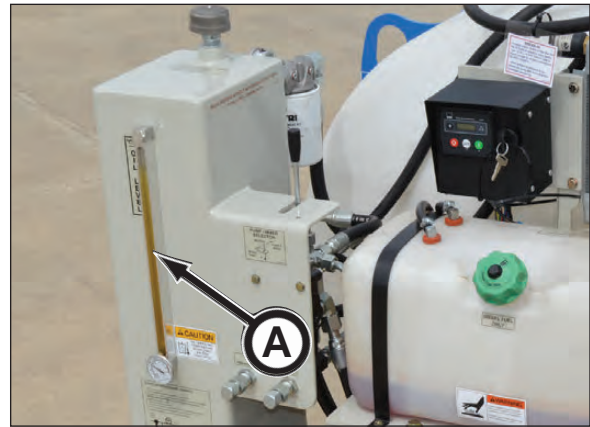

13. CHECK HYDRAULIC RETURN FILTER INDICATOR

To prevent over or under servicing of the hydraulic return filter, a filter indicator (B) has been installed on the return filter housing.

The green OK zone indicates that the filter is functioning properly.

The yellow zone indicates that the filter will soon require replacement.

When the needle on the gauge is in the red CHANGE zone, replace filter as soon as possible to prevent engine damage using the following procedure:

1. Clean and dry area around return filter.
2. Remove filter. Dispose of oil and filter properly.

NOTICE Remove filter gasket if stuck in filter housing.

3. Fill new filter with clean hydraulic oil (refer to Section 8, Fuels & Lubricants for oil specification).
4. Lubricate new filter gasket with a light coating of clean hydraulic oil.
5. Install new filter. Hand tighten only.
6. Start engine and run at low idle until the hydraulic system is warm. Then check for leaks.
7. Shut down engine.
8. Check hydraulic tank oil level on gauge (C). Add hydraulic oil, if necessary.

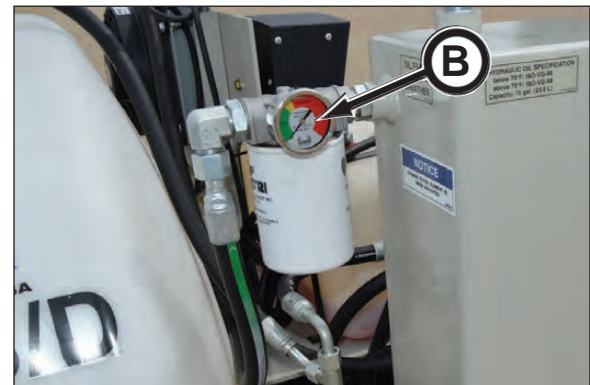

14. INSPECT COVERS & GUARDS

Inspect all guards and covers to be sure they are properly mounted in place, and undamaged. Repair or replace as needed. NEVER operate without covers or guards in place.



15. INSPECT VALVES AND LEVERS

Inspect valves and levers for proper operation.
Repair or replace as needed.



16. INSPECT WIRING & CABLES

Inspect wiring and cable for cracking, fraying or other damage. Replace as needed.



17. INSPECT WATER/SOLUTION TANK

Inspect water tank for damage. Repair or replace as needed.



18. FLUSH WATER/SOLUTION TANK

The water/solution tank must be flushed with clean water if:

- the solution will be sitting idle more than an overnight period. Check the directions on the polymer or bentonite bag/container for additional instructions.
- the solution will be sitting idle overnight in freezing weather. The tank will also require draining or adding a RV anti-freeze solution. (refer to Cold Weather Protection in section 6, Operation.



19. INSPECT OUTLET TUBE & PRESSURE & RETURN HOSES

Inspect outlet tube, pressure and return hoses and all hydraulic hoses for cracks, wear or damage. Replace as needed.



20. INSPECT DECALS

Visually inspect all decals so they are clean and readable. Replace decals if they are damaged, missing, or hard to read.

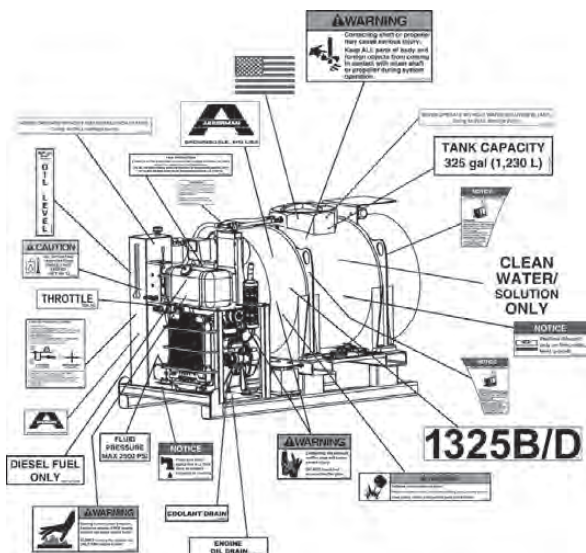

FIRST 50 HOURS OF OPERATION & EVERY 100 HOURS THEREAFTER

NOTICE

Refer to your engine operator's manual for additional maintenance information.

21. CHANGE ENGINE OIL & FILTER

1. Start the engine and run to operating temperature.
2. Stop the engine.



3. Clean area around the fill cap. Remove cap. This will allow oil to drain more quickly.



4. Clean area around engine oil drain plug (A).
5. Position a properly sized container to collect waste oil.
6. Remove drain plug and drain oil into container. Recycle oil properly.
7. Replace drain plug.

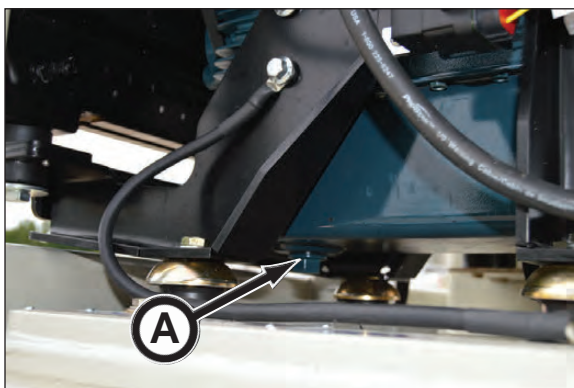

8. Clean area around oil filter (B).
9. Remove oil filter and clean filter mounting pad. Dispose of filter properly.

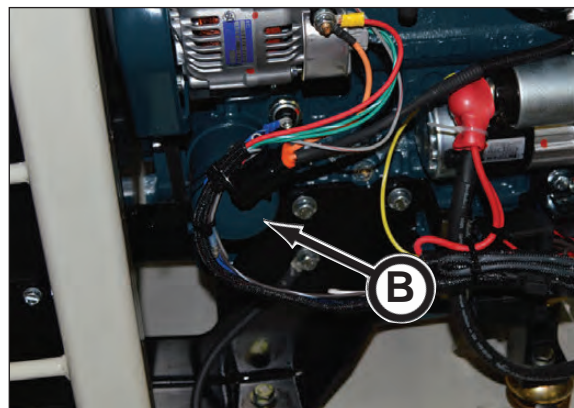

(Continued on next page)

10. Lubricate gasket on new filter with clean oil.
11. Install new filter and hand tighten according to values printed on the filter. Do not overtighten the filter element.
12. Fill engine with SAE 15W40 engine oil or other oils specified in the Fuels & Lubricants section. The following fluid capacity is an approximate value. Be sure to check level after filling. DO NOT OVERFILL.

Oil Capacity approx. 4 qt (3.79 L)

13. Install fill cap. Clean up spills.
14. Start engine and run until warm for 5 minutes and check for leaks.
15. After the engine is warm, shut engine off and let it sit for 10 minutes.
16. Recheck the engine oil level on dipstick and fill as needed. Oil level should be within the marks on the dipstick. Do not overfill!

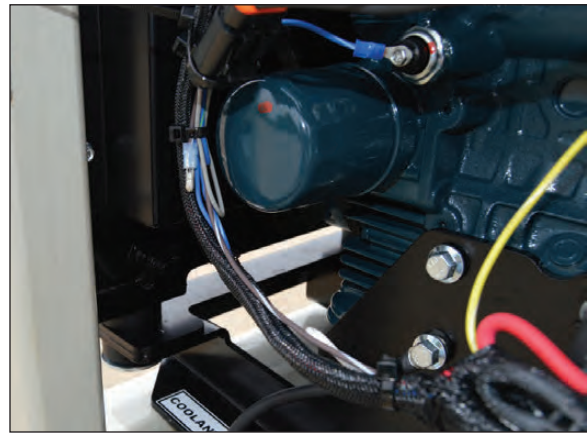

22. CHECK ENGINE FAN BELT TENSION

NOTICE

Refer to your engine manual for more information.

IMPORTANT: If operating engine with a loose or damaged belt, and if the fan is damaged, overheating or insufficient charging may result.

Check engine fan belt for cracking, fraying or wear. Replace belt as needed.

Check the fan belt deflection and adjust as follows:

1. Depress the belt down with your thumb (a force of approximately 22 ft lbs (98 N•m) or use a belt tension gauge at location (A) between the pulleys. The belt deflection should be 0.28 - 0.35 (7 - 9 mm).
2. Adjust the fan belt tension if necessary. Loosen the alternator set bolt (B) and pivot bolt (C). Carefully move the alternator with a pry bar (between engine block and alternator) or other device to tighten the belt to the proper deflection. If belt is damaged, it must be replaced with new.
3. Tighten bolt(s).
4. Replace all guards.

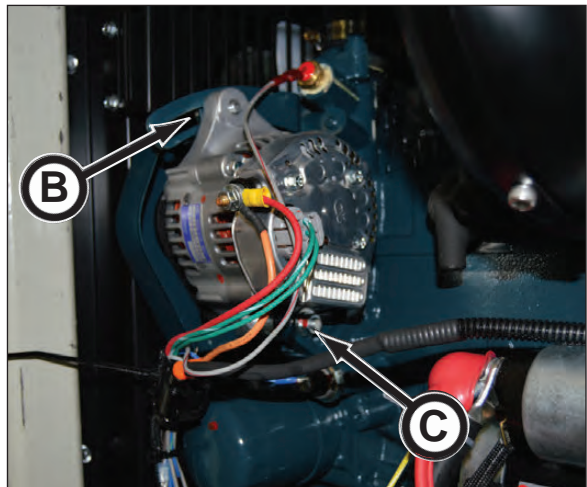
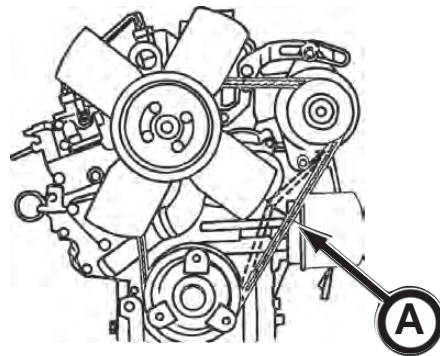

WEEKLY OR EVERY 50 HOURS OF OPERATION

NOTICE

Refer to your engine operator's manual for additional maintenance information.

23. CHECK RADIATOR & OIL COOLER FINS

Check and clean radiator and oil cooler fins.

CAUTION When using compressed air, always wear eye protection to prevent injury to eyes.

Use compressed air (maximum 28 psi) to remove dirt, dust and debris from radiator and oil cooler fins. If there is a large amount of debris on the fins, use a mild soap to thoroughly clean fins and then rinse with water.



24. CHECK BATTERY

WARNING Batteries produce explosive gases.

Wear eye protection and protective clothing during battery service.

Keep sparks, flames, and cigarettes away from batteries.

Contact with battery acid can cause severe burns. Flush immediately and thoroughly with clean water. Get medical attention immediately.

Charge a battery only in a well-ventilated area.

Never charge a frozen battery.

Visually check the battery for damage. If damaged replace with new.

Check battery cables for damage or fraying. If damaged, replace with new.

Be sure cables are secured properly to the battery posts and engine mounts.

Inspect battery mount and battery box for damage. If damaged or if parts are missing, replace with new.



EVERY 100 HOURS OF OPERATION

NOTICE

Refer to your engine owner's manual for additional maintenance information.

215. CHANGE ENGINE OIL & FILTER

1. Start the engine and run to operating temperature.
2. Stop the engine.
3. Clean area around the fill cap. Remove cap. This will allow oil to drain more quickly.
4. Clean area around engine oil drain plug (A).
5. Position a properly sized container to collect waste oil.
6. Remove drain plug and drain oil into container. Recycle oil properly.
7. Replace drain plug.
8. Clean area around oil filter (B).
9. Remove oil filter and clean filter mounting pad. Dispose of filter properly.

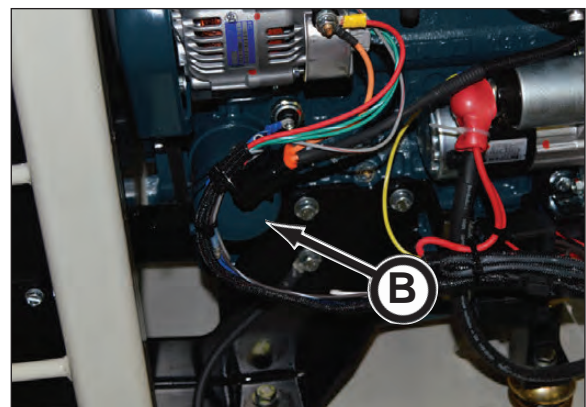
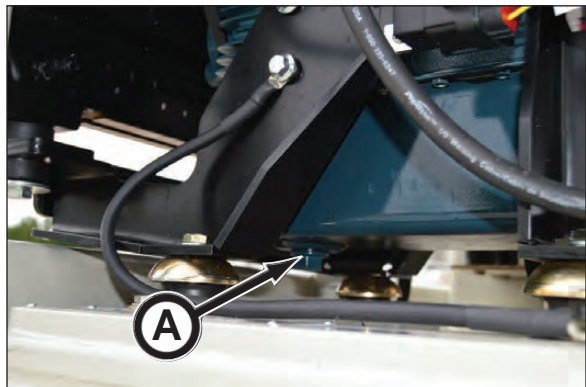
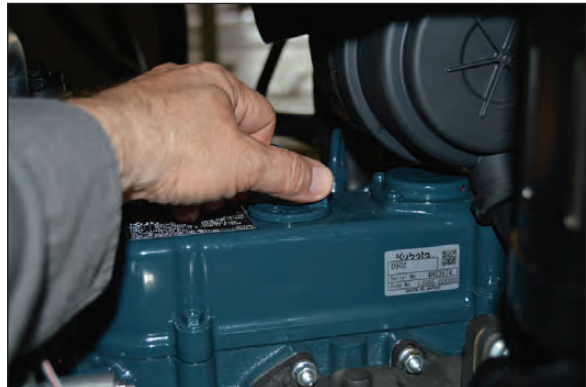
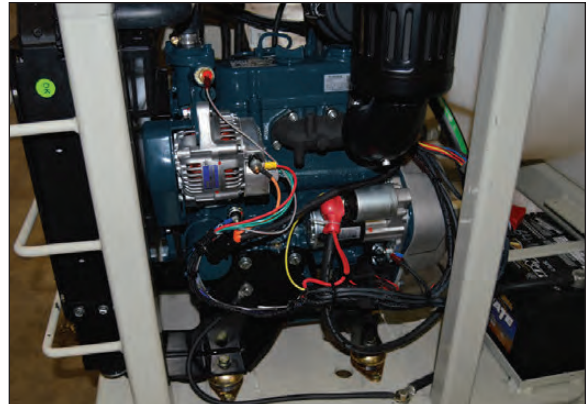

(Continued on next page)

10. Lubricate gasket on new filter with clean oil.
11. Install new filter and hand tighten according to values printed on the filter. Do not overtighten the filter element.
12. Fill engine with SAE 15W40 engine oil or other oils specified in the Fuels & Lubricants section. The following fluid capacity is an approximate value. Be sure to check level after filling. DO NOT OVERFILL.

Oil Capacity approx. 4 qt (3.79 L)

13. Install fill cap. Clean up spills.
14. Start engine and run until warm for 5 minutes and check for leaks.
15. After the engine is warm, shut engine off and let it sit for 10 minutes.
16. Recheck the engine oil level on dipstick and fill as needed. Oil level should be within the marks on the dipstick. Do not overfill!

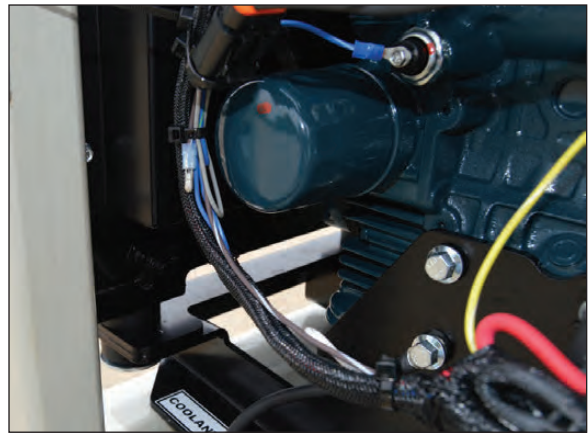

26. CLEAN AIR CLEANER ELEMENT

NOTICE

Refer to your engine manual for more information.

IMPORTANT: Be sure cover latch clips are properly secured. If the cover is loose, dust and dirt will be sucked in, wearing down the engine cylinder liner and piston ring, thereby resulting in poor power output.

Periodically check air cleaner element for dirt and dust buildup. The engine performance efficiency is drastically affected with a clogged air cleaner element.

1. Clean area around the air cleaner assembly.
2. Squeeze air cleaner dust unloader valve on air cleaner assembly to release any trapped dirt particles. If the sealing top of the valve is damaged, life of the air filter element will be greatly reduced.



3. Unlatch cover clips and remove cover.



4. Gently remove element. Bumping the element against air cleaner housing may contaminate the clean side of the filter housing with dirt and dust.

5. Thoroughly clean the inside of the filter housing with a clean, damp cloth. Dirt left in the filter housing will shorten the life of the filter element. Be sure the housing is dry before reinstalling the element.

6. If dry dust adheres to the air cleaner element, use compressed air (maximum 30 psi) from the inside while turning the element to remove the dust. If dirt cannot be removed from element, replace with new.



7. Carefully install a new or cleaned filter element by applying pressure by hand at outer rim of filter.



8. Reinstall the air cleaner cover properly. Be sure the cover TOP and arrow markings is installed at the top of the housing.

9. Secure the cover to the housing by latching the cover clips.



27. CLEAN FUEL FILTER ELEMENT

Clean the fuel filter element as follows:

1. Shut off engine.
2. Move the fuel lever (A) to the OFF position.
3. Remove the screw ring (B).
4. Carefully remove the filter bowl (C).
5. Pour out the fuel from the bowl.
6. Rinse the bowl with fresh diesel fuel.
7. Remove fuel filter element (D) and rinse with fresh diesel fuel.
8. After cleaning fuel filter element, replace the element into filter head assembly (E). Be sure oring (F) and spring (G) are properly seated into element.
9. Replace bowl into fuel head assembly. Be sure the o-ring (H) is properly seated into the head assembly before reinstalling the bowl.
10. Tighten the bowl to the head assembly using the screw ring.
11. The fuel system requires bleeding. An appropriate sized catch pan will be required to collect fuel during the bleeding process.
12. Move the fuel lever (I) to the ON position.
13. Loosen air vent plug (J) of the head assembly a few turns.
14. Retighten the plug when only fuel is visible, no bubbles.
15. If needed, open the air vent plug (not shown) on top of the fuel injection pump.
16. Retighten the plug when only fuel is visible, no bubbles.
17. Start engine and check for leaks.

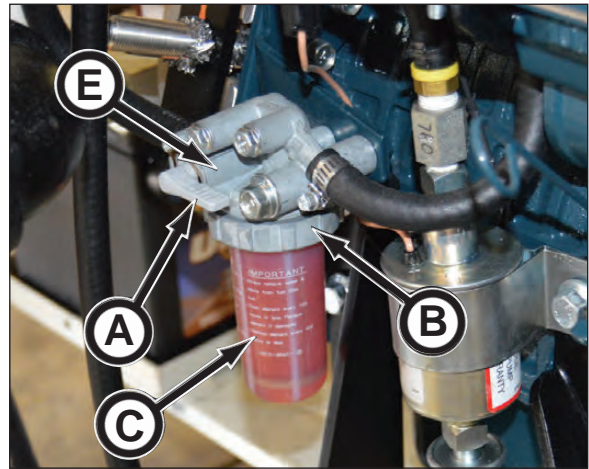

Engine Fuel Lever Shown in OFF Position

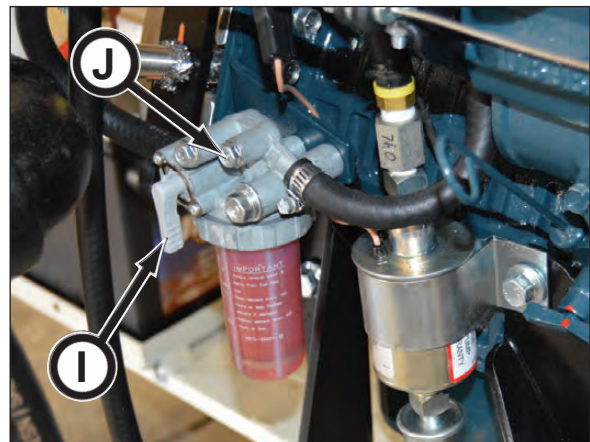
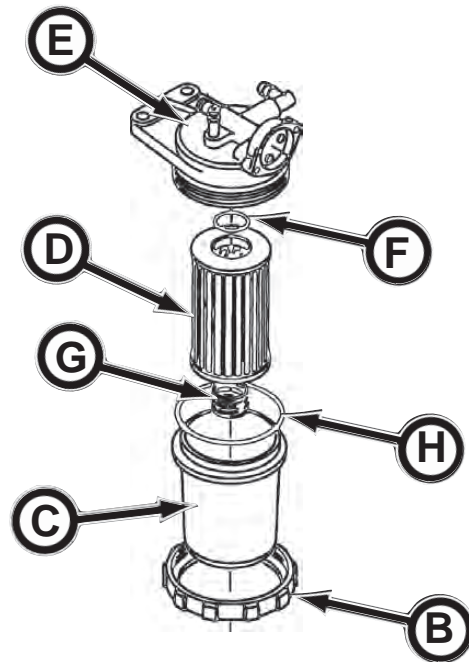

Engine Fuel Lever Shown in ON Position

28. CHECK ENGINE FAN BELT TENSION

NOTICE Refer to your engine manual for more information.

IMPORTANT: If operating engine with a loose or damaged belt, and if the fan is damaged, overheating or insufficient charging may result.

Check engine fan belt for cracking, fraying or wear. Replace belt as needed.

Check the fan belt deflection and adjust as follows:

1. Depress the belt down with your thumb (a force of approximately 22 ft lbs (98 N•m) or use a belt tension gauge at location (A) between the pulleys. The belt deflection should be 0.28 - 0.35 (7 - 9 mm).
2. Adjust the fan belt tension if necessary. Loosen the alternator set bolt (B) and pivot bolt (C). Carefully move the alternator with a pry bar (between engine block and alternator) or other device to tighten the belt to the proper deflection. If belt is damaged, it must be replaced with new.
3. Tighten bolts.
4. Replace all guards.

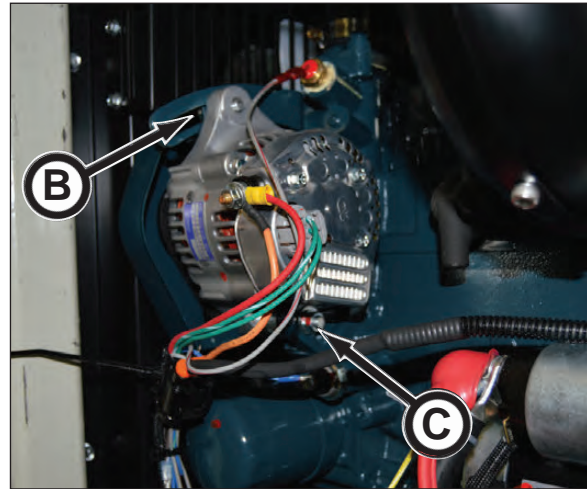
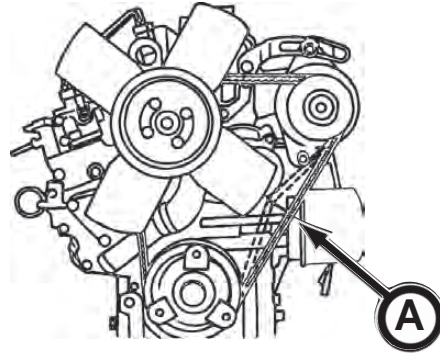

MONTHLY OR EVERY 200 HOURS OF OPERATION

NOTICE

Refer to your engine operation manual for additional maintenance information.

29. INSPECT ENGINE MOUNTS

Visually inspect engine mounts (A) for loose hardware or damaged parts.

Tighten all loose hardware and replace defective parts.

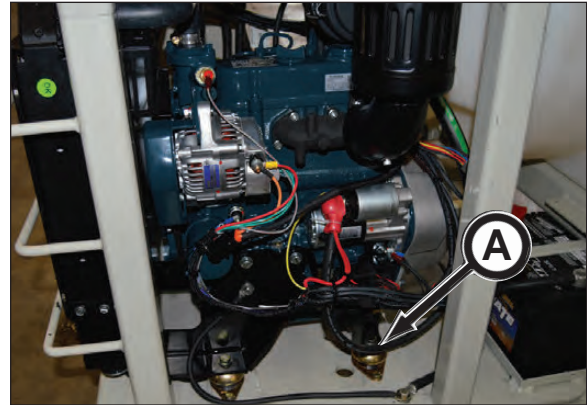

30. INSPECT PUMP MOUNTING BOLTS

Visually inspect pump coupler housing (B) mounting bolts for loose hardware or damaged parts.

Tighten all loose hardware and replace defective parts.

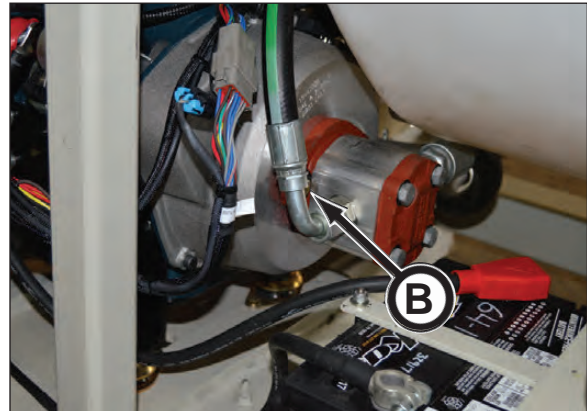

31. INSPECT AIR INTAKE & EXHAUST CONNECTIONS

NOTICE

Refer to your engine operator's manual for additional maintenance information.

Inspect all air intake and exhaust connections. Tighten clamps as needed and replace defective parts.



32. INSPECT & CLEAN FUEL TANK CAP

Inspect cap for damage. If cap is damaged, replace with new.

Remove cap and clean any debris or dirt from cap body.



33. SERVICE ENGINE

Refer to your engine's operator's manual for the maintenance intervals for servicing engine: valve clearance, fuel injection pump, and intake air line replacement.



EVERY 400 HOURS OF OPERATION

34. REPLACE FUEL FILTER ELEMENT

Replace the fuel filter element as follows:

1. Shut off engine.
2. Move the fuel lever (A) to the OFF position.
3. Remove the screw ring (B).
4. Carefully remove the filter bowl (C).
5. Pour out the fuel from the bowl.
6. Rinse the bowl with fresh diesel fuel.
7. Remove fuel filter element (D).
8. Apply a small amount of diesel fuel to the oring of the new fuel filter.
9. Install a new fuel filter element into filter head assembly (E). Be sure oring (F) and spring (G) are properly seated into element.
10. Replace bowl into fuel head assembly. Be sure the o-ring (H) is properly seated into the head assembly before reinstalling the bowl.
11. Tighten the bowl to the head assembly using the screw ring.
12. The fuel system requires bleeding. An appropriate sized catch pan will be required to collect fuel during the bleeding process.
13. Move the fuel lever (I) to the ON position.
14. Loosen air vent plug (J) of the head assembly a few turns.
15. Retighten the plug when only fuel is visible, no bubbles.
16. If needed, open the air vent plug (not shown) on top of the fuel injection pump.
17. Retighten the plug when only fuel is visible, no bubbles.
18. Start engine and check for leaks.

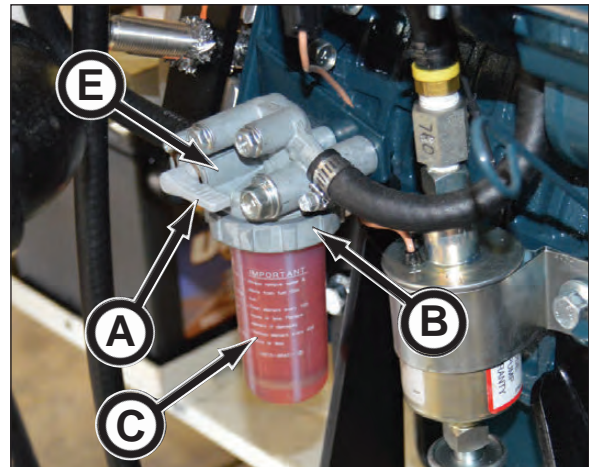

Engine Fuel Lever Shown in OFF Position

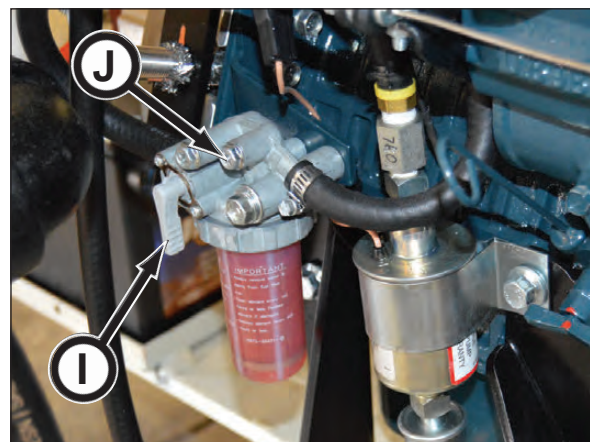
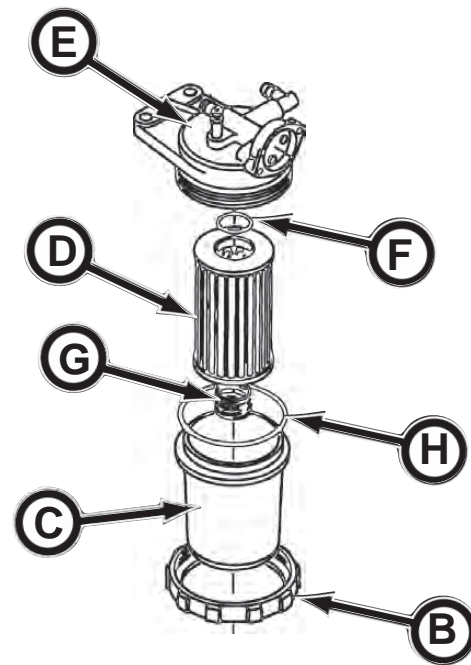

Engine Fuel Lever Shown in ON Position

EVERY 500 HOURS OF OPERATION

NOTICE

Refer to your engine operation manual for additional maintenance information.

35. REPLACE ENGINE FAN BELT

NOTICE

Refer to your engine manual for more information.

Replace fan belt as follows:

1. Loosen alternator set bolt (A) and pivot bolt (B).
2. Carefully remove belt. Guards may need to be removed for easier belt removal and installation. Guards **MUST** be replaced before engine is running.
3. Carefully install new belt on the engine pulleys and alternator pulley.
4. Set the belt deflection as follows:
 - Depress the belt down with your thumb (a force of approximately 22 ft lbs (98 N•m) or use a belt tension gauge at location (A) between the pulleys. The belt deflection should be 0.28 - 0.35 (7 - 9 mm).
 - Adjust the fan belt tension. Loosen the alternator set bolt (B) and pivot bolt (C). Carefully move the alternator with a pry bar (between engine block and alternator) or other tool to tighten the belt to the proper deflection. If belt is damaged, it must be replaced with new.
5. Tighten bolts.
6. Replace all guards.

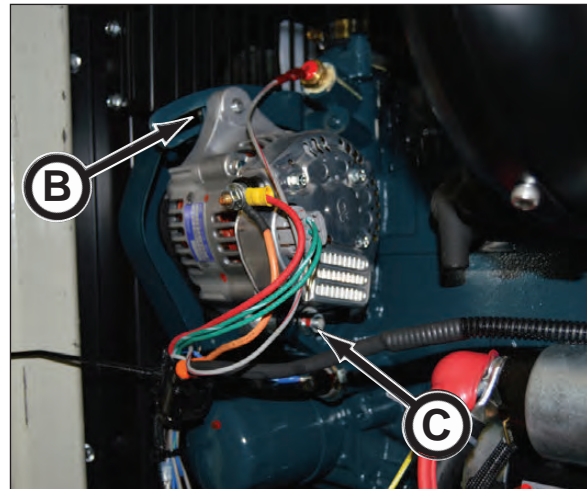
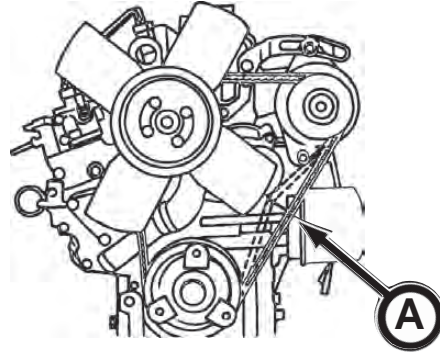

36. REPLACE AIR CLEANER FILTER ELEMENT

Replace the air cleaner element every 500 hours of operation regardless if it is not damaged or dirty.

1. Clean area around the air cleaner assembly and cover.
2. Unlatch the cover clips from the cover and remove cover.



3. Gently remove filter element. Bumping the element against air cleaner housing may contaminate the clean side of the filter housing with dirt and dust.
4. Properly dispose of the filter element.
5. Thoroughly clean the inside of the filter housing with a clean, damp cloth. Dirt left in the filter housing will shorten the life of the filter element. Be sure the housing is dry before installing the new element.



6. Carefully install a new filter element by applying pressure by hand at outer rim of filter.



7. Secure the cover to the housing by latching the cover clips. Be sure the cover TOP and arrow markings is installed at the top of the housing.



37. CHECK COOLING SYSTEM

⚠ WARNING

Cooling system under pressure. Explosive release of HOT engine coolant can cause severe burns. SLOWLY remove the radiator cap ONLY if the engine is cool.

1. Visually check the cooling system for leaks. Tighten all clamps securely.
2. Check to be sure the coolant level is at the bottom of the filler neck. Add coolant mixture if needed. Refer to Engine Coolant in the Fuels & Lubricants section of this manual.
3. Inspect all cooling system hoses. If the hoses are found to be in a hard, weak, or cracked condition, replace the hose(s).
4. Check the radiator for bent fins. Carefully straighten fins.
5. Check the inlet and outlet tubes for cracks, kinks, dents, or fractured seams. Repairs must be made by a qualified radiator technician.
6. Check the effectiveness of the coolant solution. Refer to your engine operation manual for more information.

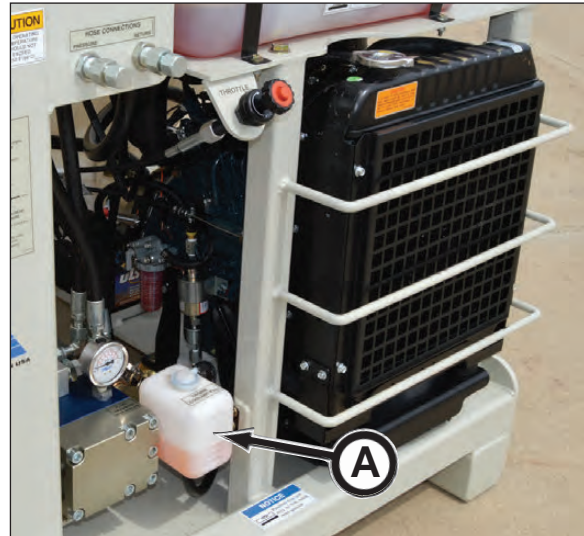

38. DRAIN & FILL HYDRAULIC TANK

1. Remove drain plug (A) and drain oil into a properly sized catch pan.
2. Replace drain plug.
3. Properly dispose of used oil.

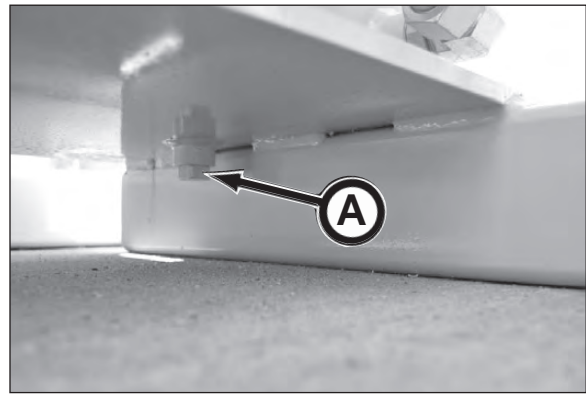

4. Remove oil fill cap.
5. Fill tank with approximately 15 gal. (57 L) of ISO-VG-68 Premium AW Hydraulic Oil or refer to Hydraulic Tank in the Fuels & Lubricants section for more information.
6. Replace fill cap.
7. Check oil level with oil level gauge (D).

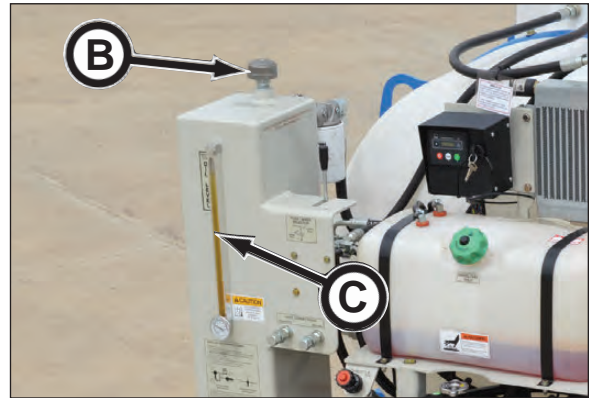

EVERY 1000 HOURS OF OPERATION

NOTICE

Refer to your engine operation manual for additional maintenance information.

39. FLUSH & FILL COOLING SYSTEM

WARNING

Cooling system under pressure. Explosive release of HOT engine coolant can cause severe burns. SLOWLY remove the radiator cap ONLY if the engine is cool.



1. Wear gloves and eye protection before attempting to drain the cooling system.
2. With the engine cool, SLOWLY remove the radiator cap (A).



3. Open radiator drain valve (B) AND engine block drain valve (C). Drain all coolant into catch pan. Dispose of coolant properly.

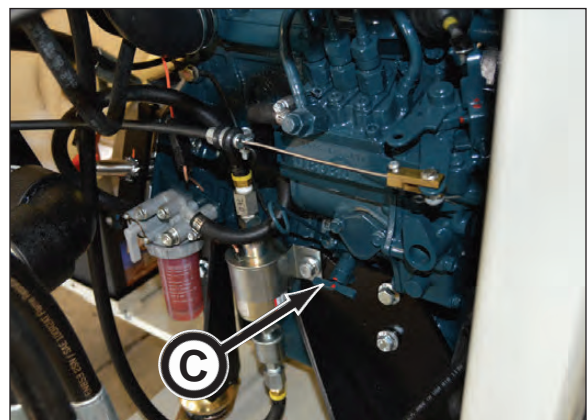
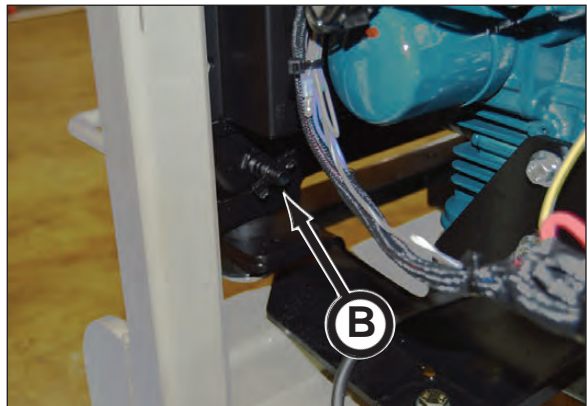

(Continued on next page)

4. Remove the overflow hose (A) of the radiator pressure cap and drain coolant from the engine coolant reservoir (B) in catch pan. Dispose of coolant properly.
5. After draining the coolant, flush the radiator and engine block to remove any rust, scale and contaminants.



5. Close the radiator drain valve (C) AND engine drain valve (D).
6. Reinstall overflow hose of the radiator pressure cap.

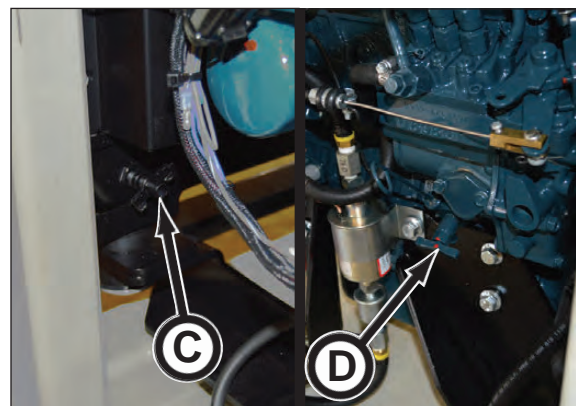

7. Fill coolant (refer to Engine Coolant in the Fuels & Lubricants section) into radiator until coolant level reaches the bottom of the filler neck.
8. Replace radiator cap (E).
9. Start engine and operate it for 5 minutes to circulate the water/coolant mixture.
10. Shut off engine.
11. Once engine has cooled, SLOWLY remove radiator cap.
12. Check radiator coolant level and fill as needed for coolant to reach the bottom of the filler neck.
13. Replace radiator cap.
14. Fill coolant in the engine coolant reservoir. (B). DO NOT fill coolant over the FULL level mark.
14. Start engine and run it until it reaches operating temperature. This will mix the coolant uniformly and circulate it throughout the system.
15. Shut off engine. Check coolant level and add if necessary. Check entire coolant system for leaks.

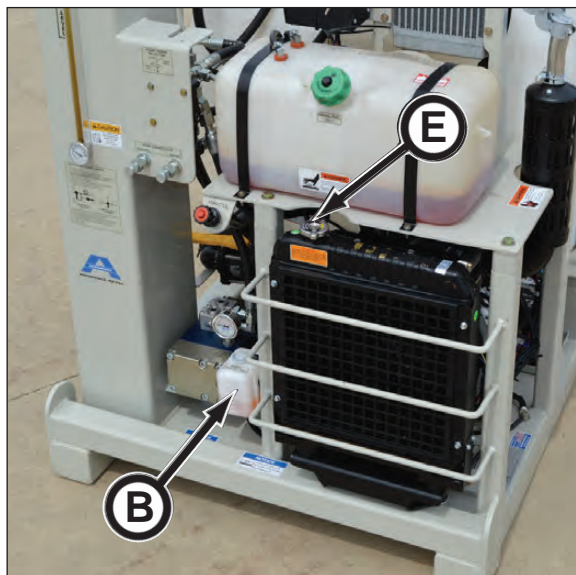

EVERY 2000 HOURS OR EVERY 2 YEARS OF OPERATION

NOTICE

Refer to your engine operation manual for additional maintenance information.

40. REPLACE FUEL SYSTEM & COOLING SYSTEM HOSES

Regularly check the fuel system and engine coolant system hoses. If they are cracked or degraded, replace them. Replace the hoses at least every two years.

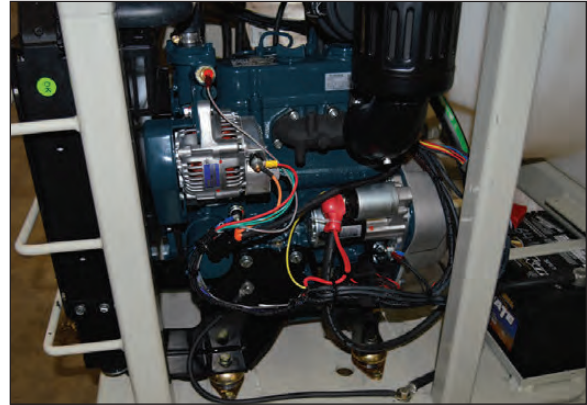

AFTER EACH DRIVE

41. FLUSH & CLEAN WATER/SOLUTION TANK

After each drive, the 1325B/D Bentonite & Lubrication Pump must be flushed and cleaned, and then either drained completely or add RV anti-freeze to the water system so the pump will be ready for the next drive.

1. Flush and clean water system by using clean water to flush the tank and water system components until the water is clear and free of sediment. Failure to do so will result in clogging of the fluid in the tank, hoses and/or components. Refer to Cleaning Tank in section 6, Operation for more information.
2. Once tank and water system is clean, completely drain system or add RV anti-freeze to the water system. Refer to Cold Weather Protection in section 6, Operation for more information.



Storage

PREPARING FOR STORAGE

1. Repair worn or damaged parts.
2. Wash all equipment and tank thoroughly.
3. Drain tank. Flush and drain pump and all fluid lines including to prevent clogging or freezing during storage. Be sure to also remove and clean tank strainer.
4. Drain engine oil and refill engine with oil specified in Fuels & Lubrication section. Dispose of oil properly.
5. Drain water and sediment from fuel system. Be sure to bleed system properly.
6. Add proper engine fuel stabilizer for a full tank. Be sure fuel tank is filled completely.
7. Store diesel fuel in plastic, aluminum or steel containers specially coated for diesel fuel storage.
8. Clean air cleaner.
9. Restart engine and operate machine long enough to warm the oil. Check for leaks after machine warms up.
10. Loosen engine belt.
11. Remove battery (negative cable first) and store it in a cool, dry place. Remove corrosion from cables and battery case. Use baking soda to neutralize acid. Place battery on wood (not concrete) and connect a small trickle charger to it to maintain charge; or charge battery every 30 days it is in storage, if necessary.
12. Repaint equipment where necessary.
13. Drain hydraulic oil, flush oil reservoir, change hydraulic filter, and refill hydraulic tank. Check for leaks.
14. Wipe up lube spills. Dispose of rags and trash properly.
15. Store equipment in a clean, dry, ventilated location.
16. If the engine to be stored for a long period of time, refer to your engine operator's manual.
17. Clean and drain lubrication hoses. Store indoors to minimize UV damage.

REMOVING FROM STORAGE

1. Clean equipment thoroughly.
2. Check to make sure all decals are clean and readable.
3. Check condition of wires and cables. Repair or replace as necessary.
4. Charge battery and install it.
5. Check coolant level. If coolant is low, check for leaks and add coolant as required.
6. Adjust engine fan belt tension.
7. Check for leaks. Repair or replace as necessary.
8. Check hydraulic oil level. If fluid is low, check for leaks and add oil as required. Also, check condition of the oil; be sure there is no water in the oil.
9. Check hydraulic return filter indicator. Replace filter as needed per indicator.
10. Check tank strainer. Clean as needed. If damaged, replace with new.
11. Check condition of all hoses and connections. Tighten, repair or replace with new as needed.
12. Before operating, cycle hydraulic functions several times to purge air from hydraulic system.
13. Check oil levels in hydraulic tank and engine crankcase. Add oil if necessary (refer to section 8, Fuels & Lubricants for oil specifications).
14. Fill tank with clean water/solution.
15. If diesel fuel is stored for more than a month prior to use, or there is a slow turnover in fuel tank or supply tank, add a fuel conditioner or equivalent to stabilize the fuel and prevent water condensation. Refer to your engine manual for more information.
16. Refer to your engine operator's manual on how to restore engine to service.
17. Review this Operation Manual.

Troubleshooting

NOTICE

For additional engine troubleshooting information, refer to your engine operator's manual.

Problem	Cause	Solution
Engine does not start.	Fuel shutoff is in the OFF position.	Move fuel shutoff in ON position.
	No fuel or improper fuel in fuel tank.	Fill fuel tank.
	Selector valve not in neutral position.	Move selector to neutral position.
	Low oil level.	Add oil to engine crankcase.
	Engine overloaded.	Release load.
	Dirty air cleaner.	Replace air cleaner.
	If engine still does not start, contact your Akkerman Aftermarket Support Representative.	
Pump cannot reach maximum pressure.	Pump shaft control in bypass mode.	Reset to lubrication/jetting/washer mode.
	Relief valve is not set properly.	Adjust relief to 2500 psi max.
	If max. pressure still cannot be reached, contact your Akkerman Aftermarket Support Representative.	
Lubrication pump is pulsating.	Air in water supply.	Add more water/solution in tank and check pump inlet connections.
	Dirty tank strainer.	Clean tank strainer.
	Outlet cam lock is not engaged.	Be sure cam lock is fully engaged.
	Hydraulic oil level is low.	Fill hydraulic oil tank as needed.
	If pump continues to pulsate, contact your Akkerman Aftermarket Support Representative.	
No water discharge out of pump.	No water in tank.	Fill tank.
	Selector is in neutral or mixer position.	Move selector to Pump position.
	Ball valve on tank closed.	Open tank ball valve.
	Strainer plugged.	Clean strainer.
	Inlet hose damaged.	Replace hose.
	Air lock between tank and strainer.	Release air lock by loosening strainer until fluid flows.
	If no water still does not discharge out of pump, contact your Akkerman Aftermarket Support Representative.	
Mixer not functioning.	Selector valve is in neutral position.	Move selector to Mixing position.
	Mixer control is in Off position.	Move control to Mixer On position.
	Hydraulic oil level is low.	Fill hydraulic oil tank as needed.
	If mixer is still not functioning contact your Akkerman Aftermarket Support Representative.	

ENGINE FAULT CONDITION ICONS

NOTICE

For additional engine information, refer to your engine operator's manual.

When the alarm indicator (A) illuminates, the fault condition icon will be displayed in the main status display. The icon with description is shown below:

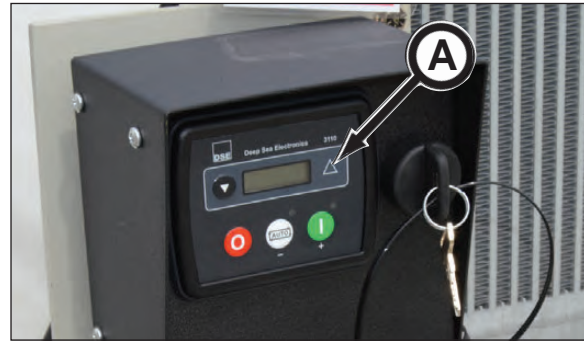

ICON	DESCRIPTION	
	AUXILIARY INPUTS	Auxiliary inputs can be user configured and will display the message as written by the user.
	FAIL TO START	The engine has not fired after the preset number of start attempts
	FAIL TO STOP	The module has detected a condition that indicates that the engine is running when it has been instructed to stop.
<div style="border: 1px solid black; padding: 5px;"> NOTE:- 'Fail to Stop' could indicate a faulty oil pressure sensor - If engine is at rest check oil sensor wiring and configuration. </div>		
	LOW OIL PRESSURE	The module detects that the engine oil pressure has fallen below the low oil pressure pre-alarm setting level after the <i>Safety On</i> timer has expired.
	ENGINE HIGH TEMPERATURE	The module detects that the engine coolant temperature has exceeded the high engine temperature pre-alarm setting level after the <i>Safety On</i> timer has expired.
	UNDERSPEED	The engine speed has fallen below the underspeed pre alarm setting
	OVERSPEED	The engine speed has risen above the overspeed pre alarm setting
	CHARGE FAILURE	The auxiliary charge alternator voltage is low as measured from the W/L terminal.
	LOW FUEL LEVEL	The level detected by the fuel level sensor is below the low fuel level setting.
	BATTERY UNDER VOLTAGE / BATTERY OVER VOLTAGE	The DC supply has fallen below or risen above the low/high volts setting level.
	GENERATOR UNDER VOLTAGE	The generator output voltage has fallen below the pre-set pre-alarm setting after the <i>Safety On</i> timer has expired.
	GENERATOR OVER VOLTAGE	The generator output voltage has risen above the pre-set pre-alarm setting.
	GENERATOR UNDER FREQUENCY	The generator output frequency has fallen below the pre-set pre-alarm setting after the <i>Safety On</i> timer has expired.
	GENERATOR OVER FREQUENCY	The generator output frequency has risen above the pre-set pre-alarm setting.
	CAN ECU WARNING CAN ECU SHUTDOWN	The engine ECU has detected an alarm – CHECK ENGINE LIGHT Contact Engine Manufacturer for support.
	CAN DATA FAIL	The module is configured for CAN operation and does not detect data on the engine Can datalink.
	EMERGENCY STOP	The emergency stop button has been depressed. This a failsafe (normally closed to battery positive) input and will immediately stop the set should the signal be removed. Removal of the battery positive supply from the emergency stop input will also remove DC supply from the Fuel and Start outputs of the controller.
<div style="border: 1px solid black; padding: 5px;"> NOTE:- The Emergency Stop Positive signal must be present otherwise the unit will shutdown. </div>		
	MAGNETIC PICKUP FAILURE	Pulses are no longer being detected from the magnetic pickup probe (3110-xxx-01 magnetic pickup version only)
	INTERNAL MEMORY ERROR	Either the configuration file or engine file memory is corrupted. Contact your supplier for assistance.

TORQUE CHART

Use these torque values as a guideline when tightening hardware unless otherwise specified in this manual.

Lubricated Coarse UNC Threads Grade 8 Fasteners			Lubricated Fine UNF Threads Grade 8 Fasteners		
Bolt Size	Torque		Bolt Size	Torque	
	ft. lbs.	(N·m)		ft. lbs.	(N·m)
1/4 - 20	10	(14)	1/4 - 28	11	(15)
5/16 - 18	20	(27)	5/16 - 24	22	(30)
3/8 - 16	35	(47)	3/8 - 24	39	(53)
7/16 - 14	56	(76)	7/16 - 20	62	(84)
1/2 - 13	85	(115)	1/2 - 20	96	(130)
9/16 - 12	123	(167)	9/16 - 18	137	(186)
5/8 - 11	170	(231)	5/8 - 18	192	(260)
3/4 - 10	301	(408)	3/4 - 16	336	(456)
7/8 - 9	450	(610)	7/8 - 14	500	(678)
1 - 8	680	(922)	1 - 12	740	(1003)
1-1/8 - 7	960	(1302)	1-1/8 - 12	1030	(1397)
1-1/4 - 7	1360	(1844)	1-1/4 - 12	1500	(2034)
1-1/2 - 6	2360	(3200)	1-1/2 - 12	2660	(3607)

Identification Numbers

Model and serial numbers are required when ordering parts or requesting service information. Record your model and serial numbers below.

1325B/D BENTONITE & LUBRICATION PUMP

Model Number _____

Serial Number _____

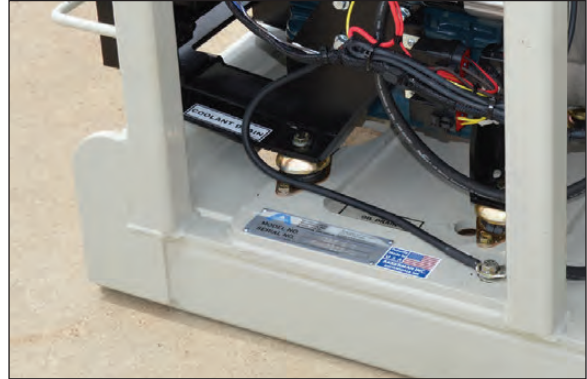

NOTES

Safety Data Sheets

The Federal Occupational, Safety, and Health Administration (OSHA) Standard 29 CFR 1910.1200, require that specific safety data sheets (SDS) be available to employees before operating this equipment. This may include information on substances contained in this equipment such as fuel and gear lubricant.

Akkerman Inc. will provide, at no cost, SDS which apply to its product line. Simply contact your Akkerman Aftermarket Support representative for a copy.

To ensure a prompt response to your SDS request, include your return address (including zip or postal code) and the equipment's model numbers and serial numbers with your request.

NOTES

Warranty

Akkerman Inc. warrants that all equipment manufactured by it be free from defects due to workmanship or material under normal use and service for a period of 90 days. This warranty does not apply to normal wear items such as cutter teeth, filters, etc. Akkerman Inc. does not warrant the fitness of its equipment for a particular purpose or application.

Warranty

NOTES

Parts

Contents

Introduction	16-2
Decals	16-4
Left View	16-4
Right View	16-6
Jetting & Lubrication Pump Shaft Control	16-8
1325B/D Parts	16-10
Bentonite & Lubrication Pump Assembly, 1325B/D, FA48850F	16-10
Hydraulic & Water Assembly, 1325B, A48865A	16-12
Fitting Kit, A49061A	16-14
Hose Kit, A49060A	16-15
Jetting & Lubrication Shaft Control, A43749A	16-16
Operator Controls	16-17
Engine, 14 HP, P0125-146.....	16-18

INTRODUCTION

This parts manual contains assembly illustrations of the Akkerman 1325B/D Bentonite & Lubrication Pump. The illustrations in this manual are intended to show typical construction of various parts. In some instances, the details of parts illustrated may not exactly represent their actual appearance, but will help to identify parts performing the same functions.

LOCATING PARTS

This parts manual is organized to help you locate parts information quickly. An Alphabetical Index, Section 17, is provided to determine the page number of the assembly a part is used. If the part number is known, the Numerical Index, Section 18, can also be utilized to find the page number of the assembly.

USE GENUINE AKKERMAN PARTS

The use of second-rate parts could affect the efficient performance of the Bentonite & Lubrication Pump. ALWAYS use genuine Akkerman parts.

PARTS ORDERING

To order fast, accurate, and reliable parts service, call (800) 533-0386, (507) 567-2261, or fax (507) 567-2720, and provide the following information.

1. Model Number
2. Serial Number
3. Part Number, Description, and Quantity
4. Shipping Preference

MEASUREMENTS

The unit of measure in this manual is in inches unless indicated otherwise.

HARDWARE SPECIFICATION

All Akkerman products are assembled with SAE Grade 8 bolts, nuts, and washers. ALWAYS use matched fastener hardware when replacing or repairing the unit.

If you find any errors with this manual or have any suggestions for improvement, please let us know. Email your comments via the Akkerman web site (Contact Us web page), or mail your suggestions to: Akkerman Inc, ATTN: Technical Publications, 58256 266th Street, Brownsdale, MN 55918.

Akkerman Inc. reserves the right to improve its product without notice or obligation.

NOTES

1325B/D BENTONITE & LUBRICATION PUMP DECALS - LEFT VIEW
1325B/D

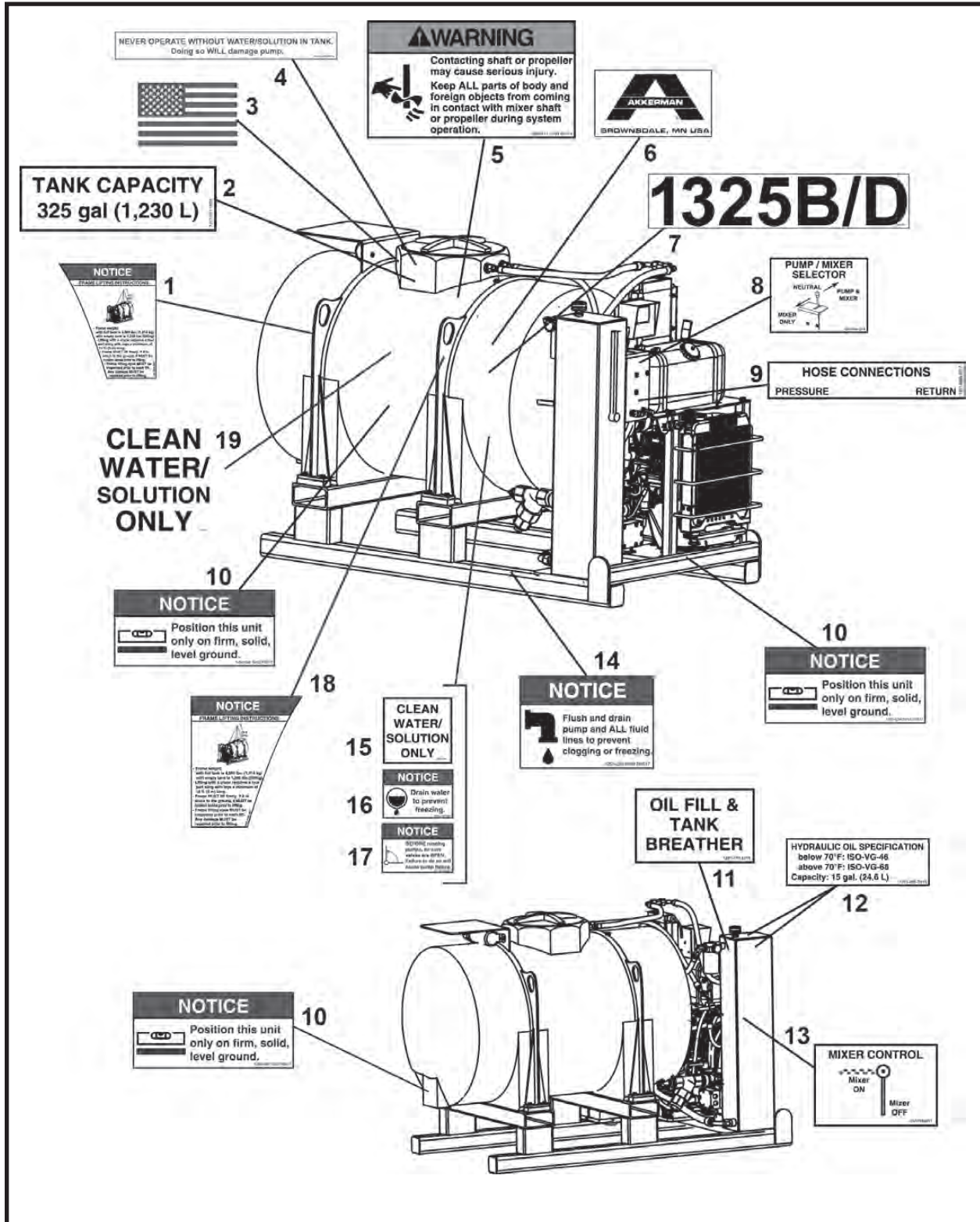

ITEM	QTY	PART NO.	DESCRIPTION
1	1	1251-762R	DECAL, Notice Lifting Instructions - Right
2	1	1251-221	DECAL, Tank Capacity 325 gal
3	1	1250-558	DECAL, USA Flag Small
4	1	1251-677	DECAL, Never Operate Without Water/Solution

1325B/D BENTONITE & LUBRICATION PUMP DECALS - LEFT VIEW
1325B/D

ITEM	QTY	PART NO.	DESCRIPTION
5	1	1250-311	DECAL, Warning Contact With Mixer
6	1	1251-246	DECAL, Akkerman, Large
7	1	1251-757	DECAL, Model 1325B/D
8	1	1251-686a	DECAL, Pump/Mixer Selector
9	1	1251-680b	DECAL, Hose Connections
10	3	1250-638	DECAL, Notice Position Level Ground
11	1	1251-710	DECAL, Oil Fill & Tank Breather
12	2	1251-685	DECAL, Hydraulic Oil Specification
13	1	1251-753	DECAL, Mixer Control
14	1	1251-228	DECAL, Notice Flush Pump & Lines
15	1	1251-679	DECAL, Clean Water/Solution Only
16	1	A3000-1	DECAL, Notice Drain Water
17	1	1251-023	DECAL, Notice Open Valves
18	1	1251-762L	DECAL, Notice Lifting Instructions - Left
19	1	1251-678	DECAL, Clean Water/Solution Only

1325B/D BENTONITE & LUBRICATION PUMP DECALS - RIGHT VIEW
1325B/D

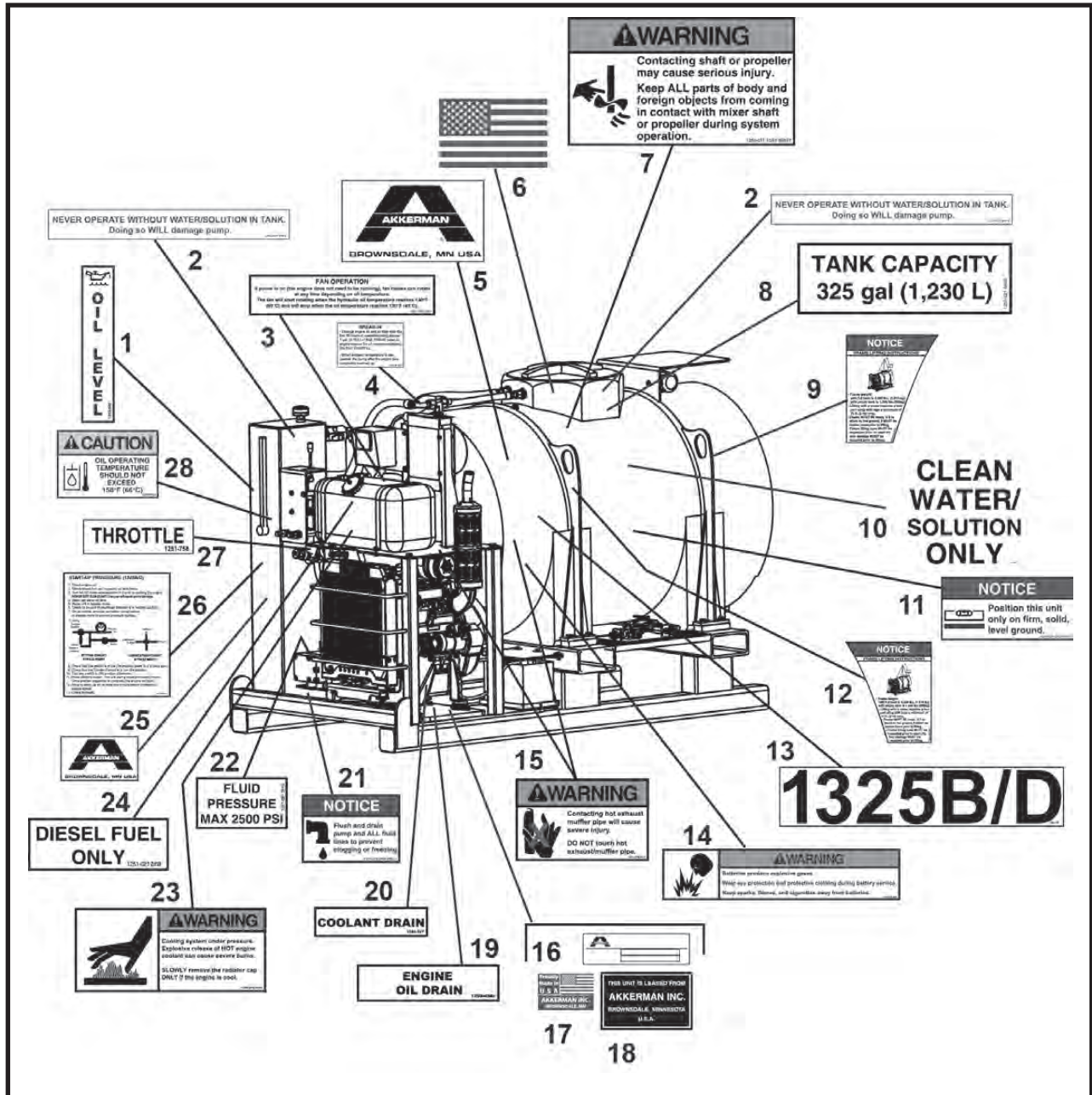

ITEM	QTY	PART NO.	DESCRIPTION
1	1	1250-649	DECAL, Oil Level
2	2	1251-677	DECAL, Never Operate Without Water/Solution
3	1	1251-763	DECAL, Fan Operation
4	1	1251-761	DECAL, Break-In
5	1	1251-246	DECAL, Akkerman, Large
6	1	1250-558	DECAL, USA Flag Small
7	1	1250-311	DECAL, Warning Contact With Mixer
8	1	1251-221	DECAL, Tank Capacity 325 gal
9	1	1251-762L	DECAL, Notice Lifting Instructions - Left
10	1	1251-678	DECAL, Clean Water/Solution Only
11	1	1250-638	DECAL, Notice Position Level Ground
12	1	1251-762R	DECAL, Notice Lifting Instructions - Right

1325B/D BENTONITE & LUBRICATION PUMP DECALS - RIGHT VIEW
1325B/D

ITEM	QTY	PART NO.	DESCRIPTION
13	1	1251-757	DECAL, Model 1325B/D
14	1	1251-016	DECAL, Warning Battery Explosive
15	1	1251-759	DECAL, Warning, Hot Muffler
16	1	REF	PLATE, Serial Number
17	1	1250-544	DECAL, Made in USA
18	1	1250-098	DECAL, Lease (Used on Leased Equipment)
19	1	1250-498c	DECAL, Engine Oil Drain
20	1	1251-527	DECAL, Coolant Drain
21	1	1251-228	DECAL, Notice Flush and Drain Pump
22	1	1251-681	DECAL, Fluid Pressure 2500 PSI
23	1	1250-697	DECAL, Warning, Cooling System
24	1	1251-021	DECL, Diesel Fuel Only
25	1	1251-247	DECAL, Akkerman, Medium
26	1	1251-760	DECAL, Start-Up Procedure
27	1	1251-758	DECAL, Throttle
28	1	1250-483	DECAL, Oil Operating Temperature

JETTING & LUBRICATION PUMP SHAFT CONTROL DECALS

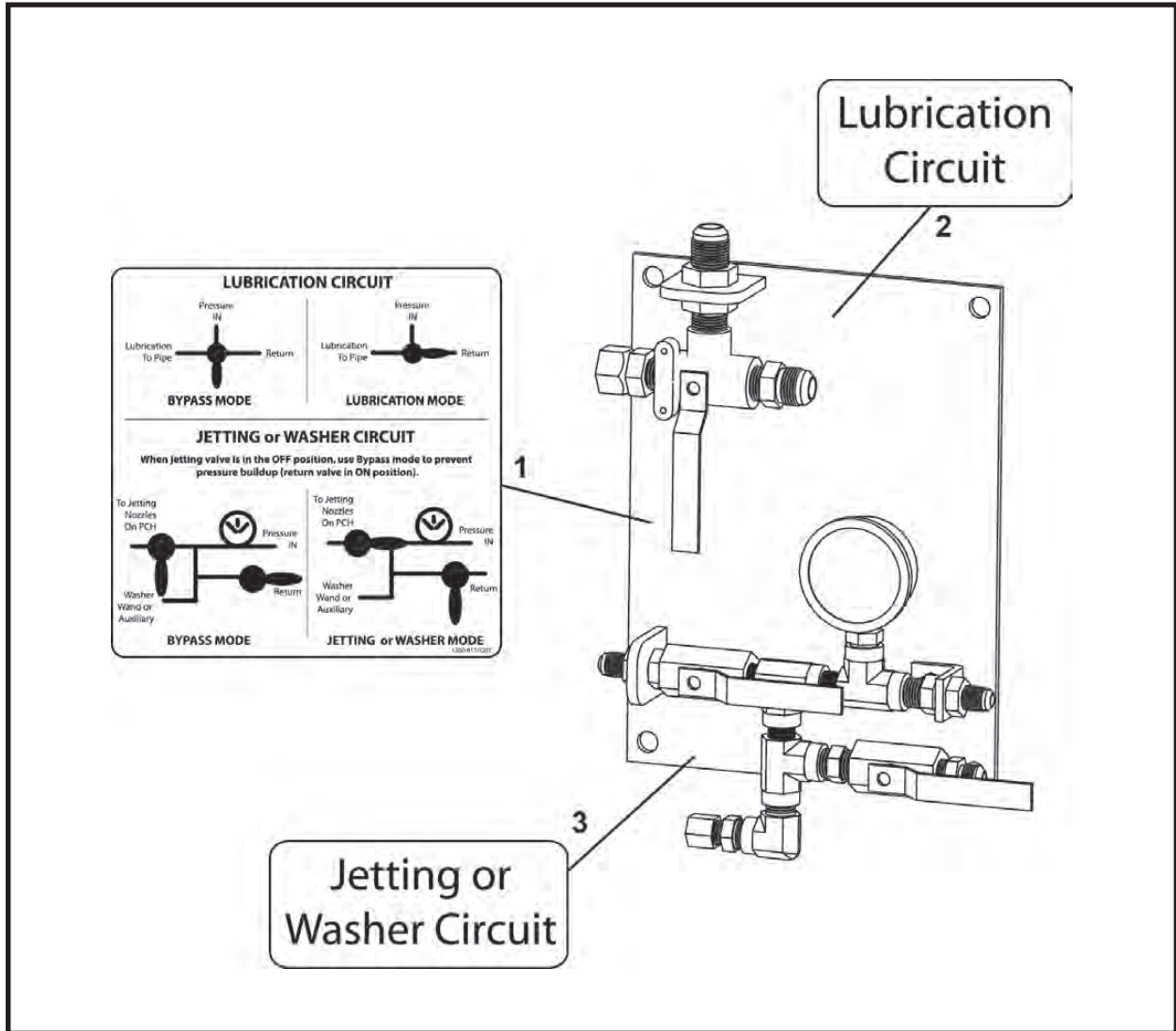

ITEM	QTY	PART NO.	DESCRIPTION
1	1	1250-917a	DECAL, Lubrication-Jetting-Washer Control
2	1	1250-917b	DECAL, Lubrication Circuit
3	1	1250-917c	DECAL, Jetting Or Washer Circuit

NOTES

1325B/D BENTONITE & LUBRICATION PUMP ASSEMBLY, FA48850F

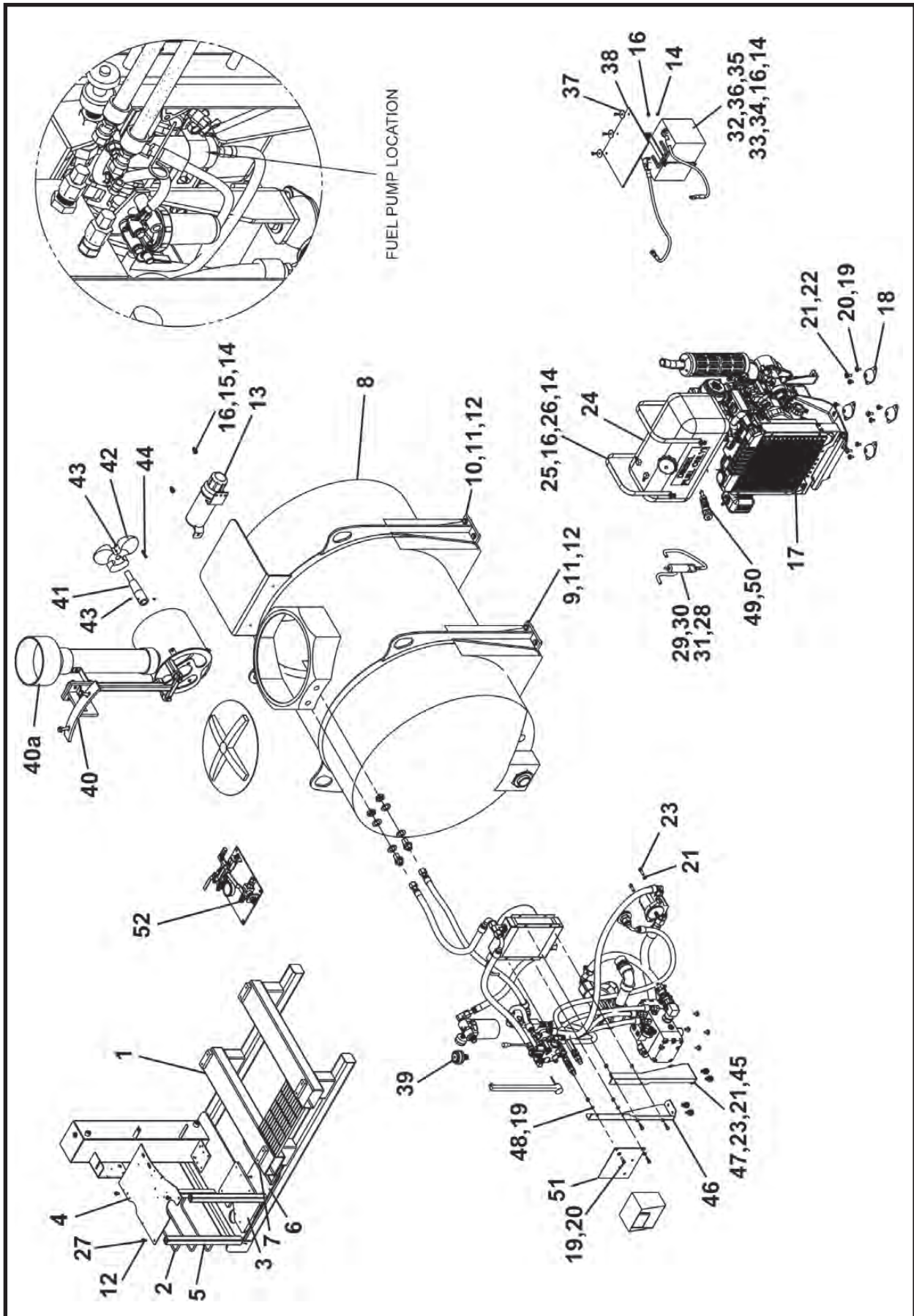

1325B/D BENTONITE & LUBRICATION PUMP ASSEMBLY, FA48850F

ITEM	QTY	PART NO.	DESCRIPTION
0	1	FA48850F	1325B/D BENTONITE & LUBRICATION PUMP
1	1	A08270A	SKID, Pump
2	3	A48856P	GUARD, Radiator
3	1	A48851P	MOUNT, Engine
4	1	A49059A	PLATE, Fuel Tank
5	3	A48854A	SUPPORT, Tank
6	1	A48356P	TRAY, Battery
7	1	A48862P	MOUNT, Battery Flap
8	1	A48401P	TANK, 325 Gallon
9	1	A47891A	LIFT EYE
10	1	A08283A	SHELF
11	8	P0001-08-005	BOLT, Hex 1/2 UNC x 1.25
12	11	P0040-008	WASHER, Hardened Flat 1/2
13	1	P0095-128	TUBE, Document
14	11	P0013-04-000	NUT, Nyloc 1/4
15	5	P0001-04-004	BOLT, Hex 1/4 UNC x 1
16	17	P0040-004	WASHER, Hardened Flat 1/4
17	1	P0125-163	ENGINE, Diesel
18	1	P0125-163A	ISOLATORS, Vibration
19	16	P0040-005	WASHER, Hardened Flat 5/16
20	12	P0001-05-004	BOLT, Hex 5/16 UNC x 1
21	14	P0040-006	WASHER, Hardened Flat 3/8
22	4	PM10A-1.50-030	BOLT, Hex HD M10 x 1.50 x 30 10.9
23	6	P0001-06-005	BOLT, Hex 3/8 UNC x 1.25
24	1	P0125-161	TANK, Fuel 8 Gallon
25	2	P0125-161A	STRAP, Mounting
26	4	P0001-04-005	BOLT, Hex 1/4 UNC x 1.25
27	3	P0001-08-004	BOLT, Hex 1/2 UNC x 1
29	60 LI	P0201-240	LINE, Fuel 1/4
30	4	P0201-241	CLAMP
30	1	P0125-163C	FUEL PUMP, Electric
31	2	P0220-349	PIPE
32	1	P0064-019	BATTERY
33	2	A44455P	CLAMP, Battery
34	1	012945P00	CLAMP ASSEMBLY
35	1	A40128A	CABLE ASSEMBLY, Positive
36	1	A48598A	CABLE ASSEMBLY, Negative
37	3	P0042-013	WASHER, 1/4 x 9/32 x 1
38	1	A48863P	COVER, Rubber Battery
39*	1	A48865A	HYDRAULIC & WATER ASSEMBLY
40	1	A48826A	ASSEMBLY, Agitator Frame (Includes items 40a-40i)
40a	1	P0258-066	FUNNEL, Hopper
40b^	10	P0040-008	WASHER, Flat 1/2
40c^	4	P0001-08-005	BOLT, Hex 1/2 UNC x 1.25
40d^	2	P0001-08-008	BOLT, Hex 1/2 UNC x 2
40e^	2	P0001-08-012	BOLT, Hex 1/2 UNC x 3
40f^	2	P0013-08A-000	NUT, Nyloc 1/2
40g^	5	P0013-04-000	NUT, Nyloc 1/4
40h^	4	P0020-14-205	SCREW, Truss Head 1/4 UNC x 1
40i^	1	P0001-04-003	BOLT, 1/4 UNC x .75
41	1	A48479P	SHAFT, Agitator
42	1	A48411P	PROPELLER
43	4	P0032-002	SCREW, Socket Set 5/16 x .375
44	1.75 LI	P0047-003	KEY
45	1	A48857A	STAND, Cooler Left
46	1	A48858A	STAND, Cooler Right
47	4	P0013-06A-000	NUT, Nyloc 3/8
48	4	P0013-03.5A-000	NUT, Nyloc 5/16
49	1	P0102-115	CABLE
50	1	P0102-113	WIRE STOP
51	1	A49057P	MOUNT, Panel
52*	1	A43749A	CONTROL, Jetting & Lube Shaft

LI - Linear Inch

* Refer to this section for parts information.

^ Not Shown

1325B/D HYDRAULIC & WATER ASSEMBLY, A48865A

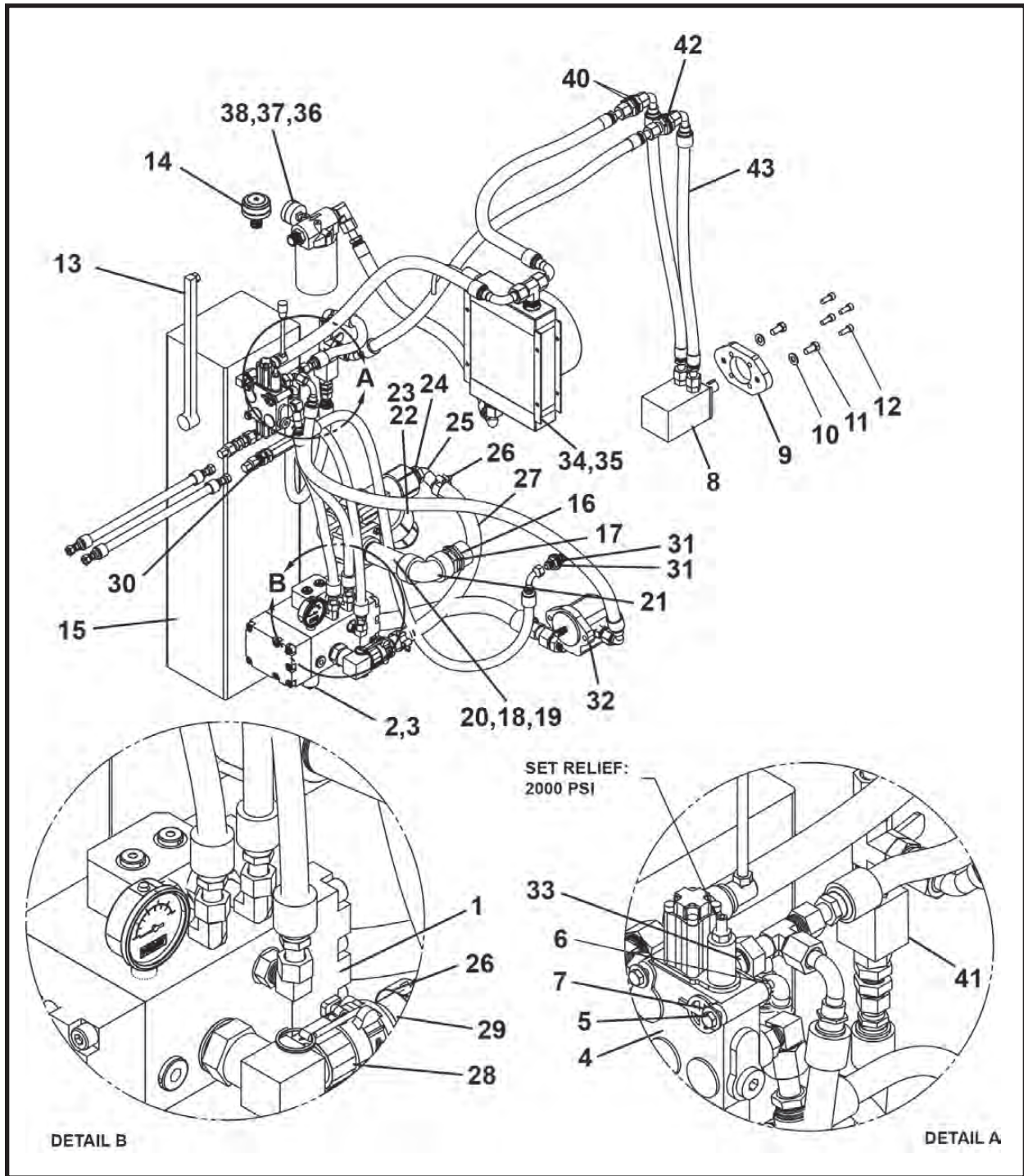

ITEM	QTY	PART NO.	DESCRIPTION
0	1	A48865A	HYDRAULIC & WATER ASSEMBLY
1	1	P0303-396	PUMP, Bentonite (Includes items 1a - 1b)
1a	1	P0303-396A	KIT, Seal
1b	1	P0303-396B	KIT, Water Valve
2	4	P0040-005	WASHER, Hardened Flat 5/16
3	4	PM08A-1.25-016	BOLT, Hex 8 x 1.25 x 16 10.9
4	1	P0302-696	VALVE (Includes item 4a)
4a	1	P0302-696A	CARTRIDGE, Valve
5	3	P0001-04-010	BOLT, Hex 1/4 UNC x 2.5
6	3	P0003-04-000	NUT, 1/4 UNC

1325B/D HYDRAULIC & WATER ASSEMBLY, A48865A

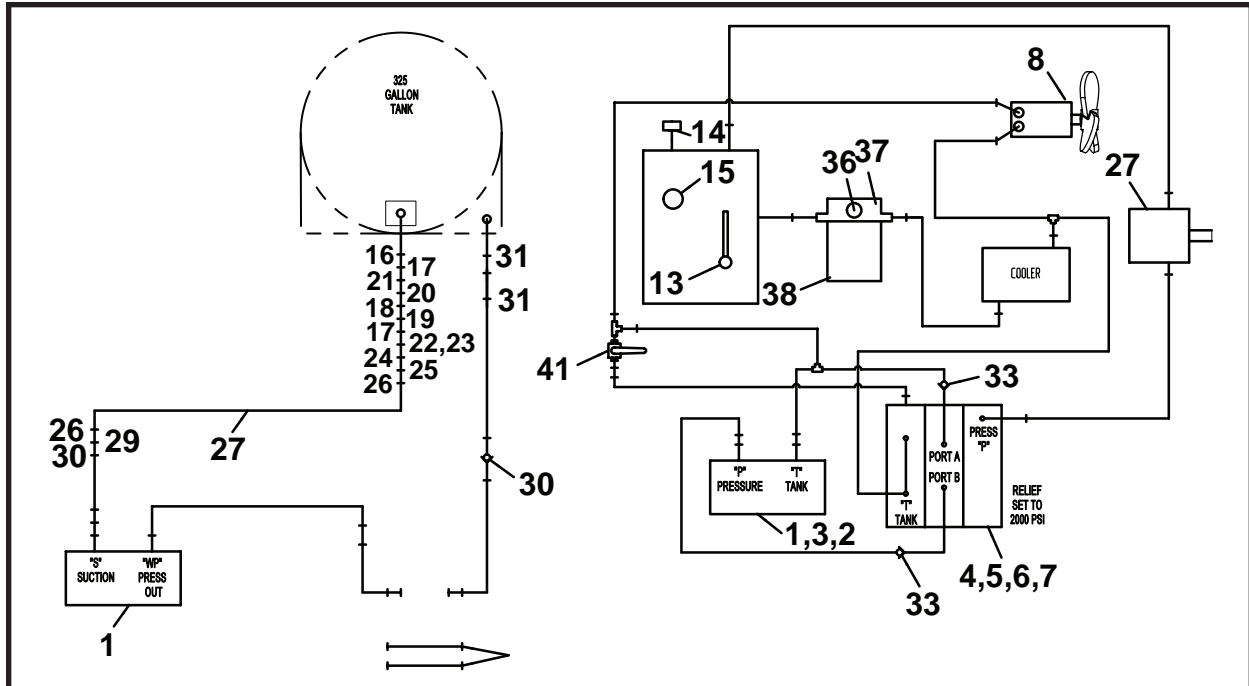

ITEM	QTY	PART NO.	DESCRIPTION
7	3	P0040-004	WASHER, Hardened Flat 1/4
8	1	P0304-347	MOTOR
9	1	A48899P	ADAPTER, Motor
10	2	P0040-008	WASHER Hardened Flat 1/2
11	2	P0001-08-004	BOLT, Hex 1/2 UNC x 1
12	4	P0031-06-004	SCREW, Socket Head Cap 3/8 UNC x 1
13	1	P0301-141	GAUGE, Sight
14	1	P0308-110	BREATHER
15	60 QT	P0126-038	OIL, SAE AW-68 Hydraulic
16	1	P0258-004	REDUCER
17	2	P0258-005	NIPPLE, 1-1/2
18	1	P0258-006	VALVE, 1-1/2
19	1	P0258-018	ELBOW, 1-1/2
20	1	P0258-070	NIPPLE, 1-1/2
21	1	P0258-069	ELBOW, 1-1/2
22	1	P0258-012	STRAINER, Line 1-1/2
19	1	P0251-800	FILTER, Screen
24	1	P0258-013	REDUCER, Bushing
25	1	P0258-015	HOSE, Shank
26	2	P0201-299	CLAMP, Radiator
27	1	P0201-238-024	HOSE, PVC Water Suction
28	1	P0100-122	COUPLER, Cam & Groove
29	1	P0100-121	COUPLER, Cam & Groove
30	1	P0302-102	VALVE, Valve
31	2	P0040-012	WASHER, Hardened Flat 3/4
32	1	P0303-408	PUMP, Gear
33	2	P0302-701	VALVE, Check
34	1	P0125-162	OIL COOLER
35	1	P0093-036A	SWITCH, Temperature 30 AMP
36	1	P0301-105	GAUGE, Filter Indicator
37	1	P0309-217	FILTER HEAD
38	1	P0309-217A	ELEMENT, Filter
39	1	P0201-247	CLAMP, T-Bolt
40	4	P0040-016	WASHER, Hardened Flat 1
41	1	P0302-801	VALVE, Ball
42*	1	A49061A	KIT, Fitting
43*	1	A49060A	KIT, Hose

QT - Quart * Refer to this section for parts information.

HYDRAULIC & WATER FITTING KIT, A49061A

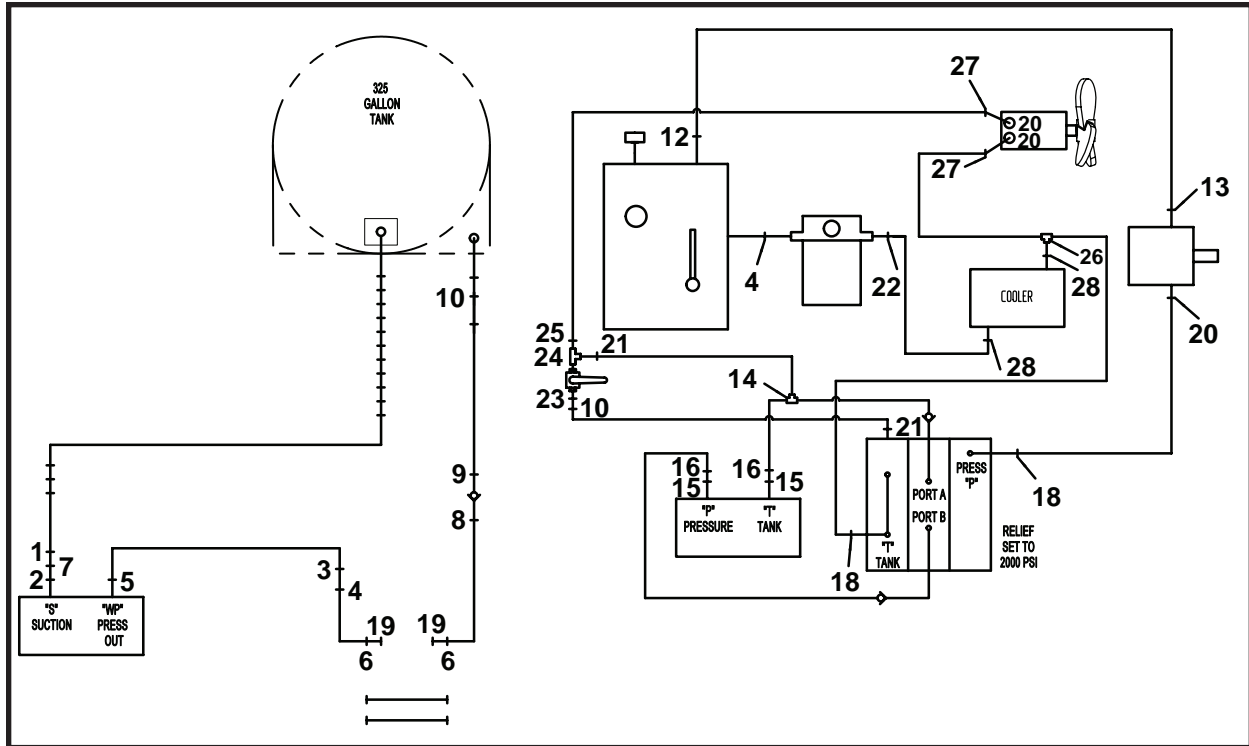

ITEM	QTY	PART NO.	DESCRIPTION
0	1	A49061A	KIT, Fitting
1	1	P0300-057	FITTING, 16MP-16FP90
2	1	P0300-880	FITTING, 16MBSSP
3	1	P0300-873	FITTING, 10FJ-08MJ
4	1	P0300-868	FITTING, 10MJ-10MJBKHD
5	1	P0300-874	FITTING, 08MMFOR-18MM90-NWO
6	2	P0300-147	FITTING, 10FJ-6MJ
7	1	P0300-879	FITTING, 16MBSP-16MP
8	1	P0300-567	FITTING, 10MJ-08MPBKHD
9	1	P0300-053	FITTING, 08MJ-08MP
10	2	P0300-325	FITTING, 8MJ-8MJ
11	1	P0300-060	FITTING, 10MB-PLUG
12	1	P0300-319	FITTING, 16MFS X 16 MORB
13	1	P0300-479	FITTING, 16MFFOR-12MB
14	1	P0300-318	FITTING, 08MFFOR-08FFORX-08MFFOR
15	2	P0300-881	FITTING, 08MFFOR-12MBSPP
16	2	P0300-317	FITTING, 08MFFOR-08FFORX90
17	1	P0300-884	FITTING, 12MB-12MB
18	2	P0300-316	FITTING, 08MFFOR-08MB90
19	2	P0300-126	FITTING, CAP
20	4	P0300-385	FITTING, 10MFS X 10MORB-STR
21	2	P0300-305	FITTING, 08MFFOR-08MB
22	1	P0300-372	FITTING, 12MFFOR-12MB90
23	1	P0300-332	FITTING, 08OR
24	1	P0300-688	FITTING, 08MB-08FB-08FB
25	1	P0300-892	FITTING, 10MFFOR-08MB
26	1	P0300-588	FITTING, FS6602-12-12-12
27	2	P0300-891	FITTING, 10MFFOR-10MFFOR-BKHD
28	2	P0300-886	FITTING, 12MFFOR-16MBSPP

HYDRAULIC & WATER HOSE KIT, A49060A

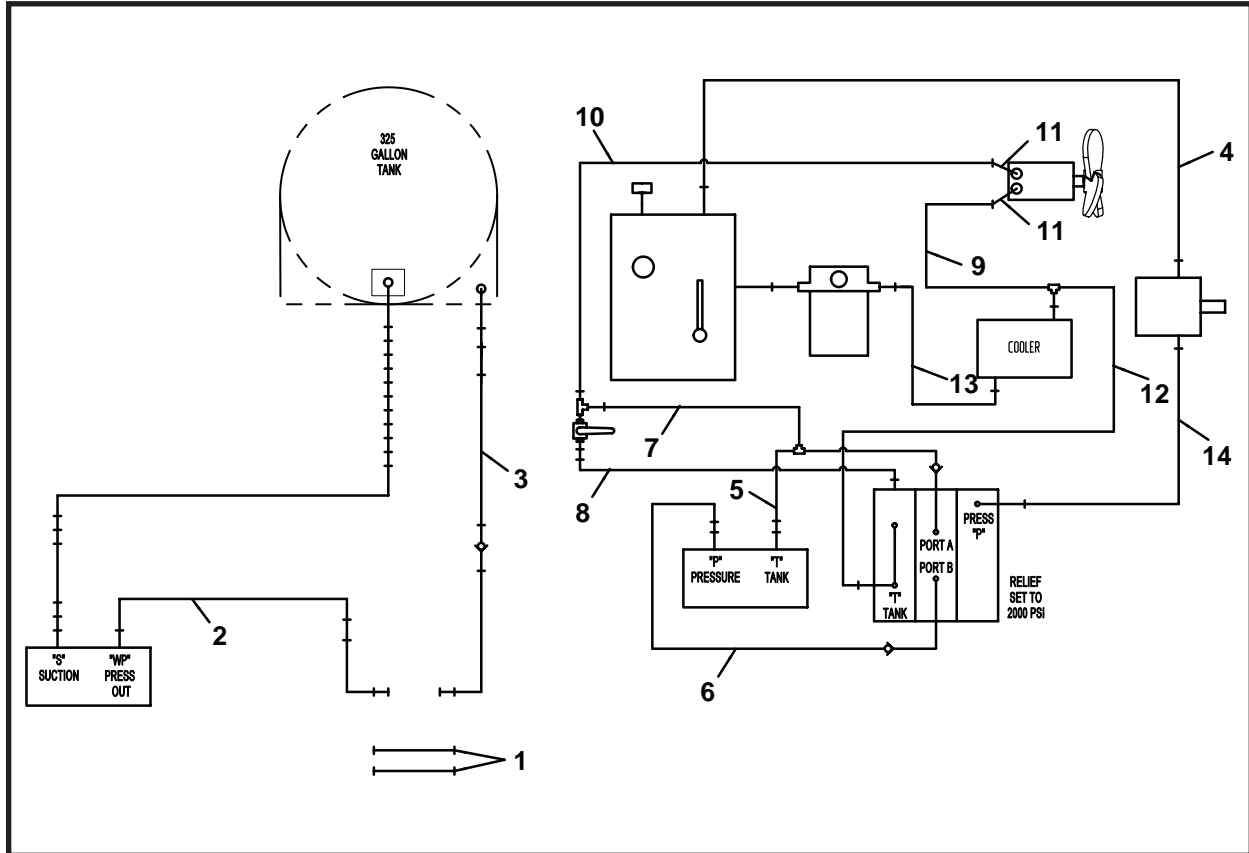

ITEM	QTY	PART NO.	DESCRIPTION
0	1	A49060A	KIT, Hose
1	2	A10311A-018	HOSE ASSEMBLY, 3/8 x 18
2	1	A10368A-028	HOSE ASSEMBLY, 1/2 x 28
3	1	A10361A-045	HOSE ASSEMBLY, 1/2 x 45
4	1	A10342A-023	HOSE ASSEMBLY, 1 x 23
5	1	A10324A-026	HOSE ASSEMBLY, 1/2 x 26
6	1	A10324A-025	HOSE ASSEMBLY, 1/2 x 25
7	1	A10324A-014	HOSE ASSEMBLY, 1/2 x 14
8	1	A10068A-028	HOSE ASSEMBLY, 1/2 x 28
9	1	A09876A-041	HOSE ASSEMBLY, 5/8 x 41
10	1	A09882A-043	HOSE ASSEMBLY, 5/8 x 43
11	2	A09877A-032	HOSE ASSEMBLY, 5/8 x 32
12	1	A09876A-044	HOSE ASSEMBLY, 5/8 x 44
13	1	A09876A-033	HOSE ASSEMBLY, 5/8 x 33
14	1	A09877A-043	HOSE ASSEMBLY, 5/8 x 43

JETTING & LUBRICATION SHAFT CONTROL, A43749A

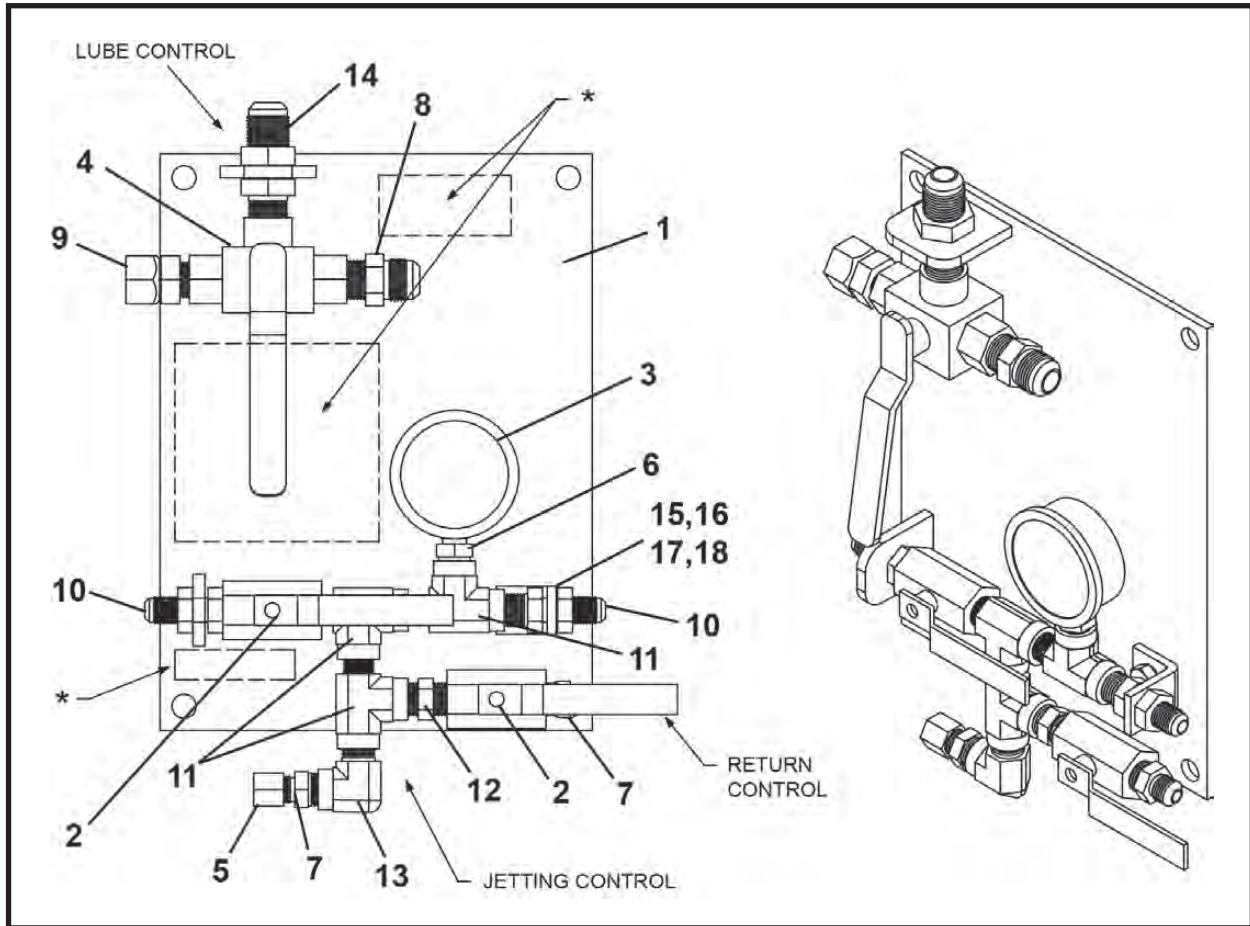

ITEM	QTY	PART NO.	DESCRIPTION
0	1	A43749A	JETTING & LUBRICATION SHAFT CONTROL
1	1	A43757A	MOUNT, Pit Control
2	2	P0302-507	VALVE, Ball 3/8" 2,000 PSI
3	1	P0301-100	GAUGE, Pressure 5000 PSI
4	1	P0302-802	VALVE, Ball 3-Way
5	1	P0300-126	FITTING, 06FJ-CAP
6	1	P0300-093	FITTING, 06MP-04FPS
7	2	P0300-130	FITTING, 06MJ-06MP
8	1	P0300-142	FITTING, 10MJ-08MP
9	1	P0300-399	FITTING, 08MP-10FJX
10	2	P0300-568	FITTING, 6MJ-6MPBKHD
11	3	P0300-569	FITTING, 6MP-6FP-6FP
12	1	P0300-570	FITTING, 6MP-6MP
13	1	P0300-571	FITTING, 6MP-6FP90
14	1	P0300-567	FITTING, 10MJ-8MPKBHD
15	1	A43754P	BRACKET, Pit Control
16	1	P0001-06-004	BOLT, Hex 3/8 UNC x 1
17	1	P0040-006	WASHER, Hardened Flat 3/8
18	1	P0003-06-000	NUT, Hex 3/8 UNC

* Decal 1250-917

OPERATOR CONTROLS

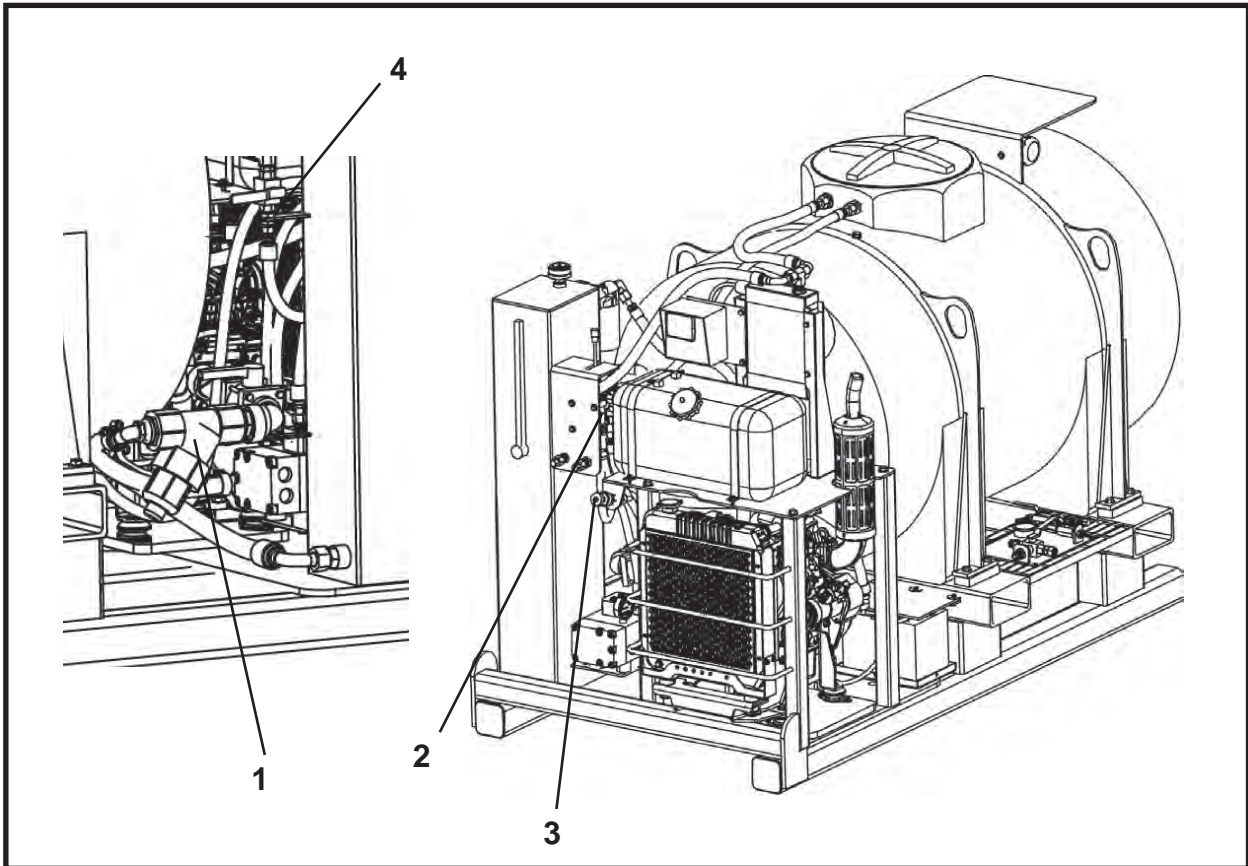

ITEM	QTY	PART NO.	DESCRIPTION
1	1	P0258-006	VALVE, Port 1-1/2
2	1	P0302-696	VALVE, Control (Includes item 2a)
2a	1	P0302-696A	CARTRIDGE, Valve
3	1	P0125-163B	CONTROL, Throttle
4	1	P0302-801	VALVE, Ball

ENGINE, 20.7 HP, P0125-163

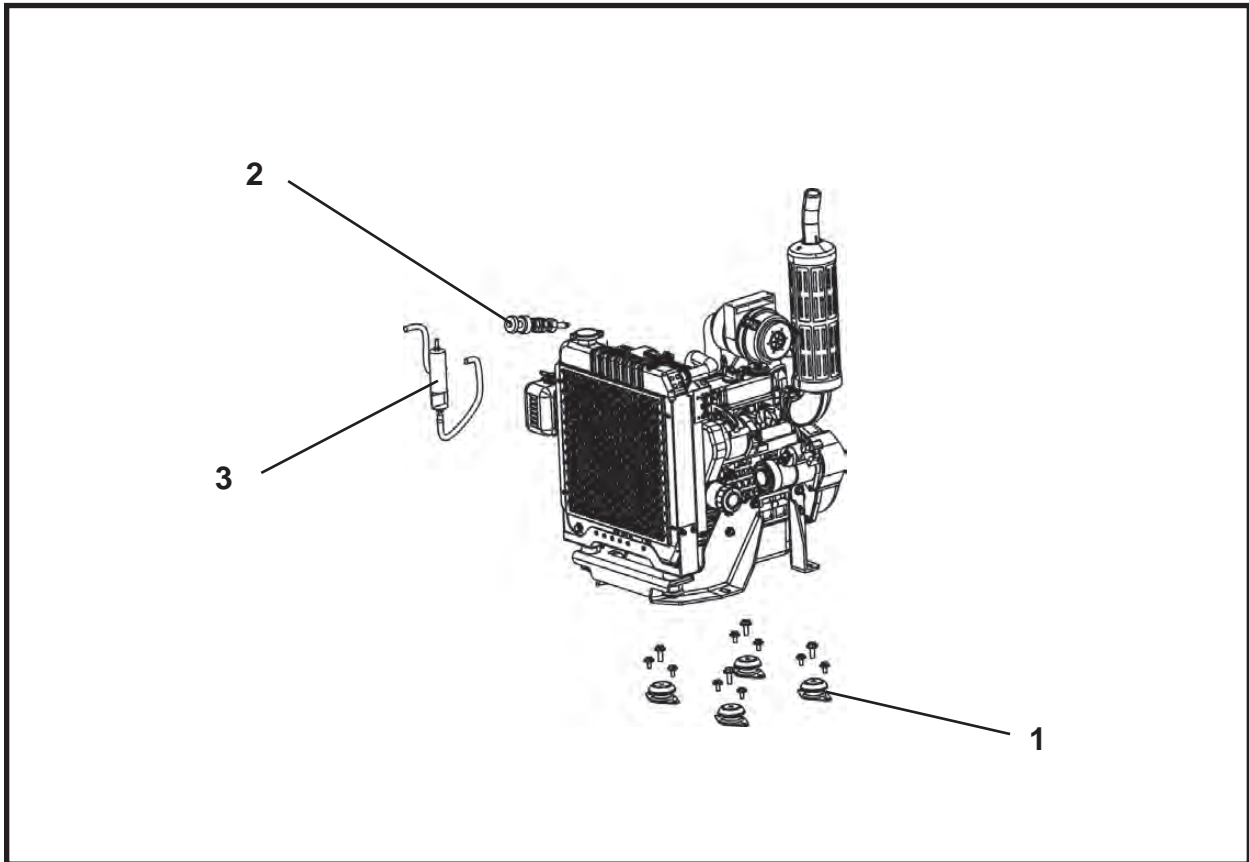

ITEM	QTY	PART NO.	DESCRIPTION
0	1	P0125-163	ENGINE, Diesel 20.7 HP
1	1	P0125-163A	ISOLATOR, Vibration Control
2	1	P0125-163B	CONTROL, Throttle
3	1	P0125-163C	PUMP, Electric Fuel

For engine parts, contact your local Kubota engine distributor.

Alphabetical Index

A

Accidental fluid injection 1-2
After each drive, maintenance chart - 9-10
After each drive, maintenance instructions - ... 9-36
Agitator, in-tank 4-1
Air cleaner 9-2
Air cleaner components 6-12
Air cleaner filter element 9-30
Air intake 9-26
Alphabetical index 17-1
Ambient temp 8-2

B

Battery 9-4
Battery acid 1-3
Battery cables 9-20
Battery, check 9-20
Battery mount 9-20
Battery safety 1-3
Bentonite 6-4, 6-17
Bentonite & lubrication pump specifications .. 12-1
Break-in, engine 6-8

C

Cam lock hose assembly 6-22, 6-23
Capacity, fuel tank 8-1, 12-1
Capacity, hydraulic oil tank 8-2, 9-15, 12-1
Chart, torque 12-2
Charts, maintenance 9-2
Checklist 5-1
Chemical, dangerous 1-4
Chemical exposure 6-17
Chemicals 6-18
Circuit ball valves 4-5
Clean and inspect equipment 1-6
Cleaning tank 6-18
Clothing, protective 1-1
Cold weather operation 6-21
Cold weather protection 9-17
Cold weather protection - draining system 6-22
Cold weather protection - using rv anti-freeze
solution 6-24
Compressed air 6-21
Contents iii
Control, fluid volume 4-2
Control, pump/mixer 4-1
Control, pump/mixer 6-8, 6-10, 6-13
..... 6-15, 6-17, 6-24
Control, pump shaft 4-5
Control, shaft 6-24
Controls & instruments 4-1
Coolant, engine 8-3
Cooling 9-13
Covers, inspect 9-16
Cutter head 6-4, 6-7
Cutter head lubrication 4-5
Cuttings, flush 6-2

D

Daily or every 10 hours of operation,
maintenance chart - 9-2
Daily or every 10 hours of operation,
maintenance instructions - 9-11
Daily pre-start inspection 5-1
Daily shutdown 6-15
Dangerous chemicals 1-4
Decals 2-1, 9-17
Decals, inspect 9-17
Decals, jetting & lubrication pump
shaft control 16-8
Decals - lubrication & bentonite pump
..... 16-4, 16-5, 16-6, 16-7
Dipstick 8-2, 9-11, 9-19, 9-22
Displaceable ground 6-2, 6-4
Draining system, cold weather protection 6-22
Drain plug, oil 9-18, 9-21
Drain tank 6-22, 6-24
Dual walled pilot tubes 6-5

E

Element, air cleaner filter 9-30
Engine 3-2, 8-2, 9-2, 9-3, 9-5, 9-6, 9-27
Engine, 20.7 hp parts 16-18
Engine break-in 6-8
Engine coolant 8-3
Engine crankcase 9-2, 9-3, 9-5
Engine crankcase oil level 9-11
Engine does not start 11-1
Engine exhaust 1-4
Engine exhaust warning back inside cover
Engine fuel shutoff 4-3
Engine, inspect 9-11
Engine key switch 4-3, 4-4
Engine mounts 9-26
Engine oil 6-11, 8-2
Engine oil, change 9-18, 9-21
Engine oil level 9-19, 9-22
Engine oil, sae 15w40 8-2, 9-19, 9-22
Engine, shutdown 6-15
Engine, shutting down the 6-10
Engine speed 4-4, 6-15
Engine, starting the 6-8
Engine system monitor 4-4
Engine throttle 4-4
Escaping fluids 1-2
Every 100 hours of operation,
maintenance chart - 9-5
Every 100 hours of operation,
maintenance instructions - 9-21
Exhaust fumes 1-4
Eye protection 1-1, 9-20

F

Fill cap 9-19, 9-22
 Filter element, air cleaner 9-30
 Filter gasket 9-15
 Filter indicator, hydraulic return 9-15
 Fire extinguisher 1-5, 9-14
 Fire prevention 1-5
 First 50 hours of operation & every 100 hours
 thereafter, maintenance chart - 9-3
 First 50 hours of operation & every 100 hours
 thereafter, maintenance instructions - ... 9-18
 Fitting kit, hydraulic & water 16-14
 Fluid connector 6-5
 Fluid injection, accidental 1-2
 Fluid lines, pressurized 9-1
 Fluids under pressure 1-2, 9-1
 Fluid volume control 4-2
 Flush cuttings 6-2
 Flush water/solution tank 9-17
 Frame weight 7-1, 12-1
 Freezing weather 6-19, 9-17
 Fuel, inferior 8-1
 Fuel leaks 9-11
 Fuel shutoff, engine 4-3
 Fuel shutoff valve 4-3, 6-10, 6-16
 Fuels & lubricants 8-1
 Fuel specifications 8-1
 Fuel tank cap 9-6
 Fuel tank cap 9-27
 Fuel tank capacity 8-1, 12-1
 Fuel tank level 9-14
 Fumes, exhaust 1-4

G

Gauge, hydraulic tank oil level 9-15
 Gauges, pressure 4-3
 Gbm jetting application i
 Gbm lubrication application i
 Geotech report 6-2
 Green ok zone 9-15
 Guards, inspect 9-16
 Guidelines, lubrication 6-2
 Guidelines, operating 6-1
 Guidelines, transporting 7-1

H

Hardware specification 16-2
 Hookup, lubrication circuit 6-4
 Hopper 6-17, 6-19
 Hose kit, hydraulic & water 16-15
 Hydraulic oil 8-2
 Hydraulic oil pressure 4-3
 Hydraulic oil tank capacity 8-2, 9-15, 12-1
 Hydraulic return filter indicator 9-15
 Hydraulic tank 9-2
 Hydraulic tank oil 8-2
 Hydraulic tank oil level 6-12
 Hydraulic tank oil level gauge 9-15

H (continued)

Hydraulic & water assembly parts
 16-12, 16-13
 Hydraulic & water fitting kit 16-14
 Hydraulic & water hose kit 16-15

I

Identification numbers 13-1
 Ignition key, engine 4-3, 4-4
 Index, alphabetical 17-1
 Index, numerical 18-1
 Indicator, hydraulic return filter 9-15
 Inferior fuel 8-1
 Inspect and clean equipment 1-6
 Inspection, daily pre-start 5-1
 Inspection, pre-start 5-1
 Instructions, maintenance 9-2, 9-3
 Instruments & controls 4-1
 In-tank agitator 4-1
 Introduction i
 Introduction, parts 16-2
 ISO-VG-46 8-2
 ISO-VG-68 8-2

J

Jetting application i
 Jetting & lubrication pump shaft
 control decals 16-8
 Jetting & lubrication shaft control parts 16-16
 Jetting, powered reaming head 4-5, 6-4
 Jetting, powered reaming head 6-6
 Job site clean and organized 1-6

L

Leakproof containers 1-7
 Levers, inspect 9-16
 Lifting instructions 7-1
 Loads, suspended 1-2
 Locating parts 16-2
 Lubricant per 300 ft drive 6-2
 Lubricant per ft 6-2
 Lubricants & fuels 8-1
 Lubricants, storing 8-3
 Lubricant, usage of 6-2
 Lubricating outside of casing with
 reaming head 6-5
 Lubricating outside of pilot tubes 6-4
 Lubricating spoils for open cutter head 6-5
 Lubricating spoils for reaming head 6-5
 Lubrication application i
 Lubrication & bentonite pump assembly parts
 16-10, 16-11
 Lubrication & bentonite pump decals -
 16-4, 16-5, 16-6, 16-7
 Lubrication & bentonite pump specifications 12-1
 Lubrication & bentonite pump terminology 3-1
 Lubrication circuit hookup 6-4

L (continued)

Lubrication, cutter head 4-5
 Lubrication guidelines 6-2
 Lubrication, pilot tube 4-5
 Lubrication, pilot tube adapter 4-5
 Lubrication ports 6-5
 Lubrication pump is pulsating 11-1
 Lubrication pump, setting up 6-3
 Lubrication, reaming head 4-5
 Lubrication, shaft control for 6-7
 Lubrication, steering head 4-5

M

Maintenance chart - after each drive 9-10
 Maintenance chart - daily or every 10 hours of operation 9-2
 Maintenance chart - every 100 hours of operation 9-5
 Maintenance chart - every 400 hours of operation 9-7
 Maintenance chart - every 500 hours of operation 9-8
 Maintenance chart - every 1000 hours of operation 9-9
 Maintenance chart - every 2000 hours of operation 9-9
 Maintenance chart - first 50 hours of operation & every 100 hours thereafter 9-3
 Maintenance chart - monthly or every 200 hours of operation 9-6
 Maintenance charts 9-2
 Maintenance chart - weekly or every 50 hours of operation 9-4
 Maintenance detail, every 2000 hours or every 2 years of operation 9-35
 Maintenance instructions 9-2, 9-3, 9-4
 Maintenance instructions - after each drive 9-36
 Maintenance instructions - daily or every 10 hours of operation 9-11
 Maintenance instructions - every 100 hours of operation 9-21
 Maintenance instructions - every 400 hours of operation 9-28
 Maintenance instructions - every 500 hours of operation 9-29
 Maintenance instructions - every 1000 hours of operation 9-33
 Maintenance instructions - every 2000 hours of operation 9-35
 Maintenance instructions - first 50 hours of operation & every 100 hours thereafter 9-18
 Maintenance instructions - monthly or every 200 hours of operation 9-26
 Maintenance instructions - weekly or every 50 hours of operation 9-20
 Maintenance, periodic 9-1
 Maintenance, requirements 9-1
 Maintenance, safe 1-5
 Measurements 16-2

M (continued)

Medical help 9-1
 Mixer control 4-1
 Mixer not functioning 11-1
 Mixing tank 6-17
 Monitor, Engine System 4-4
 Monthly or every 200 hours of operation, maintenance chart - 9-6
 Monthly or every 200 hours of operation, maintenance instructions - 9-26
 Msha 5-1

N

No water discharge out of pump 11-1
 Numbers, identification 13-1

N (continued)

Numbers, serial 13-1
 Numerical index 18-1

O

Oil capacity 9-19, 9-22, 12-1
 Oil capacity, engine 9-19, 9-22
 Oil dipstick 8-2
 Oil drain plug 9-18, 9-21
 Oil, engine 6-11
 Oil, engine 8-2
 Oil, hydraulic 8-2
 Oil, hydraulic tank 8-2
 Oil level, engine crankcase 9-11
 Oil, sae 15w40 8-2
 Oil, sae 15w40, engine 9-19, 9-22
 Oil tank capacity, hydraulic 8-2, 12-1
 Open cutter head, lubricating spoils for 6-5
 Operating guidelines 6-1
 Operation 6-1
 Operation, cold weather 6-21
 Operator controls parts 16-17
 Operator's manual, read 1-1
 Ordering, parts 16-2
 Osha 5-1
 Outlet tube 9-17
 Outlet tube, inspect 9-17

P

Parts 16-1
 Parts introduction 16-2
 Parts, locating 16-2
 Parts ordering 16-2
 Periodic maintenance 9-1
 Permits 7-1
 PH 6-17
 Pilot tube adapter 4-5, 6-4
 Pilot tube adapter for lubrication 6-4, 6-7
 Pilot tube lubrication 4-5
 Pilot tubes, dual walled 6-5
 Pilot tube to trihawk adapter with tri-hawk drill bit fluid path 6-4

P (continued)

Pinch points 1-3, 9-1
 Plug, oil drain 9-18, 9-21
 Polymer 9-17
 Polymers 6-4, 6-17
 Port, pressure 4-5
 Port, return 4-5
 Powered reaming head jetting 4-5, 6-4
 Powered reaming head jetting 6-6
 PPE 1-1, 1-4, 5-1, 6-17, 6-18
 Precleaner 9-2
 Preparing for storage 10-1
 Pressure, fluids under 1-2, 9-1
 Pressure gauge 4-3
 Pressure hose, inspect 9-17
 Pressure port 4-5, 6-22
 Pressure shutoff valve 4-2
 Pressure washer wand 1-2, 9-1
 Pressure washer wand or auxiliary 6-6
 Pressurized fluid lines 1-2, 9-1
 Pre-start inspection 5-1
 Pre-start inspection, daily 5-1
 PRH 6-7
 Procedure, start up 6-11
 Protection, cold weather - draining system 6-22
 Protection, cold weather - using rv anti-freeze
 solution 6-24
 Protective clothing 1-1, 9-20
 Pump cannot reach maximum pressure 11-1
 Pump/mixer control 4-1
 Pump/mixer control 6-8, 6-10, 6-13, 6-15,
 6-17, 6-24
 Pump mounting bolts 9-26
 Pump, setting up lubrication 6-3
 Pump shaft control 4-5
 Pump shaft control terminology 3-3
 Pure water 6-17

Q

Quadcon container 6-21

R

Reaming head 6-4, 6-7
 Reaming head, lubricating outside of
 casing with 6-5
 Reaming head, lubricating spoils for 6-5
 Reaming head lubrication 4-5
 Recycle waste 1-7
 Refueling 1-3
 Removing from storage 10-2
 Requirements, maintenance 9-1
 Return port 4-5, 6-22
 Return shutoff valve 4-2
 Rv anti-freeze 9-36
 Rv anti-freeze solution 6-21, 9-17
 Rv anti-freeze solution, cold weather protection,
 using 6-24

S

Sae 15w40 engine oil 9-19, 9-22
 Sae 15w40 oil 8-2
 Safe maintenance 1-5
 Safety 1-1
 Safety, battery 1-3
 Safety data sheets 14-1
 Safety decals 2-1
 Safety information 1-1
 Serial numbers 13-1
 Setting up lubrication pump 6-3
 Shaft control 6-13, 6-24
 Shaft control for lubrication 6-7
 Shaft control, pump 4-5
 Shaft control terminology pump 3-3
 Shutdown, daily 6-15
 Shutdown engine 6-15
 Shutoff, engine fuel 4-3
 Shutting down the engine 6-10
 Sight gauge 6-12
 Slippery when wet 1-5
 Soda ash 6-17
 Soft rock 6-2, 6-4
 Solution mixing 4-1
 Specification, hardware 16-2
 Specifications 12-1
 Specifications, 1325b lubrication &
 bentonite pump 12-1
 Specifications, fuel 8-1
 Speed, engine 4-4, 6-15
 Starting the engine 6-8
 Start up procedure 6-11
 Steering head adapter with steering head bit
 fluid path 6-4
 Steering head for lubrication 6-4, 6-7
 Steering head lubrication 4-5
 Storage 10-1
 Storage, preparing for 10-1
 Storage, removing from 10-2
 Storing lubricants 8-3
 Strainer 6-12, 6-18, 6-22, 6-23
 Strainer, tank 9-11
 Suspended loads 1-2
 System, Engine Monitor 4-4
 Switch, engine key 4-3, 4-4

T

Tank capacity, fuel 8-1, 12-1
 Tank capacity, hydraulic oil 8-2
 Tank, cleaning 6-18
 Tank, mixing 6-17
 Tank recirculation 4-1
 Tank return hose 6-23
 Tank shut off valve 4-2
 Tank strainer 9-11
 Tank, water/solution 9-36
 Temp, ambient 8-2

Alphabetical Index

T (continued)

Terminology 3-1
 Terminology, lubrication & bentonite pump 3-1
 Terminology, pump shaft control 3-3
 Throttle, engine 4-4
 Torque chart 12-2
 Transportation regulations 7-1
 Transporting 7-1
 Transporting guidelines 7-1
 Tri-hawk® drill bit 6-4
 Tri-hawk® drill bit 6-2
 Troubleshooting 11-1

U

Unauthorized welding 1-6
 Usage of lubricant 6-2

V

Valves, circuit ball 4-5
 Valves, inspect 9-16
 Valve, tank shut off 4-2
 Volume control, fluid 4-2

W

Warning, engine exhaust inside back cover
 Warranty 15-1
 Washer wand 4-5, 6-4, 6-7
 Washer wand, 1-2
 Washer wand, pressure 1-2, 9-1
 Waste, recycle 1-7
 Water hardness 6-17
 Water, pure 6-17
 Water/solution tank 9-10
 Water/solution tank 9-36
 Water/solution tank, flush 9-17
 Water tank, inspect 9-16
 Weather, freezing 9-17
 Weekly or every 50 hours of operation,
 maintenance chart - 9-4
 Weekly or every 50 hours of operation,
 maintenance instructions - 9-20
 Weight, frame 7-1, 12-1
 Welding, unauthorized 1-6
 Wiring, inspect 9-16

Y

Yellow zone 9-15

NOTES

Numerical Index

PART NO.	PAGE NO.	PART NO.	PAGE NO.	PART NO.	PAGE NO.
012945P00	16-11	1251-762L	16-6	A49060A	16-13
1250-098	16-7	1251-762R	16-4	A49060A	16-15
1250-311	16-5	1251-762R	16-6	A49061A	16-13
1250-311	16-6	1251-763	16-6	A49061A	16-14
1250-483	16-7	A08270A	16-11	FA48850F	16-11
1250-498c	16-7	A08283A	16-11	P0001-04-003	16-11
1250-544	16-7	A09876A-033	16-15	P0001-04-004	16-11
1250-558	16-4	A09876A-041	16-15	P0001-04-005	16-11
1250-558	16-6	A09876A-044	16-15	P0001-04-010	16-12
1250-638	16-5	A09877A-032	16-15	P0001-05-004	16-11
1250-638	16-6	A09877A-043	16-15	P0001-06-004	16-16
1250-649	16-6	A09882A-043	16-15	P0001-06-005	16-11
1250-697	16-7	A10068A-028	16-15	P0001-08-004	16-11
1250-917	16-16	A10311A-018	16-15	P0001-08-004	16-13
1250-917a	16-8	A10324A-014	16-15	P0001-08-005	16-11
1250-917b	16-8	A10324A-025	16-15	P0001-08-005	16-11
1250-917c	16-8	A10324A-026	16-15	P0001-08-008	16-11
1251-016	16-7	A10342A-023	16-15	P0001-08-012	16-11
1251-021	16-7	A10361A-045	16-15	P0003-04-000	16-12
1251-023	16-5	A10368A-028	16-15	P0003-06-000	16-16
1251-221	16-4	A3000-1	16-5	P0013-03.5A-000	16-11
1251-221	16-6	A40128A	16-11	P0013-04-000	16-11
1251-228	16-5	A43749A	16-11	P0013-04-000	16-11
1251-228	16-7	A43749A	16-16	P0013-06A-000	16-11
1251-246	16-5	A43754P	16-16	P0013-08A-000	16-11
1251-246	16-6	A43757A	16-16	P0020-14-205	16-11
1251-247	16-7	A44455P	16-11	P0031-06-004	16-13
1251-527	16-7	A47891A	16-11	P0032-002	16-11
1251-677	16-4	A48356P	16-11	P0040-004	16-11
1251-677	16-6	A48401P	16-11	P0040-004	16-13
1251-678	16-5	A48411P	16-11	P0040-005	16-11
1251-678	16-6	A48479P	16-11	P0040-005	16-12
1251-679	16-5	A48598A	16-11	P0040-006	16-11
1251-680b	16-5	A48826A	16-11	P0040-006	16-16
1251-681	16-7	A48851P	16-11	P0040-008	16-11
1251-685	16-5	A48854A	16-11	P0040-008	16-11
1251-686a	16-5	A48856P	16-11	P0040-008	16-13
1251-710	16-5	A48857A	16-11	P0040-012	16-13
1251-753	16-5	A48858A	16-11	P0040-016	16-13
1251-757	16-5	A48862P	16-11	P0042-013	16-11
1251-757	16-7	A48863P	16-11	P0047-003	16-11
1251-758	16-7	A48865A	16-11	P0064-019	16-11
1251-759	16-7	A48865A	16-12	P0093-036A	16-13
1251-760	16-7	A48899P	16-13	P0095-128	16-11
1251-761	16-6	A49057P	16-11	P0100-121	16-13
1251-762L	16-5	A49059A	16-11	P0100-122	16-13

Numerical Index

PART NO.	PAGE NO.	PART NO.	PAGE NO.
P0102-113	16-11	P0300-399	16-16
P0102-115	16-11	P0300-479	16-14
P0125-161	16-11	P0300-567	16-14
P0125-161A	16-11	P0300-567	16-16
P0125-162	16-13	P0300-568	16-16
P0125-163	16-11	P0300-569	16-16
P0125-163	16-18	P0300-570	16-16
P0125-163A	16-11	P0300-571	16-16
P0125-163A	16-18	P0300-588	16-14
P0125-163B	16-17	P0300-688	16-14
P0125-163B	16-18	P0300-868	16-14
P0125-163C	16-11	P0300-873	16-14
P0125-163C	16-18	P0300-874	16-14
P0126-038	16-13	P0300-879	16-14
P0201-238-024	16-13	P0300-880	16-14
P0201-240	16-11	P0300-881	16-14
P0201-241	16-11	P0300-884	16-14
P0201-247	16-13	P0300-886	16-14
P0201-299	16-13	P0300-891	16-14
P0220-349	16-11	P0300-892	16-14
P0251-800	16-13	P0301-100	16-16
P0258-004	16-13	P0301-105	16-13
P0258-005	16-13	P0301-141	16-13
P0258-006	16-13	P0302-102	16-13
P0258-006	16-17	P0302-507	16-16
P0258-012	16-13	P0302-696	16-12
P0258-013	16-13	P0302-696	16-17
P0258-015	16-13	P0302-696A	16-12
P0258-018	16-13	P0302-696A	16-17
P0258-066	16-11	P0302-701	16-13
P0258-069	16-13	P0302-801	16-13
P0258-070	16-13	P0302-801	16-17
P0300-053	16-14	P0302-802	16-16
P0300-057	16-14	P0303-396	16-12
P0300-060	16-14	P0303-396A	16-12
P0300-093	16-16	P0303-396B	16-12
P0300-126	16-14	P0303-408	16-13
P0300-126	16-16	P0304-347	16-13
P0300-130	16-16	P0308-110	16-13
P0300-142	16-16	P0309-217	16-13
P0300-147	16-14	P0309-217A	16-13
P0300-305	16-14	PM08A-1.25-016	16-12
P0300-316	16-14	PM10A-1.50-030	16-11
P0300-317	16-14		
P0300-318	16-14		
P0300-319	16-14		
P0300-325	16-14		
P0300-332	16-14		
P0300-372	16-14		
P0300-385	16-14		

WARNING

The engine exhaust from this product contains chemicals known to the State of California to cause cancer, birth defects or other reproductive harm.