



# **OPERATOR'S MANUAL**

## **P100E Power Pack Supplement for the 240A, 308A & 339A Operator's Manual**

**Publication No. 050100A**

Rev. No. 150807 R190710

© Akkerman Inc. 2015  
All Rights Reserved

Akkerman Inc. 58256 266th Street Brownsdale, MN 55918  
Phone: 507-567-2261 Fax: 507-567-2605 email: [akk@akkerman.com](mailto:akk@akkerman.com)

**SERVICE • RELIABILITY • INNOVATION**



# Introduction

This supplement to your 240A, 308A and 339A Operator's Manual contains important safety, operation, and maintenance information for your Akkerman P100E Power Pack. You must read and understand this manual, the 240A, 308A and 339A Operator's Manual, and your electric motor Installation, Operation and Maintenance Instructions (refer to page 67) booklet before you operate and maintain this equipment. Keep this manual with your Power Pack at all times. Additional copies of this supplement is available from the Akkerman Aftermarket Support Department.

The contractor is responsible for the overall safety program on the job site. Use this manual as a part of the safety program.

The use of second rate parts could affect the efficient performance of the Power Pack. ALWAYS use genuine Akkerman parts.

Understand safety signal words, DANGER, WARNING, CAUTION, SAFETY INSTRUCTIONS, and NOTICE. When you see these words in this manual or on safety decals mounted on your equipment, follow the safety message to avoid personal injury and/or property damage.

**⚠ DANGER** Indicates an extremely hazardous situation which, if not avoided, WILL result in death or serious injury.

**⚠ WARNING** Indicates a potentially hazardous situation which, if not avoided, COULD result in death or serious injury.

**⚠ CAUTION** Indicates a potentially hazardous situation, which, if not avoided, MAY result in minor or moderate injury. It may also be used to alert against unsafe practices.

**SAFETY INSTRUCTIONS** Usually consists of individual messages stating procedures or actions that must be followed for the safe operation of a product.

**NOTICE** Identifies potential property damage and important installation, operator, or maintenance information.



**P100E Power Pack**

If you find any errors with this supplement or know of ways to improve procedures, please let us know. Mail your suggestions to: Akkerman Inc, ATTN: Technical Publications, 58256 266th Street, Brownsdale, MN 55918.

Akkerman Inc. reserves the right to improve its product without notice or obligation.

## **NOTES**

# Contents

<b>Safety</b> .....	<b>7</b>	<b>Periodic Maintenance</b> .....	<b>39</b>
<b>Safety Decals</b> .....	<b>15</b>	Lubrication & Maintenance Intervals .....	39
<b>Terminology</b> .....	<b>17</b>	Lockout Power Before Servicing .....	39
Power Pack P100E .....	17	Avoid Pinch Points .....	39
Control Panel .....	18	Using Emergency Stop .....	40
Control Panel (Interior) .....	19	Hydraulic Oil/Fluids Under Pressure .....	40
<b>Controls &amp; Instruments</b> .....	<b>21</b>	Maintenance Chart .....	41-42
Power Pack P100E Controls .....	21	Maintenance Detailed Procedures .....	43
Control Pendant .....	22	Electric Motor Maintenance .....	43
Phase Indicators .....	23	Prior To Each Job Launch .....	43
Lights .....	24	Daily Or Every 10 Hours .....	44
Motor Load % .....	24	Weekly Or Every 50 Hours .....	51
Oil Cooler Fan .....	25	Completion of Each Drive .....	42
Motor Hourmeter .....	25	Every 500 Hours .....	53
<b>Operation</b> .....	<b>27</b>	Every 1000 Hours .....	54
Using Emergency Stop .....	27	Annually .....	57
Connecting Power Leads .....	28	<b>Troubleshooting</b> .....	<b>59</b>
Starting The Motor .....	29	Control Pendant .....	59
Stopping The Motor .....	30	P100E Electrical Schematic .....	60
Check Hydraulics After Motor Start-Up .....	30	480V .....	60
Adjusting Thrust Pressure .....	31	400V .....	61
Filling The Hydraulic Oil Reservoir .....	32	Electrical Motors .....	62
Daily Shutdown .....	35	P100E Hydraulic Schematic .....	63
<b>Lubricants</b> .....	<b>37</b>	<b>Specifications</b> .....	<b>63</b>
Power Pack Hydraulic Oil Reservoir .....	37	P100E Features & Specifications .....	63
Grease .....	37	Relay Settings .....	64
Storing Lubricants .....	37	<b>Motor Installation, Operation and Maintenance Instructions</b> .....	<b>65</b>

**NOTES**

# Safety

---

## BE ALERT FOR SAFETY INFORMATION

When you see this safety alert symbol on your equipment or in this manual, be alert to the possibility of personal injury or property damage.

Read all safety information.

Keep safety decals clean and in good condition.  
Replace missing or damaged safety decals.



**ATTENTION!  
BECOME ALERT!  
YOUR SAFETY IS INVOLVED!**

---

## READ OPERATOR'S MANUAL

**⚠ WARNING** Unsafe operation or maintenance can cause severe injury or death.

Read and understand the Operator's Manual before operating or servicing this equipment.

Any unauthorized modifications will void the warranty.

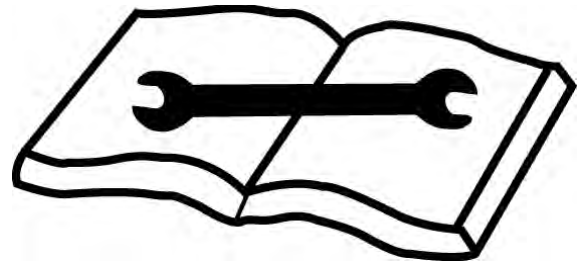

---

## WEAR PROTECTIVE CLOTHING

Wear OSHA approved protective clothing, such as hard hat, gloves, safety goggles, earmuffs or ear plugs, face shield, and steel-toed boots, when operating and servicing this equipment.

Wear reasonably close fitting clothing and remove jewelry before working on or near this equipment. This will help prevent the danger of catching them in moving parts or controls.



---

## LOCKOUT TAGOUT POWER BEFORE SERVICING

**⚠ DANGER** Failure to lockout tagout power before servicing will cause severe personal injury or death.

LOCKOUT TAGOUT main power supply before servicing. Electrical repairs must be performed only by a certified electrician.



---

## HYDRAULIC OIL/FLUIDS UNDER PRESSURE

**⚠ WARNING** Escaping oil or other fluids under pressure can penetrate your skin causing serious injury.

Release all pressure before performing maintenance or repairs. Never weld near pressurized fluid lines.

DO NOT use your hands to check for leaks. When searching for leaks, use a piece of wood or cardboard.

Contact medical help immediately if any oil or fluid is injected into your skin. A serious infection or reaction can emerge without proper medical treatment.



---

## UNAUTHORIZED WELDING

**⚠ WARNING** Unauthorized welding can cause structural failure resulting in possible injury or death.

Do not weld on any structural member.  
Unauthorized welding or repair will void the warranty.

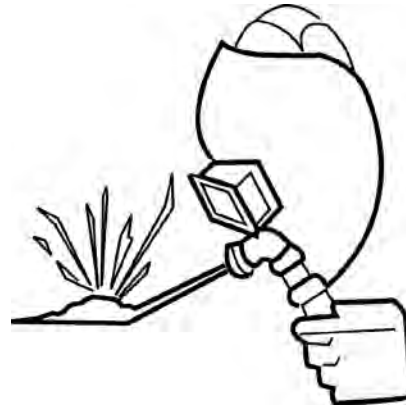

---

## BEWARE OF SUSPENDED LOADS

**⚠ WARNING** Suspended loads may fall and cause severe personal injury or death.

If a hydraulic hose breaks from the boom of a crane/excavator, or the lifting support fails, the boom and/or load can fall instantly.

Do not enter area under or around a suspended load.



---

## KEEP PERSONNEL AWAY FROM MOVING PARTS

**⚠ WARNING** Crushing hazard.  
Keep personnel away from inside of GBM when jacking or moving GBM. Failure to do so could result in serious personal injury or death.



---

## USING PLUMB BOB

**⚠ WARNING** Falling plumb bob can cause serious personal injury or death, and/or equipment damage.

NEVER hang or secure the plumb bob overhead when not in use.

ALWAYS remove the plumb bob from the string lines and place in storage container after use.



---

## HANDLING AUGER CASINGS

**⚠ WARNING** Auger may fall out of casing and cause severe injury or death if casing tips or hits an obstruction.

Properly install safety chain assembly or casing auger pin to augers and casings before lowering into or lifting out of shaft.

Do not stand or walk under a load.



---

## REGULARLY CLEAN AND INSPECT EQUIPMENT

Remove any grease, oil, or debris buildup to avoid potential injury or equipment damage.

Inspect equipment for damage. If damaged, repair or replace immediately.

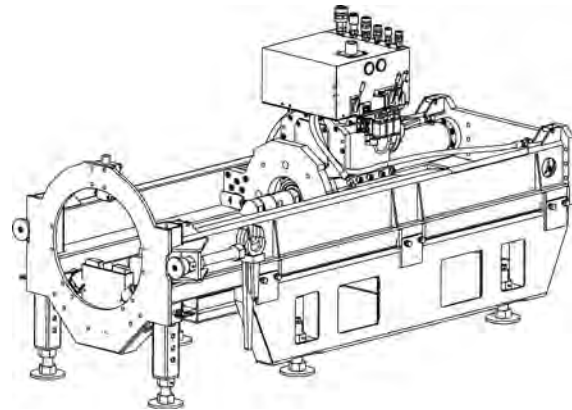

---

## PRACTICE SAFE MAINTENANCE

**⚠ WARNING** Unexpected Jacking System movement may cause serious personal injury.

LOCKOUT power before performing any maintenance.

Shut down GBM before making repairs, adjustments, or removing obstructions.

Only trained and qualified personnel should perform maintenance or repairs.

Keep the area around the equipment clean and dry when performing maintenance.

Do not service the machine while it is in motion.

Replace worn or damaged parts. Remove grease, oil, or debris buildup.



## AVOID PINCH POINTS

**⚠ WARNING** Moving parts or the mishandling of parts can cause severe personal injury.

Keep hands away from moving parts.

Watch your fingers, hands, and legs while equipment is in operation.

Handle parts carefully to avoid crushing and pinch point hazards.



## ROTATING COOLING FAN BLADES

**⚠ WARNING** Serious personal injury could result if contact is made with rotating fan blade. Fan blades can rotate at any time power is connected and the main disconnect is in the ON position.

If the power is connected to the power pack and the main disconnect is in the ON position, the fan can rotate anytime the hydraulic oil is at 120°F (49°C) (factory default setting).

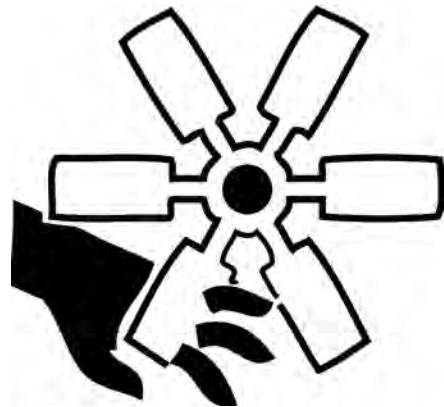

## TEST SHAFT & TUNNEL VENTILATION

**⚠ WARNING** Keep shafts and tunnel well ventilated at all times.

Use an approved air analyzer to detect hazardous gases and oxygen content.

Before and during the shaft operation, test for combustible and toxic gases and oxygen deficiency.

If the levels exceed OSHA prescribed levels, leave tunnel and shaft immediately! Do not activate or deactivate any electrical or hydraulic devices, since any sparks could cause an explosion.

Once ALL personnel are out of tunnel/shaft, cut power from power source.

Gases must be removed before reentering tunnel/shaft.

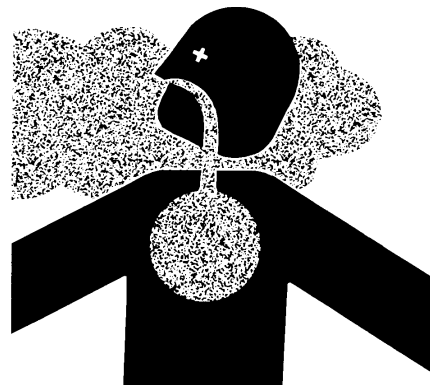

---

## FIRE PREVENTION

**⚠ CAUTION** Fires can cause injury or property damage.

Keep equipment clean. Remove all debris from equipment.

Have a fire extinguisher available at all times. Keep the fire extinguisher fully charged.



---

## HIGH PRESSURE HYDRAULICS

**⚠ WARNING** The GBM contains high pressure hydraulics.

Keep all guards in place.

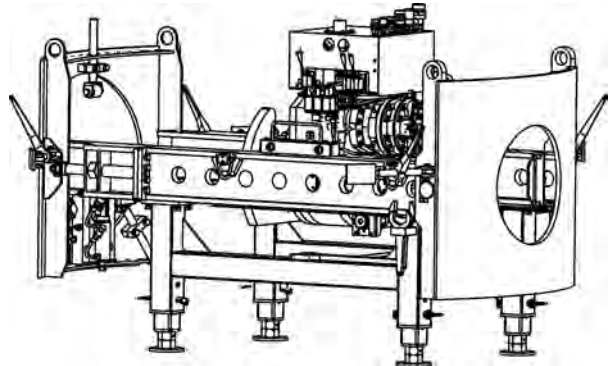

---

## KEEP AWAY FROM AUGER

**⚠ DANGER** Contact with rotating auger will cause severe injury or death.

Keep hands, body, and objects clear of operating auger.

Do not operate without covers and guards in place.

Lockout power before servicing.



---

## SLIPPERY WHEN WET

**⚠ WARNING** Slips and falls can cause serious personal injury.

Ensure firm footing in wet or slippery conditions.

Replace skid-resistant material if it is damaged or missing to prevent slips and falls.

Remove any buildup of grease, oil, or debris.



---

## KEEP JOB SITE CLEAN AND ORGANIZED

**⚠ WARNING** Tripping can cause serious personal injury.

Be sure to keep job site clean and organized.



---

## NO SMOKING IN TUNNEL

**⚠ WARNING** Smoking in tunnel could cause an explosion if combustible gases are present.

Do not smoke in tunnel.



---

## AVOID LASER LIGHT EXPOSURE

**⚠ DANGER** Staring into laser light will cause severe injury.

Do not stare into laser guidance system light beam. Avoid direct eye exposure.

To avoid possible exposure to radiation in excess of acceptable emission limits, all repairs to laser must be performed by the original manufacturer or an authorized service technician.

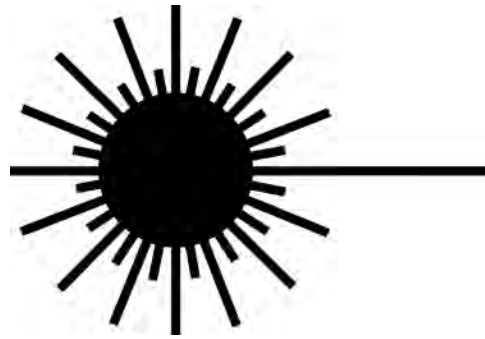

---

## RECYCLE WASTE

Follow local, state, federal, and international regulations when recycling or disposing of waste. Waste includes fluids/oil, filters, coolant, and batteries.

Use leakproof containers when draining fluids/oil. Do not pour waste on the ground, down a drain, or into any water source.

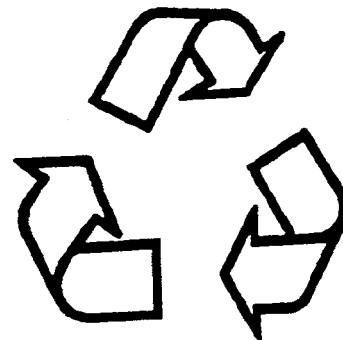

# Safety Decals

## POWER PACK P100E

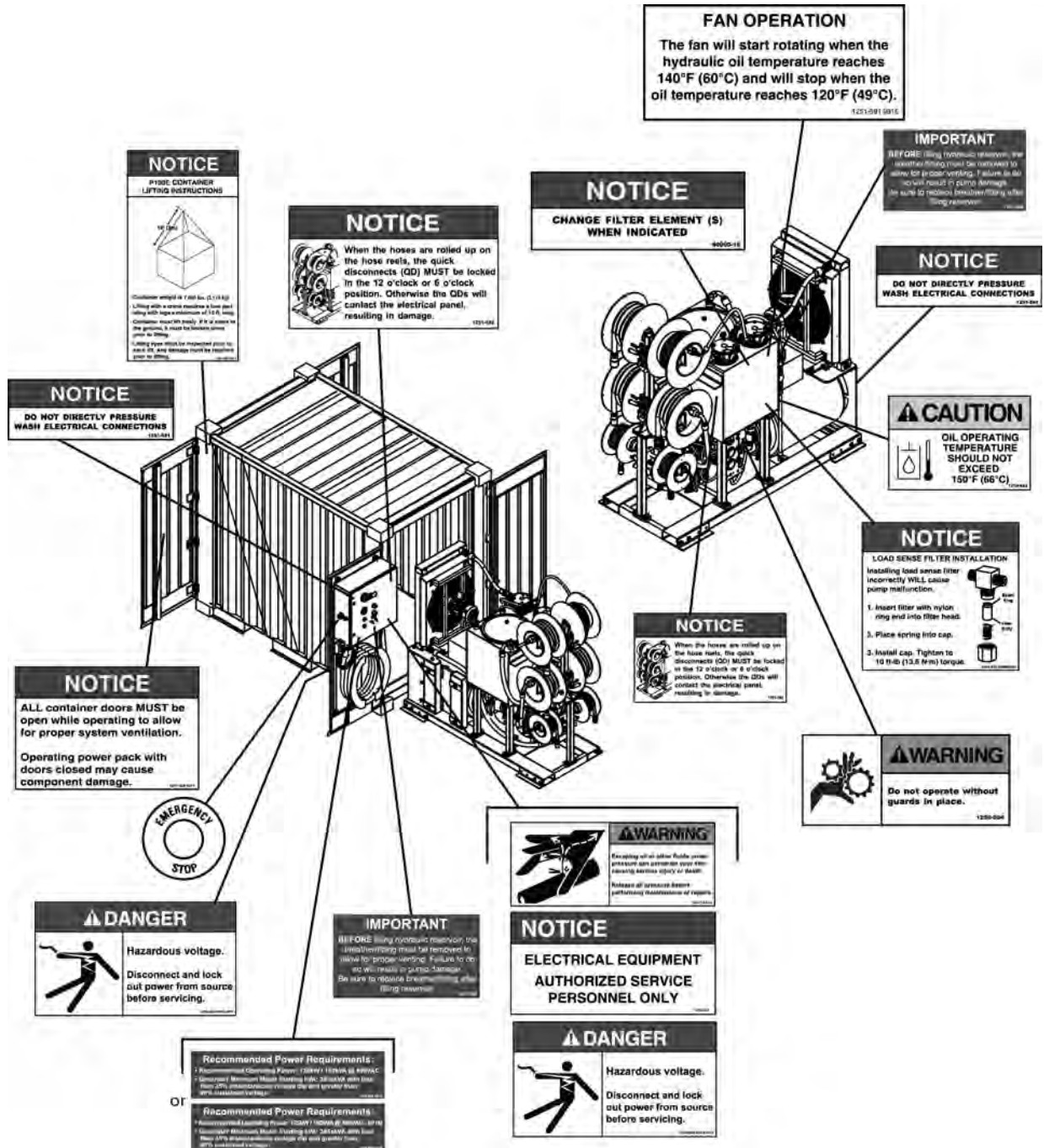

## **NOTES**

# Terminology

## POWER PACK P100E

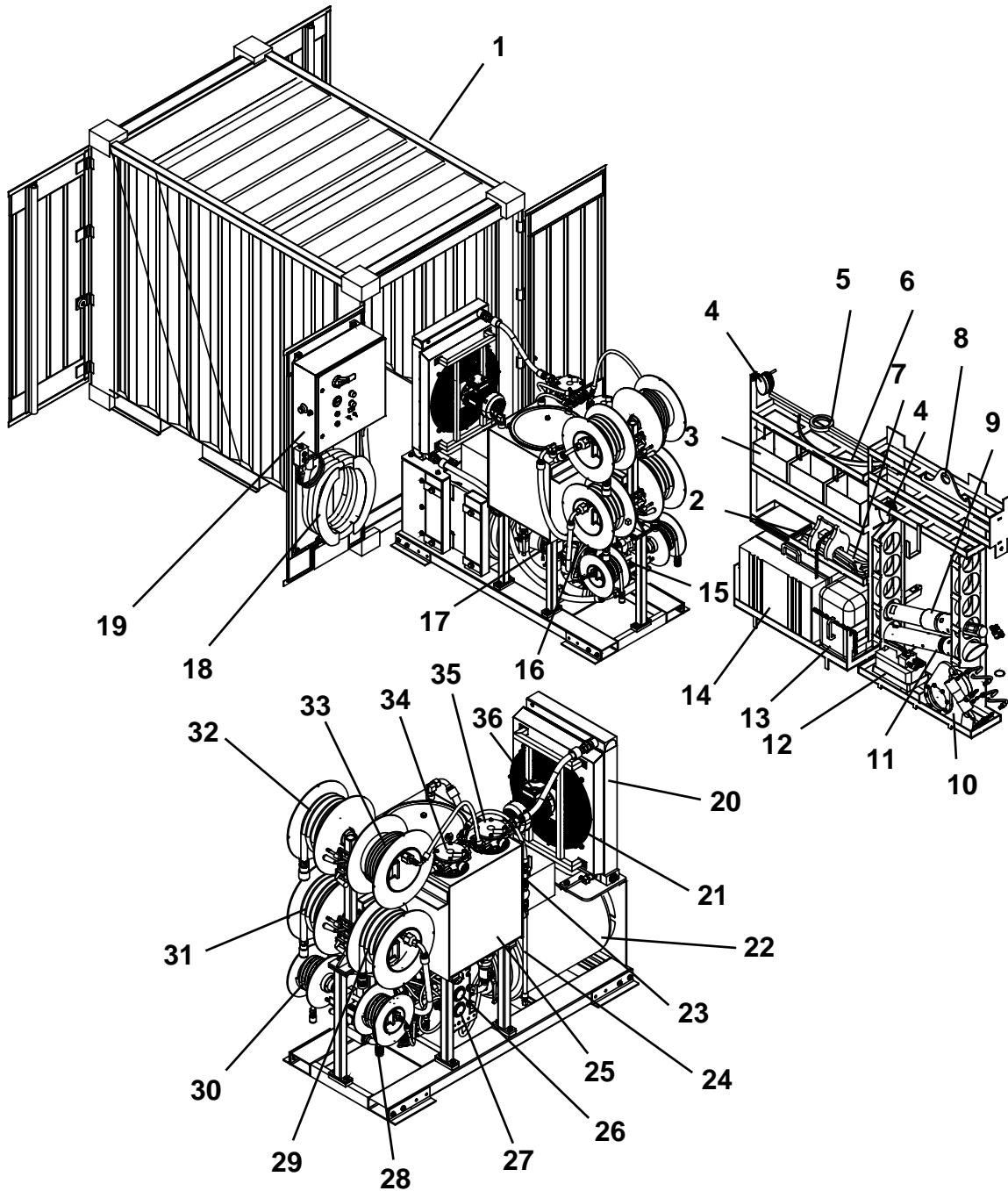

- |                                  |                             |                                     |
|----------------------------------|-----------------------------|-------------------------------------|
| 1. Container                     | 13. Theodolite              | 25. Hydraulic Oil Reservoir 56 Gal. |
| 2. Launch Shaft Breakout Tool    | 14. Guidance System         | 26. Jacking Pressure Gauge          |
| 3. Storage Basket                | 15. Cooling System Pump     | 27. Rotation Pressure Gauge         |
| 4. Light                         | 16. Rotation System Pump    | 28. Rotation Load Sense Hyd. Hose   |
| 5. Pilot Tube Scraper            | 17. Jacking System Pump     | 29. Rotation Pressure Hyd. Hose     |
| 6. Pilot Tube Support Bar        | 18. Power Cord Storage      | 30. Thrust Load Sense Hyd. Hose     |
| 7. Wrench Set                    | 19. Control Panel           | 31. Thrust Pressure Hyd. Hose       |
| 8. Pilot Tube Holder Lifting Bar | 20. Oil Cooler              | 32. Return Hyd. Hose                |
| 9. Pilot Tube Adapter            | 21. Cooling Fan             | 33. Case Drain Hyd. Hose            |
| 10. Dual Tube Breakout Tool      | 22. Electric Motor 100 HP   | 34. Hydraulic Return Filter         |
| 11. Steering Head                | 23. Oil Transfer Pump       | 35. Cooling System Return Filter    |
| 12. Breakout Tool Power Pack     | 24. Hydraulic Oil Fill Hose | 36. Cooling Fan Motor 1.5 HP        |

# CONTROL PANEL

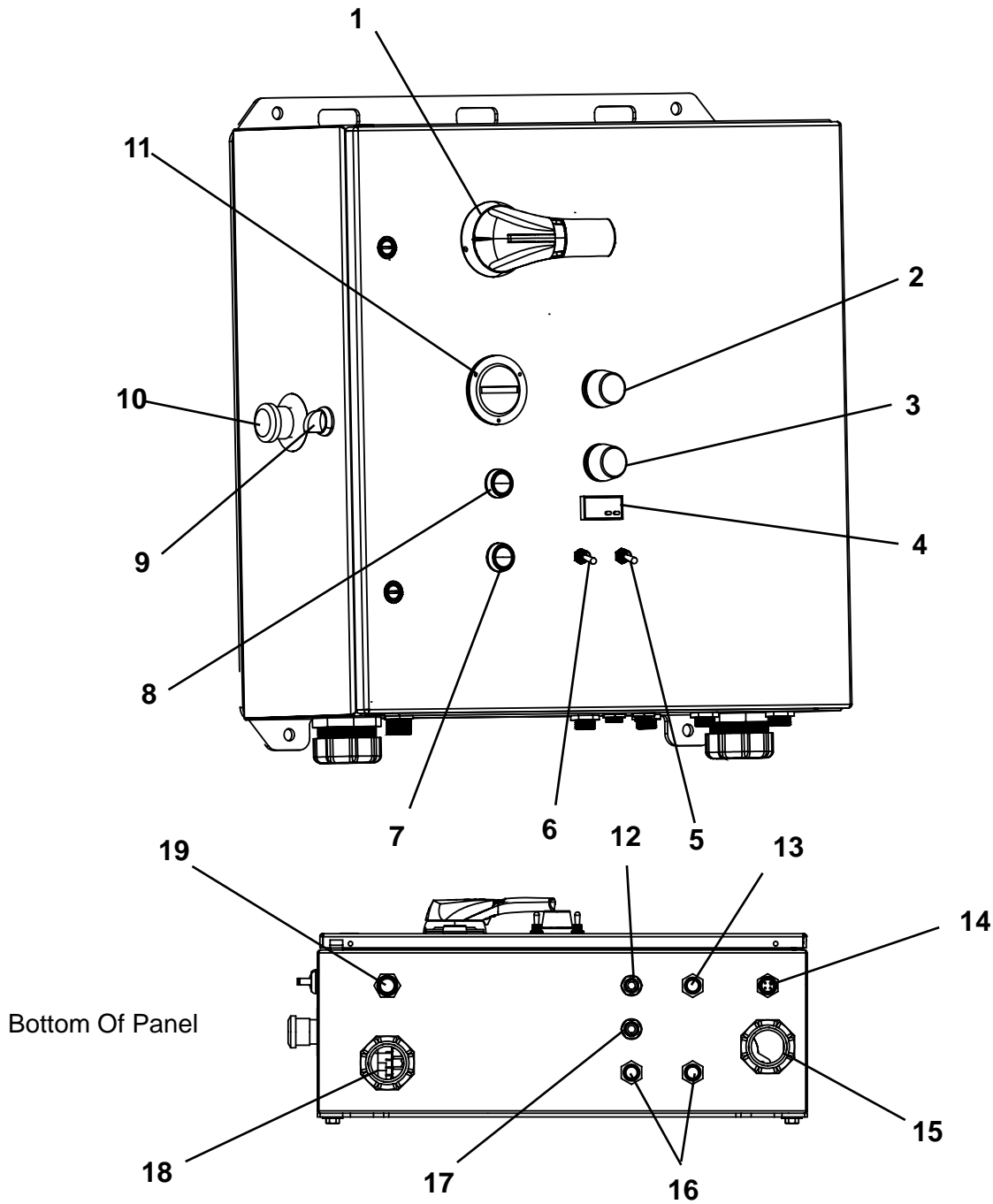

- |  |   |
|--|---|
| 1. Main Power Disconnect               | 10. Emergency Stop                      |
| 2. Phase Indicator - Red Phase Error   | 11. Electric Motor Hourmeter            |
| 3. Phase Indicator - Green Phase OK    | 12. Oil Temperature Switch Connection   |
| 4. Motor Load %                        | 13. Oil Transfer Pump Connection        |
| 5. Light Switch                        | 14. 1.5 HP Cooling Fan Motor Connection |
| 6. Oil Fill Transfer Pump Power Switch | 15. 100 HP Electric Motor Connection    |
| 7. Stop Button                         | 16. Lights Connection                   |
| 8. Start Button                        | 17. Oil Level Switch Connection         |
| 9. Panel/Pendant Control Power Switch  | 18. Generator Power Cable               |
|  | 19. Pendant Power Cable Connection      |

## CONTROL PANEL (INTERIOR)

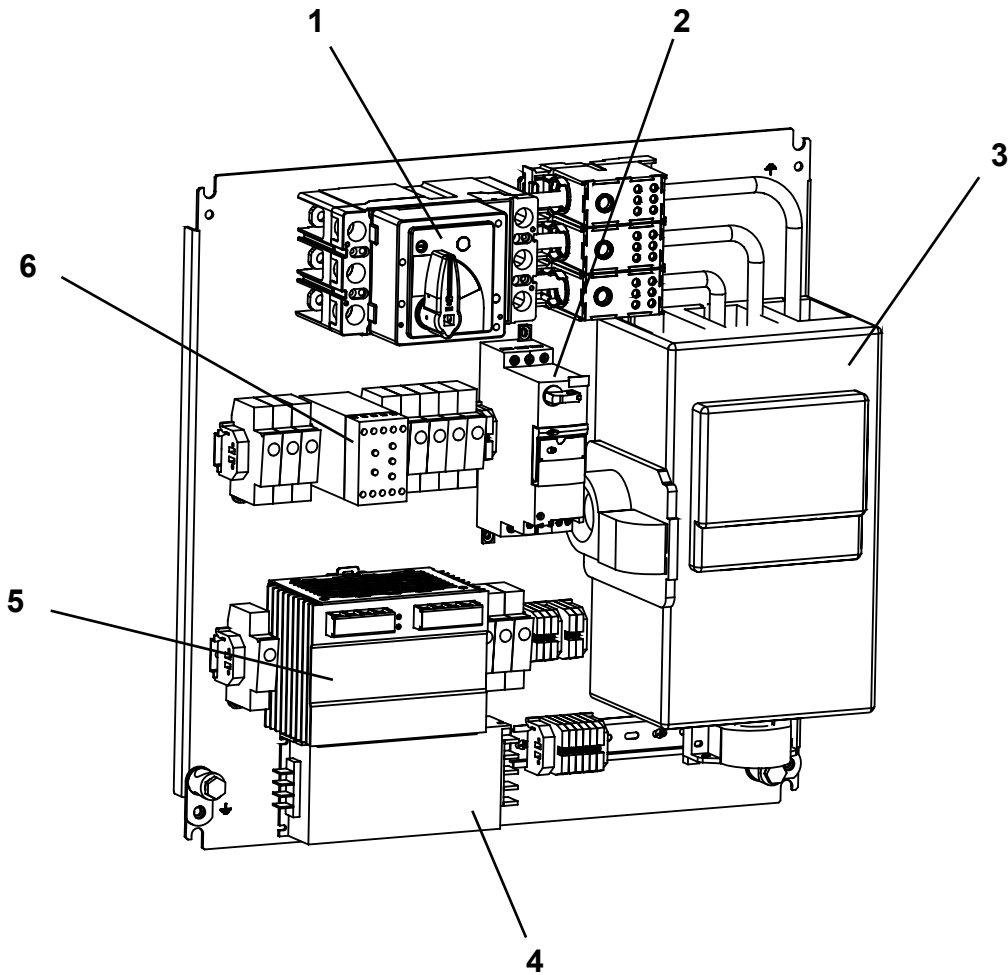

- 1. 480V/400V Main Power Disconnect Switch
- 2. 1.5 HP Cooling Fan Breaker
- 3. 100 HP Motor Soft Starter

- 4. 24V to 12V Power Converter
- 5. 24V Power Supply
- 6. Phase Detector

## **NOTES**

# Controls & Instruments

## P100E POWER PACK CONTROLS

The P100E power pack provides hydraulic power for the jacking frame and tooling components. The 100 HP electric motor drives dual independent load sensing, variable volume, and torque limiting piston pumps.

The hydraulic hoses are stored on hose reels for ease of routing hoses to jacking frame

The hoses are connected to the GBM hydraulic connections as follows:

- A – Return Hydraulic Hose Connection
- B – Case Drain Hydraulic Hose Connection
- C – Thrust Pressure Hydraulic Hose Connection
- D – Rotation Pressure Hydraulic Connection
- E – Thrust Load Sense Hydraulic Hose Connection
- F – Rotation Load Sense Hydraulic Hose Connection

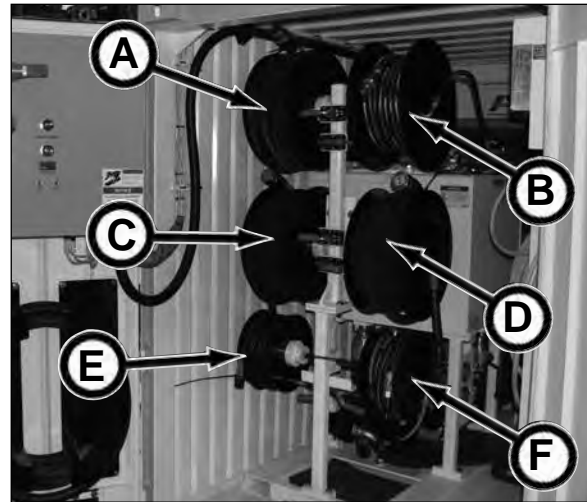

### Hydraulic Pressure Gauges & Adjustment Valves

Use the pressure gauges to monitor the GBM jacking thrust (G) and rotation (H) pressures.

Operating range is up to 4,000 psi (27.579 mPa).  
Maximum pressure is 5,000 psi (34.474 mPa).

The pressure adjustment valves are factory set at 5,000 psi (34.474 mPa). If your pipe has a lower thrust load pressure rating, use adjustment valve (I) to adjust the pressure to protect the product pipe. To adjust the pressure, refer Adjusting Jacking Pressure in Operation section. The rotation adjustment valve (J) should not be adjusted.

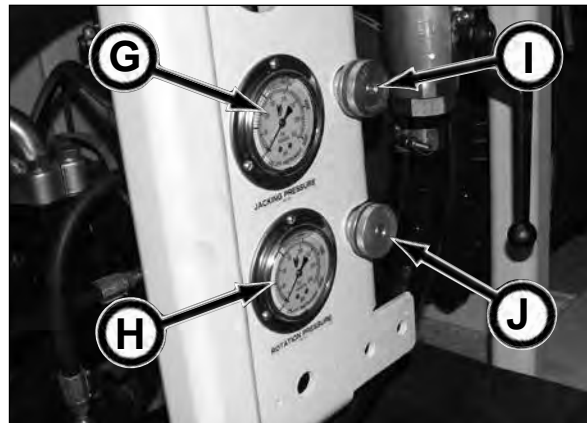

### Container Light Switch (K)

### Oil Fill Power Switch (L) & Oil Fill Pump Switch (M)

Flip power switch (L) ON to provide power to the Oil Fill switch in the container. Flip oil pump switch (M) up to pump hydraulic oil into the hydraulic reservoir. Once reservoir is full, be sure to flip both power and fill pump switches to the off position.

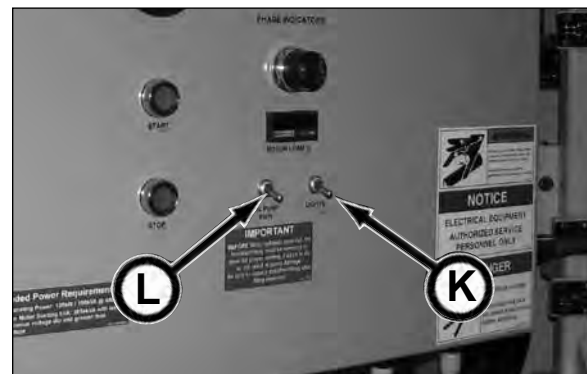

**IMPORTANT: BEFORE** filling hydraulic reservoir, the breather/fitting must be removed to allow for proper venting. Failure to do so will result in pump damage. Be sure to replace breather/fitting after filling reservoir.

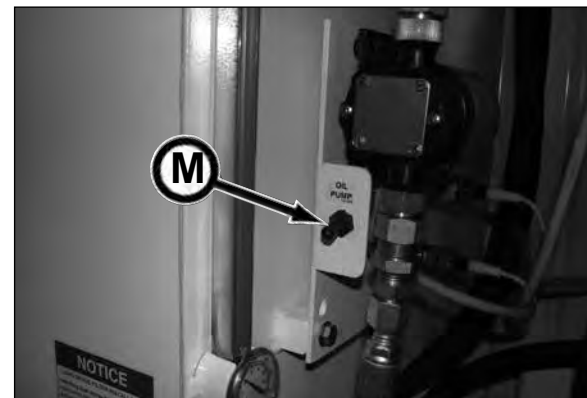

*(continued on next page)*

## POWER PACK CONTROLS (continued)

### Hydraulic Return Filter Indicators (A)

To prevent under or over servicing of the hydraulic filter elements, filter indicators have been installed in your GBM Power Pack.

The green OK zone indicates that the filter is functioning properly. The yellow zone indicates that the filter will soon require replacement.

Replace return filter when the needle on the gauge is in the red CHANGE zone (see 4. Check Hydraulic Return Filter Indicators in Periodic Maintenance section).

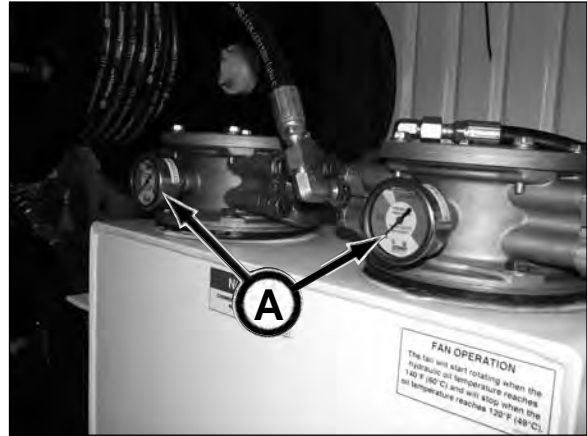

### Emergency Stop

The Emergency Stop button (B) on the P100E is located on the control panel.

Push Emergency Stop button IN to stop all electrical and hydraulic functions.

The button will light when it is pulled OUT.

This button must be pulled out to restart motor.



## CONTROL PENDANT - P100E

The control pendant allows the operator in the launch shaft to control the power pack motor for the hydraulic operation of the jacking and rotation systems.

There is also a port to connect the 12V guidance system power.

### NOTICE

The stop button will stop the 100 HP electric motor in the power pack. The stop button is NOT an emergency stop button. The E-Stop button on the control panel must be pulled out for motor to start.

### Jacking & Rotation Hydraulic Systems

Depress Start button (C) to start 100 HP electric motor and depress Stop button (D) to stop motor.

### Guidance System

The 12V connection (E) is equipped to supply power to the 12V guidance system. The main power must be on for power to this connection. The E-Stop does not affect the power to the guidance system.

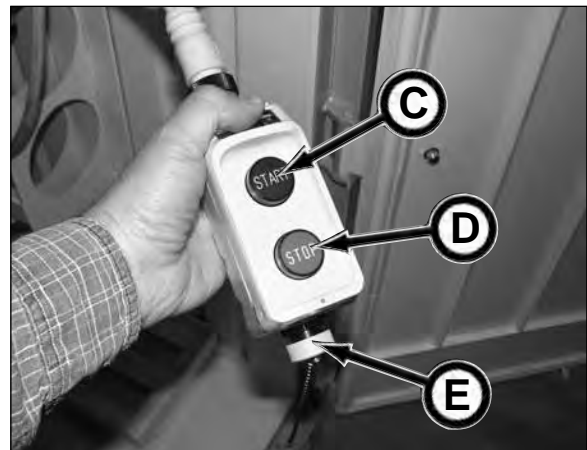

### NOTICE

The Panel/Pendant Control Power Switch must be in the Pendant Control position for the the pendant Stop and Start buttons to function. The guidance system power is not affected by the panel/pendant control power switch.

## PHASE INDICATORS

**⚠ DANGER** Failure to lockout tagout power before servicing will cause severe personal injury or death.

LOCKOUT TAGOUT main power supply before servicing. Electrical repairs must be performed only by a certified electrician.

Any electrical work completed on the power pack must be performed by a certified electrician.

The input power is monitored for proper three phase electrical power.

If the green Phase OK Indicator light (A) is illuminated, this indicates that the external power source phase power is installed correctly and that the main power can be turned on for the power circuit.

If the red Phase Error Indicator light (B) is illuminated at start-up, this typically indicates that the external power source phase power is installed incorrectly and will not allow power to any of the electrical components. Disconnect and lock out ALL power before attempting to reverse the two generator power leads.

**IMPORTANT: DO NOT start up electric components if the red phase indicator light is illuminated. Doing so will run components backwards causing damage.**

The red Phase Indicator light will also illuminate in the following conditions:

- Undervoltage (less than 95%)
- Overvoltage (greater than 110%)
- Phase imbalance
- Phase loss

If this should occur, contact a certified electrician to troubleshoot the fault by accessing the phase detector. The phase detector is equipped with a LED status light to help determine the fault. Refer to the table to the right for the Phase LED status fault indicator codes.

The LED status light (C) is located on the inside of the control panel.

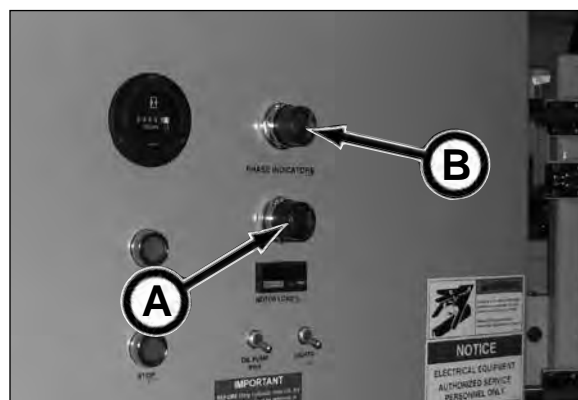

FAULT INDICATION CODE TABLE	
Led Status	Indicator
Green Steady	Normal / Relay ON
Green Flashing	Power Up / Restart Delay
Red Steady	Unbalance
Red Flashing	Under Voltage / Overvoltage
Amber Steady	Reversal
Amber Flashing	Loss
Green/Red Alternating	Under / Overvoltage Trip Pending
Red/Amber Alternating	Nominal Voltage Set Error

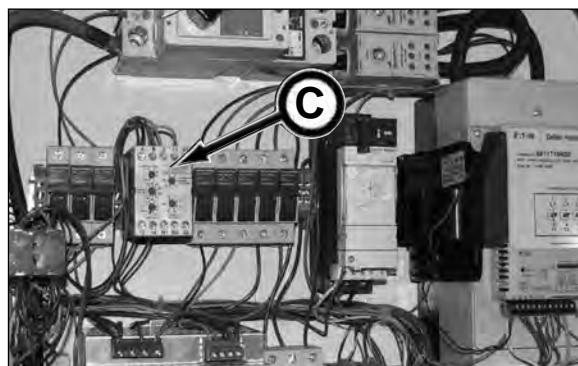

## LIGHTS

The power pack is equipped with two operating lights (A).

Flip light switch (B) as follows:

Lights ON - UP

Lights OFF - DOWN

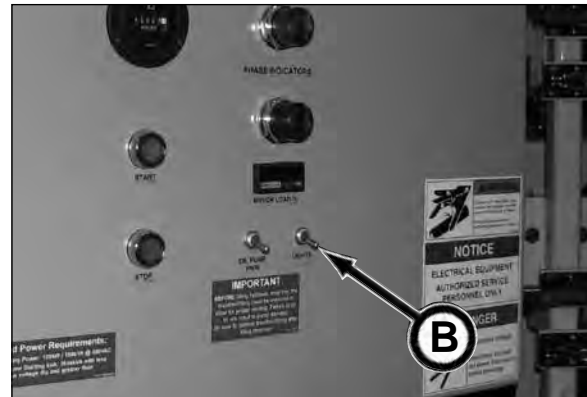
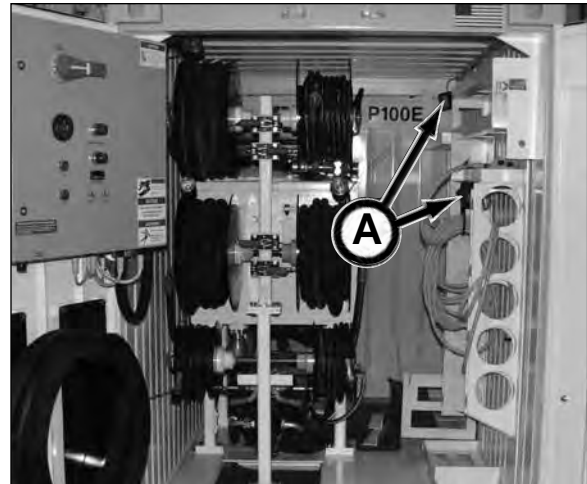

## MOTOR LOAD %

The Motor Load % display (C) indicates the 100 HP electric motor full load amperage in %.

The electric motor will operate as follows:

- 100% continuous operation
- 115% intermittent operation
- over 115% operation may result in the hydraulics and motor overheating resulting in the motor thermal overload to trip. In this case the motor will remain inoperable until the prescribed cool-down time has elapsed.

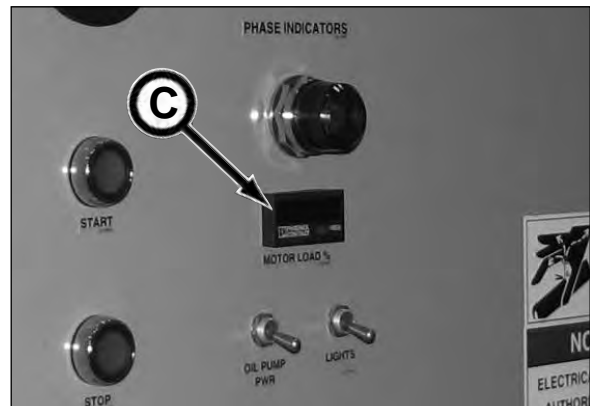

## OIL COOLER FAN

**⚠ WARNING** Serious personal injury could result if contact is made with rotating fan blade. Fan blades can rotate at any time power is connected and the main disconnect is in the ON position.

If the power is connected to the power pack and the main disconnect is in the ON position, the fan can rotate anytime the hydraulic oil is at 120°F (49 °C) (factory default setting).

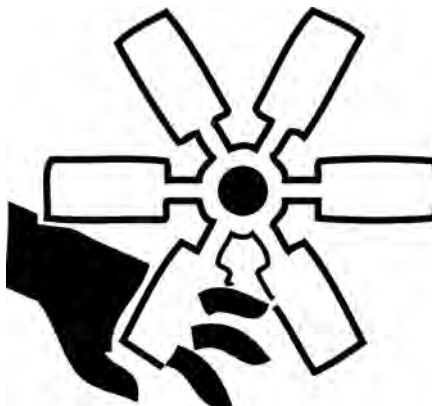

The oil cooler fan (A) is equipped with a temperature control.

When the hydraulic oil tank temperature reaches 140°F (60°C), the oil cooler fan motor will automatically start and will stop once the oil temperature is below 120°F (49°C).

The Emergency Stop will override the temperature control operation.



## MOTOR HOURMETER

The 100 HP electric motor is equipped with an hourmeter (B).

The hourmeter displays the operating hours in full hours and 1/10ths hours of the motor and should be used as a guide for scheduling periodic maintenance.

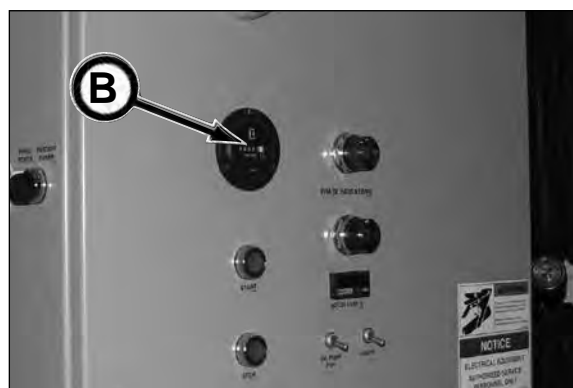

## **NOTES**

# Operation

You must read and understand this manual, the 240A, 308A and 339A Operator's Manual, and your electric motor Installation, Operation and Maintenance Instructions booklet before you operate and maintain this equipment.

---

## USING EMERGENCY STOP

The Emergency Stop button (A) on the P100E is located on the control panel.

Push Emergency Stop button IN to stop all electrical and hydraulic functions.

The button will light when it is pulled OUT.

This button must be pulled out to restart motor.



## CONNECTING POWER LEADS

### **⚠ DANGER**

Hazardous voltage.

This machine is powered by high voltage electricity.

Failure to lockout tagout power before connecting power leads or servicing will cause severe personal injury or death.

LOCKOUT TAGOUT main power supply before connecting power leads or servicing. ONLY a qualified and trained technician can operate this equipment. Electrical repairs must be performed only by a certified electrician.



1. Lockout tagout generator or other power source.
2. Turn power pack main disconnect (A) to the OFF position.

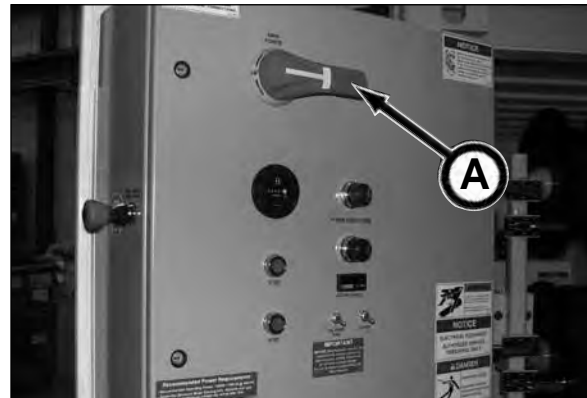

3. Uncoil power cable (B) and route cable through door flap (C).
4. Connect power pack power cable leads (D) to generator or other power source connection.
5. Turn on generator or other power source.
6. Turn main disconnect to the ON position.

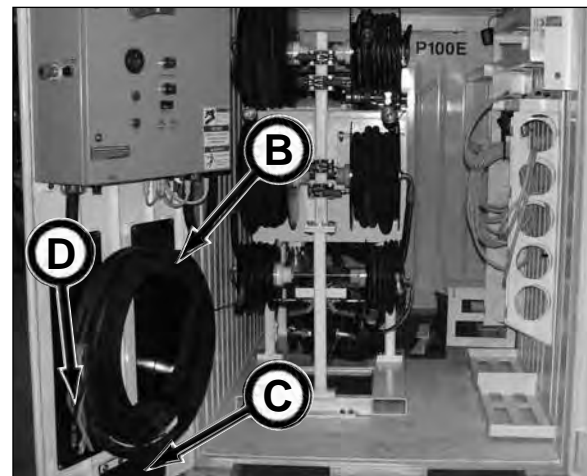

7. Check Phase Indicator lights. If green Phase OK light (E) is not illuminated, proceed to step 8, otherwise continue to step 9.
8. If red Phase Error light (F) is illuminated, a certified electrician must lockout tagout power source and turn power pack main disconnect to the OFF position. Then the electrician must reverse the two generator power leads. Repeat steps 5 - 7. For more information, refer to Phase Indicator in the Controls & Instruments section.

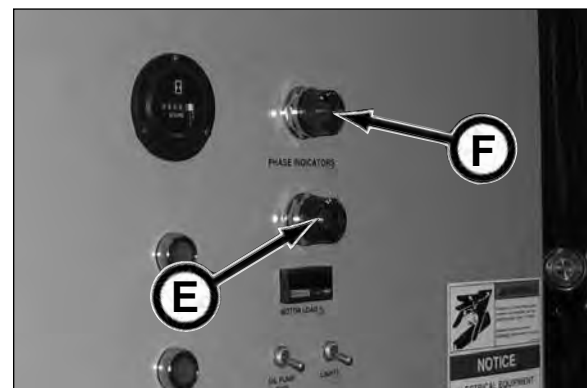

9. The electric motors are now available for operation.

## STARTING THE MOTOR

1. Once power is properly hooked up to power pack, the 100 HP motor (A) can be started either at the control panel or at the pendant control:

**NOTICE** The Emergency Stop button must be pulled out for motor to start.

### PANEL POWER

Turn Panel/Pendant Power Control switch to the Panel Power position (B).  
Depress start button (C) on control panel.

### PENDANT POWER

Turn Panel/Pendant Power Control switch to the Pendant Power position (D).  
Depress start button (E) on pendant control.

2. The jacking frame is now available for use.

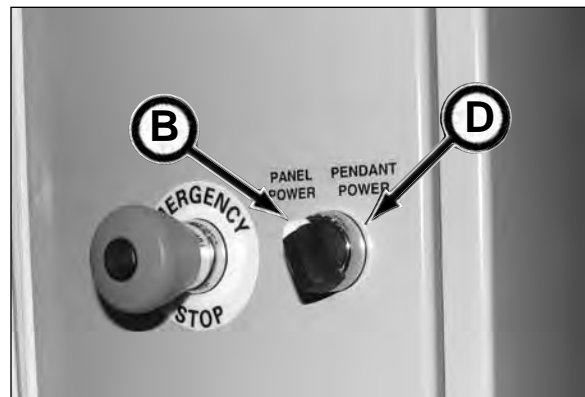
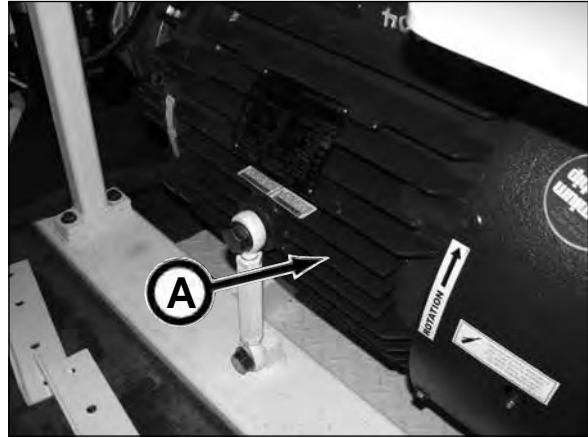

## STOPPING THE MOTOR

1. Depending upon whether you are using the control panel or the pendant to control the 100 HP electric motor, stop the motor as follows:

Control Panel: depress stop button (A)

Pendant: depress stop button (B)

2. Perform shutdown (refer to Daily Shutdown in this section).

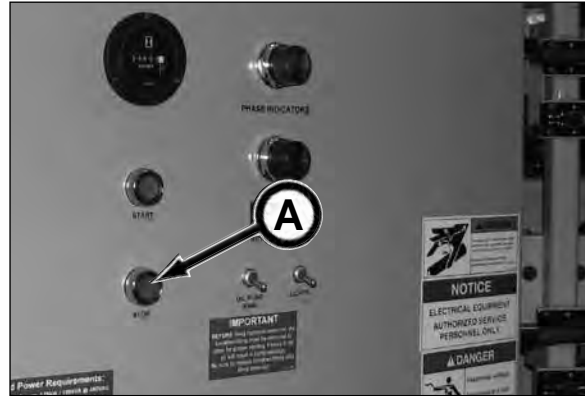

## CHECK HYDRAULICS AFTER MOTOR START-UP

**⚠ WARNING** Escaping oil or other fluids under pressure can penetrate your skin causing serious injury or death.

Release all pressure before performing maintenance or repairs, Never weld near pressurized fluid lines.

DO NOT use your hands to check for leaks. When searching for leaks, use a piece of wood or cardboard.

Contact medical help immediately if any oil or fluid is injected into your skin. A serious infection or reaction can emerge without proper medical treatment.



1. Check return filter indicators (C). Once operating temperature reaches at least 100°F (38°C) if the filter indicator needle is in the red CHANGE zone, replace filter.

2. Check hydraulic components and hoses for leaks. Repair or replace as needed.

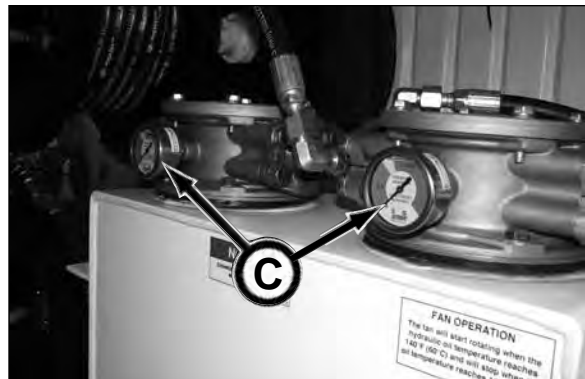

## ADJUSTING THRUST PRESSURE

### NOTICE

To protect your product pipe, you must be sure the product pipe rating can withstand the thrust pressure of the GBM. The P100E Power Pack maximum thrust pressure is 5,000 psi (100 ton). If your pipe is rated lower than 5,000 psi, the GBM thrust pressure **MUST** be adjusted. Failure to do so **WILL** break the pipe.

1. Check the thrust pressure rating for your product pipe.

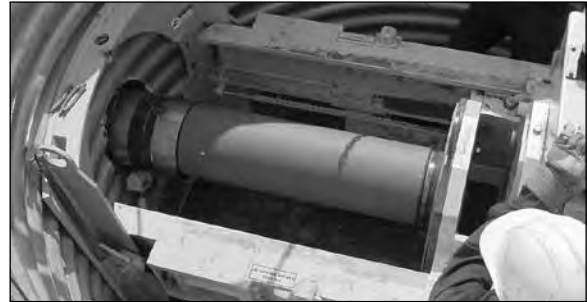

2. Calculate the pressure limit for your product pipe based on every 1000 psi is equal to 20 tons of thrust pressure. Or refer to the thrust pressure chart (to the right or the decal on the GBM).

GBM240				
PRESSURE PSI	CYLINDER LOAD IN TONS		DRIVE TORQUE IN Ft / lbs	
	EXTEND	RETRACT	LSHT	HSLT
250	4.9	2.5	499	197
500	9.8	5.0	998	393
750	14.8	7.5	1497	590
1000	19.7	10.0	1996	786
1250	24.6	12.5	2495	983
1500	29.5	15.0	2994	1179
1750	34.4	17.5	3493	1376
2000	39.4	20.0	3992	1573
2250	44.3	22.5	4491	1789
2500	49.2	25.0	4990	1966
2750	54.1	27.5	5489	2162
3000	59.1	30.0	5988	2359
3250	64.0	32.5	6487	2555
3500	68.9	35.1	6986	2752
3750	73.8	37.6	7485	2949
4000	78.7	40.1	7984	3145
4250	83.7	42.6	8483	3342
4500	88.6	45.1	8982	3538
4750	93.5	47.6	9481	3735
5000	98.4	50.1	9980	3932

3. With the power pack hydraulic hoses connected to the GBM and the power pack running, fully retract the GBM jacking cylinders by using the thrust cylinder control (A).
4. Check the thrust pressure on the thrust or jacking pressure gauge (B) on the GBM or power pack. Operating pressure is checked by retracting the jacking cylinders and holding lever after the cylinder base has stopped moving. Observe pressure on gauge.

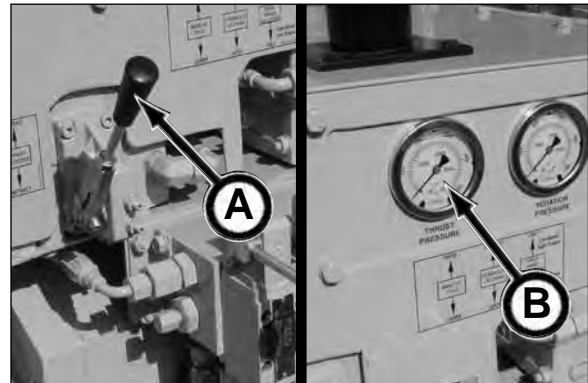

### NOTICE

Only a qualified service technician is allowed to perform pressure adjustments to the power pack.

If the pressure needs to be decreased, loosen lock collar (C) and turn adjustment dial (D) OUT. Once the pressure is properly adjusted, tighten lock collar.

If the pressure needs to be increased, loosen lock collar (C) and turn adjustment dial (D) IN. Once the pressure is properly adjusted, tighten lock collar.

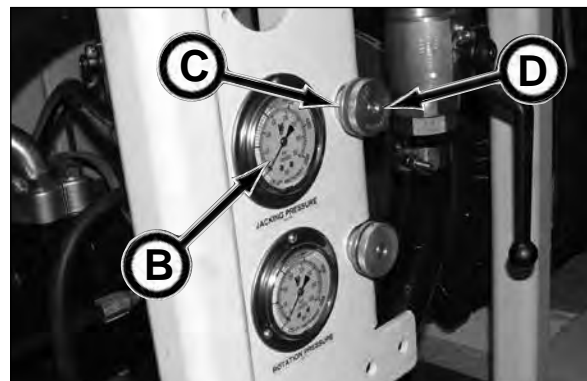

## FILLING THE HYDRAULIC OIL RESERVOIR

Check hydraulic tank oil level gauge (A).



If the fluid level in the reservoir is less than 3/4 full, fill the reservoir with ISO-VG Premium Hydraulic Oil (refer to hydraulic oil specification label on reservoir or Lubricants section in this manual) as follows:

1. Remove hydraulic fill hose (B) from storage location. Remove cap from hose.



2. Place hose into hydraulic oil container.

**NOTICE** Refer to Lubricants section for recommended hydraulic oil.



*(continued on next page)*

3. Open hydraulic fill shut off valve (A) by moving handle up to the 12 o'clock position.

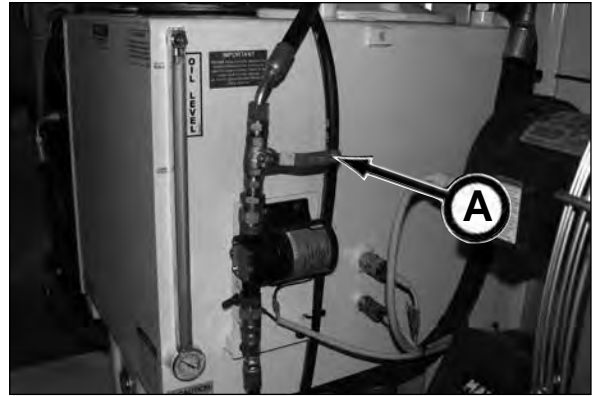

4. Flip Oil Fill Power switch (B) on the control panel to the ON position. This switch provides power to the Oil Fill switch in the container.



**IMPORTANT: BEFORE** filling hydraulic reservoir, the breather/fitting must be removed to allow for proper venting. Failure to do so will result in pump damage. Be sure to replace breather/fitting after filling reservoir.

5. Remove breather/fitting (C) from reservoir BEFORE filling reservoir to allow for proper venting during filling process.

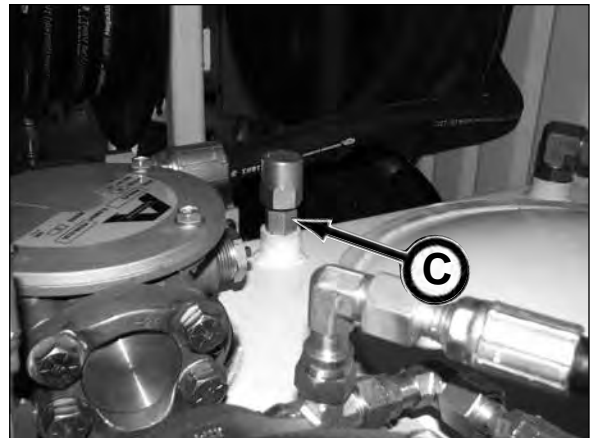

6. Flip Oil Fill Pump switch (D) in the container up to the ON position to pump hydraulic oil into the hydraulic reservoir.

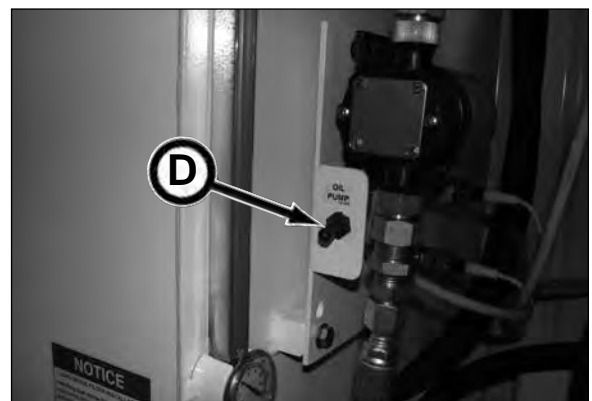

(continued on next page)

7. Fill until oil reaches the high mark on gauge (A).



8. Flip Oil Fill Pump switch (B) to the OFF position.

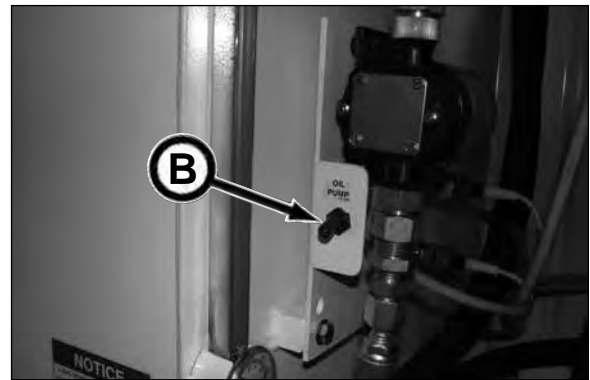

9. Replace breather/fitting (C) on reservoir.

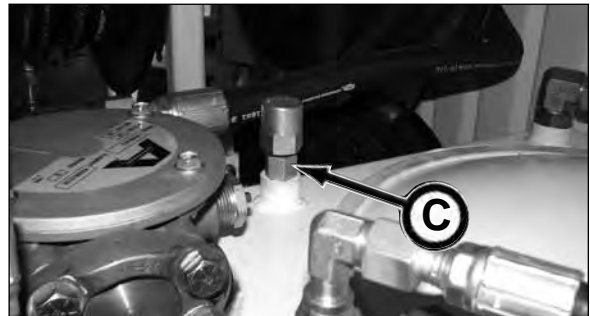

9. Close hydraulic fill shut off valve (D) by moving the handle down to the 3 o'clock position.



10. Flip Oil Fill Power switch (E) to the OFF position.

11. Replace cap on fill hose and place hose in storage location.



## DAILY SHUTDOWN

1. Shut off motor. Depending upon whether you are using the control panel or the pendant to control the 100 HP electric motor, depress the control pendant stop button (A) or the control panel stop button (B).



2. Turn main power disconnect (C) to OFF position.
3. Push IN E-Stop button (D).
4. Shut down generator or other power source and perform lockout/tagout procedure.

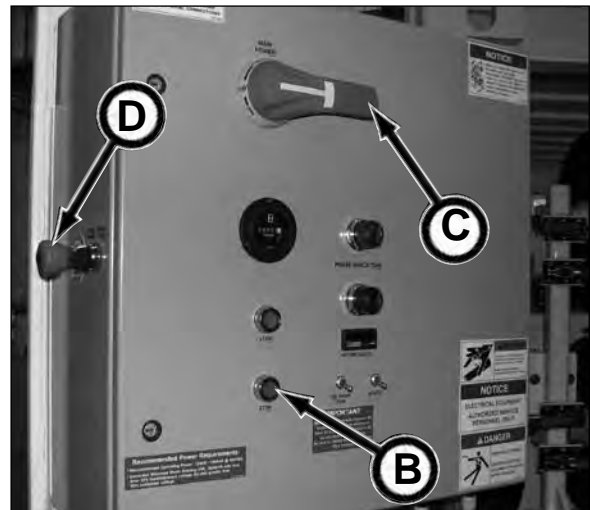

## **NOTES**

# Lubricants

## POWER PACK HYDRAULIC OIL RESERVOIR LUBRICANT

The power pack oil reservoir is filled with ISO-VG Premium Hydraulic Oil. Refer to hydraulic specification decal mounted on the reservoir for the oil fill.

Use an API GL-1/GL-2 or equivalent when adding or changing lubricant.

### NOTICE

If using a too heavy of viscosity oil in cold temperatures, hydraulic oil pump damage could result due to pump cavitation. On the contrary, using ISO 32 or 46 oils above 150°F operating temperatures (oil temp. in reservoir) will result in reduced hydraulic power to functions.

Recommended hydraulic oil:

Ambient Temp.	Hydraulic Oil
-25°F to 60°F (-32°C to 16°C)	ISO 32
0°F to 95°F (-18°C to 35°C)	ISO 46
32°F to 105°F (-0°C to 41°C)	ISO 68

### NOTICE

If you change to a different oil, use a reputable oil supplier to meet or exceed the ISO-VG or API GL-1/GL-2 oil specification. Do not mix oil manufacturers or grades.



## GREASE

The lubrication points are greased with Mobilgrease® XHP222 Premium Lubricating Grease.

The XHP222 grease is a multi-purpose, high performance, high temperature, lithium grease.

Use Mobilgrease® XHP222 Premium Lubricating Grease or equivalent when lubricating the lubrication points (A).

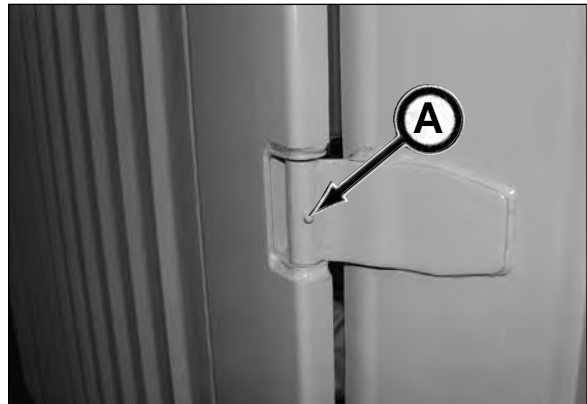

## STORING LUBRICANTS

Your equipment can operate at maximum performance only if clean lubricants are used. Use clean containers to handle all lubricants.

Lubricants should be stored in an area protected from dust, moisture, and other contaminants.



## **NOTES**

# Periodic Maintenance

**⚠ WARNING** Review the Safety section in this supplement and your 240A, 308A and 339A Operator's Manual before performing maintenance. Failure to do so, could cause severe injury or death.

## LUBRICATION & MAINTENANCE INTERVALS

The requirements for lubrication and maintenance are shown on the maintenance charts in this section. Intervals of maintenance are based on normal operating conditions. If operating under more difficult conditions, use a shorter time interval between maintenance.

Use the power pack motor hourmeter (A) to determine the proper lubrication and maintenance intervals.

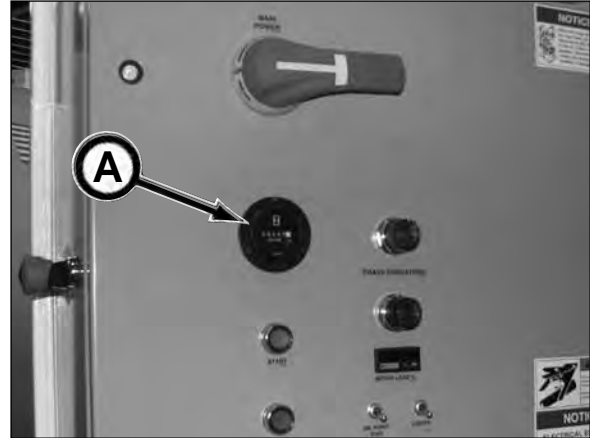

## LOCKOUT TAGOUT POWER BEFORE SERVICING

**⚠ WARNING** Severe personal injury or death can result from unexpected power pack start-up or machine movement.

LOCKOUT TAGOUT power before attempting to make repairs or adjustments to this equipment, unless otherwise indicated. Proper lockout tagout will prevent accidents and save lives. Performing the lockout tagout will also prevent the equipment from moving or operating unexpectedly.



## AVOID PINCH POINTS

**⚠ WARNING** Moving parts or the mishandling of parts can cause severe personal injury.

Keep hands away from moving parts.

Watch your fingers, hands, and legs while equipment is in operation.

Handle parts carefully to avoid crushing and pinch point hazards.



## USING EMERGENCY STOP

The Emergency Stop button (B) on the P100E is located on the control panel.

Push Emergency Stop button IN to stop all electrical and hydraulic functions.

The button will light when it is pulled OUT.

This button must be pulled out to restart motor.



## HYDRAULIC OIL/FLUIDS UNDER PRESSURE

**⚠ WARNING** Escaping oil or other fluids under pressure can penetrate your skin causing serious injury.

Release all pressure before performing maintenance or repairs. Never weld near pressurized fluid lines.

DO NOT use your hands to check for leaks. When searching for leaks, use a piece of wood or cardboard.

Contact medical help immediately if any oil or fluid is injected into your skin. A serious infection or reaction can emerge without proper medical treatment.



## MAINTENANCE CHART - P100E

Use the item number in the chart to refer to the detailed maintenance procedures later in this section.

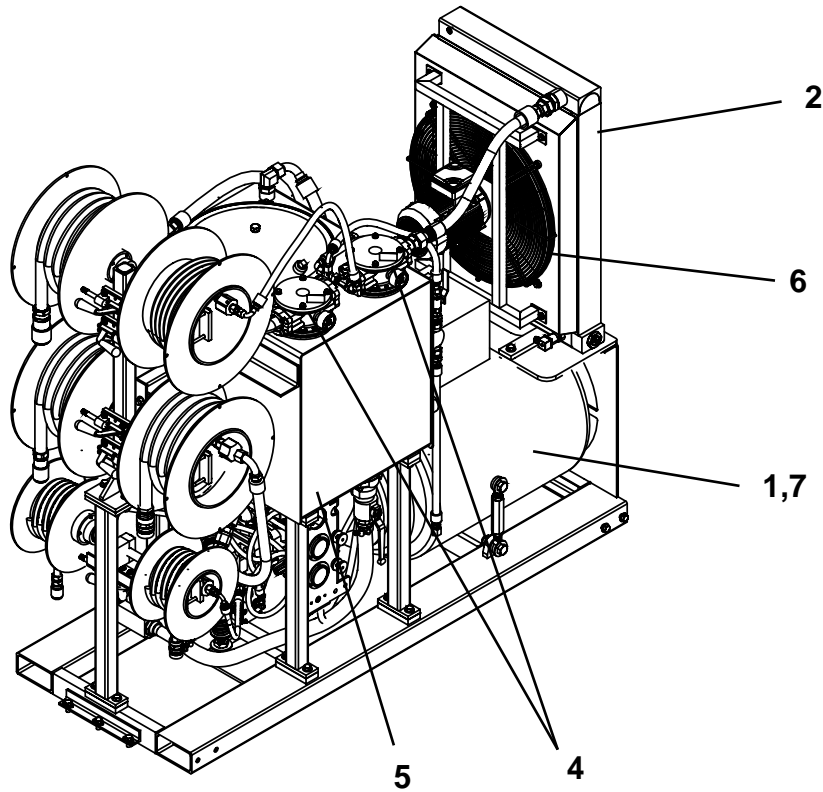

### ELECTRIC MOTOR MAINTENANCE

ITEM	COMPONENT	SERVICE	REQUIREMENT	MATERIAL
1.	Electric Motor	Maintenance	Per maintenance instructions	See Page 67

### PRIOR TO EACH JOB LAUNCH

ITEM	COMPONENT	SERVICE	REQUIREMENT	MATERIAL
2.	Oil Cooler	Clean	As needed.	

### \*DAILY OR EVERY 10 HOURS OF OPERATION

ITEM	COMPONENT	SERVICE	REQUIREMENT	MATERIAL
3.	Power Pack*	Visual Inspection	If parts are damaged or missing, replace.	
4.	Hydraulic Return Filters	Check Indicator	Replace filter as needed per indicator.	Return Filter
5.	Hydraulic Reservoir	Check Fluid Level	Add hydraulic fluid as needed.	See Page 37
6.	Fan	Inspect Fan	If damaged, replace with new.	

### WEEKLY OR EVERY 50 HOURS OF OPERATION

ITEM	COMPONENT	SERVICE	REQUIREMENT	MATERIAL
7.	Motor	Check	Ventilation openings clean and drain holes open.	

\* Not Shown  
gbmP100Eom-050100

**NOTICE**

Use the item number in the chart to refer to the detailed maintenance procedures later in this section.

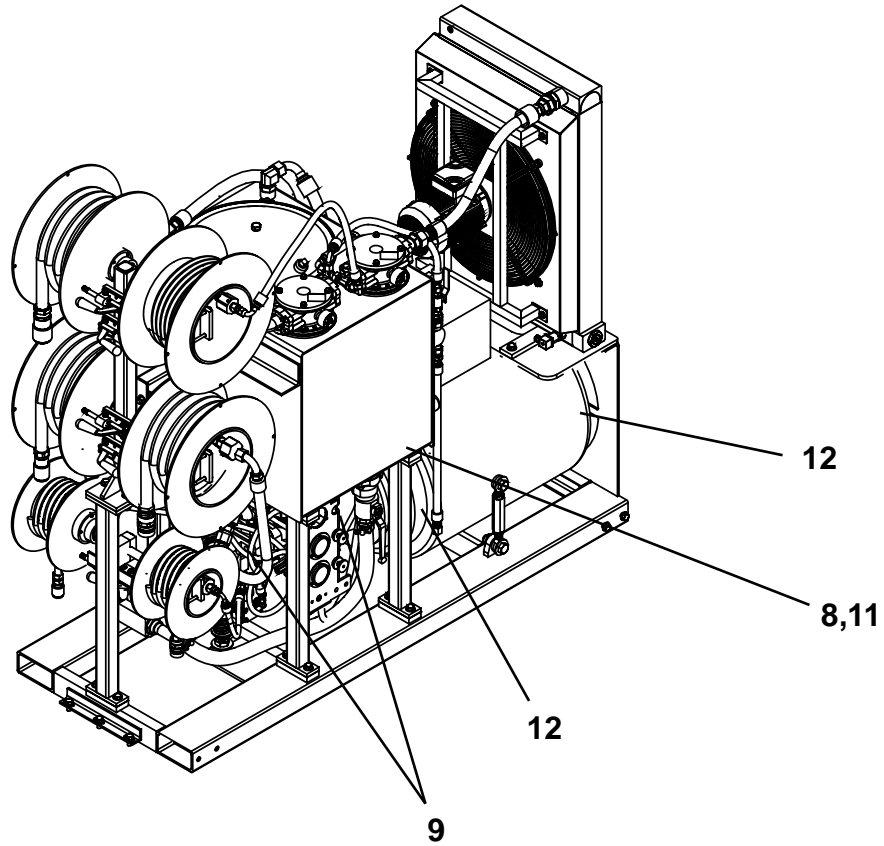

**COMPLETION OF EACH DRIVE**

ITEM	COMPONENT	SERVICE	REQUIREMENT	MATERIAL
8.	Hydraulic Reservoir	Drain water	Drain until water is removed.	

**\*EVERY 500 HOURS OF OPERATION**

ITEM	COMPONENT	SERVICE	REQUIREMENT	MATERIAL
9.	Load Sense Filters	Replace	Replace with new.	LS Filters
10.	Door Hinge*	Lubricate	2 Shots	Mobil XHP222

**\*EVERY 1000 HOURS OF OPERATION**

ITEM	COMPONENT	SERVICE	REQUIREMENT	MATERIAL
11.	Hydraulic Reservoir	Drain & Fill	Drain and fill with new oil.	See Page 37

**ANNUALLY**

ITEM	COMPONENT	SERVICE	REQUIREMENT	MATERIAL
12.	Electric Motor Brgs.	Lubricate (2 places)	2 Shots	Mobil Polyrex EM

\* Not Shown

---

## ELECTRIC MOTOR MAINTENANCE

### 1. ELECTRIC MOTOR MAINTENANCE

Perform maintenance on each motor as defined in the Installation, Operation and Maintenance Instructions section, starting on page 67.

The motors require inspection of the ventilation openings and lubrication of the motor bearings per the manufacturer's instructions.



---

## PRIOR TO EACH JOB LAUNCH

### 2. CLEAN OIL COOLER

1. Open rear door on power pack to gain access to the oil cooler (A).
2. Clean oil cooler with compressed air (100 psi maximum).

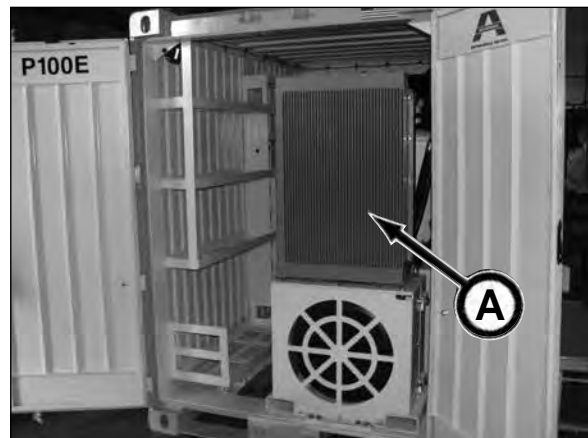

## DAILY OR EVERY 10 HOURS OF OPERATION

### 3. VISUALLY INSPECT EQUIPMENT

Perform a visual inspection of the power pack. Inspect structures, mountings and lubricant levels.

Immediately report any structural problems to your Akkerman aftermarket support representative.

Check for oil leaks and debris buildup. Make repairs as needed and remove debris.

Check for loose, damaged, or missing parts. Repair or replace as necessary. Replace any defective parts.

Tighten hardware as needed. Do not over-tighten hardware.



### 4. CHECK HYDRAULIC RETURN FILTER INDICATORS

To prevent over or under servicing of the hydraulic return filters, a filter indicator (A) has been installed on both hydraulic return filter housings.

Always check gauges when the oil is at normal operating temperature and the system is at normal operating flow. Otherwise, the gauges may indicate a false reading.

All filters and oil require replacement if any of the following situations occur:

- A major component fails.
- Any sign of water contamination from an oil analysis or if oil is milky or foaming.
- A hydraulic oil sample indicates large particle contamination.

The green OK zone indicates that the filter is functioning properly.

The yellow zone indicates that the filter will soon require replacement.

When the needle on the gauge is in the red CHANGE zone, replace filter as soon as possible to prevent hydraulic component damage (see Replacing Filter below).

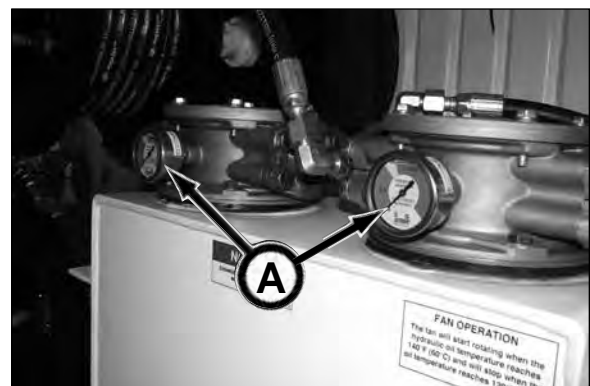

### REPLACING FILTER(S)

1. With power pack shutdown, clean and dry area around the filter head assembly.
2. Remove filter head fasteners and retain for later use.

*(continued on next page)*



3. Remove head assembly from housing.



4. Remove filter.
5. Check for metal flakes on filter. If metal flakes are visible, replace all filters and reservoir oil.
6. Dispose of filter properly.

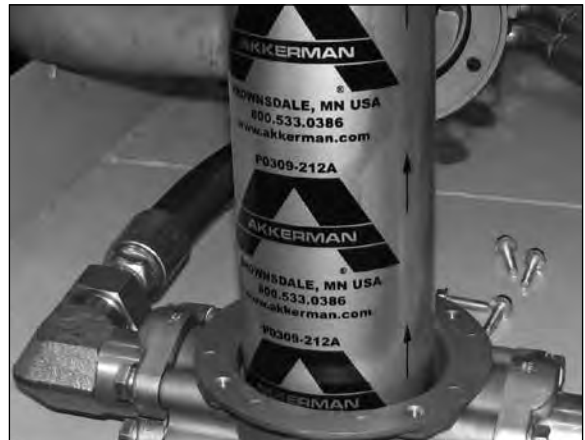

7. Check filter gasket in filter head. If worn or damaged replace with new. Install new gasket (if needed) with a light coat of clean hydraulic oil into filter head. Be sure the gasket is not twisted and is correctly in place.



8. Carefully install new filter into filter housing until it is fully seated into housing.

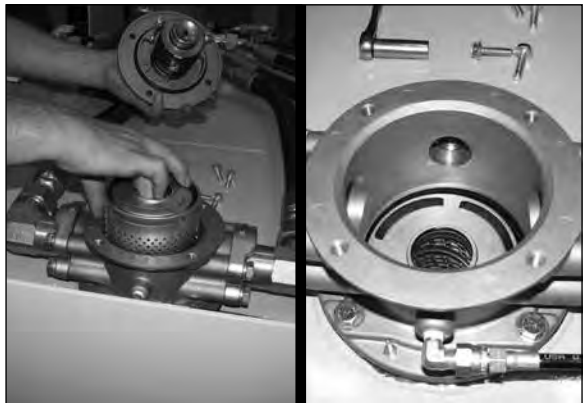

*(continued on next page)*

9. Replace filter head assembly onto housing and secure with fasteners removed in step 2.
10. Start up power pack and run until hydraulic system is warm, start boring head and jacking motors and check for leaks.
11. Stop motors and shutdown power pack. Replace other filter(s) as needed.

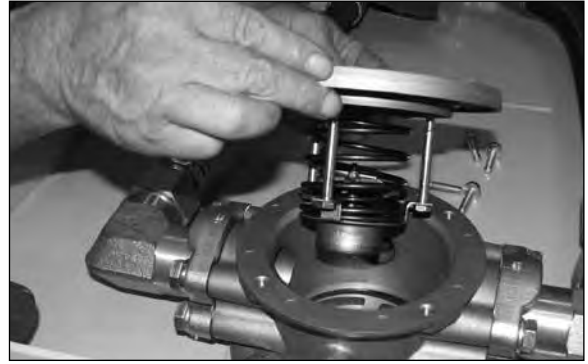

## 5. CHECK HYDRAULIC RESERVOIR OIL LEVEL & CONDITION OF OIL

1. Check reservoir hydraulic oil for the following:
  - a. Check for oil bubbles or foaming oil. This may indicate an air leak in the system.
  - b. Check for milky oil. This indicates that there is water in the system. Be sure your oil is being properly stored.
  - c. Large particle contamination from oil sample.

If any of these conditions are found, the reservoir must be drained, cleaned, and refilled with new, clean hydraulic oil and all hydraulic filters must be replaced. Refer to Every 1000 Hours of Operation, "9. Drain & Fill Hydraulic Oil" in this section.

2. Check hydraulic tank oil level gauge (A).

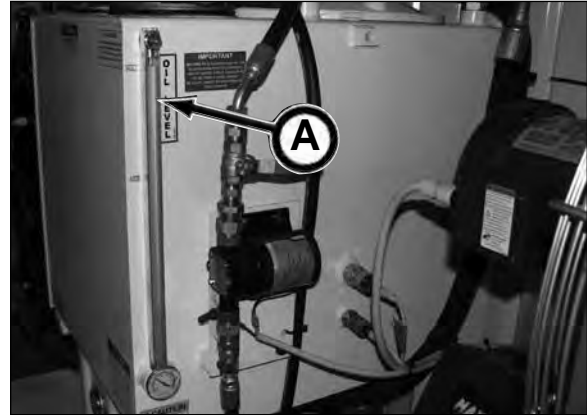

### FILLING RESERVOIR

If the fluid level in the reservoir is less than 3/4 full, fill the reservoir with ISO-VG-68 Premium Hydraulic Oil as follows:

1. Remove hydraulic fill hose (B) from storage location. Remove cap from hose.

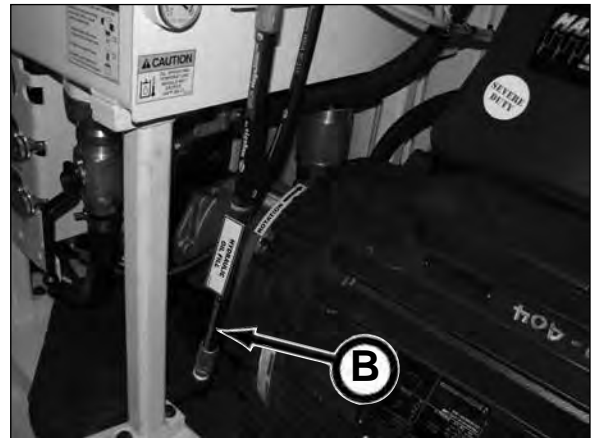

2. Place hose into hydraulic oil container.

**NOTICE** Refer to Lubricants section for recommended hydraulic oil.



(continued on next page)

3. Open hydraulic fill shut off valve (A) by moving handle up to the 12 o'clock position.

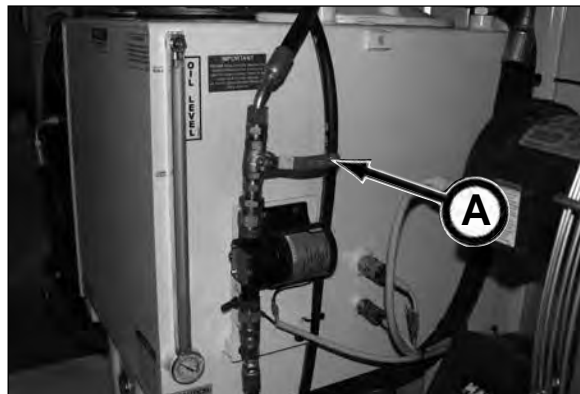

4. Flip Oil Fill Power switch (B) on the control panel to the ON position. This switch provides power to the Oil Fill switch in the container.



**IMPORTANT:** BEFORE filling hydraulic reservoir, the breather/fitting must be removed to allow for proper venting. Failure to do so will result in pump damage. Be sure to replace breather/fitting after filling reservoir.

5. Remove breather/fitting (C) from reservoir BEFORE filling reservoir to allow for proper venting during filling process.

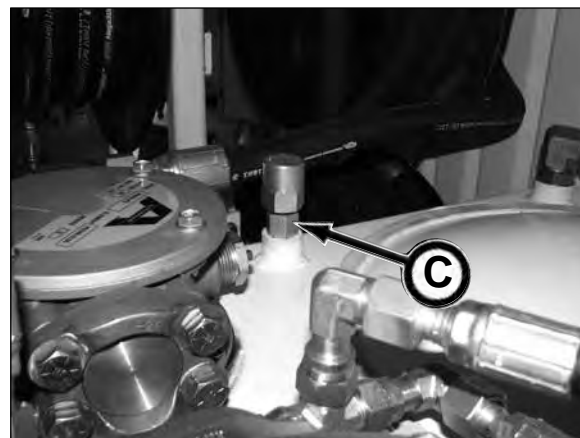

6. Flip Oil Fill Pump switch (D) in the container up to the ON position to pump hydraulic oil into the hydraulic reservoir.

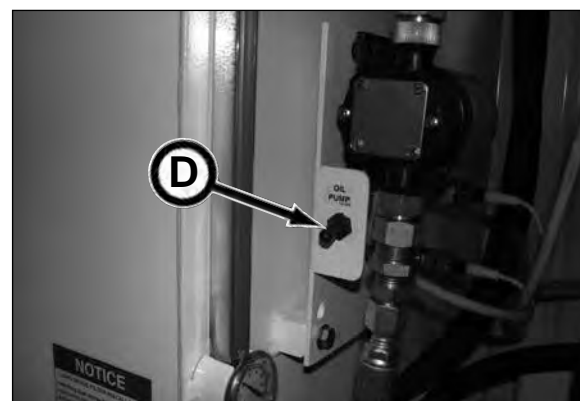

(continued on next page)

7. Fill until oil reaches the high mark on gauge (A).



8. Flip Oil Fill Pump switch (B) to the OFF position.

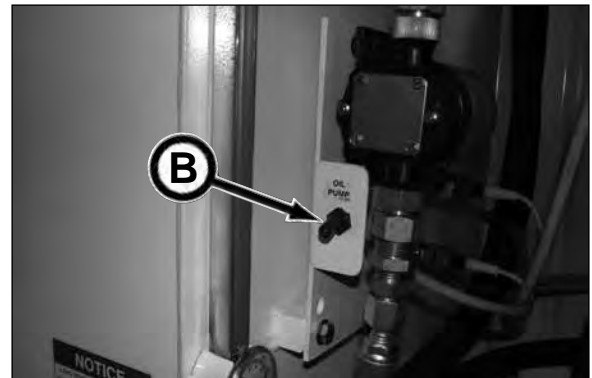

9. Replace breather/fitting (C) on reservoir.

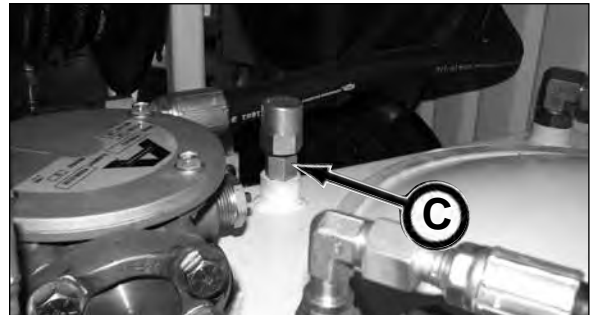

9. Close hydraulic fill shut off valve (D) by moving the handle down to the 3 o'clock position.



10. Flip Oil Fill Power switch (E) to the OFF position.

11. Replace cap on fill hose and place hose in storage location.



## 6. INSPECT FAN

**⚠ WARNING** Serious personal injury could result if contact is made with rotating fan blade. Fan blades can rotate at any time power is connected and the main disconnect is in the ON position.

If the power is connected to the power pack and the main disconnect is in the ON position, the fan can rotate anytime the hydraulic oil is at 120°F (49°C) (factory default setting) or someone turns the fan on manually.

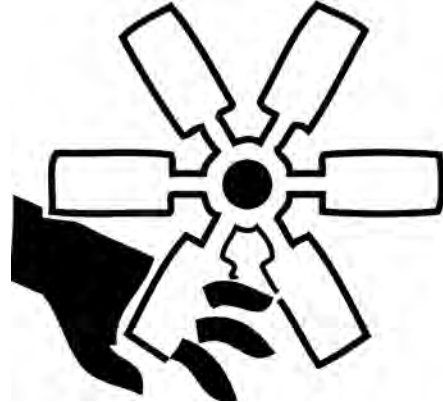

With the main disconnect in the OFF position and Emergency Stop pulled out to prevent accidental starting, check fan for cracks, and bent or loose blades. Replace damaged fan.



---

## WEEKLY OR EVERY 50 HOURS OF OPERATION

### 7. CHECK MOTORS

#### **NOTICE**

Refer to Electric Motor manual on page 67 for more information.

Inspect the ventilation openings of the 100 HP motor so they are clear to allow the free passage of air. Also, be sure the drain holes are open.

Use compressed air (maximum 50 psi) to clear openings.

Grease and oil can be removed from the motors with a petroleum solvent.



## COMPLETION OF EACH DRIVE

### 8. DRAIN WATER FROM HYDRAULIC RESERVOIRS

Remove water contamination from the hydraulic reservoir by draining water from the reservoir at the completion of each drive.

1. With pump unit on level ground, allow oil in hydraulic reservoir to settle overnight.
2. Remove plug (A) and slightly open tank drain ball valve (B) and drain (into a properly sized catch pan) until there is no water in oil.  
If desired to prevent drained fluids on pump unit components, install a 1/2" NPT hose to tank valve fitting and route hose to catch pan.
3. Once water is removed from tank, close tank drain ball valve, remove hose (if used) and reinstall plug.

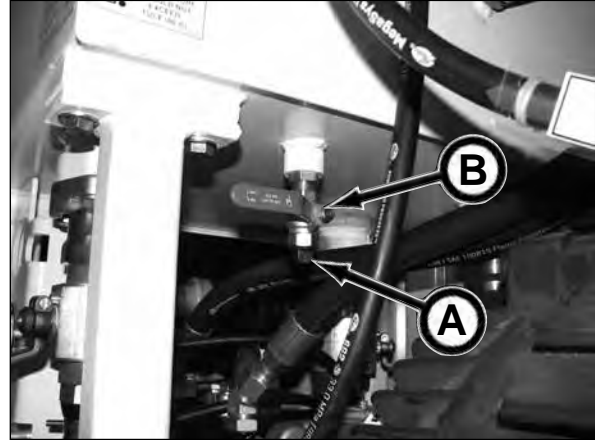

## EVERY 500 HOURS OF OPERATION

### 9. REPLACE LOAD SENSE FILTERS

The jacking pump load sense filter (A) and the rotation pump load sense filter (B) must be replaced at:

- 500 hours or yearly, whichever occurs first
- a major component fails
- any signs of water contamination
- hydraulic fluid sample indicates large particle contamination
- controls are sluggish

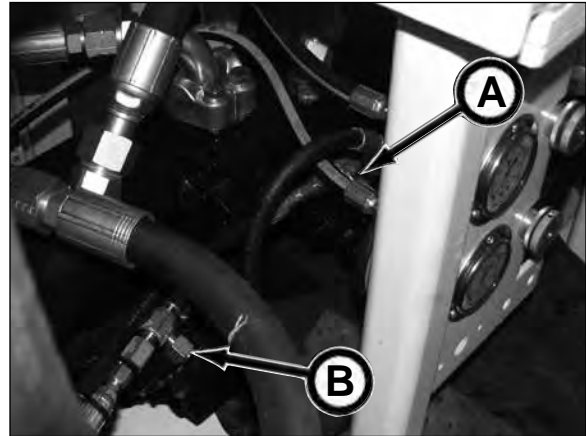

**NOTICE** Installing a load sense filter incorrectly, WILL cause pump malfunction.

1. Remove cap, spring, and filter from filter head.
2. Insert new filter (C) with nylon ring end (D) into filter head (E).
3. Place spring (F) into cap (G).
4. Install cap onto filter head. Tighten to 10 ft-lb (13.6 N-m) torque.

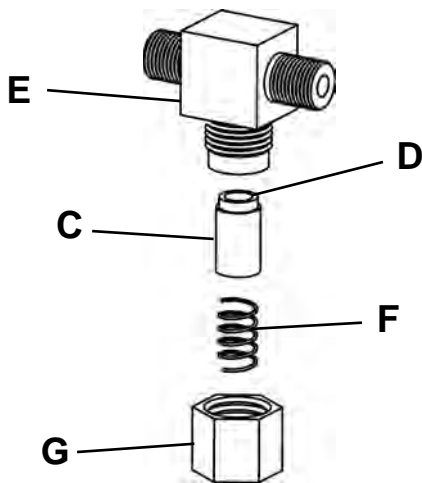
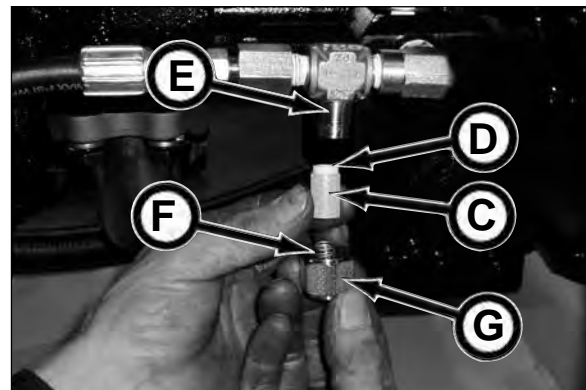

*Load Sense Filter Installation*



### 10. LUBRICATE POWER PACK DOOR HINGES

Lubricate the door hinges (H) with 2 shots of Mobilgrease® XHP222 Premium Lubricating Grease or equivalent.

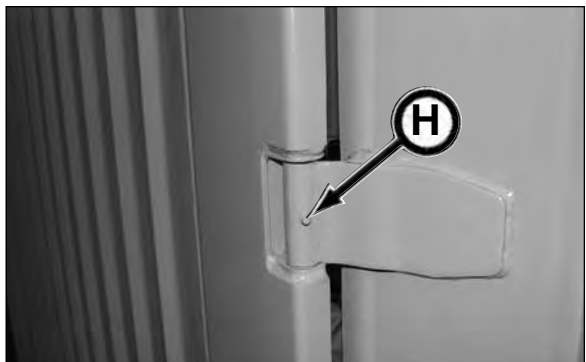

## EVERY 1000 HOURS OF OPERATION

### 11. DRAIN & FILL HYDRAULIC RESERVOIR

1. Drain oil into an appropriate sized catch pan or bucket as follows:

Remove plug (A) from ball valve (B) and install a 1/2 NPT hose to fitting. Open ball valve and drain oil. Close ball valve, remove hose and reinstall plug.

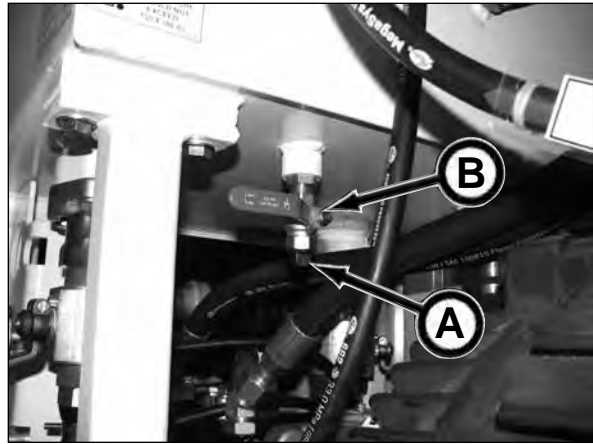

2. Remove hydraulic fill hose (C) from storage location. Remove cap from hose.



3. Place hose into hydraulic oil container or bucket.

**NOTICE** Refer to Lubricants section for recommended hydraulic oil.



4. Open hydraulic fill shut off valve (D) by moving handle up to the 12 o'clock position.



(continued on next page)

5. Flip Oil Fill Power switch (A) on the control panel to the ON position. This switch provides power to the Oil Fill switch in the container.



**IMPORTANT: BEFORE** filling hydraulic reservoir, the breather/fitting must be removed to allow for proper venting. Failure to do so will result in pump damage. Be sure to replace breather/fitting after filling reservoir.

6. Remove breather/fitting (B) from reservoir BEFORE filling reservoir to allow for proper venting during filling process.

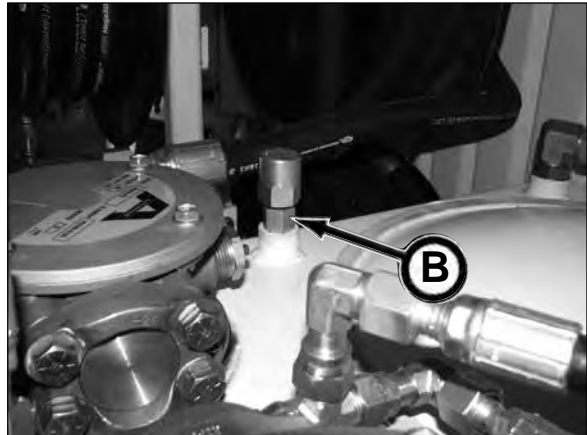

7. Flip Oil Fill Pump switch (C) in the container up to the ON position to pump hydraulic oil into the hydraulic reservoir.

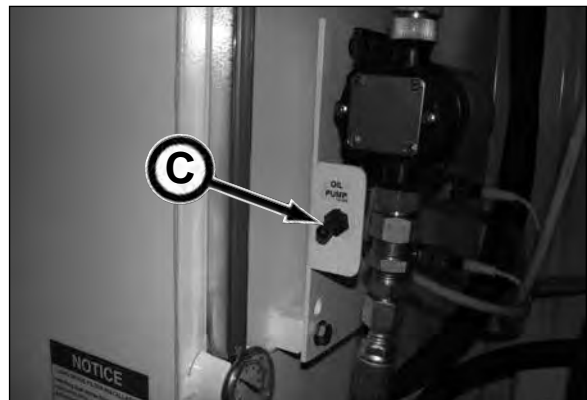

8. Fill until oil reaches the high mark on gauge (D).



(continued on next page)

9. Flip Oil Fill Pump switch (A) to the OFF position.

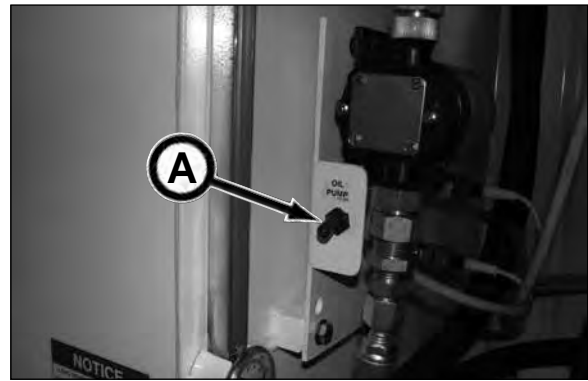

10. Replace breather/fitting (B) on reservoir.

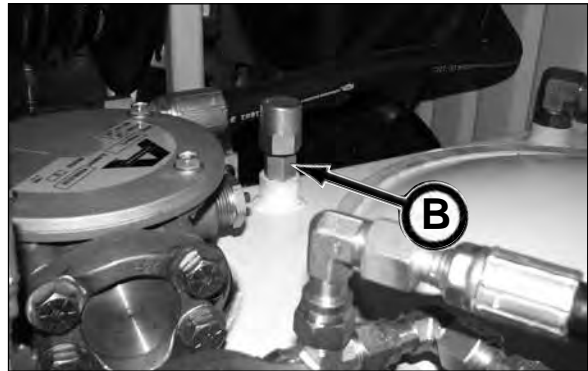

11. Close hydraulic fill shut off valve (C) by moving the handle down to the 3 o'clock position.



12. Flip Oil Fill Power switch (D) to the OFF position.

13. Replace cap on fill hose and place hose in storage location.



## ANNUALLY

### 12. LUBRICATE MOTOR BEARINGS

#### NOTICE

For additional electric motor maintenance information, contact your Akkerman Aftermarket Support representative.

Lubricate the electric motor bearings with two shots of Mobil Polyrex® EM grease or equivalent (refer to Grease Type below). There are two lubrication fittings (A) on the electric motor.

When adding lubricant, keep dirt out of the lubrication area. Wipe the fitting completely clean and use clean greasing equipment.

#### GREASE TYPE (unless nameplate states otherwise:

##### **Nameplate Ambient Temperature between -22°F (-30°C) to 150°F (65°C) inclusive:**

Recommended grease for standard service conditions is Mobil Polyrex® EM. Equivalent and compatible greases include: Texaco Polystar RB, Rykon Premium #2, Pennzoil Pen 2 Lube, Chevron SRI & Mobil SHC 100.

##### **Nameplate Ambient Temperature below**

**-22°F (-30°C):** Special low temperature grease is recommended such as Aeroshell 7 or Beacon 325 for ball bearings and Mobil SHC 100 for roller bearings.

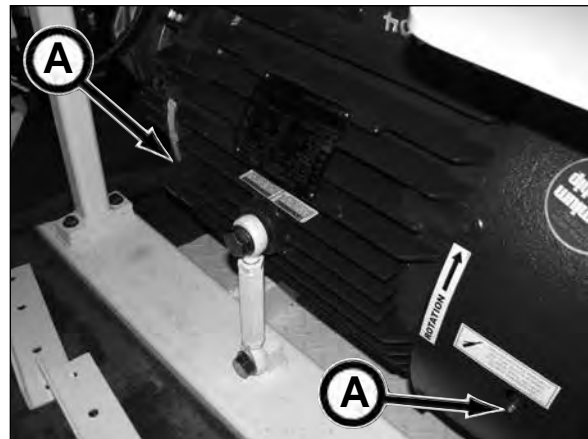

## **NOTES**

# Troubleshooting

**IMPORTANT:** Only a certified electrician can perform maintenance and troubleshooting on the P100E Power Pack electrical components.

## CONTROL PENDANT

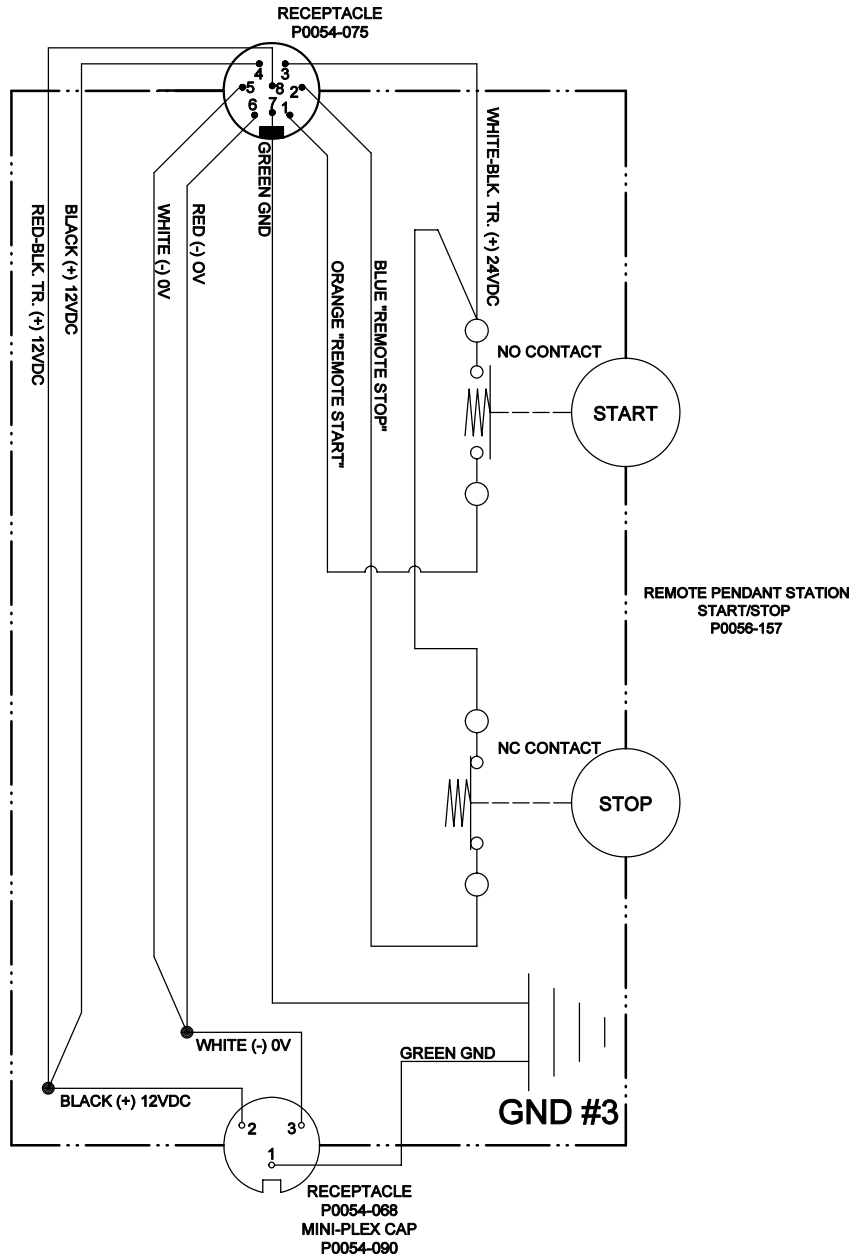





# ELECTRICAL MOTORS

Refer to troubleshooting for the electrical motors in the Installation, Operation and Maintenance Instructions booklet starting on page 67.

### 4.3.2 Motor Trouble-shooting Cause / Corrective Action - Table 4-5

Issue:	Likely Cause:	Corrective Action:
<b>Motor fails to start upon initial installation:</b>		
A.)	Supply voltage is too low or is severely unbalanced (one phase is low or missing).	(1) Check power supply fuses (2) Match motor lead wiring to nameplate connection diagram and supply voltage (3) Ensure that steady state supply voltage at motor terminals is within limits (see section 3.4.1.3). Correct as needed (4) Obtain correct motor to match actual supply voltage.
B.)	Motor leads are miswired at conduit box.	(1) Verify that motor & load turn freely (2) Disconnect motor from load & ensure motor turns freely. Note: Roller bearings make noise when motor is uncoupled and shaft is rotated (3) Verify that motor starts when disconnected from load (4) Remove excessive / binding load if present.
C.)	Driven load exceeds motor capacity.	(1) Verify that motor & load turn freely (2) Disconnect motor from load & ensure motor turns freely. Note: Roller bearings make noise when motor is uncoupled and shaft is rotated (3) Verify that motor starts when disconnected from load (4) Remove excessive / binding load if present.
D.)	Load is jammed.	Replace fan guard & fan if blades are damaged.
E.)	Fan guard is bent and making contact with fan.	Remove power factor correction capacitors if equipped.
F.)	VFD with power factor capacitors installed.	Ensure that motor neutral lead is ungrounded.
G.)	VFD with motor neutral lead grounded.	(1) Repeat checks listed above (2) Verify that VFD current limit and starting boost are set correctly (5) Double-check motor and feedback parameter settings and VFD parameters (6) Repeat walkline (for vector drives) procedure (7) Consult VFD supplier.
H.)	VFD programmed incorrectly.	
<b>Motor has been running, then slow down, stalls, or fails to restart:</b>		
A.)	Supply voltage has dropped or has become severely unbalanced.	(1) Replace fuse or reset circuit breaker. Allow motor to cool down before resetting manual protector on motor. Warnings - See section 1.1 for automatic and manual reset protector warnings (2) Verify that rated and balanced supply voltage has been restored before restarting motor. Measure voltage during restart. Ensure that steady state supply voltage at motor terminals is within limits (see section 3.4.1.3).
B.)	Motor is overloaded.	(1) Verify that motor & load turn freely. Recalibrate driving components as needed (2) Reduce driven load to match motor capacity or increase motor size to match load requirements.
C.)	Motor bearings are seized.	(1) Check fault codes on VFD and follow VFD troubleshooting procedures (2) Verify that VFD input voltage is calibrated and within limits (3) Remove excessive mechanical load if present.
D.)	Load is jammed.	Warning: Potential Shock Hazard! Contact service shop to check capacitor.
E.)	VFD will not restart motor after tripping.	
F.)	Capacitor failure on single phase motor (if equipped).	
<b>Motor takes too long to accelerate:</b>		
A.)	Motor leads are not connected correctly.	Match motor lead wiring to nameplate diagram.
B.)	Supply voltage has dropped or become severely unbalanced.	(1) Ensure that steady state supply voltage at motor terminals is within limits (see section 3.4.1.3). Correct as needed (2) Obtain correct motor to match actual supply voltage.
C.)	Load exceeds motor capability.	Determine correct motor size and re-configure motor.
D.)	Faulty start capacitor (Single Phase).	Motor may be too small for load. Record full acceleration time: exceeds 3 seconds.
E.)	Mechanical Failure.	(1) Check to make sure motor & load turn freely.

E.)	Motor is started too frequently.	See section 3.4.5.3.
F.)	Supply voltage too low, too high, or unbalanced.	(1) Ensure that steady state supply voltage at motor terminals is within limits (see section 3.4.1.3). Correct as needed (2) Reconnect motor per input voltage (3) Obtain correct motor to match power supply.
<b>Motor Vibrates</b>		
A.)	Motor misaligned to load.	Realign load.
B.)	Load out of balance (Direct drive application).	(1) Ensure that load is dynamically balanced (2) Remove motor from load and inspect motor by itself. Verify that motor shaft is not bent. Rule of thumb is 0.002" runout for shaft diameter lengths up to 3'00". Add 0.0002" per every additional inch of shaft length beyond 3'00".
C.)	Looseness/tension on multiple belts.	Mixing new with used belts. Replace multiple belt applications with a complete set of matched belts.
D.)	Driven load operating at resonant point / natural frequency.	(1) De-energize motor and record vibration as load coasts from 100% speed to 0 RPM. If vibration stops immediately, vibration source is electrical. If levels do not stop immediately, source is mechanical (2) Reconnect system to operate below the resonant point (3) On VFD-driven loads, program slip frequencies to bypass resonant points (4) Increase carrier frequency to obtain ~3% THD current (5) Use variable torque loads (reduce volts/hertz below base speed).
E.)	VFD torque pulsations.	(1) Adjust VFD to obtain <math>C_{THD}</math> current @ rated motor current (2) Adjust VFD stability for smooth operation. Vector drives may be unstable at light load.
F.)	Motor miswired at terminal box.	Match motor lead wiring to nameplate connection diagram.
G.)	Wires loose or loose mounting support.	Shim, strengthen or tighten where required.
H.)	Motor bearings defective.	Inspect motor by itself. If bearings are bad, you will hear noise or feel roughness. If roller bearings are normally noisy when operated without load. If sleeve bearings, add oil per nameplate instructions. For motors with greasing provisions, add grease per relubricating instructions (see section 4.2.3). If noise persists, contact warranty service.
I.)	Motor out of balance.	Disconnect from load. Set motor on rubber pads on solid floor. Secure a 1/4 height key in shaft evenly and engage from balanced power supply @ rated voltage. Record vibration levels and compare with appropriate standards. If excessive vibration persists, contact motor manufacturer.

Bearings repeatedly fail.		
A.)	Load to motor may be excessive or unbalanced.	(1) If belt drive, check system per section 3.3.4. (2) Other than belt, check loading on motor shaft. An unbalanced load will also cause the bearings to fail. (3) Check runouts of mating components, such as C-drive and pump flange.
B.)	Bearings contaminated.	Motor enclosure not suitable for environment. Replace with correct enclosure construction.
C.)	Improper grease or bearings for ambient extremes.	See section 4.2.1.
D.)	VFD bearing damage.	Ground trash common mode filter, or insulated bearings must be added. Contact motor manufacturer.

Motor, at start up, makes a loud rubbing, grinding, or squealing noise.		
A.)	Contact between rotating and stationary components.	Belt sagging during start-up is normal. (1) Verify that supply voltage is within limits (see section 3.4.1.3). (2) Ensure that motor lead wiring matches nameplate connection diagram (3) Isolate motor from load (4) To locate point of contact, turn motor shaft by hand. (5) If point of contact is not located, contact motor service shop.

Start capacitors repeatedly fail.		
A.)	The motor acceleration time is too long.	Motor may be too small for load. Record acceleration time. Start capacitors may fail if acceleration time exceeds 3 seconds.
B.)	Motor is being started too frequently.	Excessive starting will damage motor capacitors. Contact motor manufacturer if motor is started more than 20 times/hour or if acceleration time exceeds 3 seconds.
C.)	Motor voltage low.	Verify that voltage at the motor terminals is within limits (see section 3.4.1.3).
D.)	Defective start switch on motor.	Motor internal switch failure overtests start capacitor. Contact service shop or motor manufacturer.

Run capacitor fails.		
A.)	High ambient temperature.	Verify that the ambient does not exceed motor's nameplate value.
B.)	Input voltage exceeds limit.	Verify that voltage to the motor terminals is within limits (see section 3.4.1.3).
C.)	Power surge to motor (caused by lightning strike or other high transient voltages).	(A common problem). Install surge protector.

# P100E HYDRAULIC SCHEMATIC

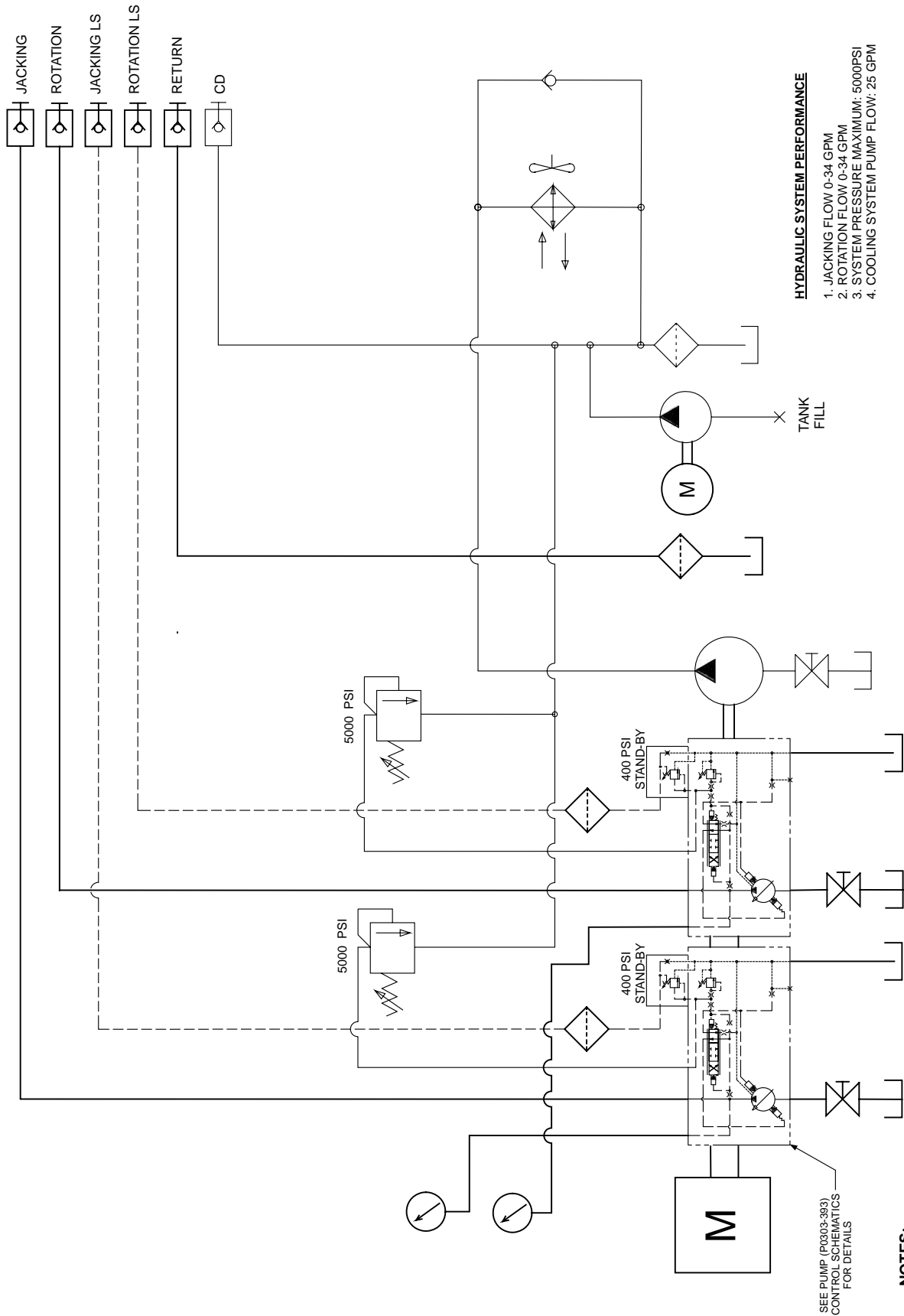

## **NOTES**

# Specifications

## P100E FEATURES & SPECIFICATIONS

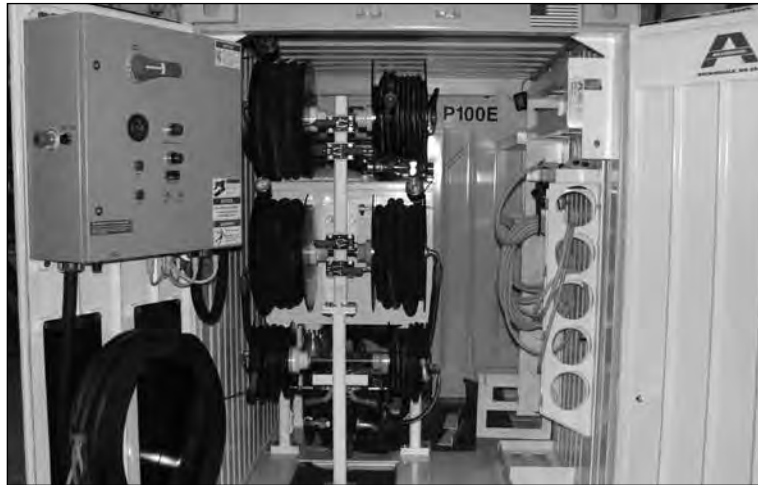

### FEATURES

- Assembly comes complete with the GBM P100E Power Pack, remote control pendant, 50 foot hydraulic hose set to connect hoses from the power pack to the GBM 240A/308A/339A jacking frames, & standard tooling for pilot tube installation.
- Standard tooling includes: pilot tube breakout tool, pilot tube scraper, pilot tube to reaming head adapter, steering head kit, pilot tube support bars, guidance system, wrench set, and launch shaft breakout tool
- Access doors on both ends provide a walk-through tooling storage area.
- Two pump system for independent operation of the jacking and rotation circuits.
- Powered by one 100 HP electric motor.
- Two load sense, variable volume piston pumps provide smooth efficient operation.
- Remote control pendant with 50 feet of cable controls the motor functions in shaft.
- Hydraulic hoses are stored on hose reels for ease of hose routing to jacking frame.
- Quick coupler connections with lock for easy and secure hydraulic hoses at jacking frame.
- The 20 gpm cooling circuit maintains hydraulic oil at low operating temperatures.
- Hydraulic pressure gauges for monitoring jacking, rotation system pressures.
- Equipped with E-Stop control at the operational end of container.

### SPECIFICATIONS

#### Dimensions

Height .....	82 in. (2,083 mm)
Width .....	58 in. (1,473 mm)
Length .....	96 in. (2,438 mm)

Weight ..... 7,000 lbs. (3,175 kg)

#### Fluid Capacities

Hydraulic Reservoir ..... 56 gal (212 L)

Power Source ..400V/460V, 3 Phase, Type TFS Motor

Electric Motor ..... 100 HP (75 kW)

#### Recommended Power Requirement

480V ..... 125kW / 150kVA @ 480VAC

400V ..... 125kW / 150kVA @ 400VAC - 60Hz

#### Generator Minimum Motor Starting kVA

385skVA with less than 35% instantaneous voltage dip and greater than 90% sustained voltage

#### Pumps

Variable Piston

Jacking ..... 0 to 30 gpm (0 to 114 L/min)

Rotation ..... 0 to 30 gpm (0 to 114 L/min)

Operating Pressure\* ..... 5,000 psi (34,475 kPa)

Gear Pump (Cooling) ..... 20 gpm (76 L/min)

\* Maximum

#### Breakout Tool

Breaking Torque 12,000 ft-lbs (16,272 N·m)

Power Source ..... 110 VAC

#### Pilot Tube/Reaming Head Adapter

.....4.15" OD x 3" ID Hex Core x 5" OD

## RELAY SETTINGS

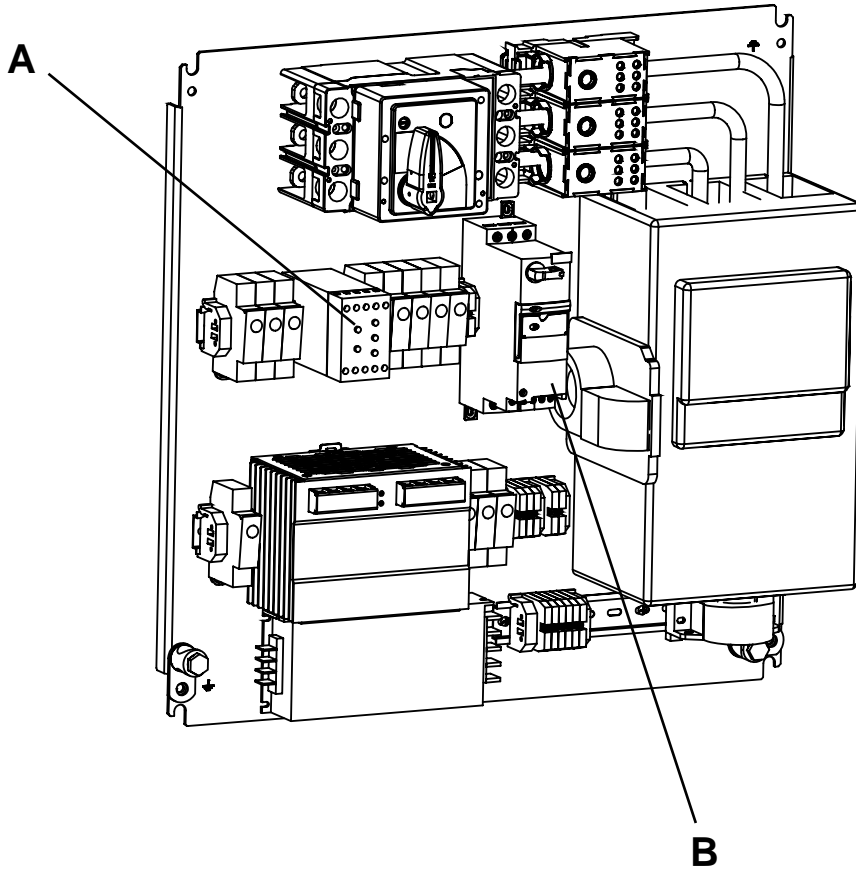

### Phase Check Relay (A)

Undervoltage .....	90%
Nominal Voltage .....	480/400
Unbalance .....	10%
Time Delay Undervoltage (Seconds) .....	0.1
Time Delay Restart (Seconds) .....	1

### Cooling Fan Overload Relay (B)

FLA .....	2.5 (480V) / 3.0 (400V)
-----------	-------------------------

# Installation, Operation and Maintenance Instructions for AC Induction Motors



**INSTALLER: PLEASE LEAVE THIS MANUAL FOR THE OWNER'S USE  
OWNER: READ AND SAVE THESE INSTRUCTIONS**

## **SAFETY INSTRUCTIONS**

**▲ This is the safety alert symbol. It is used to alert you to potential personal injury hazards. Obey all safety messages that follow this symbol to avoid possible injury or death.**

### **▲ WARNING**

**Before installing, using, or servicing this product, carefully read and fully understand the instructions including all warnings, cautions, & safety notice statements. To reduce risk of personal injury, death and/or property damage, follow all instructions for proper motor installation, operation and maintenance.**

**These instructions are not intended as a complete listing of all details for installation, operation, and maintenance. If you have any questions concerning any of the procedures, STOP, and call the appropriate Regal-Beloit motor company.**

### **Table of Contents**

#### **1.0 INSTALLER / OWNER / OPERATOR RESPONSIBILITY**

- 1.1 Electrical Safety
- 1.2 Mechanical Safety
- 1.3 Environmental Safety

#### **2.0 RECEIVING & INSPECTION**

- 2.1 Initial Inspection
  - 2.1.1 Packing List & Inspect
  - 2.1.2 Turn Motor Shaft
  - 2.1.3 Check Nameplate
- 2.2 Handling

- 2.2.1 Correct Lifting Angles
- 2.3 Storage

- 2.3.1 Bearing Lubrication
- 2.3.2 Shaft Rotation
- 2.3.3 Damp or Humid Storage Locations

#### **3.0 INSTALLATION AND OPERATION**

##### **3.1 Location**

- 3.1.1 Selecting a Location
- 3.1.2 Ambient Temperature Limits
- 3.1.3 Construction Selection per Location
  - 3.1.3.1 Dripproof
  - 3.1.3.2 Totally Enclosed
  - 3.1.3.3 Hazardous Locations Motors

##### **3.2 Mounting Motor**

- 3.2.1 Rigid Base (Footed)
- 3.2.2 Rigid Base Hole Selection -6 or 8 Hole Bases
- 3.2.3 Vertical

##### **3.3 Application Assembly to Motor**

- 3.3.1 General: Proper Alignment

##### **3.3.2 Direct Coupling**

##### **3.3.3 Direct Connected**

##### **3.3.4 Belted**

##### **3.3.5 VFD Operation**

##### **3.3.6 Accessories**

###### **3.3.6.1 General**

###### **3.3.6.2 Brake Motors**

###### **3.3.6.3 Space Heaters**

###### **3.3.6.4 Thermal Protection General, Thermostats, Thermistors & RTDs**

###### **3.3.6.5 RTD Alarm & Trip Settings**

##### **3.3.7 Guards**

#### **3.4 Electrical Connections**

##### **3.4.1 Power Supply / Branch Circuit**

###### **3.4.1.1 Branch Circuit Supply**

###### **3.4.1.2 Fuses, Breakers, Overload Relays**

###### **3.4.1.3 AC Power Supply Limits**

##### **3.4.2 Terminal Box**

###### **3.4.2.1 Conduit opening**

###### **3.4.2.2 Hazardous Locations**

##### **3.4.3 Lead Connections**

###### **3.4.3.1 Wire Size Requirements (Single Phase)**

###### **3.4.3.2 Extension Cords (Single Phase)**

##### **3.4.4 Ground Connections**

##### **3.4.5 Start Up**

###### **3.4.5.1 Start Up – No Load Procedure**

###### **3.4.5.2 Start Up – Load Connected Procedure**

###### **3.4.5.3 Jogging and/or repeated starts**

#### **4.0 MAINTENANCE**

##### **4.1 General Inspection**

- 4.1.1 Ventilation
- 4.1.2 Insulation
- 4.1.3 Electrical Connections
- 4.2 Lubrication and Bearings
  - 4.2.1 Grease Type
  - 4.2.2 Bearing Operating Temperature

- 4.2.3 Lubrication Interval
- 4.2.4 Lubrication Procedure
- 4.2.5 Lubrication Example
- 4.3 Trouble Shooting
  - 4.3.1 General Trouble-Shooting Warnings
  - 4.3.2 Trouble-Shooting Cause / Corrective Action

motor is suitable for use on Pulse Width Modulated (PWM) type VFD power. In addition, the nameplate must be marked with the inverter rating; for example, "2:1 CT", "2 to 1 Constant Torque", etc.

## 1.0 INSTALLER/OWNER/OPERATOR RESPONSIBILITY:

### 1.1 ELECTRICAL SAFETY

#### **⚠ WARNING: ELECTRICAL SHOCK HAZARD**

Electrical connections shall be made by a qualified electrical personnel in accordance with all applicable codes, ordinances and sound practices. Failure to follow these instructions could result in serious personal injury, death and/or property damage. Only qualified personnel who are familiar with the applicable National Code (USA = NEC) and local codes should install or repair electrical motors and their accessories.

#### **⚠ WARNING: ELECTRICAL LIVE CIRCUIT HAZARD**

Do not touch electrically live parts. Disconnect, lockout and tag input power supply before installing or servicing motor (includes accessory devices). Use a voltmeter to verify that power is off before contacting conductors.

#### **⚠ WARNING: ELECTRICAL GROUNDING HAZARD**

Failure to properly ground motors, per the National Electrical Code (NEC) Article 430 and local codes may cause serious injury or death to personnel. For general information on grounding refer to NEC Article 250. (Also see "Ground Connections section 3.4.4").

#### **⚠ WARNING: AUTOMATIC RESET PROTECTOR HAZARD**

Do not use automatic reset protectors if automatically restarting the motor will place personnel or equipment at risk. . Failure to follow this instruction could result in serious personal injury, death and/or property damage

#### **⚠ WARNING: MANUAL RESET PROTECTOR HAZARD**

If a tripped manual reset thermal protector is exposed to a temperature less than  $-7^{\circ}\text{C}$  ( $20^{\circ}\text{F}$ ) it may reset and restart the motor automatically. If an application requires a motor with a manual reset thermal protector that will be operated at temperatures less than  $-7^{\circ}\text{C}$  ( $20^{\circ}\text{F}$ ) contact the manufacturer to review the application / motor requirements. Failure to follow this instruction could result in serious personal injury, death and/or property damage

### 1.2 MECHANICAL SAFETY

#### **⚠ WARNING: LOOSE PARTS HAZARD**

Before starting the motor, remove all unused shaft keys and loose rotating parts to prevent them from flying off. Failure to follow these instructions could result in serious personal injury, death and/or property damage.

#### **⚠ WARNING: ROTATING PARTS HAZARD**

Keep extremities, hair, jewelry and clothing away from moving parts. Failure to follow these instructions could result in serious personal injury, death and/or property damage.

### 1.3 ENVIRONMENTAL SAFETY

#### **⚠ WARNING: HAZARDOUS LOCATIONS**

- (1) The NEC and the local authority having jurisdiction must be consulted concerning the installation and suitability of motors for use in Hazardous Locations. The local authority having jurisdiction must make the final determination of what type of motor is required. The application and operation is beyond the control of the motor manufacturer.
- (2) Division 1 Hazardous Locations motors can only be modified or reworked by the manufacturer or a facility that is Listed under UL's category "Motors and Generators, Rebuilt for use in Hazardous Locations". Failure to follow these instructions could result in serious personal injury, death and/or property damage.
- (3) Do not use a Hazardous Locations motor with a Variable Frequency Drive (VFD) unless the motor nameplate specifically states that the

## 2.0 RECEIVING AND INSPECTION

### 2.1 INITIAL INSPECTIONS

**2.1.1 CHECK PACKING LIST AND INSPECT** the packaging to make certain no damage has occurred in shipment. If there is visible damage to the packaging, unpack and inspect the motor immediately. Claims for any damage done in shipment must be made by the purchaser against the transportation company.

**2.1.2 TURN MOTOR SHAFT** by hand to be certain that it rotates freely. Note: Shaft seals and bearing seals may add drag.

**2.1.3 CHECK NAMEPLATE** for conformance with purchase order requirements and compliance with power supply and control equipment requirements.

### 2.2 HANDLING:

#### **⚠ WARNING: FALLING OBJECT HAZARD**

**Eyebolts or lifting lugs, where provided, are intended for lifting only the motor and accessories mounted by the motor manufacturer** (unless specifically stated otherwise on the motor). Utilizing the motor lifting provision to lift other components such as pumps and gear boxes could result in serious personal injury, death and/or property damage.

#### **⚠ WARNING: FALLING OBJECT HAZARD**

Before using the lifting provision, check the eyebolts and/or other lifting means to assure they are not bent or damaged and are completely threaded, seated & secured to the motor. Equipment to lift motor must have adequate lifting capacity. While lifting the motor DO NOT stand under or in the vicinity of the motor. Failure to follow these instructions could result in serious personal injury, death and/or property damage.

#### 2.2.1 LIFTING ANGLE LIMITATIONS

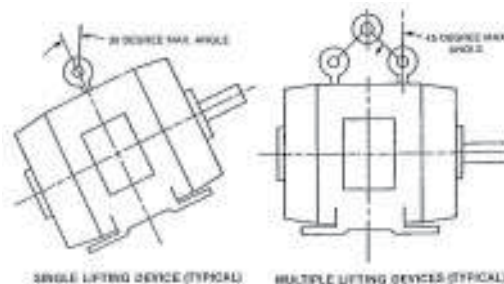

**2.3 STORAGE:** Motors, not put into service immediately, must be stored indoors in a clean, dry location. Avoid locations with large temperature swings that will result in condensation. Motors must be covered to eliminate airborne dust and dirt. If the storage location exhibits high vibration, place isolation pads under motor to minimize damage to motor bearings.

**2.3.1 BEARING LUBRICATION:** Bearings are grease packed at the factory; relubrication upon receipt of motor or while in storage is not necessary. If stored more than one year, add grease per lubrication instructions (Table 4-4) before start-up.

**2.3.2 SHAFT ROTATION:** It is recommended that the motor shaft be rotated 5 to 10 rotations every three months to distribute the grease in the bearings. This will reduce the chance for corrosion to form on the bearing rolling elements and raceways. Note: Shaft seals and bearing seals may add drag.

**2.3.3 DAMP OR HUMID STORAGE LOCATIONS:** Treat unpainted flanges, shafts, and fittings with a rust inhibitor. Apply appropriate power to the motor's space heaters (if so equipped)

**TEFC (Totally Enclosed Fan Cooled)** motors must meet a minimum distance of ½ the shaft height between the fan guard grill openings and the nearest obstruction.

**3.1.3.3 HAZARDOUS LOCATIONS MOTORS:** Hazardous Locations motors are intended for installations in accordance with NEC Article 500. For all installations involving Hazardous Locations motors, consult the applicable national codes, local codes, and the authority having jurisdiction.

**Division 1 Installations – includes Class I & II:** Use only motors that are UL Listed and CSA Certified or UL Listed and UL Certified for Canada. These motors bear a separate nameplate that includes the UL Listing Mark and CSA Certification Mark or includes the UL Listing Mark and the UL Mark for Canada. This plate also bears the phrase: "Electric motor for Hazardous Locations" and is marked with the Class, Group and Operating Temperature Code.

**Division 2 Installations – Class I only:** Use only motors that are CSA Certified and bear the CSA Certification Mark. These motors include a phrase on the main motor nameplate that indicates the motor is CSA Certified for Class I, Division 2 / Zone 2 locations.

**Division 2 Installation – Class II only:** Use only Class II motors as described above under "Division 1 Installations".

**WARNING: EXPLOSION HAZARD**

A motor should never be placed in an area with a hazardous process or where flammable gases or combustible materials may be present unless it is specifically designed and nameplated for this type of service. Hazardous Locations motors are intended for installations in accordance with NEC Article 500. For all installations involving Hazardous Locations motors, consult the NEC, local codes, and the authority having jurisdiction. Failure to follow these instructions could result in serious personal injury, death and/or property damage. (For other limitations see section 1.3)

**3.0 INSTALLATION AND OPERATION**

**WARNING:** Only qualified personnel who are familiar with the appropriate national code, local codes and sound practices should install or repair electrical motors and their accessories. Installation should conform to the appropriate national code as well as local codes and sound practices. Failure to follow these instructions could result in serious personal injury, death and/or property damage.

**WARNING: ELECTRICAL LIVE CIRCUIT HAZARD**

Do not touch electrically live parts. Disconnect, Lockout and Tag input power supply before installing or servicing motor (includes accessory devices). Use a voltmeter to verify that power is off before contacting conductors.

**3.1 LOCATION**

**3.1.1 SELECTING A LOCATION:** Consideration should be given to environment and ventilation. Motors should be installed in an area that is protected from direct sunlight, corrosives, harmful gases or liquids, dust, metallic particles, and vibration. A motor with the proper enclosure for the expected operating condition should be selected. Provide accessible clearance for cleaning, repair, service, and inspections (See section 3.1.3 for construction clearances). The location should be considered for possible future motor removal / handling. The free flow of air around the motor should not be obstructed.

**3.1.2 AMBIENT TEMPERATURE LIMITS:** The ambient temperatures of the air inlet to the motor should not exceed 40°C (104°F) or be less than -30°C (-22°F) unless the motor nameplate specifically states an ambient temperature outside of these limits. The ambient inside an enclosure built around the motor shall not exceed the nameplate ambient. For ambient temperatures outside of these limits consult the motor manufacturer.

**CAUTION: INSULATION DEGRADATION WARNING**  
Insulation at high temperatures ages at an accelerated rate. Each 10°C increase in temperature reduces the insulation life by one half.

**WARNING: HAZARDOUS LOCATIONS AMBIENT LIMIT:** Division 1 Hazardous Locations motors shall **NOT** be operated below -25°C (-13°F) ambient. (Low temperatures reduce the component mechanical properties.)

**3.1.3 CONSTRUCTION SELECTION per LOCATION:**

**3.1.3.1 DRIPPROOF (OPEN) MOTORS** are intended for use indoors where the atmosphere is relatively clean, dry, and non-corrosive. Recommended a minimum clearance of ½ the shaft height between vent openings and the nearest obstruction.

**3.1.3.2 TOTALLY ENCLOSED MOTORS** are suitable for indoor or outdoor standard service applications.

**TEAO or AOM (Totally Enclosed Air Over)** motors must be mounted in the air stream. When the motor nameplate states a minimum airflow the motor must be mounted in an air stream meeting this minimum value.

**3.2 MOUNTING MOTOR:**

**3.2.1 RIGID BASE (FOOTED):** The motor must be securely installed to a rigid foundation or a mounting surface to minimize vibration and maintain alignment between the motor shaft and the load's shaft. The mounting surfaces of the four mounting pads must be flat within 0.01 inches for 210 frame & smaller; 0.015 inches for 250 frame & larger. [IEC 0.25 mm for 130 frame & smaller, 0.38 mm for 160 frame & larger]. This may be accomplished by shims under the motor feet. For special isolation mounting, contact manufacturer for assistance

**3.2.2 RIGID BASE HOLE SELECTION -6 OR 8 HOLES**

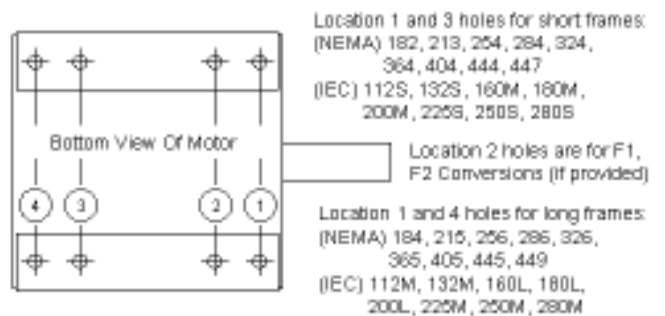

**3.2.3 VERTICAL MOUNTING:**

**CAUTION: ENCLOSURE PROTECTION CAUTION:** Most Drip-proof rigid base (footed) motors do **NOT** meet "Drip-proof" requirements when mounted vertically. If the motor is located in unprotected environments, the addition of a drip cover may be available. Drip covers not available for cast iron rigid base motors.

**WARNING: FALLING OBJECT HAZARD**

The lifting provision on standard horizontal footed motors is not designed for lifting the motor in a vertical shaft up or shaft down position. (see 2.2.1 lifting angles). Lifting method / provisions for

mounting a rigid base (footed) motor vertically is the responsibility of the installer.

**VERTICAL SHAFT DOWN:** Most standard horizontal motors thru 449 Fr. (excluding brake motors) can be mounted in a vertical shaft down orientation. For vertical brake motors see section 3.3.6.2.

**VERTICAL SHAFT UP:**

**⚠ WARNING: HAZARDOUS LOCATIONS VERTICAL MOUNT:** Hazardous locations motors must **NOT** be mounted vertically shaft up without approval by the motor manufacturer. Without proper retaining provisions the rotor may move axially and contact components, creating a spark hazard.

**Belted or Radial Load when mounted vertically:** The following frame sizes / constructions with applied (axial) down loads within the limit stated are acceptable when mounted vertical shaft up.

**Table 3-1 Belted or Radial Load Applications (All speeds)**

Frame Size	Enclosure	Construction	Shaft Up OK	Max Applied Down Load <sup>3</sup>
56	TEFC & ODP	Steel	Yes	25 lbs
140	TEFC	Steel & Cast Iron	Yes	25 lbs
	ODP	Steel	Yes	25 lbs
180	TEFC	All	Yes	35 lbs
	ODP	Steel	Yes	35 lbs
210	TEFC	All	Yes	40 lbs
	ODP	Steel	Yes	40 lbs
250	TEFC	All	Yes	40 lbs
	ODP	Steel	Yes	40 lbs
		Cast Iron	No <sup>2</sup>	N/A
280-320	320 TTFC models	Cast Iron	Eng <sup>1</sup>	N/A
	All Other TEFC	Cast Iron & Aluminum	Yes	30 lbs
	ODP	Cast Iron	No <sup>2</sup>	N/A
	TEFC & ODP	Steel	Build Up Only <sup>4</sup>	N/A
360 & Up	TEFC	Cast Iron	Build Up Only <sup>4</sup>	N/A
	ODP	Cast Iron	No <sup>2</sup>	N/A
	TEFC & ODP	Steel	Build Up Only <sup>4</sup>	N/A

Notes:

- For TEFC model numbers beginning with 324TTFC or 326TTFC consult the motor manufacturer to determine if a build up motor is required.
- The max applied down load is any applied load external to the motor, including such things as sheave weight, fan loads, axial belt force, pump load, etc. If the application is direct drive with no applied radial load, consult the motor manufacturer.
- "Build-up only", refers to motors that are specifically ordered and built for shaft up applications. It does not imply that all build-up motors are suitable for shaft up applications.

**3.3 APPLICATION ASSEMBLY TO MOTOR:**

**⚠ CAUTION: EQUIPMENT DAMAGE:**

Do not connect or couple motor to load until correct rotational direction is established.

**3.3.1 GENERAL: PROPER ALIGNMENT** of the motor and driven equipment minimizes vibration levels, maximizes bearing life, and extends the overall life of the machinery. Consult the drive or equipment manufacturer for more information.

**⚠ CAUTION: BEARING FAILURE**

During assembly do NOT force components onto the shaft. Striking or hammering the component may result in bearing damage.

**3.3.2 DIRECT COUPLING:** Use flexible couplings if possible. For applications that apply radial, axial or moment loading on the motor shaft see section 3.3.3.

**⚠ CAUTION: BEARING FAILURE**

Unless approved by the motor manufacturer do **NOT** direct couple a vertical shaft up or roller bearing motor. Direct coupling a vertical shaft up motor or a motor with a roller bearing may result in bearing damage.

**3.3.3 DIRECT CONNECTED:** Radial loading for direct connected equipment (gears, fans etc.) must be approved by the motor manufacturer unless within the maximum overhung load limits (Table 3-2). Combined loading (axial, radial and/or moments) must be approved by motor manufacturer. For belted loads see section 3.3.4.

**Table 3-2 Maximum Radial Load (lbf) @ Middle of the Shaft Extension Length**

Frame Number	Motor Rated RPM			
	3600	1800	1200	900
143T	106	166	193	210
145T	109	170	199	218
182T	187	230	261	287
184T	193	237	273	301
213T	319	317	470	510
215T	327	320	480	533
254T	500	631	729	793
256T	510	631	736	820
284T	-	866	990	1100
286T	-	871	1005	1107
324T	-	950	1100	1215
326T	-	950	1113	1230
364T	-	1078	1365	1515
365T	-	1078	1380	1540
404T	-	1388	1590	1762
405T	-	1400	1610	1780
444T	-	1580	1795	2005
445T	-	1520	1795	1985
447T	-	1455	1765	1985
449T	-	1640	1885	2130

Values based on 26,280 hrs B-10 Life  
 For "End of Shaft" Load multiply value by 0.88  
 To convert from lbf to N multiply value by 4.4482.

**3.3.4 BELTED:**

The goal of any belted system is to efficiently transmit the required torque while minimizing the loads on the bearings and shafts of the motor and driven equipment. This can be accomplished by following four basic guidelines:

- Use the largest practical sheave diameter.
- Use the fewest number of belts possible.
- Keep sheaves as close as possible to support bearings.
- Tension the belts to the lowest tension that will still transmit the required torque without slipping. It is normal for V-belts to squeal initially when line starting a motor

**3.3.4.1 Sheave Diameter Guidelines:**

In general, smaller sheaves produce greater shaft stress and shaft deflection due to increased belt tension. See Table 3-3 for recommended minimum sheave diameters. Using larger sheaves increases the contact with belts which reduces the number of belts required. It also increases the belt speed, resulting in higher system efficiencies. When selecting sheaves, do not exceed the manufacturer's recommended maximum belt speed, typically 6,500 feet per minute for cast iron sheaves. Determine belt speed by the following formula:

Figure 1



$$\text{BELT SPEED (Ft/min)} = \frac{\text{Shaft RPM} \times 3.14 \times \text{Sheave Dia (inches)}}{12}$$

### 3.3.4.2 Number of Belts

In general, use the fewest number of belts that will transmit the required torque without slipping. See Table 3-3 for recommended maximum number of belts. Each belt adds to the tension in the system, which increases load on the shafts and bearings. Belts are most efficient when operated at or near their rated horsepower. If the sheaves have more grooves than the number of belts required, use the grooves closest to the motor.

### 3.3.4.3 Sheave Location

Install sheaves as close to the housing as possible to increase the bearing life of the motor and driven equipment.

Figure 2

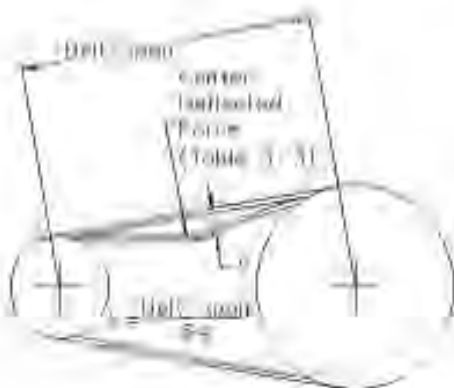

### 3.3.4.4 Belt Tension

#### ⚠ CAUTION: Equipment Failure Caution

Belt tensioning by feel is NOT acceptable. Tensioning by "feel" can be very misleading, and can damage motor and equipment. It is normal for V-belts to squeal initially when line starting a motor.

In general, belt tensions should be kept as loose as possible while still transmitting the required torque without slipping. Belt tensions must be measured with a belt tension gage. These inexpensive gages may be obtained through belt manufacturers, or distributors.

Proper belt tension is determined by measuring the force required to deflect the center of the belt a given distance. The proper deflection (in inches) is determined by dividing the belt span in inches by 64. Calculate the proper deflection and then see Table 3-3 for the required "Deflected Force" to achieve that deflection.

After tensioning the belt, rotate the sheaves for several rotations or operate the system for a few minutes to seat belts into the grooves, then re-tension the belts. New belts will stretch during use, and should be retensioned after the first eight hours of use.

**Table 3-3 Recommended Minimum Sheave Diameters, Belt Type, Number of Belts and Deflected Force**

Motor Hp	1200 rpm				1800 rpm				3600 rpm			
	Min Sheave Dia (in)	Belt Type	Max # of Belts	Avg. Deflected Force (lbs)	Min Sheave Dia (in)	Belt Type	Max # of Belts	Avg. Deflected Force (lbs)	Min Sheave Dia (in)	Belt Type	Max # of Belts	Avg. Deflected Force (lbs)
0.75	2.2	3VX	1	2.4	2.2	3VX	1	2.2	2.2	3VX	1	1.2
1	2.4	3VX	1	4.0	2.2	3VX	1	3.1	2.2	3VX	1	1.6
1.5	2.4	3VX	2	3.1	2.4	3VX	2	2.1	2.2	3VX	1	2.5
2	2.4	3VX	3	2.8	2.4	3VX	2	2.9	2.4	3VX	1	2.7
3	3.0	3VX	2	3.3	2.4	3VX	3	2.9	2.4	3VX	2	2.3
5	3.0	3VX	3	4.0	3.0	3VX	3	3.7	2.4	3VX	3	2.5
7.5	3.8	3VX	4	4.7	3.0	3VX	4	4.1	3.0	3VX	2	4.2
10	4.4	3VX	4	5.4	3.8	3VX	4	4.3	3.0	3VX	3	3.8
15	4.4	3VX	5	5.4	4.4	3VX	4	5.4	3.8	3VX	3	4.4
20	5.2	3VX	6	6.0	4.4	3VX	6	4.8	4.4	3VX	3	5.0
25	6.0	3VX	7	5.6	4.4	3VX	7	5.2	4.4	3VX	4	4.7
30	6.8	3VX	7	5.9	5.2	3VX	7	5.3				
40	6.8	5VX	4	11.6	6.0	3VX	7	6.0				
50	8.2	5VX	4	14.6	6.8	3VX	8	5.9				
60	8.2	5VX	5	14.1	7.4	5VX	4	13.3				
75	10.0	5VX	5	14.5	8.6	5VX	4	14.3				
100	10.0	5VX	6	16.0	8.6	5VX	6	13				
125	12.0	5V	7	14.1	10.5	5V	6	13.1				
150	13.2	5V	7	15.4	10.5	5V	7	13.4				
200	15.0	5V	8	16.0	13.2	5V	8	13.1				
250	15.0	8V	6	27.6	14.0	5V	9	13.8				
300	16.0	8V	7	27.1	14.0	5V/8V	11 / 7	23.4				
350	16.5	8V	7	30.3	14.5	5V/8V	12 / 7	26.0				
400	17.5	8V	8	29.1	15.0	5V/8V	13 / 8	25.7				
450	18	8V	8	31.6	16.0	5V/8V	14 / 9	25.2				
500	18.5	8V	9	30.7	16.5	5V/8V	15 / 9	26.9				
600					17.5	8V	11	26.3				
700					19.0	8V	12	27.3				
800					20.0	8V	13	28.2				

**Contact Motor Manufacturer when Belting 3600 rpm Motors Greater than 25 HP**

**Notes:**

1. Horsepower is the nameplate motor horsepower, and RPM is the motor (driver) speed.
2. Minimum sheave diameters are from NEMA standards where applicable.
3. **For variable speed applications or values outside these recommendations, consult motor manufacturer.**
4. Selections are based on a 1.4 service factor, 5 to 1 speed ratio and various Power Transmission Manufacturers' catalogs.
5. These selections are for Narrow V-belt sections only. Consult manufacturer for details on conventional V-belt sections (A, B, C, D and E), or other belt types.
6. "Average Deflected Force is per section 3.3.4.4 of this document and is the force required to deflect the center of a belt 1/64 of the belt span distance. Tolerance on this force is ±1 lbf for forces ≤10 lbs, and ±2 lbs for forces >10 lbs as measured utilizing a belt tension gage.
7. When more than one belt is required the belts must be a matched set (matched for length).
8. If possible, the lower side of the belt should be the driving side to increase the length of wrap on the sheave).
9. For belted loads do not exceed 125% of 60 Hz operating RPM.

**3.3.5 VFD (Variable Frequency Drives) OPERATION:**

**⚠ WARNING: VFD Motors with Reset Thermal Protectors**  
UL Recognition, UL Listing, or CSA certification does not apply to motors that are equipped with a manual or automatic reset thermal protector when the motor is operated on VFD power.

**⚠ WARNING: Power Factor Correction Capacitors:**  
Power factor correction capacitors should never be installed between the drive and the motor.

**⚠ CAUTION: VFD / Motor Setup:**  
It is the responsibility of the startup personnel during set up of the VFD / motor system to properly tune the drive to the motor for the specific application per the VFD user manual. The correct voltage boost and volts per hertz settings are application dependent and unique to each motor design. Failure to connect over temperature devices (when provided) will void the warranty.

**3.3.5.1 Overspeed Capability:**

Belted loads: Do not exceed 125% of 60 Hz operating RPM.

**Table 3-4 Maximum Safe Continuous Speed (RPM) For Coupled and Direct Connected Loads**

NEMA / [IEC] Frame Size	2-Pole	4, 6, or 8 Pole
56-180 [80-110]	7200 *	5400 *
210-250 [130-160]	5400 *	4200*
280 [180]	5400 *	3600
320 [200]	4500 *	3600
360 [225]	4500 *	2700
400-440 [250-280]	3600	2700
>440 [>280]	3600	1800

\* = Fan cooled motors (Totally Enclosed & Hazardous Locations Motors) are limited to a maximum safe continuous speed of 4000 RPM **For higher speeds or shortened duty cycle contact motor manufacturer**

**3.3.5.2 Cable Lengths:** For optimum insulation life, limit VFD to motor cable lengths of general purpose motors

to Table 3-5 values. Definite purpose VFD motors may accommodate longer cable lengths. For additional information contact motor manufacturer.

**Table 3-5 Max Cable Lengths General Purpose Motors**  
These values are based on 3 kHz carrier frequency. Add suitable VFD output-side filters when exceeding the listed values.

Frame Size	230V	460 V	575 V
NEMA 56-320	600 ft.	125 ft.	40 ft.
NEMA 360-5011	1000 ft.	225 ft.	60 ft.
IEC 80-200	180 m.	40 m.	12 m.
IEC 225-280.	300 m.	70 m.	18 m.

**3.3.5.3 VFD Grounding:** Equipment grounding conductors may be run in the same conduit as the AC motor power leads. This wire must be used as the equipment ground for the motor and not as the fourth current carrying wire of a "WYE" motor circuit. The grounded metal conduit carrying the output power conductors can provide EMI shielding, but the conduit does not provide an adequate ground for the motor; a separate grounding conductor must be used. Grounding the motor neutral (WYE) of a VFD powered motor may result in a VFD ground fault trip. Improper grounding of an inverter fed motor may result in frame voltages in excess of 500 Volts. Refer to Grounding section 3.4.4

**3.3.5.4 VFD – Single Phase:**

**CAUTION: SINGLE PHASE MOTOR FAILURE:**

Single Phase motors are **NOT** suitable for use on VFD power. Connecting a Single Phase Motor to a VFD voids the warranty.

**3.3.5.5 Stray Voltage on Accessory Leads:**

VFD's will couple stray (common-mode) voltage to motor-mounted RTDs, thermistors, thermostats and space heaters. The leads of these elements must be properly insulated and control input circuits must be designed to withstand this common-mode voltage.

**3.3.6 ACCESSORIES / PROVISIONS:**

**3.3.6.1 General:** Carefully read and understand the accessory manufacturer's instructions, supplied with motor. Contact the manufacturer for additional information.

**3.3.6.2 Brake Motors:**

**CAUTION: Vertical Motor Premature Brake Failure**  
Motors with brakes that are designed for vertical applications are equipped with springs to support the brake pressure plate. Mounting a horizontal brake motor vertically shaft up or down may require a pressure plate spring modification. Failure to modify the brake for the vertical application may result in premature brake failure. If in question, consult brake literature or brake manufacturer.

**Brake Solenoid Wiring:** Do NOT connect the brake solenoid to the output of a VFD. The brake solenoids must be wired to 50/60 Hz line power

**3.3.6.3 Space Heaters:**

Motors provided with space heaters have two leads that are brought into the conduit box or into an auxiliary box. These leads are marked "H1", "H2" ("H3", "H4" if a second space heater is supplied). See the space heater nameplate on motor for heater rating.

**WARNING: DIVISION 2 EXPLOSION HAZARD**

The space heater temperature rating when used in Class I, Division 2 motors shall **NOT** exceed 80% of the auto ignition temperature of the hazardous gas or vapor. See the space heater nameplate on motor for heater Temperature Code and heater rating. Failure to follow this instruction could result in serious personal injury, death and/or property damage

**3.3.6.4 Thermal Protection:**

**General Information:** When thermal protection is provided, one of the following will be stamped on the nameplate:

1. **"THERMALLY PROTECTED"** This motor has built in thermal protection. Thermal protectors open the motor circuit electrically when the motor overheats or is overloaded. The protector cannot be reset until the motor cools. If the protector is automatic, it will reset itself. If the protector is manual, disconnect motor from power supply. After protector cools (five minutes or more) press the reset button and reapply power to the motor. In some cases a motor is marked "Auto" and the connection diagram on the motor will identify T'Stat leads – see "2" below. (See warnings on Manual and Automatic reset protectors - section 1.1)

2. **"WITH OVERHEAT PROTECTIVE DEVICE"**: This motor is provided with an overheat protective device that does not directly open the motor circuit. Motors nameplated with this phrase have either thermostats, thermistors or RTD's. The leads to these devices are routed into the motor conduit box or into an auxiliary box. The lead markings are defined on the nameplate (normally "P1", "P2"). The circuit controlled by the overheat protection device must be limited to a maximum of 600 volts and 360 volt-amps. See connection decal provided inside the terminal box cover. Failure to connect these over temperature devices (when provided) will void the warranty.

**WARNING: EXPLOSION HAZARD**

For Hazardous Locations motors provided with thermostats UL and the NEC require connection of thermostat leads into the control portion of a manual reset start circuit. Failure to follow this instruction could result in serious personal injury, death and/or property damage

**Resistance Temperature Detectors (RTD):** When winding and/or bearing RTDs are provided the RTD lead markings are defined on the nameplate. (Normally "R1", "R2", "R3" etc.)

**3.3.6.5 RTD Alarm & Trip Settings:**

Tables 3-6 & 3-7 are suggested initial RTD alarm and trip settings. For motors found to operate significantly below these values the settings may be reduced accordingly.

**Table 3-6 Winding RTD – Temperature Limit (°C)  
40 °C Max Ambient**

Motor Load	Class B Temp Rise ≤ 80°C		Class F Temp Rise ≤ 105°C	
	Alarm	Trip	Alarm	Trip
Up to 1.0 SF	130	140	155	165
>1.0 to 1.15 SF	140	150	160	165

**Table 3-7 Bearing RTD – Temperature Limit (°C)  
40 °C Max Ambient**

Ambient	Alarm	Trip
Up to 40°C	95	100
> 40°C	110	115
Bearings that are Heat Stabilized to 150 °C	130	135

**3.3.7 GUARDS:**

**WARNING: ROTATING PARTS HAZARD**

When devices are assembled to the motor shaft, be sure to install protective devices such as belt guards, chain guards, and shaft covers. These devices must protect against accidental contact with extremities, hair, and clothing. Consider the application and provide guarding to protect personnel. Remove all unused shaft keys and loose rotating parts to prevent them from flying off and causing bodily injury. Failure to follow this warning could result in serious personal injury, death and/or property damage.

### 3.4 ELECTRICAL CONNECTIONS:

#### ⚠ WARNING: ELECTRICAL HAZARDS

Before proceeding read Section 1-1 on Electrical Safety. Failure to follow the instructions in Section 1-1 could result in serious personal injury, death and/or property damage

#### 3.4.1 POWER SUPPLY / BRANCH CIRCUIT

##### ⚠ WARNING: POWER SUPPLY INCOMPATIBILITY HAZARD

Check power supply to make certain that voltage, frequency and current carrying capacity are in accordance with the motor nameplate. Failure to match motor nameplate values could result in serious personal injury, death and/or property damage

##### ⚠ WARNING: BRANCH CIRCUIT SUPPLY HAZARD

Motor and control wiring, fusing, overload protection, disconnects, accessories and grounding must always conform to the applicable electrical codes as well as local codes and sound practices.

**3.4.1.1 Branch Circuit Supply** to a motor should include a disconnect switch, short circuit current fuse or breaker protection, motor starter (controller) and correctly sized thermal elements or overload relay protection.

#### 3.4.1.2 Fuses, Breakers, Overload Relays

Short Circuit Current Fuses or Breakers are for the protection of the branch circuit. Starter or motor controller overload relays are for the protection of the motor. Each of these should be properly sized and installed per the applicable electrical codes as well as local codes and practices.

##### ⚠ WARNING: PROTECTIVE DEVICE DISABLED HAZARD

DO NOT bypass or disable protective devices. Protection removal could result in serious personal injury, death and/or property damage

#### 3.4.1.3 AC Power Supply Limits

Motors are designed to operate within the following limits at the motor terminals:

- 1- AC power is within +/- 10 % of rated voltage with rated frequency applied. (Verify with nameplate ratings) **OR**
- 2- AC power is within +/- 5% of rated frequency with rated voltage **OR**
- 3- A combined variation in voltage and frequency of +/- 10% (sum of absolute values) of rated values, provided the frequency variation does not exceed +/-5% of rated frequency.
- 4- For 3 phase motors the line to line full load voltage must be balanced within 1%.
- 5- If the motor is rated 208-230V, the voltage deviations must be calculated from 230V.

#### CAUTION: Reduced Motor Performance

Operation outside of these limits will degrade motor performance and increase operating temperature.

### 3.4.2 TERMINAL BOX:

**3.4.2.1 Conduit Opening:** For ease of connections, motors are typically provided with large terminal boxes. Most motors have conduit access in 90 degree increments, the terminal box conduit opening is typically provided via knockouts, holes with covers, or the terminal box is rotate-able. Fabricated conduit boxes may have a removable plate for the installer to provide correctly sized hole(s).

#### 3.4.2.2 Hazardous Locations Motors:

##### ⚠ WARNING: EXPLOSION HAZARDS

(1) **Terminal Boxes mounted to motor with a pipe nipple:** If a pipe nipple mounted terminal box is removed or rotated it must be reassembled with a minimum of five full threads of engagement.

(2) **Component Removal:** Do not set a terminal box component on its machined surfaces. Prior to component reassembly wipe clean all machined surfaces.

(3) **Machined Surface Gap (Hazardous Locations Terminal Boxes):** The gap between mating surfaces with the machined terminal box **MUST BE LESS THAN 0.002 inches.** This gap must be checked with a feeler gage along the entire perimeter. If there is visible damage to the mating surfaces, or if the gap between these surfaces exceeds 0.002 inches, **DO NOT** complete the installation and contact the motor manufacturer. Failure to follow these instructions could result in serious personal injury, death and/or property damage

### 3.4.3 LEAD CONNECTIONS

Electrical connections to be made per nameplate connection diagram or separate connection plate. In making connections follow the applicable electrical code as well as local codes and practices.

##### ⚠ WARNING: ELECTRICAL CONNECTION HAZARD

Failure to correctly connect the motor leads and grounding conductor can result in injury or death. Motor lead connections can short and cause damage or injury if not well secured and insulated.

#### 3.4.3.1 Wire Size (Single Phase) Requirements

The minimum wire size for Single Phase, 115 & 230 Volt Circuits must meet table 3-8 for a given distance between motor and either Fuse or Meter Box.

**Table 3-8 Minimum Wire Gage Size Single Phase 115 & 230 Volt Circuits**

Motor HP	Distance (Feet) - Motor to Fuse or Meter Box							
	100 Ft.		200 Ft.		300 Ft.		500 Ft.	
	115	230	115	230	115	230	115	230
1/4	14	14	10	12	8	10	6	8
1/3	12	14	10	12	6	10	4	8
1/2	10	12	8	10	6	8	4	6
3/4	10	12	6	10	4	8	2	6
1	8	10	6	8	4	6		4
1 1/2	4	10	0	8		6		4
2		8		6		4		2
3		8		6		4		2
5		6		4		2		0

#### 3.4.3.2 Extension Cords (Single Phase Motors):

Where an extension cord(s) is utilized to provide power to the motor the extension cord(s) must be...(1) the proper gauge size per table 3-8, (2) in good working condition (3) properly grounded.

### 3.4.4 GROUND CONNECTION(S):

##### ⚠ WARNING: ELECTRICAL GROUNDING HAZARD

For general information on grounding (USA) refer to NEC Article 250. Improper grounding of an inverter fed motor may result in frame voltages in excess of 500 Volts. In making the ground connection, the installer must make certain that a good electrical connection is obtained between motor and grounding lead. Failure to properly ground motors, per the applicable national code (such as NEC Article 430) and local codes may cause serious injury or death to personnel.

**Primary "Internal" Ground:** A grounding conductor must be connected to the grounding terminal provided in the terminal housing. This grounding terminal is either a ground screw, ground lug, or a tapped hole to be used with a separately provided ground screw. The internal grounding feature is accessible inside the terminal housing and must be used as the primary grounding connection.

**Secondary "External" Ground:** Some motors are provided with a supplemental grounding terminal located on the external surface of the motor frame or feet. This external terminal is for supplemental bonding connections where local codes permit or require such connection

### 3.4.5 START UP:

##### ⚠ WARNING: ELECTRICAL SHOCK HAZARD:

Be certain that all connections are secure and the conduit box cover is fastened in place before electrical power is connected. Failure to follow these instructions could result in serious personal injury, death, and/or property damage.

Do not start more than twice in succession under full load. Repeated starts and/or jogs of induction motors can cause overheating and immediate failure. Contact the motor manufacturer if it is necessary to repeatedly start or jog the motor.

**⚠ WARNING: LOOSE & ROTATING PARTS HAZARD**

Before proceeding read Section 1-2 on Mechanical Safety. Failure to follow the instructions in Section 1-2 could result in serious personal injury, death and/or property damage

**⚠ WARNING: EXCESSIVE SURFACE TEMPERATURE HAZARD**

Motors with the temperature code stated on the nameplate are designed to operate within this limit. Improper application or operation can cause the maximum surface temperature to be exceeded. A motor operated in a Hazardous Location that exceeds this surface temperature limit increases the potential of igniting hazardous materials. *Therefore, motor selection, installation, operation, and maintenance must be carefully considered to ensure against the following conditions:* (1) Motor load exceeds service factor value, (2) Ambient temperature above nameplate value, (3) Voltages outside of limits (3.4.1.3), (4) Loss of proper ventilation, (5) VFD operation exceeding motor nameplate rating, (6) Altitude above 3300 feet / 1000 meters, (7) Severe duty cycles, (8) Repeated starts, (9) Motor stall, (10) Motor reversing, and (10) Single phase operation. Failure to follow these instructions could result in serious personal injury, death and/or property damage.

**⚠ CAUTION: HOT SURFACE**

Normal motor surface temperatures may exceed 90 ° C (194° F). Touching the motor frame may cause discomfort or injury. Surface temperatures should only be measured with suitable instruments and not estimated by hand touch.

**3.4.5.1 Start Up - No Load Procedure**

- 1. Check Instructions:** Before startup carefully read and fully understand these instructions including all warnings, cautions, and safety notice statements.
- 2. Motor out of storage after more than three months:** Check winding insulation integrity with a Megger. If winding resistance to ground is less than 1.5 Meg-ohms consult the local authorized service shop before energizing the motor.
- 3. Check Installation: Mechanical -** Check tightness of all bolts and nuts. Manually rotate the motor shaft to ensure motor shaft rotates freely. Note: Shaft & bearing seals will add drag.  
**Electrical -** Inspect all electrical connections for proper terminations, clearance, mechanical tightness and electrical continuity. Be sure to verify connections are made per the nameplate connection diagram or separate connection plate. Replace all panels and covers that were removed during installation before energizing the motor.
- 4. Energize Motor: Check Rotation**  
If practical check motor rotation before coupling to the load. Unlock the electrical system. Momentarily provide power to motor to verify direction of rotation. If opposite rotation is required, lock out power before reconnecting motor. If motor has a rotational arrow only operate the motor in the rotation identified. Reapply power to ensure proper operation.
- 5. Record No Load Amps, Watts & Voltage:**  
Recommend - To establish a baseline value check and record the no load amps, watts, and voltage.

**3.4.5.2 Start Up – Load Connected Procedure**

- 1. Check Instructions:** Before startup carefully read and fully understand these instructions including all warnings, cautions, & safety notice statements.
- 2. Coupling Installation:** Check that the connected equipment is properly aligned and not binding. Check that all guards and protective devices are properly installed.
- 3. Energize Motor:** When all personnel are clear of the machine, apply power and verify that the load is not transmitting excessive vibration back to the motor through the shaft or the foundation. Verify that motor amps are within nameplate rating. For repeated starts see 3.4.5.3. The equipment can now be fully loaded and operated within specified limits as stated on the nameplate.

**3.4.5.3 Jogging and/or Repeated Starts**

**4.0 MAINTENANCE:**

**⚠ WARNING: Hazardous Locations Motor Repair HAZARD:** Division 1 Hazardous Locations motors can only be modified or repaired by the manufacturer or a facility that is Listed under UL's category "Motors and Generators, Rebuilt for use in Hazardous Locations". Failure to follow these instructions could result in serious personal injury, death and/or property damage.

**⚠ WARNING: ELECTRICAL SHOCK HAZARD** Electrical connections are to be made by qualified electrical personnel in accordance with all applicable codes, ordinances and sound practices. Failure to follow these instructions could result in serious personal injury, death and/or property damage. Only qualified personnel who are familiar with the applicable national codes, local codes and sound practices should install or repair electric motors and their accessories.

**⚠ WARNING: ELECTRICAL LIVE CIRCUIT HAZARD** Do not touch electrically live parts. Disconnect, lockout and tag input power supply before installing or servicing motor (includes accessory devices).

**4.1 GENERAL INSPECTION**

Inspect the motor approximately every 500 hours of operation or every three months, whichever occurs first. Keep the motor clean and the ventilation and fin openings clear. The following steps should be performed at each inspection:

**4.1.1 VENTILATION:** Check that the ventilation openings and/or exterior of the motor is free of dirt, oil, grease, water, etc, which can accumulate and block motor ventilation. If the motor is not properly ventilated, overheating can occur and cause early motor failure.

**4.1.2 INSULATION:** Use a "Megger" periodically to ensure that the integrity of the winding insulation has been maintained. Record the Megger readings. If winding resistance to ground is less than 1.5 Meg-ohms consult the local authorized service shop before re-energizing the motor.

**4.1.3 ELECTRICAL CONNECTIONS:** Check all electrical connectors to be sure that they are tight.

**4.2 LUBRICATION & BEARINGS:**

The lubricating ability of grease (over time) depends primarily on the type of grease, the size of the bearing, the speed at which the bearing operates and the severity of the operating conditions. Longer bearing life can be obtained if the listed recommendations are followed:

NOTE: If lubrication instructions are provided on the motor nameplate, the nameplate instructions will supersede these instructions. Motors marked "Permanently Lubricated" do not require additional service.

**⚠ CAUTION: BEARING / MOTOR DAMAGE WARNING**

Lubricant should be added at a steady moderate pressure. If added under heavy pressure bearing shield(s) may collapse. Over greasing bearings greatly increases bearing friction and can cause premature bearing and/or motor failure.

**4.2.1 GREASE TYPE (unless nameplate states otherwise):**  
**Nameplate Ambient Temperature between -30°C (-22°F) to 65°C (150°F) inclusive:** Recommended grease for standard service conditions is Mobil Polyrex® EM. Equivalent and compatible greases include: Texaco Polystar RB, Rykon Premium #2, Pennzoil Pen 2 Lube, Chevron SRI & Mobil SHC 100.

**Nameplate Ambient Temperature below -30°C (-22°F):** Special low temperature grease is recommended, such as Aershell 7 or Beacon 325 for ball bearings and Mobil SHC 100 for roller bearings.

Nameplate Ambient Temperature above 65°C (150°F): Dow Corning DC44 or equivalent, a special high temperature grease is required. Note that Dow Corning DC44 grease does not mix with other grease types.

For RTD settings see Table 3-7.

**4.2.2 BEARING OPERATING TEMPERATURE:**

**⚠ CAUTION: HOT SURFACE**

The external surface temperature of the end shield (bracket) bearing hub may reach 100° C (212° F) during normal operation. Touching this surface may cause discomfort or injury. Surface temperatures should only be measured with suitable instruments and not estimated by hand touch.

**4.2.3 LUBRICATION INTERVALS: (For motors with regreasing provisions)**

Eq. 4.2 Lubrication Interval = [(Table 4-1) hrs] x [Interval Multiplier (Table 4-2)] x [Construction Multiplier (Table 4-3)]

**Table 4-1 Lubrication Intervals (Hours) These values are based on average use.**

NEMA / [IEC] Frame Size	Operating Speed – RPM (See Table 3.4 for Maximum Operating Speed)					
	<7200	<5400	<4500	<3600	<1800	<1200
56-180 [80-110]	2500 Hrs.	4000 Hrs	5000 Hrs	6000 Hrs.	17000 Hrs.	20000 Hrs.
210-250 [130-160]		2500 Hrs	4000 Hrs	5000 Hrs.	12000 Hrs.	16000 Hrs.
280 [180]		2000 Hrs	3000 Hrs	4000 Hrs.	10000 Hrs.	14000 Hrs.
320 [200]			2000 Hrs	3000 Hrs.	9000 Hrs.	12000 Hrs.
360 [225]			1500 Hrs	2000 Hrs.	8000 Hrs.	10000 Hrs.
400-440 [250 – 280]				1500 Hrs.	4000 Hrs.	7000 Hrs.
>440 [>280]				1000 Hrs.	3000 Hrs.	5000 Hrs.

**Seasonal Service:** If motor remains idle for more than six months, Lubricate at the beginning of the season, then follow lubrication interval. **Do not exceed maximum safe operating speed Table 3-4 without manufacturer's approval**

**Table 4-2 Service Conditions**

Use highest level Multiplier: Maximum Ambient Temperature and Contamination are independent factors

Severity of Service	Maximum Ambient Temperature	Atmospheric Contamination	Multiplier
Standard	Less than 40° C (104° F)	Clean, Slight Corrosion, indoors, less than 16 hrs per day	1.0
Severe	Above 40° C (104° F) to 50° C	Moderate dirt or Corrosion or outdoors or more than 16 hrs per day	0.5
Extreme	Greater than 50° C or Class H Insulation	Severe dirt or Abrasive dust or Corrosion	0.2

**Table 4-3 Construction Multiplier**

Construction	Multiplier
Angular Contact or Roller Bearing	0.5
Vertical Motor	0.5
All others	1.0

**Table 4-4 Relubrication Amounts**

Frame Size		Volume		
NEMA	IEC	Cu. In.	Fluid oz	ml
48-56	80	0.25	0.14	4.0
143-145	90	0.25	0.14	4.0
182-184	110	0.50	0.28	8.0
213-215	130	0.75	0.42	12.5
254-256	160	1.00	0.55	16.0
284-286	180	1.50	0.83	25.0
324-326	200	2.00	1.11	33.0
364-365	225	3.00	1.66	50.0
404-405	250	3.80	2.11	62.0
444-449	280	4.10	2.27	67.0
>449	>280	4.50	2.50	74.0

For regreasing while operating multiply volume by 125%.

#### 4.2.4 LUBRICATION PROCEDURE: (For Motors with Regreasing Provisions)

##### CAUTION: BEARING DAMAGE WARNING

Added grease must be compatible with the original equipment's grease. If a grease other than those stated in 4.2.1 is to be utilized contact the motor manufacturer. Nameplate information supersedes section 4.2.1 (GREASE TYPE). New grease must be free of dirt. Failure to follow these instructions and procedure below may result in bearing and/or motor damage.

For an extremely dirty environment, contact the motor manufacturer for additional information.

##### LUBRICATION PROCEDURE:

1. Clean the grease inlet plug or zerk fittings prior to regreasing.
2. (If present) Remove grease drain plug and clear outlet hole blockage.

##### CAUTION: GREASE DRAIN PLUGGED:

Old grease may completely block the drain opening and must be mechanically removed prior to regreasing. Forcing a blocked drain open by increased greasing pressure may collapse bearing shields and / or force excess grease through the bearings and into the motor.

3. Add grease per Table 4-4
4. Re-install grease inlet and drain plugs (if removed).

##### WARNING: EXPLOSION HAZARD

Do NOT energize a Hazardous Locations motor without all grease fittings properly installed.

#### 4.2.5 EXAMPLE: LUBRICATION

Assume - NEMA 286T (IEC 180), 1750 RPM Vertical motor driving an exhaust fan in an ambient temperature of 43° C and the atmosphere is moderately corrosive.

1. Table 4-1 list 10,000 hours for standard conditions.
2. Table 4-2 classifies severity of service as "Severe" with a multiplier of 0.5.
3. Table 4-3 lists a multiplier value of 0.5 for "Vertical"
4. (Eq. 4.2) Interval = 10,000 hrs x 0.5 x 0.5 = 2500 hrs

Table 4-4 shows that 1.5 in<sup>3</sup> of grease is to be added.

Relubricate every 2,500 hrs of service with 1.5 in<sup>3</sup> of recommended grease.

#### 4.3 TROUBLE-SHOOTING

##### WARNING: READ INSTRUCTIONS:

Before trouble-shooting a motor, carefully read and fully understand the warnings, cautions, & safety notice statements in this manual.

##### WARNING: Hazardous Locations Motor Repair:

Motors nameplated for use in Division 1 Hazardous Locations can only be disassembled, modified or repaired by the plant of manufacturer or a facility that is Listed under UL's category "Motors and Generators, Rebuilt for use in Hazardous Locations". Failure to follow these instructions could result in serious personal injury, death and/or property damage

##### CAUTION: DISASSEMBLY APPROVAL REQUIRED:

Motor disassembly must be performed by a party approved by the motor manufacturer. To disassemble the motor without approval voids the warranty.

##### 4.3.1 GENERAL TROUBLE-SHOOTING WARNINGS

1. DISCONNECT POWER TO THE MOTOR BEFORE PERFORMING SERVICE OR MAINTENANCE.
2. Discharge all capacitors before servicing motor.
3. Always keep hands and clothing away from moving parts.
4. Be sure required safety guards are in place before starting equipment.
5. If the problem persists contact the manufacturer.

### 4.3.2 Motor Trouble-shooting Cause / Corrective Action - Table 4-5

Issue:	Likely Cause:	Corrective Action:
<b>Motor fails to start upon initial installation:</b>		
A.)	Supply voltage is too low or is severely unbalanced (one phase is low or missing).	(1) Check power supply fuses (2) Match motor lead wiring to nameplate connection diagram and supply voltage (3) Ensure that steady state supply voltage at motor terminals is within limits (see section 3.4.1.3). Correct as needed (4) Obtain correct motor to match actual supply voltage.
B.)	Motor leads are miswired at conduit box.	
C.)	Driven load exceeds motor capacity	(1) Verify that motor & load turn freely (2) Disconnect motor from load & ensure motor turns freely. Note: Roller bearings make noise when motor is uncoupled and shaft is rotated (3) Verify that motor starts when disconnected from load (4) Remove excessive / binding load if present.
D.)	Load is jammed.	
E.)	Fan guard is bent and making contact with fan	Replace fan guard & fan (if blades are damaged)
F.)	VFD with power factor capacitors installed	Remove power factor correction capacitors if equipped
G.)	VFD with motor neutral lead grounded	Ensure that motor neutral lead is ungrounded
H.)	VFD programmed incorrectly	(1) Repeat checks listed above (2) Verify that VFD current limit and starting boost are set correctly (5) Double-check motor and feedback parameter settings and VFD permissives (6) Repeat autotune (for vector drives) procedure (7) Consult VFD supplier.
<b>Motor has been running, then slow down, stalls, or fails to restart:</b>		
A.)	Supply voltage has drooped or has become severely unbalanced	(1) Replace fuse or reset circuit breaker. Allow motor to cool down before resetting manual protector on motor. <b>Warnings</b> - See section 1.1 for automatic and manual reset protector warnings (2) Verify that rated and balanced supply voltage has been restored before restarting motor. Measure voltage during restart. Ensure that steady state supply voltage at motor terminals is within limits (see section 3.4.1.3).
B.)	Motor is overloaded	(1) Verify that motor & load turn freely. Repair binding components as needed (2) Reduce driven load to match motor capacity or increase motor size to match load requirements.
C.)	Motor bearings are seized	
D.)	Load is jammed.	(1) Check fault codes on VFD and follow VFD troubleshooting procedures (2) Verify that VFD input voltage is balanced and within limits (3) Remove excessive mechanical load if present.
E.)	VFD will not restart motor after tripping	
F.)	Capacitor failure on single phase motor (if equipped)	<b>Warning: Potential Shock Hazard:</b> Contact service shop to check capacitor.
<b>Motor takes too long to accelerate:</b>		
A.)	Motor leads are not connected correctly	Match motor lead wiring to nameplate diagram.
B.)	Supply voltage has drooped or become severely unbalanced.	(1) Ensure that steady state supply voltage at motor terminals is within limits (see section 3.4.1.3). Correct as needed (2) Obtain correct motor to match actual supply voltage.
C.)	Load exceeds motor capability	Determine correct motor size and contact motor representative to obtain replacement motor.
D.)	Faulty start capacitor (Single Phase)	Motor may be too small for load. Record acceleration time. Start capacitors may fail if acceleration time exceeds 3 seconds.
E.)	Mechanical Failure	(1) Check to make sure motor & load turn freely (2) Disconnect motor from load & ensure motor turns freely
<b>Motor rotates in the wrong direction:</b>		
A.)	Incorrect wiring connection at motor	[Single Phase] Reconnect motor according to wiring schematic provided. Note: Some motors are non-reversible [Three Phase] Interchange any two power supply (phase) leads.
<b>Motor overheats or overload protector repeatedly trips</b>		
A.)	Driven Load is excessive	(1) If motor current exceeds nameplate value, ensure that driven load has not increased. Correct as needed. (2) If new motor is a replacement, verify that the rating is the same as the old motor. If previous motor was a special design, a general purpose motor may not have the correct performance.
B.)	Ambient temperature too high	Most motors are designed to operate in an ambient up to 40 °C. (See section 4.2.2 Hot Surface Caution)
C.)	Motor cooling fins and/or vent openings blocked	Remove foreign materials – clear vent openings, fan guard air inlets and frame fins (TEFC motors)
D.)	Insufficient Air Flow	TEAO (Totally Enclosed Air Over) motors: Measure airflow next to motor surface and obtain minimum requirements from motor manufacturer.

E.)	Motor is started too frequently	See section 3.4.5.3
F.)	Supply voltage too low, too high, or unbalanced	(1) Ensure that steady state supply voltage at motor terminals is within limits (see section 3.4.1.3) Correct as needed (2) Reconnect motor per input voltage (3) Obtain correct motor to match power supply.

### Motor Vibrates

A.)	Motor misaligned to load.	Realign load
B.)	Load out of balance (Direct drive application)	(1) Ensure that load is dynamically balanced: (2) Remove motor from load and inspect motor by itself. Verify that motor shaft is not bent. Rule of thumb is 0.002" runout for shafts extension lengths up to 3.00". Add 0.0005" per every additional inch of shaft length beyond 3.00".
C.)	Uneven tension on multiple belts	Mixing new with used belts. Replace multiple belt applications with a complete set of matched belts.
D.)	Driven load operating at resonant point / natural frequency.	(1) De-energize motor and record vibration as load coasts from 100% speed to 0 RPM. If vibration drops immediately, vibration source is electrical. If levels do not drop immediately, source is mechanical (2) Redesign system to operate below the resonant point (3) On VFD-driven loads, program skip frequencies to bypass resonant points (4) Increase carrier frequency to obtain <3% THD current (5) On variable torque loads reduce volts/hertz below base speed.
E.)	VFD torque pulsations	(1) Adjust VFD to obtain <3% THD current @ rated motor current (2) Adjust VFD stability for smooth operation. Vector drives may be unstable at light load.
F.)	Motor miswired at terminal box	Match motor lead wiring to nameplate connection diagram.
G.)	Uneven, weak or loose mounting support.	Shim, strengthen or tighten where required.
H.)	Motor bearings defective	Test motor by itself. If bearings are bad, you will hear noise or feel roughness. Roller bearings are normally noisy when operated without load. If sleeve bearing, add oil per nameplate instructions. For motors with regreasing provisions, add grease per relubricating instructions (see section 4.2.3). If noise persists contact warranty service.
I.)	Motor out of balance	Disconnect from load. Set motor on rubber pads on solid floor. Secure a ½ height key in shaft keyway and energize from balanced power supply @ rated voltage. Record vibration levels and compare with appropriate standards. If excessive vibration persists contact motor manufacturer.

### Bearings repeatedly fail.

A.)	Load to motor may be excessive or unbalanced	(1) If belt drive check system per section 3.3.4. (2) Other than belting, check loading on motor shaft. An unbalanced load will also cause the bearings to fail. (3) Check runouts of mating components, such as a C-face and pump flange.
B.)	Bearings contaminated.	Motor enclosure not suitable for environment. Replace with correct enclosure construction
C.)	Incorrect grease or bearings for ambient extremes.	See section 4.2.1
D.)	VFD bearing damage	Ground brush, common mode filter, or insulated bearings must be added. Contact motor manufacturer.

### Motor, at start up, makes a loud rubbing, grinding, or squealing noise.

A.)	Contact between rotating and stationary components	Belt squeal during across the line starting is normal: (1) Verify that supply voltage is within limits (see section 3.4.1.3). (2) Ensure that motor lead wiring matches nameplate connection diagram: (3) Isolate motor from load. (4) To locate point of contact turn motor shaft by hand. (5) If point of contact is not located contact motor service shop.
-----	--	--

### Start capacitors repeatedly fail.

A.)	The motor acceleration time is too long	Motor may be too small for load. Record acceleration time. Start capacitors may fail if acceleration time exceeds 3 seconds.
B.)	Motor is being started too frequently	Excessive starting will damage motor capacitors. Contact motor manufacturer if motor is started more than 20 times/hour or if acceleration time exceeds 3 seconds.
C.)	Motor voltage low	Verify that voltage at the motor terminals is within limits (see section 3.4.1.3).
D.)	Defective start switch inside motor	Motor internal switch failure overheats start capacitor. Contact service shop or motor manufacturer.

### Run capacitor fails.

A.)	High ambient temperature	Verify that the ambient does not exceed motor's nameplate value
-----	--------------------------	---

	<b>B.)</b> Input voltage exceeds limit	Verify that voltage to the motor terminals is within limits (see section 3.4.1.3).
	<b>C.)</b> Power surge to motor (caused by lightning strike or other high transient voltage).	If a common problem, install surge protector.

## NOTES