



# **OPERATOR'S MANUAL**

## **1448 Haul Unit System**

**Haul Unit S/N: F21800F**

**Publication No. 050008A00**

Rev. No. 030120 R100630

© Akkerman Inc. 2003  
All Rights Reserved

Akkerman Inc. 58256 266th Street Brownsdale, MN 55918  
Phone: 507-567-2261 Fax: 507-567-2605 email: [akk@akkerman.com](mailto:akk@akkerman.com)

**SERVICE • RELIABILITY • INNOVATION**



# Introduction

This operator's manual contains important safety, operation, and maintenance information for your Akkerman 1448 Haul Unit System. This system includes the 1448 Haul Unit, Dirt Bucket, Haul Cart, and Track. You must read and understand this manual before you operate and maintain this equipment. Keep this manual with your Haul Unit at all times. Additional copies of this manual may be purchased from the Akkerman Aftermarket Support Department, or downloaded from the Akkerman web site at [www.akkerman.com](http://www.akkerman.com).

The contractor is responsible for the overall safety program on the job site. Use this manual as a part of the safety program.

The use of second rate parts could affect the efficient performance of the Haul Unit System. ALWAYS use genuine Akkerman parts.

Understand safety signal words, DANGER, WARNING, CAUTION, SAFETY INSTRUCTIONS, and NOTICE. When you see these words in this manual or on safety decals mounted on your equipment, follow the safety message to avoid personal injury and/or property damage.

**▲ DANGER** Indicates an extremely hazardous situation which, if not avoided, WILL result in death or serious injury.

**▲ WARNING** Indicates a potentially hazardous situation which, if not avoided, COULD result in death or serious injury.

**▲ CAUTION** Indicates a potentially hazardous situation, which, if not avoided, MAY result in minor or moderate injury. It may also be used to alert against unsafe practices.

**SAFETY INSTRUCTIONS** Usually consists of individual messages stating procedures or actions that must be followed for the safe operation of a product.

**NOTICE** Identifies potential property damage and important installation, operator, or maintenance information.

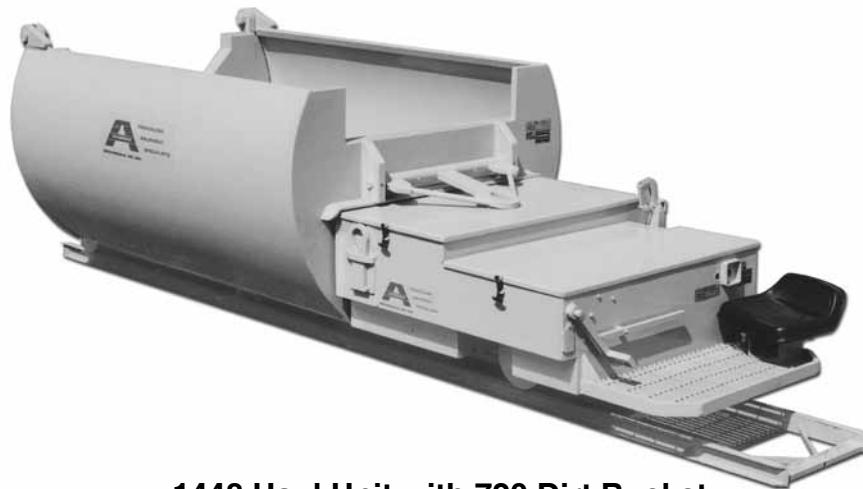

**1448 Haul Unit with 720 Dirt Bucket**

The 1448 Haul Unit System transports the spoil from the Tunnel Boring Machine back to the launch shaft. The typical Akkerman system is comprised of a haul unit, track and dirt bucket. Multiple-bucket train systems (utilizing the haul cart) are available to increase productivity on long tunnels or pushes. The 1448 haul unit is electro-hydraulically powered with a removable battery pack, and equipped with hydraulic disc brakes.

Dirt buckets are designed for maximum capacity based on the size of pipe or tunnel being installed. They are self-dumping when using a two-line crane or by attaching a stationary line.

The track sections are lightweight, yet sturdy. The tracks are quick to connect with a single bolt and wing nut. Storage racks are available for convenient shipping and handling.

If you find any errors with this manual or know of ways to improve procedures, please let us know. Mail your suggestions to: ATTN: Technical Publications  
Akkerman Inc, 58256 266th Street, Brownsdale, MN 55918

Akkerman Inc. reserves the right to improve its product without notice or obligation.

# Contents

<b>Safety</b> .....	<b>1</b>	<b>Periodic Maintenance</b> .....	<b>9</b>
Be Alert For Safety Information .....	1-1	Lockout Power Before Servicing .....	9-1
Read Operator's Manual .....	1-1	Maintenance Charts .....	9-2
Wear Protective Clothing .....	1-1	Daily or Every 10 Hours or Shift Change ...	9-2
Fire Prevention .....	1-2	Weekly or Every 50 Hours .....	9-3
Maintain Battery Safely .....	1-2	Monthly or Every 250 Hours .....	9-4
Hydraulic Oil/Fluids Under Pressure .....	1-2	Every 500 Hours Or When Engulfed W/Water ..	9-5
Keep Riders Off Haul Unit .....	1-3	Maintenance Procedures .....	9-6
Regularly Clean/Inspect Equipment .....	1-3	Daily or Every 10 Hours or Shift Change ...	9-6
Practice Safe Maintenance .....	1-3	Weekly or Every 50 Hours .....	9-11
Beware of Suspended Loads .....	1-4	Monthly or Every 250 Hours .....	9-16
Avoid Tunnel Wall Contact .....	1-4	Every 500 Hours Or Engulfed With Water	9-21
Lockout Power Before Servicing .....	1-4	<b>Storage</b> .....	<b>10</b>
Test Tunnel Ventilation .....	1-5	<b>Troubleshooting</b> .....	<b>11</b>
Keep Away From Conveyors .....	1-5	General Troubleshooting .....	11-1
Watch for Conveyor .....	1-5	Haul Unit Electrical Schematic .....	11-3
No Smoking In Tunnel .....	1-6	Haul Unit Hydraulic Schematic .....	11-4
Avoid Laser Light Exposure .....	1-6	<b>Specifications</b> .....	<b>12</b>
Recycle Waste .....	1-6	General Specifications .....	12-1
Unauthorized Welding .....	1-6	Torque Chart .....	12-2
Slippery When Wet .....	1-7	<b>Identification Numbers</b> .....	<b>13</b>
Keep Job Site Clean & Organized .....	1-7	<b>Material Safety Data Sheets</b> .....	<b>14</b>
<b>Safety Decals</b> .....	<b>2</b>	<b>Warranty</b> .....	<b>15</b>
<b>Terminology</b> .....	<b>3</b>	<b>Index</b> .....	<b>16</b>
<b>Controls &amp; Instruments</b> .....	<b>4</b>		
Controller .....	4-1		
Brake .....	4-1		
Battery Charge Indicator .....	4-1		
Hydraulic Filter Indicator .....	4-2		
<b>Pre-Start Inspection</b> .....	<b>5</b>		
<b>Operation</b> .....	<b>6</b>		
Operating Guidelines .....	6-1		
Setting Up The Haul Unit .....	6-2		
Installing Track .....	6-3		
Operating The Haul Unit .....	6-4		
Stopping The Haul Unit .....	6-6		
Parking The Haul Unit .....	6-6		
Using the Haul Cart .....	6-6		
Using the Dirt Bucket .....	6-7		
Moving Frame Extension For Bucket Config ..	6-9		
Recharging The Battery Pack .....	6-10		
<b>Transporting</b> .....	<b>7</b>		
<b>Lubricants</b> .....	<b>8</b>		
Gear Box Lubricant .....	8-1		
Hydraulic Reservoir Lubricant .....	8-1		
Brake Fluid .....	8-1		
Grease .....	8-2		
Storing Lubricants .....	8-2		

# Safety

---

## BE ALERT FOR SAFETY INFORMATION

When you see this safety alert symbol on your equipment or in this manual, be alert to the possibility of personal injury or property damage.

Read all safety information.

Keep safety decals clean and in good condition.  
Replace missing or damaged safety decals.



**ATTENTION!  
BECOME ALERT!  
YOUR SAFETY IS INVOLVED!**

---

## READ OPERATOR'S MANUAL

**⚠ WARNING** Unsafe operation or maintenance can cause severe injury or death.

Read and understand the Operator's Manual before operating or servicing this equipment.

Any unauthorized modifications will void the warranty.

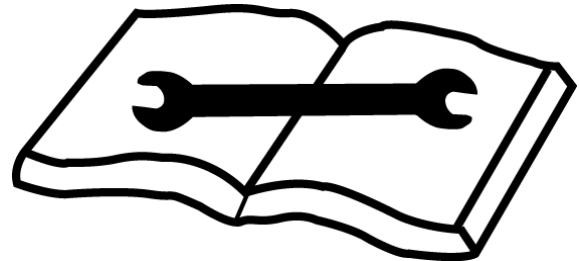

---

## WEAR PROTECTIVE CLOTHING

Wear OSHA approved protective clothing, such as hard hat, gloves, safety goggles, earmuffs or ear plugs, face shield, and steel-toed boots, when operating and servicing this equipment.

Wear reasonably close fitting clothing and remove jewelry before working on or near this equipment. This will help prevent the danger of catching them in moving parts or controls.



---

## FIRE PREVENTION

**⚠ CAUTION** Fires can cause injury or property damage.

Keep equipment clean. Remove all debris from equipment.

Have a fire extinguisher available at all times. Keep the fire extinguisher fully charged.



---

## MAINTAIN BATTERY SAFELY

**⚠ WARNING** Batteries produce explosive gases.

Wear eye protection and protective clothing during battery service.

Keep sparks, flames, and cigarettes away from batteries.

Contact with battery acid can cause severe burns. Flush immediately and thoroughly with clean water. Get medical attention immediately.

Charge a battery only in a well-ventilated area.

Never charge a frozen battery.

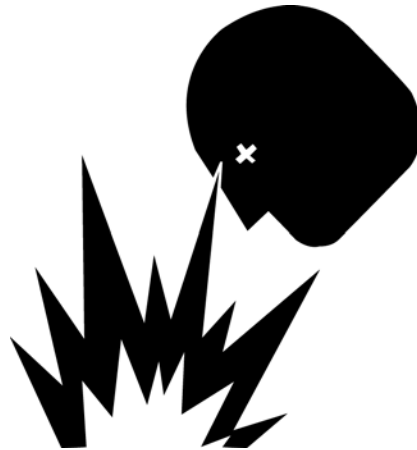

---

## HYDRAULIC OIL/FLUIDS UNDER PRESSURE

**⚠ WARNING** Escaping oil or other fluids under pressure can penetrate your skin causing serious injury.

Release all pressure before performing maintenance or repairs. Never weld near pressurized fluid lines.

DO NOT use your hands to check for leaks. When searching for leaks, use a piece of wood or cardboard.

Contact medical help immediately if any oil or fluid is injected into your skin. A serious infection or reaction can emerge without proper medical treatment.



---

## KEEP RIDERS OFF HAUL UNIT

Allow only operator on operating seat when moving haul unit. Keep riders off.

Riders on haul unit can be easily injured by being struck by objects or being thrown off of the equipment. Riders can also obstruct the operator's view resulting in the equipment being operated in an unsafe manner.

A rider may be allowed in an empty dirt bucket (with contractor approval only), to transport personnel from the tunnel opening to the boring head. If allowed, the rider **MUST** be fully inside dirt bucket, including head and all other body parts, to avoid contact with obstructions. Also, rider cannot obstruct the operator's view.

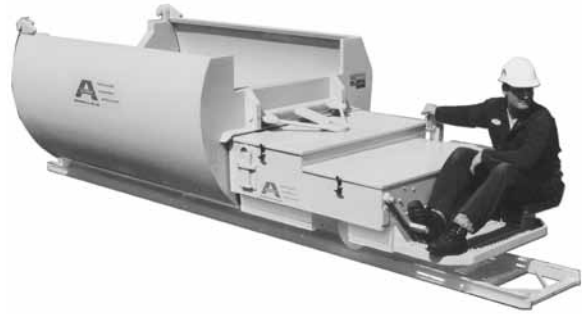

---

## REGULARLY CLEAN AND INSPECT EQUIPMENT

Remove any grease, oil, or debris buildup to avoid potential injury or equipment damage.

Inspect equipment for damage. If damaged, repair or replace immediately.

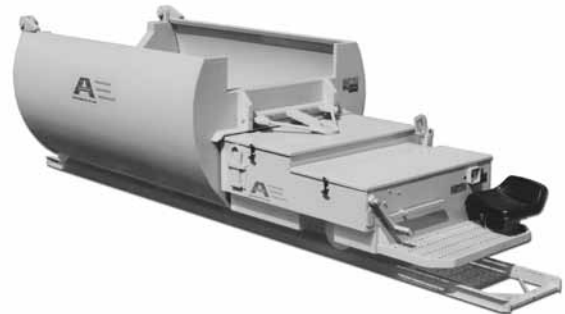

---

## PRACTICE SAFE MAINTENANCE

LOCKOUT power before performing any maintenance by disconnecting battery harness from contactor harness and removing battery pack from haul unit.

Only trained and qualified personnel should perform any maintenance or repairs.

Keep the area around the equipment clean and dry when performing maintenance.

Do not service the machine while it is in motion.

Replace worn or damaged parts. Remove grease, oil, or debris buildup.



---

## BEWARE OF SUSPENDED LOADS

**⚠ WARNING** Suspended loads may fall and cause severe personal injury or death.

If a hydraulic hose, chain, or cable from the boom of a crane or excavator breaks, the boom and/or load can fall instantly.

Do not enter area under or around a load.



---

## AVOID TUNNEL WALL CONTACT

**⚠ WARNING** Contacting tunnel wall and boring head components can cause severe personal injury or death.

Keep all body parts on Haul Unit while Unit is moving (as shown in photograph).



---

## LOCKOUT POWER BEFORE SERVICING

**⚠ WARNING** Failure to lockout power before servicing can cause severe personal injury or death.

LOCKOUT power before performing any maintenance by disconnecting battery harness from contactor harness and removing battery pack from haul unit.



---

## TEST TUNNEL VENTILATION

**⚠ WARNING** Keep Boring Head and tunnel well ventilated at all times.

Use an approved air analyzer to detect hazardous gases and oxygen content.

Before and during the tunnel operation, test for combustible and toxic gases and oxygen deficiency.

If the levels exceed OSHA prescribed levels, leave tunnel immediately! Do not activate or deactivate any electrical or hydraulic devices, since any sparks can cause an explosion.

Once ALL personnel are out of tunnel, cut power from power source.

Gases must be removed before reentering tunnel.

Do not use Haul Unit to evacuate the tunnel. The electrical contacts with the unit can cause an explosion.

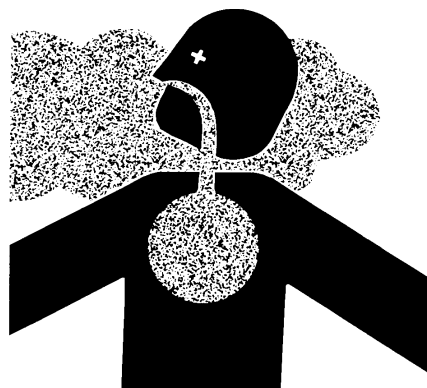

---

## KEEP AWAY FROM CONVEYORS

**⚠ DANGER** Contact with rotating auger conveyor or conveyor belt idler rollers, will cause severe injury or death.

Keep hands, body, and objects clear of operating auger and conveyor.

Do not operate without covers and guards in place.

Lockout power before servicing.

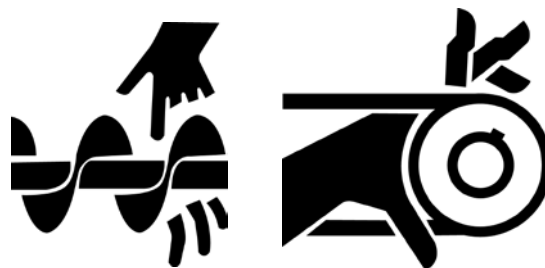

---

## WATCH FOR CONVEYOR

**⚠ WARNING** Avoid contact with conveyor. Failure to do so could cause severe injury or death.

While moving haul unit into tunnel, avoid hitting the conveyor.

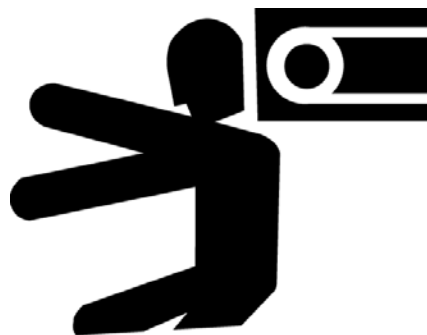

---

## NO SMOKING IN TUNNEL

**⚠ WARNING** Smoking in tunnel could cause an explosion if combustible gases are present.

Do not smoke in tunnel.



---

## AVOID LASER LIGHT EXPOSURE

**⚠ DANGER** Staring into laser light will cause severe injury.

Do not stare into laser guidance system light beam. Avoid direct eye exposure.

To avoid possible exposure to radiation in excess of acceptable emission limits, all repairs to laser must be performed by the original manufacturer or an authorized service technician.

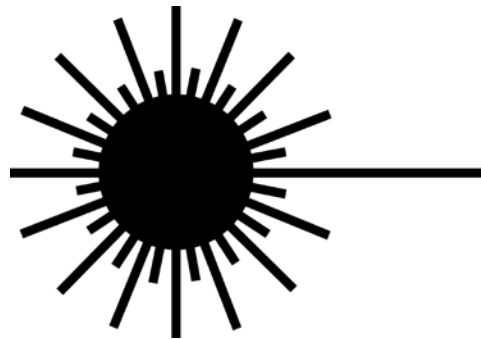

---

## RECYCLE WASTE

Follow local, state, federal, and international regulations when recycling or disposing of waste. Waste includes fluids/oil, fuel, filters, coolant, and batteries.

Use leakproof containers when draining fluids/oil. Do not pour waste on the ground, down a drain, or into any water source.

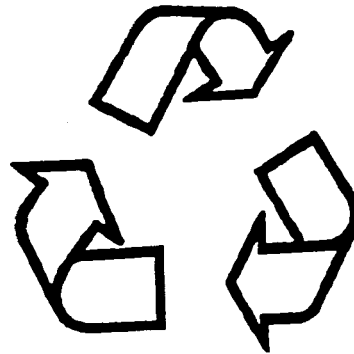

---

## UNAUTHORIZED WELDING

**⚠ WARNING** Unauthorized welding can cause structural failure and/or electrical system damage resulting in possible injury or death.

Do not weld on any structural member. Unauthorized welding or repair will void the warranty.

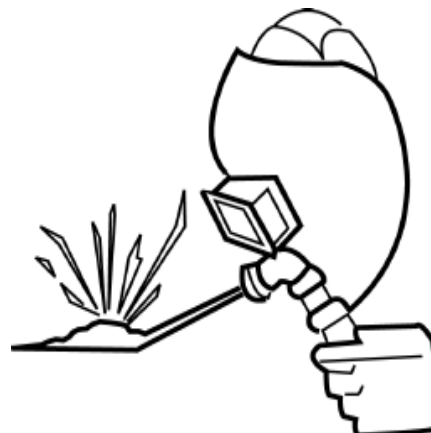

---

## SLIPPERY WHEN WET

**⚠ WARNING** Slips and falls can cause serious personal injury.

Ensure firm footing in wet or slippery conditions.

Replace skid-resistant material if it is damaged or missing to prevent slips and falls.

Remove any buildup of grease, oil, or debris.



---

## KEEP JOB SITE CLEAN AND ORGANIZED

**⚠ WARNING** Tripping can cause serious personal injury.

Be sure to keep job site clean and organized.



## **NOTES**

# Safety Decals

Keep all safety decals clean and readable. Use soft cloth, water, and a mild soap to clean the decals if they are too dirty to read. DO NOT clean safety decals with solvent. Solvent can damage them. Replace safety decals immediately if they are damaged, missing, or hard to read.

Serious injury or property damage can occur if safety instructions are not followed. Contact your Akkerman Product Support representative for replacement safety decals.

If a part is replaced that has a safety decal on it, apply a new safety decal to the replacement part. Before applying a new decal, be sure the surface is clean and dry.

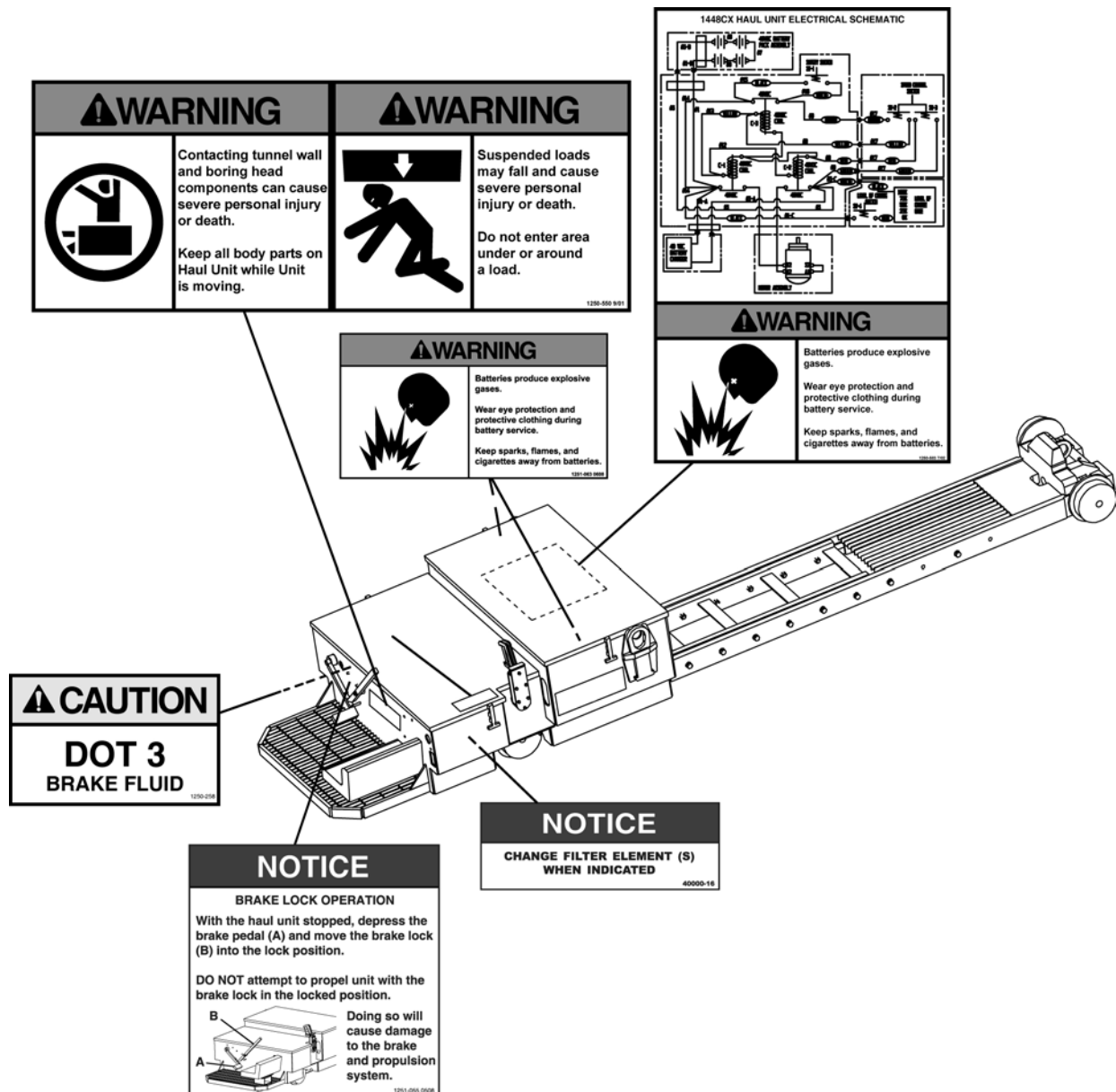

**NOTES**

# Terminology

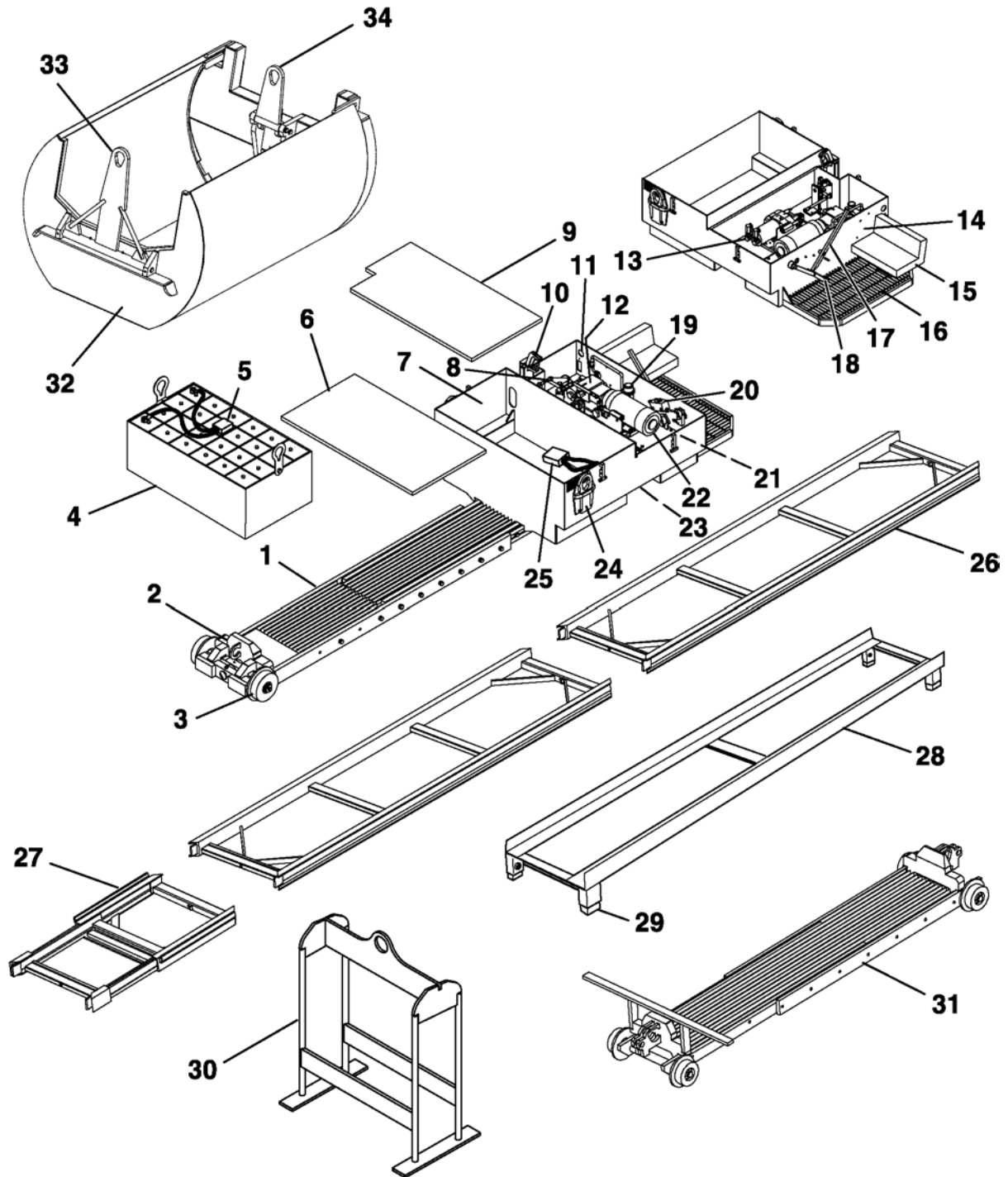

- |                              |                               |                       |
|------------------------------|-------------------------------|-----------------------|
| 1. Frame Assembly            | 13. Hydraulic Motor           | 24. Lifting Eye       |
| 2. Idler Assembly            | 14. Battery Charge Indicator  | 25. Contactor Harness |
| 3. Idler Wheel               | 15. Seat                      | 26. Track             |
| 4. Battery Pack              | 16. Operator Platform         | 27. Sliding Track     |
| 5. Battery Harness           | 17. Brake Lock                | 28. Track Riser       |
| 6. Battery Compartment Cover | 18. Brake Pedal               | 29. Riser Bar         |
| 7. Battery Compartment       | 19. Hydraulic Filler/Breather | 30. Track Carrier     |
| 8. Throttle Linkage Assembly | 20. Master Cylinder           | 31. Haul Cart         |
| 9. Drive Box Cover           | 21. Contactors                | 32. Dirt Bucket       |
| 10. Controller               | 22. Electric Motor            | 33. Bucket Lift Eye   |
| 11. Filter Indicator         | 23. Drive Wheels              | 34. Door Lift Eye     |
| 12. Hydraulic Pump           |                               |                       |

## **NOTES**

# Controls & Instruments

## CONTROLLER

The Controller controls the direction and speed of travel.

Activate the controller by depressing motor switch (A) then slowly move the controller handle (B) towards the desired direction of travel to propel haul unit.

The haul unit will propel faster the farther the control handle is moved away from the center or neutral position.

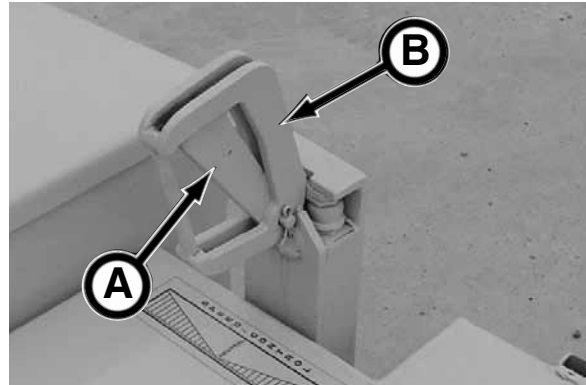

## BRAKE

Release or return the control handle to the center (neutral) position and depress the brake pedal (C) to stop the haul unit.

**CAUTION** Be careful when stopping the haul unit as the forward momentum can carry the unit past the point where the brake is applied.

**NOTICE** Do not try to stop the haul unit by moving the control handle in the opposite direction. Damage to the hydrostatic components could occur.

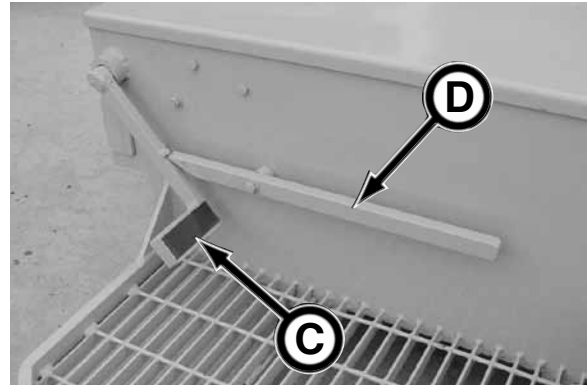

### BRAKE LOCK

To park your haul unit or to avoid any unintended movement, engage the brake lock (D) by depressing the brake pedal and moving brake lock arm down until it is locked into position.

## BATTERY CHARGE INDICATOR

Depress button (E) to view the battery charge level on the battery indicator (F). If the indicator needle is in the red zone, recharge the battery.

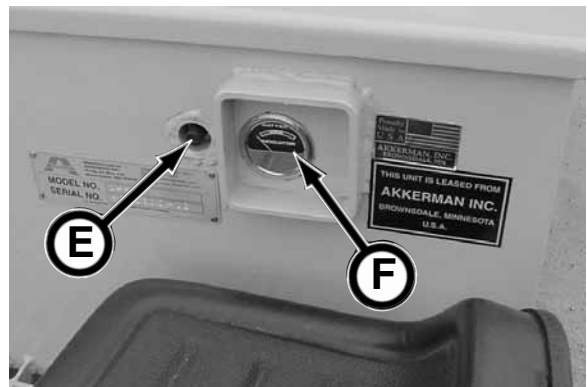

## HYDRAULIC FILTER INDICATOR

To prevent under or over servicing of the hydraulic filter element, a filter indicator gauge has been installed on your 1448 Haul Unit.

The green OK zone indicates that the filter is functioning properly.

The yellow zone indicates that the filter will soon require replacement.

Replace filter when the needle on the gauge is in the red CHANGE zone.

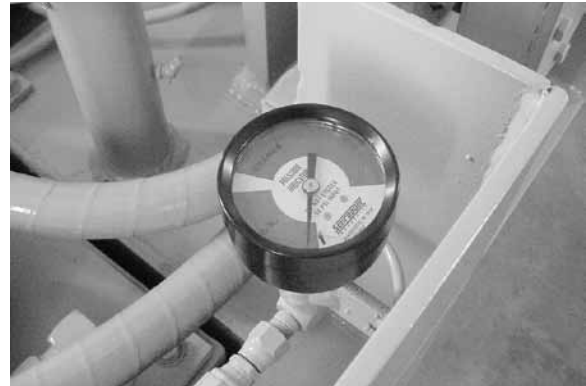

### **NOTICE**

The hydraulics must be in operation for the gauge to function.

# Pre-Start Inspection

## **⚠ WARNING**

Do not operate this equipment until you read, study, and understand this manual. A daily inspection of the equipment must be performed to prevent severe personal injury or death and equipment damage.

The contractor is fully responsible for the safety of all personnel on the job site. Check with the contractor that all site preparation requirements are in place. Be sure to comply with all OSHA regulations, such as: an active safety program is in practice, a confined space permit (if needed) is issued, personal protective equipment is being worn; flammable, combustible, and hazardous materials are properly stored; and a lockout/tagout procedure is in place.

Use the following checklist ✓ as a guide for your daily pre-start inspection or shift change.

	1. Use "ONE-CALL" notification to check for buried utility lines prior to tunneling.
	2. Contractor is responsible for all personnel to wear proper protective equipment on the job site. Replace equipment if defective.
	3. Check the excavated launch and reception shafts for proper shoring or bracing to prevent slides or cave-ins.
	4. Thoroughly clean equipment of mud and dirt.
	5. Remove combustible or flammable materials from equipment. Store materials properly.
	6. Test air monitoring and ventilation detectors for proper operation.
	7. Inspect track, haul unit, and dirt bucket for damage. Repair or replace as needed.
	8. Check to be sure each track section joint is properly fastened.
	9. Check haul unit drive wheels for damage. If damaged, replace wheels.
	10. Be sure all covers and guards are in place before operation.
	11. Check that the self-dumping dirt bucket door moves freely and operates correctly.
	12. Practice operating the haul unit to get the "feel" of the equipment. Check for speed and braking technique.
	13. Check to be sure the brake fluid in the master cylinder is properly filled. Use only DOT 3 Brake Fluid.
	14. Check to be sure brakes engage and release properly.
	15. Check to be sure the brake lock works properly.
	16. Check to be sure controller works properly before operating. Repair or replace as needed.
	17. Check controller for damage. Repair or replace as needed.
	18. Check battery electrolyte level. Refer to battery manufacturer instructions.
	19. Check hydraulic oil level. Add hydraulic oil as needed.
	20. Check for loose or missing hardware. Replace damaged or missing hardware.
	21. Check for worn, loose, or damaged wire connections. Repair or replace wiring.
	22. Tighten loose clamps or fittings.
	23. Check battery harness and contactor harness connectors for a secured connection.
	24. Check wire harnesses for frayed or worn insulation or wires. Replace damaged or worn harnesses.
	25. Check battery charge level on haul unit before operating.
	26. Check spare battery pack for full charge. Recharge, if needed.
	27. Check for fluid leaks. Repair leak or replace hoses or components.
	28. Check condition of lift eyes on haul unit, battery pack and dirt bucket. Replace if damaged.
	29. Keep job site clean and organized.
	30. Check equipment for proper lubrication. Refer to Section 9, Periodic Maintenance.

## **NOTES**

# Operation

## OPERATING GUIDELINES

### **⚠WARNING**

Do not operate this equipment until you read, study, and understand this manual. Failure to do so, could result in severe personal injury or death.

1. Before operating, read and understand the Safety, Pre-Start Inspection, and Operation sections.
2. Do not operate this equipment while under the influence of alcohol, drugs, or medication.
3. Follow all Federal, State, and Local safety regulations and procedures.
4. Be sure OSHA prescribed safety protective equipment is being worn by all personnel.
5. Be sure the area is safe for operation. Keep worksite clean and orderly.
6. NEVER operate equipment if it has been engulfed with water. Contact your Akkerman Aftermarket Support representative for proper procedures on how to restore equipment for operation.
7. Have a fully charged fire extinguisher on the job site at all times.
8. Before operating, repair equipment problems.
9. Be sure the excavated launch and reception shafts are properly shored or braced to prevent slides or cave-ins.
10. Test air monitoring and ventilation detectors for proper operation. Never enter a tunnel without detectors.
11. A fully trained and qualified signal person must direct the excavator or crane operator when lifting and lowering the haul unit, dirt bucket, and other equipment.
12. Never walk or work under any part of the excavator or crane and suspended loads, such as pipe or dirt bucket.
13. Never operate the haul unit without being completely on the seat of the operator platform.
14. Practice operating the controls to make sure they work properly and to get the “feel” of the speed and braking of the haul unit.
15. When using haul unit to enter or exit a tunnel, watch out for personnel and do not run into obstacles.
16. No riders are allowed on the haul unit. Riders can fall from equipment or be injured by unexpected movement, resulting in severe injury or death. A rider may be allowed in an empty dirt bucket (**with contractor approval only**), to transport personnel from the tunnel opening to the boring head. If allowed, the rider **MUST** be fully inside dirt bucket, including head and all other body parts, to avoid contact with obstructions. Also, rider cannot obstruct the operator’s view.
17. Beware of pinch points.
18. If this manual is lost, contact your Akkerman Aftermarket Support representative for a new manual or download this manual from the Akkerman web site at [www.akkerman.com](http://www.akkerman.com).
19. Do not operate this equipment on a grade higher than 5% unloaded or 2.5% loaded. The unloaded equipment grade can be visualized by a 1/2 foot (6 in.) drop or rise in a 10 foot distance. The loaded equipment grade can be visualized by a 1/4 foot (3 in.) drop or rise in a 10 foot distance.
20. Do not operate with loose objects on the operator platform, battery compartment cover and drive box cover, such as tools or parts.

## SETTING UP THE HAUL UNIT

1. Once the Tunnel Boring Machine (TBM) has been setup with: power unit, jacking system, conveyor, and laser guidance system; install track and track risers as needed (see Installing Track in this section).



**⚠ WARNING** Suspended loads may fall and cause severe personal injury or death.

Do not enter area under or around a load.

**NOTICE** In certain applications, the dirt bucket will need to be lowered into position behind the conveyor until the TBM has moved far enough forward to allow enough room to lower the haul unit.

2. Using the lifting eyes (A), lower the haul unit without the battery pack, onto the jacking system rails or track. The operator platform end of the haul unit should be positioned towards the TBM.
3. Inspect the area for clearance between the haul unit frame and the dirt bucket unloading area.
4. Open battery compartment cover. Lower the battery pack into the haul unit and connect the battery harness (B) with the contactor harness (C). Replace battery compartment cover (D).

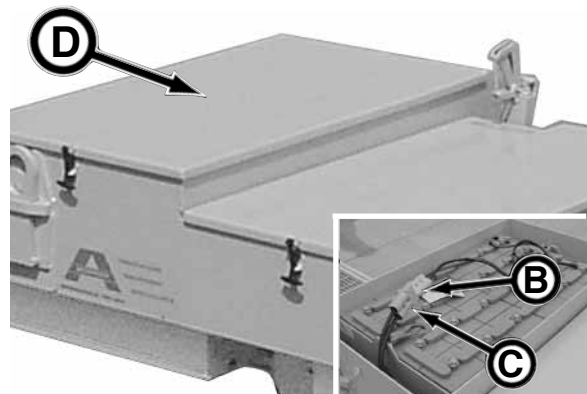
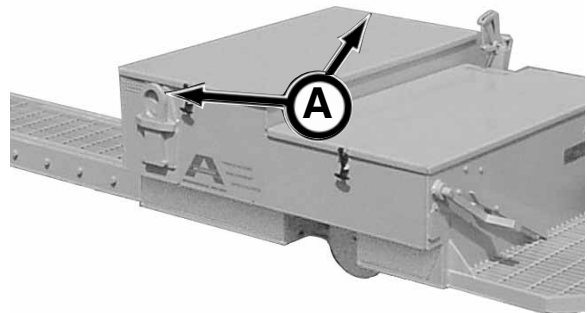

5. Lower the dirt bucket onto the haul unit rails.



## INSTALLING TRACK

1. Track sections are easily connected with a single bolt and wing nut. The first track section should be installed to the TBM.

Install additional track after the trailing pipe has been lowered on the jacking system base and mates with the leading pipe.

**NOTICE** Periodically inspect track bolts and wing nuts for tightness and damage. Retighten track bolts/wing nuts as necessary. If damaged, replace with new.



2. If track risers (A) are required, center the track risers under each track connection (B).

**NOTICE** Track risers are used to retain the track height from the TBM to the yoke.

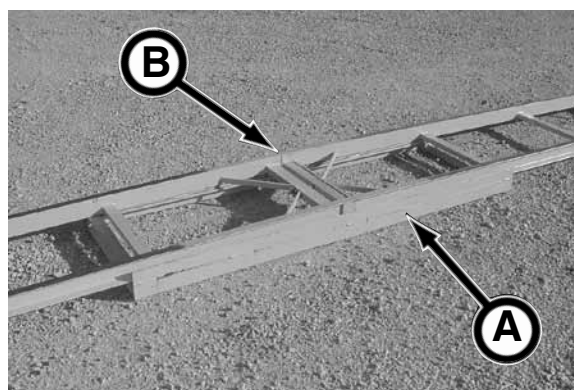

3. The sliding track will slide in and out with the movement of the intermediate jacking station (IJS). Be sure no track joints are in the IJS.

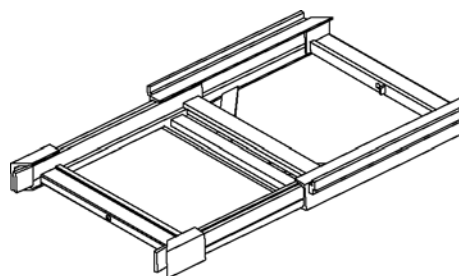

## OPERATING THE HAUL UNIT

**⚠ WARNING** Contacting tunnel wall and boring head components can cause severe injury or death. Keep all body parts on Haul Unit while Unit is moving.

**⚠ WARNING** Keep Boring Head and tunnel well ventilated at all times.

Use an approved air analyzer to detect hazardous gases and oxygen content before and during tunnel operation.

If the levels exceed OSHA prescribed levels, leave tunnel immediately! Do not activate or deactivate any electrical or hydraulic devices, since any sparks can cause an explosion.

Gases must be removed before reentering tunnel. Do not use Haul Unit to evacuate the tunnel. Doing so may cause an explosion.

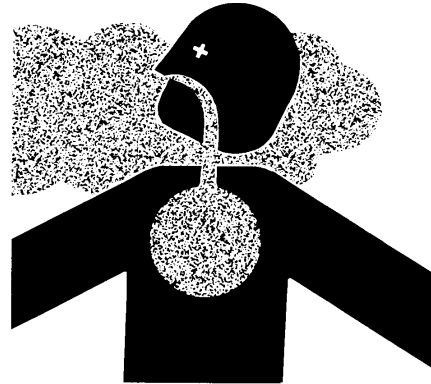

1. Mount the haul unit operator platform, sit on seat and keep all body parts are within the platform area.
2. Clear all personnel from the bucket unloading area and pipeline travel area.

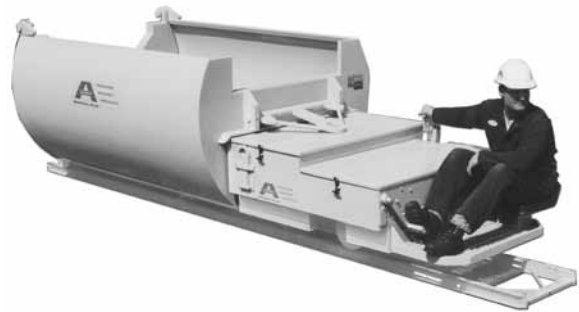

3. Release the brake by depressing the brake pedal and releasing brake lock (A).



4. Start travel into the pipeline by holding the motor switch on controller and slowly moving the controller towards the tunnel.

**NOTICE** The haul unit will propel faster the farther the control handle is moved away from the center or neutral position.



(continued on next page)

5. Release the motor switch and controller to allow coasting of the haul unit.
6. Depress brake pedal as needed to stop the haul unit. Keep in mind that forward momentum will carry the haul unit past the point where the brake is applied.

**NOTICE** Do not try to stop haul unit by moving the controller in the reverse direction of travel. Damage to the motor and/or gear box could result.

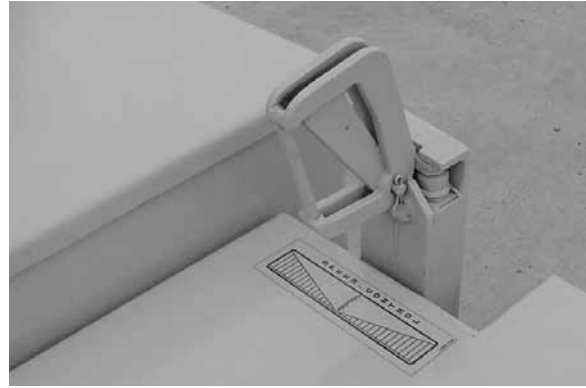

7. Apply the brake lock (A) to prevent unintended haul unit movement by depressing brake pedal and moving the brake lock into the lock position.

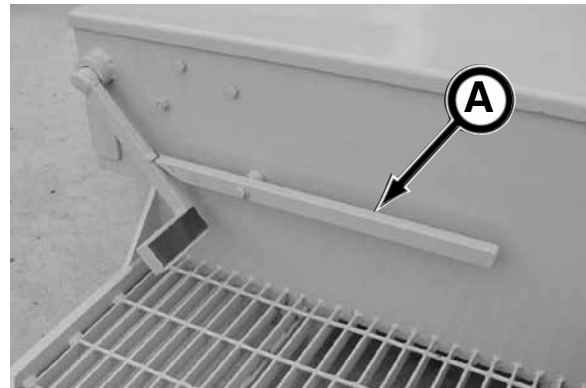

8. To move haul unit out of tunnel, release brake lock, hold motor switch on controller and slowly move the controller towards the tunnel opening. Then slowly move the haul unit into the bucket unloading area on the yoke. Use the brake as needed.

**NOTICE** Do not attempt to propel unit with the brake lock in the locked position. Damage to the brake system can occur.



## STOPPING THE HAUL UNIT

1. Release or return the control handle to the center (neutral) position.
2. Depress the brake (A) to stop the haul unit.

**CAUTION** Be careful when stopping the haul unit as the forward momentum can carry the unit past the point where the brake is applied.

**NOTICE** Do not try to stop the haul unit by moving the control handle in the opposite direction of travel. Damage to the motor and/or gear box could result.



## PARKING THE HAUL UNIT

With the haul unit stopped, depress the brake pedal (B) and move the brake lock (C) into the lock position.

**NOTICE** Do not attempt to propel unit with the brake lock in the locked position. Damage to the brake and propulsion systems can occur.

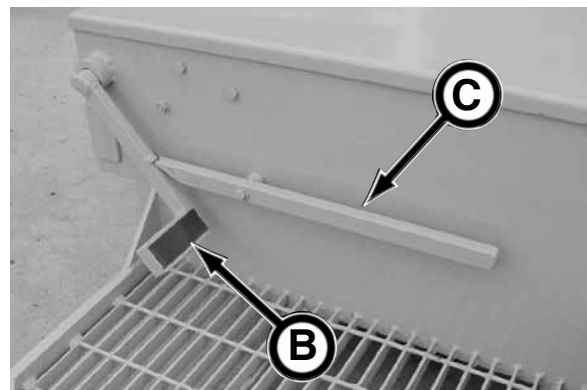

## USING HAUL CART

Increase your haul unit productivity on long tunnels or pushes with a multiple-dirt bucket train system by pinning the haul cart (with dirt bucket) to the 1448 Haul Unit.

**NOTICE** If utilizing a multiple-dirt bucket train system, note that the extra load will reduce the operational grade, and the haul unit will take longer to start and stop.

If you need to switch the haul cart from standard to the extended dirt bucket configuration, or vice versa, simply remove all bolts, lock washers, and nuts, slide frame to desired standard (60") or extended (90") dirt bucket size, and replace the hardware.

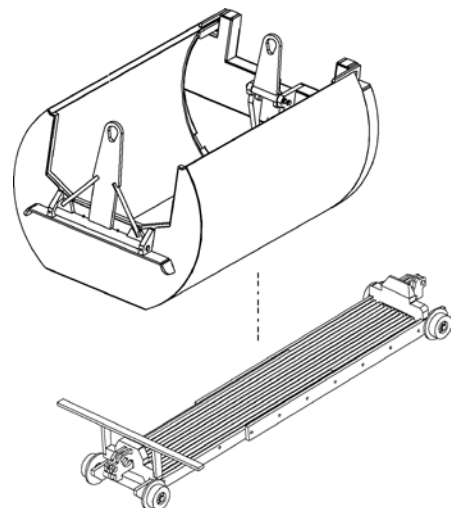

## USING THE DIRT BUCKET

**NOTICE** To switch haul unit frame for the standard or extended bucket, refer to Moving The Frame Extension For Standard & Extended Dirt Bucket Configuration in this section.

1. With the dirt bucket lowered onto the haul unit's rails, lower the bucket lift eye so it will not interfere with conveyor.



**WARNING** Avoid contact with conveyor. Failure to do so could cause severe injury or death.

2. Move the haul unit into the tunnel. The dirt bucket must be positioned behind the conveyor to contain the spoil.



3. When the dirt bucket is full, move the haul unit/ dirt bucket out of the tunnel until the dirt bucket clears the tunnel wall to the unloading area.

4. Flip the bucket lift eye up.



**⚠ WARNING**

Suspended loads may fall and cause severe personal injury or death. Do not enter area under or around a load.

5. With a crane or excavator, check for clearances and carefully lift the dirt bucket out of unloading area and move to dumping site.

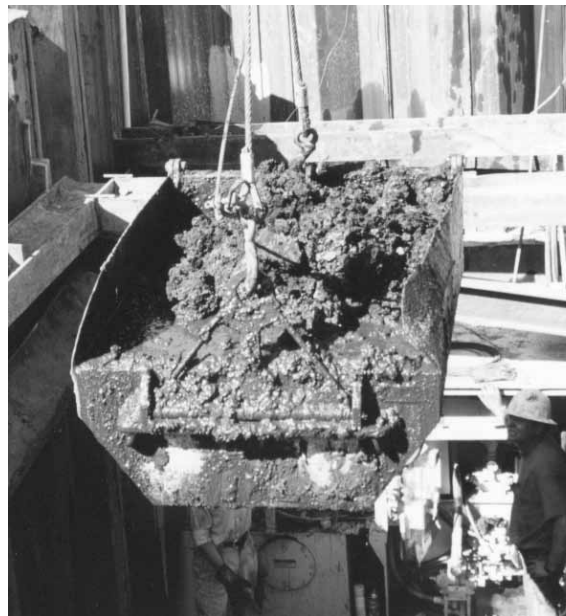

6. Unload dirt bucket. The dirt bucket is self-dumping when using a two-line crane or when attaching a stationary line.



7. After dirt bucket is empty, move the dirt bucket to the unloading area and lower onto haul unit rails.

8. Lower bucket lift eye.

9. Follow steps 2 through 8 until the tunnel is complete.

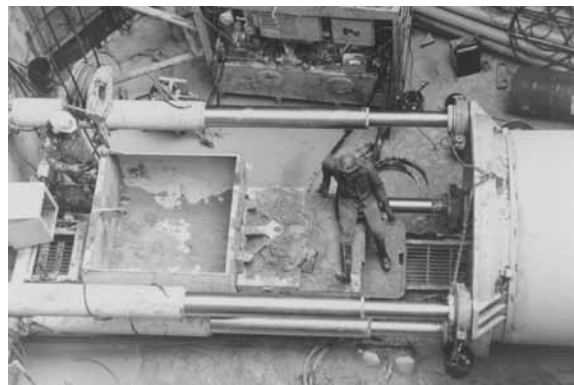

10. After tunnel is complete, flip the bucket eye up (see inset), and lift the dirt bucket out of shaft or pit area.



## MOVING THE FRAME EXTENSION FOR STANDARD & EXTENDED DIRT BUCKET CONFIGURATION

### NOTICE

The grate (A) is used only with the extended dirt bucket (90"). The grate is stored when the haul unit is configured for the standard dirt bucket (60").

1. Securely support haul unit frame so the frame extension (B) can be slid forward or back depending on whether you are switching to the standard or extended dirt bucket.
2. Remove all bolts, lock washers, and nuts. Retain hardware for later use.
3. (For Standard Bucket) Remove and store grate for future extended bucket configuration.
4. Slide frame extension forward or back so the 60" or 90" dirt bucket will fit properly on the frame.

For Standard Bucket, continue to step 6.  
For Extended Bucket, continue to step 5.

5. (For Extended Bucket)

Place grate (A) onto frame extension and secure with four 5/8-11 UNC x 3 in. bolts, lock washers, and nuts (C).

Secure frame extension to haul unit frame with twelve 5/8-11 UNC x 4 in. bolts, lock washers, and nuts (D).

6. (For Standard Bucket)

Secure frame extension to haul unit frame with twelve 5/8-11 UNC x 4 in. bolts, lock washers, and nuts (D).

Secure frame extension to haul unit frame (below battery box) with six 5/8-11 UNC x 5 in. bolts, lock washers, and nuts (E).

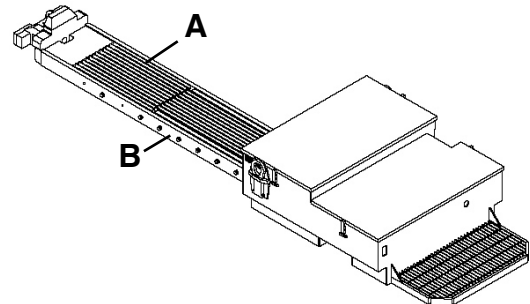

*Extended Haul Unit - Top View*

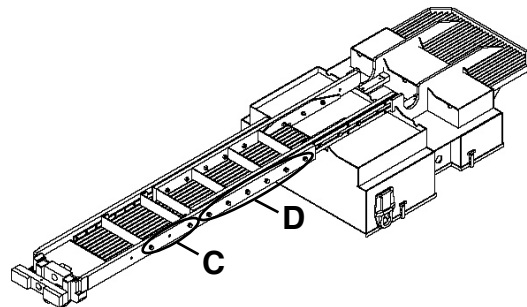

*Extended Haul Unit - Bottom View*

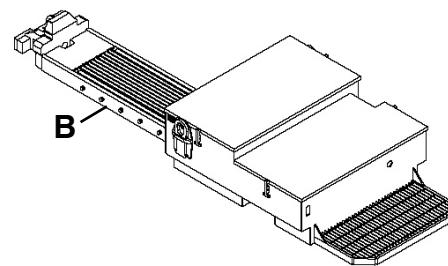

*Standard Haul Unit - Top View*

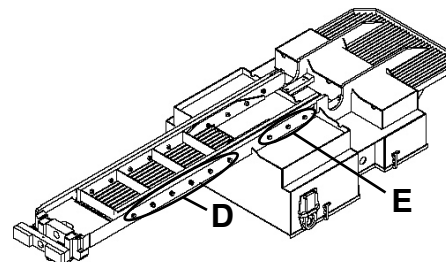

*Standard Haul Unit - Bottom View*

## RECHARGING THE BATTERY PACK

**⚠ WARNING** Batteries produce explosive gases. Wear eye protection and protective clothing during battery service. Keep sparks, flames, and cigarettes away from batteries.

If acid enters eye, IMMEDIATELY flush eye with running cold water for at least 15 minutes and get medical attention.

If battery acid contacts skin or clothing, wash immediately with soap and water.

Do not expose charger to rain or snow. Charge batteries only in a well ventilated area away from open flames and sparks.

The battery charger is a self-regulating charger. When the battery has reached its maximum state of charge, the circuitry will automatically turn the charger off.

The batteries can be recharged while the battery pack is in the haul unit or at the spare battery pack.

### RECHARGING AT HAUL UNIT

1. Slide charger plate (A) UP.
2. Connect the charger DC output plug to charger plug on haul unit.
3. Before recharging battery, remove battery compartment cover to assure proper ventilation.
4. Check battery electrolyte level. Follow instructions from battery manufacturer.
5. Connect AC supply cord to a properly grounded single phase outlet of the proper voltage and frequency as specified on front of charger.
6. The charger will start after a short delay as indicated by the transformer hum and the ammeter movement (B).
7. After properly charged, ALWAYS disconnect AC cord from its outlet first.
8. Secure battery compartment cover and disconnect DC output plug from charger plug.
9. Slide charger plate DOWN so the charger plug is fully covered.
10. Store battery charger in a clean, dry area.

(continued on next page)

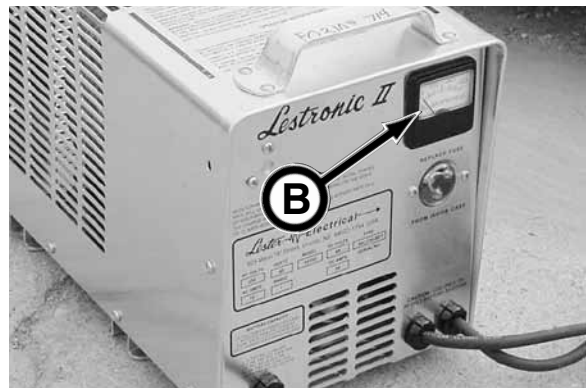
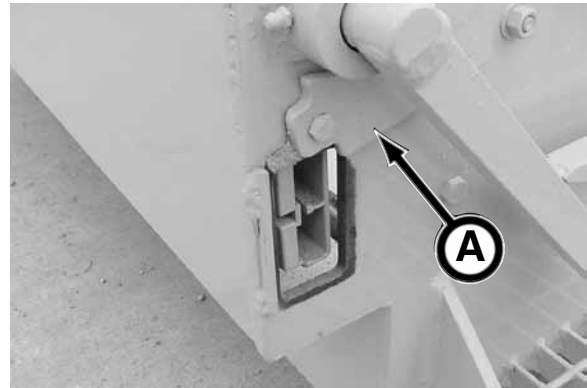
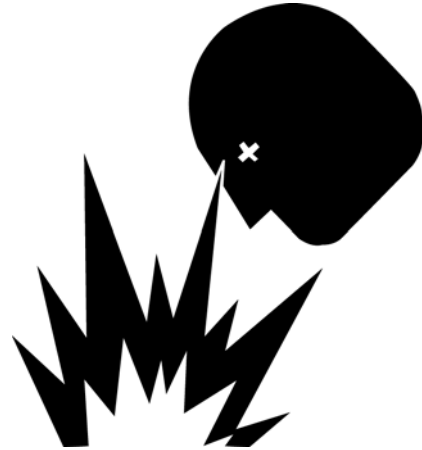

**RECHARGING SPARE BATTERY PACK**

1. Check battery electrolyte level. Follow instructions from battery manufacturer.
2. Connect the charger DC output plug to battery harness plug.
3. Connect AC supply cord to a properly grounded single phase outlet of the proper voltage and frequency as specified on front of charger.



4. The charger will start after a short delay as indicated by the transformer hum and the ammeter movement (A).

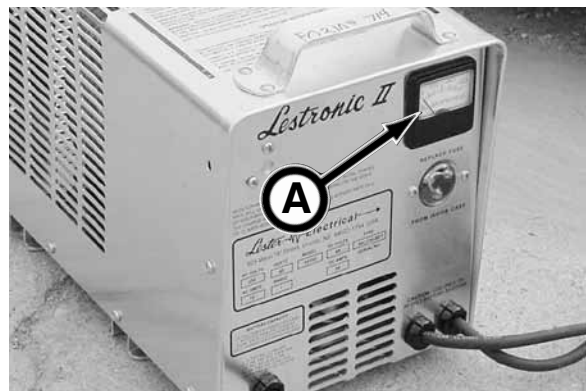

5. After properly charged, ALWAYS disconnect AC cord from the outlet first.
6. Disconnect DC output plug from battery harness plug.
7. Store battery charger in a clean, dry area.



For more information, refer to your Battery Charger Operation Manual.

*Operation*

## **NOTES**

# Transporting

---

## TRANSPORTING GUIDELINES

1. Know the local, state, and federal transportation regulations.
2. Obtain required permits for transporting.
3. Remove any obstacles from the trailer floor.
4. Load and unload on level ground.
5. It is best to lower haul unit onto blocks on trailer floor. This will make it easier when using fork lift to remove haul unit from trailer.
6. Do not use chain to fasten haul unit to trailer floor. Use straps to prevent damage to haul unit.
7. Lower spare battery pack into dirt bucket for transporting.
8. Be careful if using chains to secure dirt bucket. Travel vibration can cause chain hammering. If possible, use straps to secure dirt bucket to trailer floor.

**NOTES**

# Lubricants

## NOTICE

Use of inferior lubricants can affect the efficient performance of your Haul Unit. Always use high quality lubricants as specified in this section. Refer to the Periodic Maintenance section for proper lubrication quantity, maintenance intervals, and procedures.

## GEAR BOX LUBRICANT

The gear box (A) is filled with Mobil SHC 630 Synthetic Bearing and Gear Oil.

Use Mobil SHC 630 or equivalent when adding or changing lubricant.

## NOTICE

The Mobil SHC 630 Synthetic Bearing and Gear oil is a synthetic oil specifically designed for this application. If you change to a different oil, use a reputable oil supplier to meet or exceed the Mobil SHC 630 oil specification. Do not mix oil manufacturers or grades.

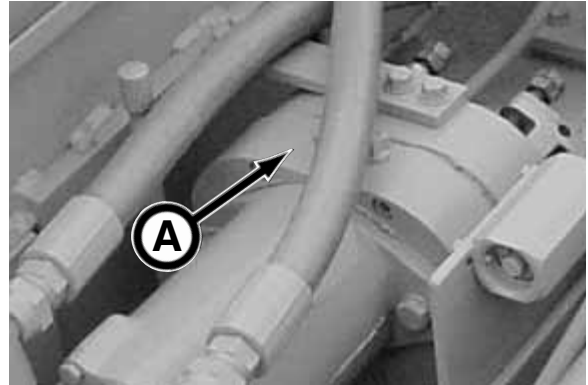

## HYDRAULIC RESERVOIR LUBRICANT

The hydraulic reservoir is filled with ISO-VG-46-20W Premium Hydraulic/Turbine Oil.

Use an API GL-1/GL-2 or equivalent when adding or changing lubricant. Replace fill cap (B).

## NOTICE

If you change to a different oil, use a reputable oil supplier to meet or exceed the ISO-VG-46-20W or API GL-1/GL-2 oil specification. Do not mix oil manufacturers or grades.

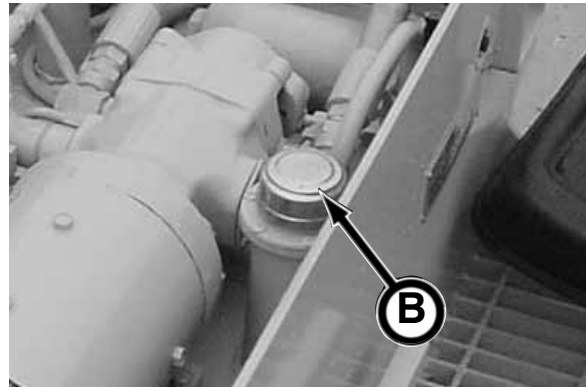

## BRAKE FLUID

The master cylinder (C) is filled with a DOT 3 brake fluid.

Use ONLY a DOT 3 brake fluid when adding or changing fluid.

## NOTICE

Never mix different manufacturer's brake fluids since the fluids may be incompatible resulting in brake failure.

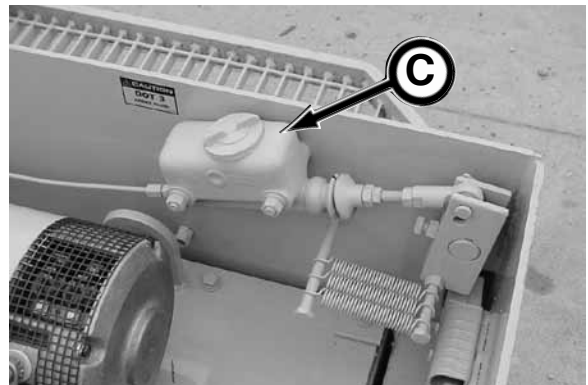

---

## GREASE

The lubrication fittings are greased with Mobilgrease® XHP222 Premium Lubricating Grease.

The XHP222 grease is a multipurpose, high performance, high temperature, lithium grease.

Use Mobilgrease® XHP222 Premium Lubricating Grease or equivalent when lubricating the lubrication points.

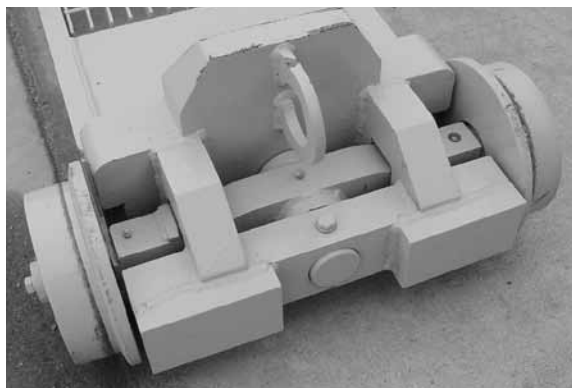

---

## STORING LUBRICANTS

Your equipment can operate at maximum performance only if clean lubricants are used. Use clean containers to handle all lubricants.

Lubricants should be stored in an area protected from dust, moisture, and other contaminants.



# Periodic Maintenance

**⚠ WARNING** Review the Safety section in this manual before performing maintenance. Failure to do so, could cause severe injury or death.

The requirements for lubrication and maintenance are shown on the maintenance charts in this section. Intervals of maintenance are based on normal operating conditions. If operating under more difficult conditions, use a shorter time interval between maintenance.

---

## LOCKOUT POWER BEFORE SERVICING

**⚠ WARNING** Severe personal injury or death can result from unexpected haul unit startup or machine movement.

LOCKOUT power before attempting to make repairs or adjustments to this equipment, unless otherwise indicated. Proper lockout will prevent accidents and save lives. Performing the lockout will also prevent the equipment from moving unexpectedly.

1. Disconnect battery pack connector from harness connector.



2. Remove battery pack from the haul unit to prevent unintentional connecting of power.

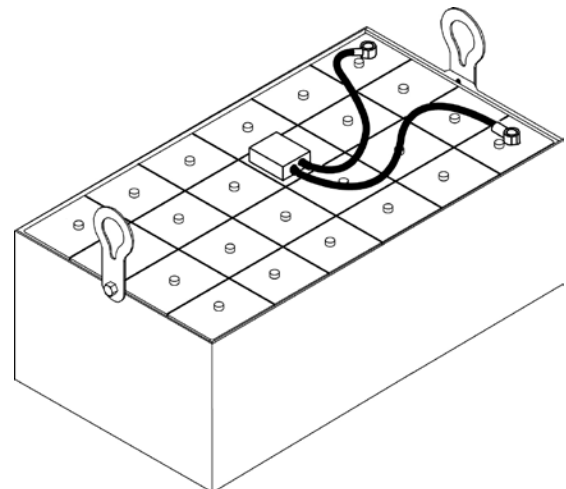

## MAINTENANCE CHARTS

Use the item number in the chart to refer to the detailed maintenance procedures later in this section.

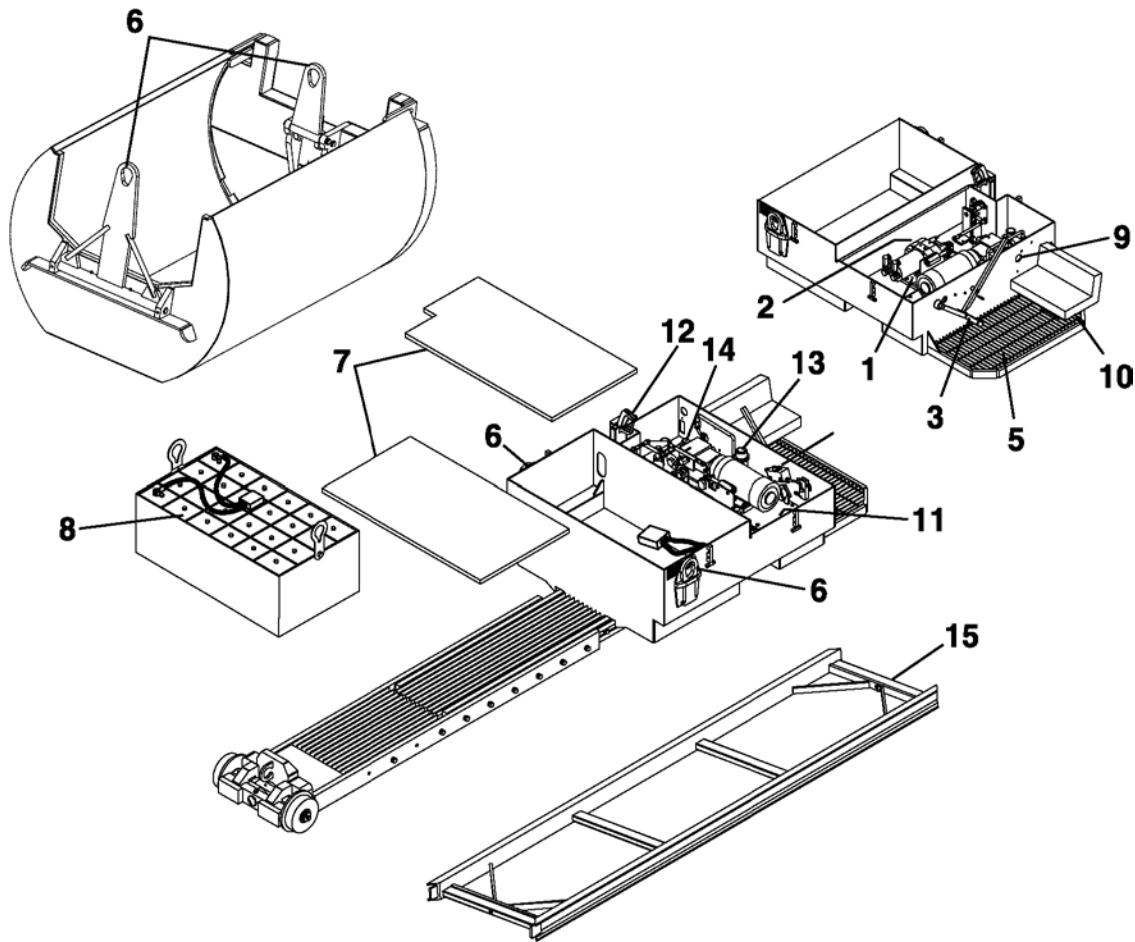

### DAILY OR EVERY 10 HOURS OF OPERATION OR SHIFT CHANGE

ITEM	COMPONENT	SERVICE	REQUIREMENT	MATERIAL
1.	Gear Box	Inspect for Leaks		
2.	Gear Box	Check Oil Level	Fill to full mark on dipstick.	Mobil SHC 630
3.	Brakes	Test Operation		
4.	Brake Fluid	Check Fluid Level	Refill master cylinder as needed.	DOT 3 Brk. Fluid
5.	Operator Platform	Clean and Inspect	If damaged, repair or replace.	
6.	Lifting Eyes	Inspect Pins and Hardware	If damaged, repair or replace.	
7.	Covers	Inspect	If damaged, repair or replace.	
8.	Battery	Clean and Inspect		
9.	Battery Charge	Test	Recharge or replace if needed.	
10.	Seat	Check Seat Mounting	If damaged, replace immediately.	
11.	Contactors	Clean	Remove dirt and moisture.	Contact Cleaner
12.	Controller	Clean and Test		
13.	Hydraulic Reservoir	Check Oil Level	Refill as needed.	ISO-VG-46-20W
14.	Hydraulic Filter	Check Indicator	Replace filter per indicator.	
15.	Track	Inspect	If damaged, repair or replace.	

Use the item number in the chart to refer to the detailed maintenance procedures later in this section.

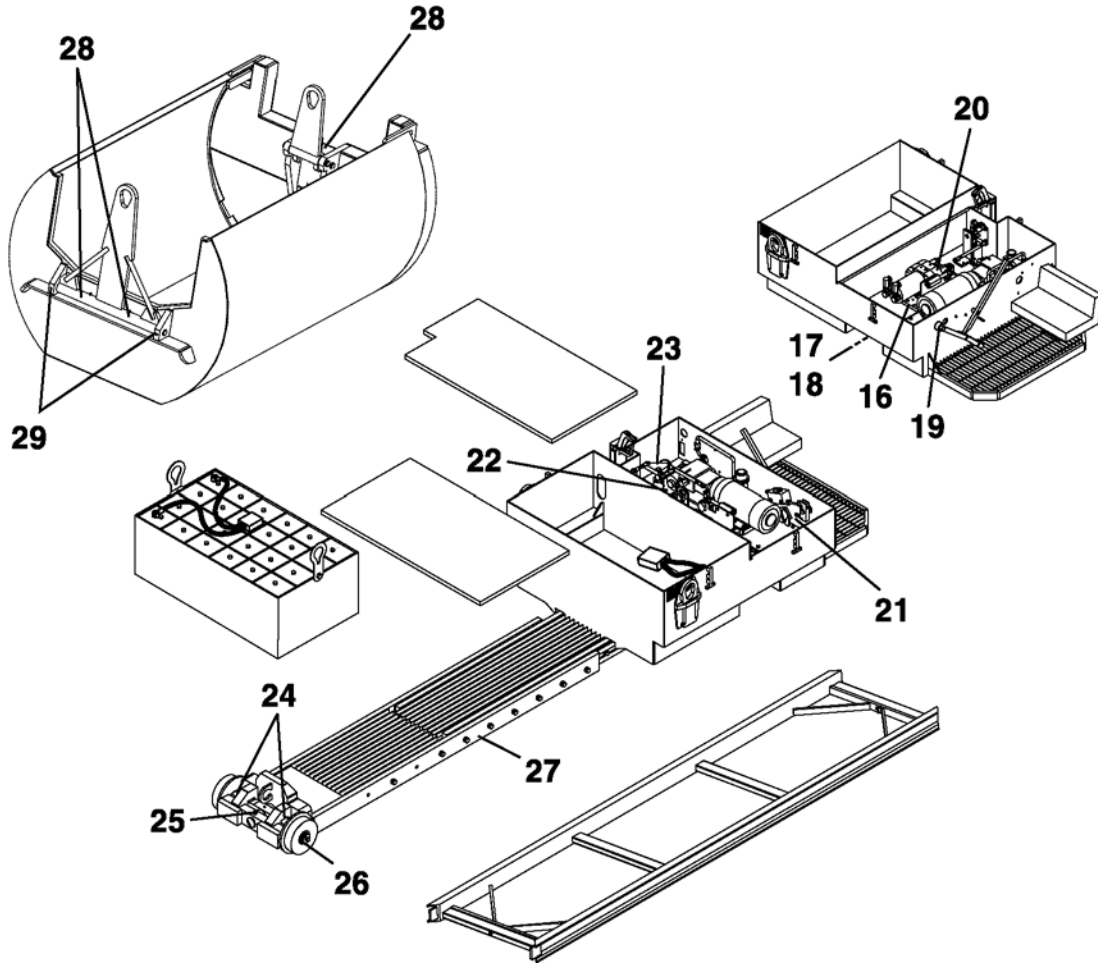

**WEEKLY OR EVERY 50 HOURS OF OPERATION**

ITEM	COMPONENT	SERVICE	REQUIREMENT	MATERIAL
16.	Gear Box	Check Mounting Bolts	Tighten to 170 ft-lb. (231 N-m).	Torque Wrench
17.	Gear Box	Check Wheels & Bearings		
18.	Axle Pillow Block Bearings	Lubricate	*Lubricate with 2 shots of grease.	Mobil XHP222
19.	Brake Lever	Lubricate	Lubricate until grease is forced out.	Mobil XHP222
20.	Brake	Inspect	Repair or replace as needed.	
21.	Brake Linkage	Lubricate	Spray	Silicone Lubricant
22.	Hoses	Inspect	If worn or damaged, replace with new.	
23.	Pivot Linkage	Lubricate	Lubricate until grease is forced out.	
24.	Idler Assembly	Lubricate Wheel Bearings	Lubricate until grease is forced out.	Mobil XHP222
25.	Axle Pivot Pin	Lubricate	Lubricate until grease is forced out.	Mobil XHP222
26.	Idler Assembly	Inspect Wheels & Bearings	If damaged, replace with new.	
27.	Frame Rails	Inspect	If damaged, contact factory.	
28.	Lift Eye/Bar Hinge	Lubricate (3 places)	Lubricate until grease is forced out.	Mobil XHP222
29.	Lift Eye/Bar Hinge	Check set screw (4 places)	Tighten.	

\* Lubricate bearings daily if subjected to water or mud.

Periodic Maintenance Chart - Monthly or Every 250 Hours of Operation

Use the item number in the chart to refer to the detailed maintenance procedures later in this section.

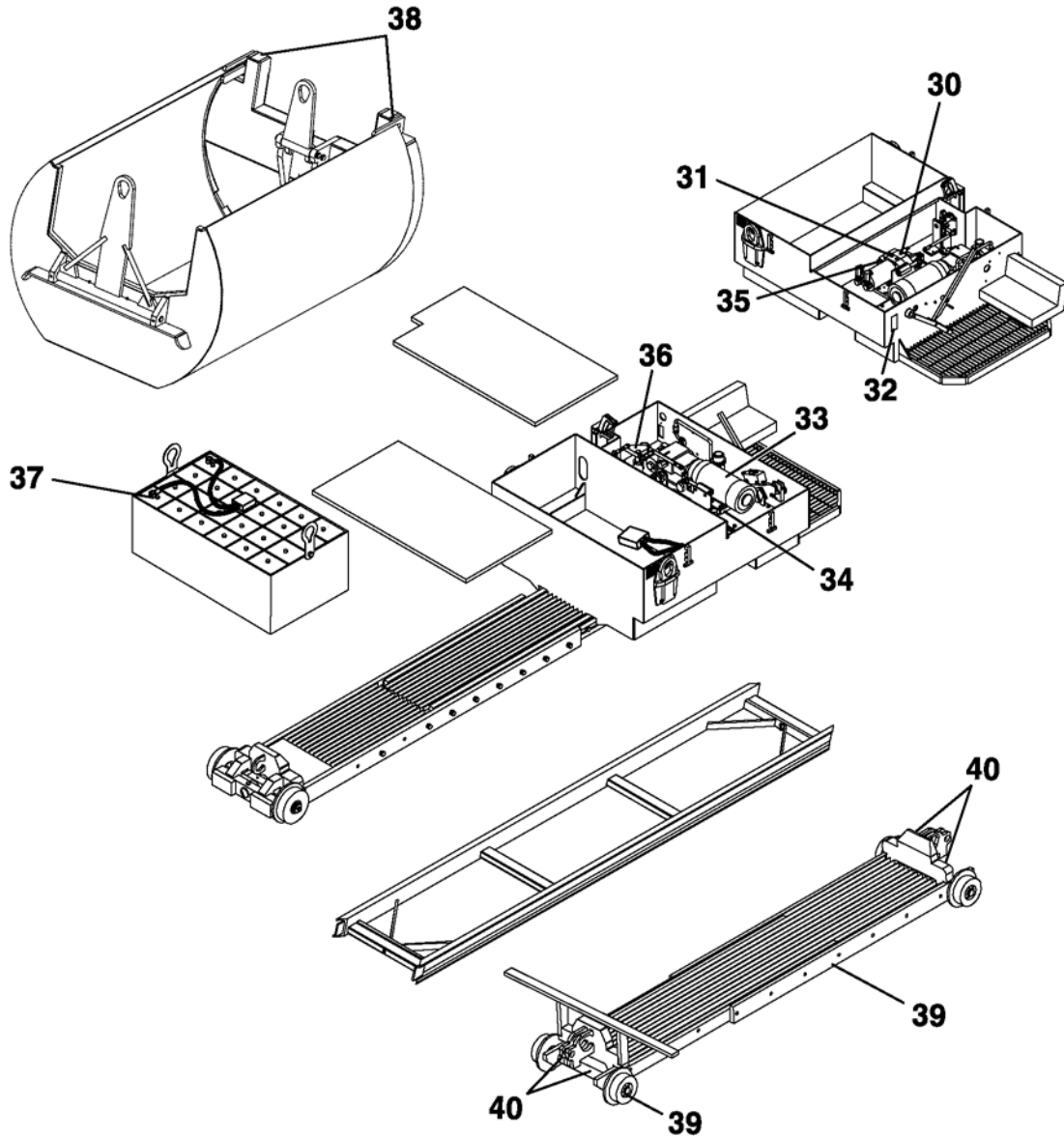

**MONTHLY OR EVERY 250 HOURS OF OPERATION**

ITEM	COMPONENT	SERVICE	REQUIREMENT	MATERIAL
30.	Gear Box	Drain and Fill Check Magnetic Plug	1 pt. (0.47L) Check for metal particles. If damaged, replace with new.	Mobil SHC 630
31.	Gear Box Relief	Inspect		
32.	Charging Plug	Clean		
33.	Motor, Electric	Inspect and Clean Brushes		Contact Cleaner
34.	Motor, Electric	Check Mounting Bolts	Base Mount - 20 ft-lb (27 N·m) To Pump Mount - 35 ft-lb (47 N·m)	Torque Wrench
35.	Hydraulic Motor	Check Mounting Bolts	Tighten to 85 ft-lb (115 N·m)	Torque Wrench
36.	Throttle Control Linkage	Lubricate Bearing Shaft & Tower Assembly		
37.	Batteries	Inspect and Clean		Baking Soda
38.	Bucket Door Pivot	Inspect	Solution If damaged, replace with new.	
39.	Haul Cart	Inspect Frame & Wheel Bearings	If damaged, repair or replace.	
40.	Haul Cart Wheels	Lubricate Wheel Bearings	Lubricate until grease is forced out.	Mobil XHP222

*Periodic Maintenance Chart - Every 500 Hours Or When Engulfed With Water*

Use the item number in the chart to refer to the detailed maintenance procedures later in this section.

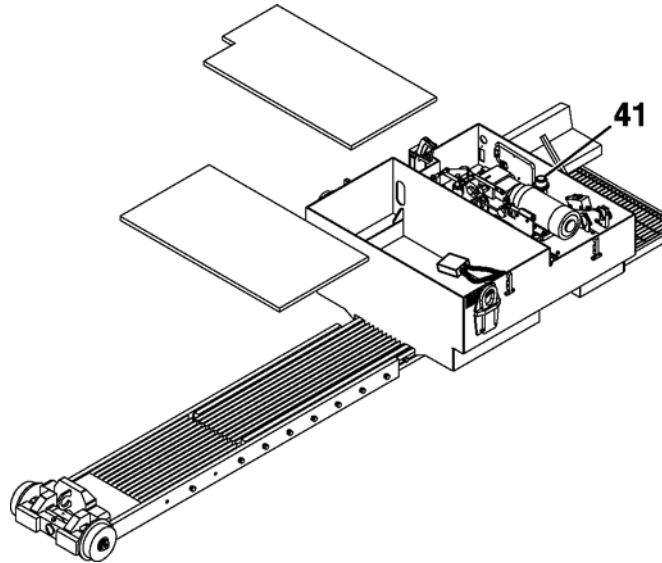

**EVERY 500 HOURS OR WHEN ENGULFED WITH WATER**

<b>ITEM</b>	<b>COMPONENT</b>	<b>SERVICE</b>	<b>REQUIREMENT</b>	<b>MATERIAL</b>
41.	Hydraulic Reservoir	Drain & Fill	Oil Level - 10 gallons (37.8 L)	ISO-VG-46-20W

## DAILY OR EVERY 10 HOURS OF OPERATION OR SHIFT CHANGE

### 1. INSPECT GEAR BOX

1. Remove drive box cover to gain access to gear box (A).
2. Visually check gear box for leaks. If any leaks are present, determine the cause and repair gear box before operating haul unit.
3. If necessary, add oil. See “2. Check Gear Box Oil Level” in this section for proper oil type and refilling procedure.
4. Secure drive box cover.

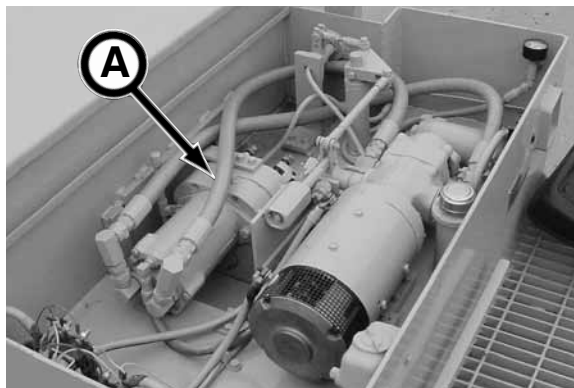

### 2. CHECK GEAR BOX FLUID LEVEL

1. With haul unit on level ground, open drive box cover to gain access to the gear box. Clean area around dipstick (B) and fill plug (C).
2. Remove dipstick. Wipe the dipstick with a clean, lint free cloth. Reinstall the dipstick and remove dipstick to check oil level.
3. If fluid is not at top notch (full mark) on dipstick, remove fill plug and add Mobil SHC 630 or equivalent until oil is at the top notch. **DO NOT OVERFILL.**

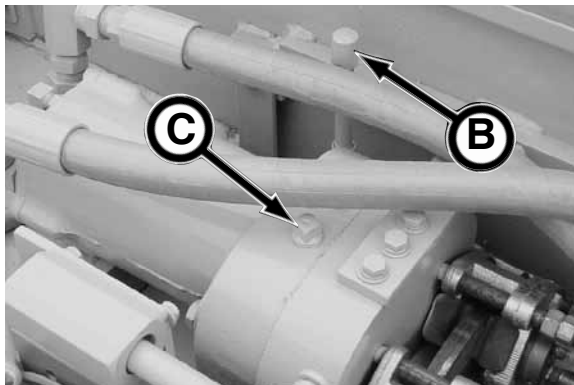

#### NOTICE

The Mobil SHC 630 Synthetic Bearing and Gear oil is a synthetic oil specifically designed for this application. If you change to a different oil, use a reputable oil supplier to meet or exceed the Mobil SHC 630 oil specification. Do not mix oil manufacturers or grades.

4. Replace dipstick and fill plug. Secure drive box cover.

### 3. TEST BRAKE OPERATION

Before operating haul unit, test the brake operation by depressing brake pedal.

If the haul unit fails to brake properly, repair the brake system before operating in the pipeline.



#### 4. CHECK MASTER CYLINDER BRAKE FLUID LEVEL

1. With the haul unit on a level surface, remove drive box cover to gain access to the master cylinder reservoir (A).
2. Clean area around the master cylinder reservoir.
3. Remove filler cap (B) on master cylinder reservoir. The brake fluid should be 1/8 in. to 1/4 in. from the bottom of the fill neck.

If needed, fill reservoir ONLY with new brake fluid that meets or exceeds DOT 3 specifications.

4. Replace filler cap.

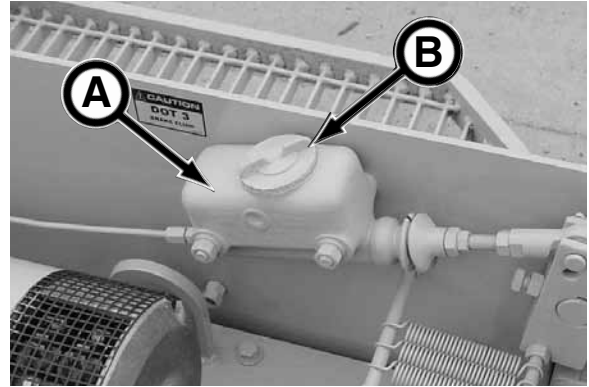

#### 5. INSPECT OPERATOR PLATFORM

Clean and inspect operator platform (C) for cracks or other damage.

If cracks or damage are present, contact your Akkerman Product Support representative for authorized repair or replacement procedures.

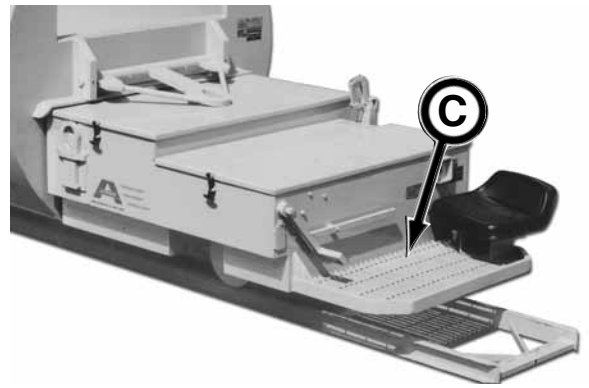

#### 6. INSPECT HAUL UNIT, DIRT BUCKET & BATTERY PACK LIFTING EYES, PINS & HARDWARE

##### HAUL UNIT

Inspect haul unit lifting eyes (D) for cracks or other damage. Repair or replace before lifting.

Check hardware for damage. If damaged, replace with new.

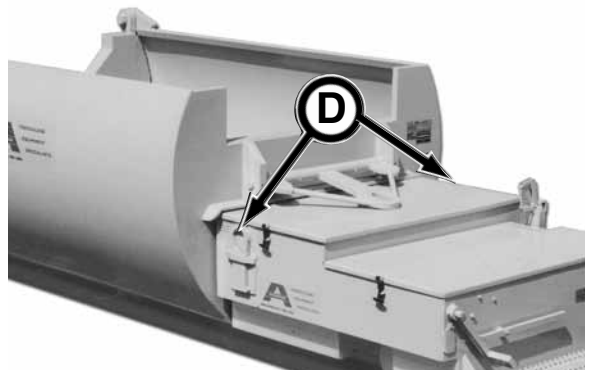

*Haul Unit Lifting Eyes*

##### DIRT BUCKET

Inspect dirt bucket lifting eyes (E) for cracks or other damage. Repair or replace before lifting.

Check pins and hardware (F) for damage. If damaged, replace with new.

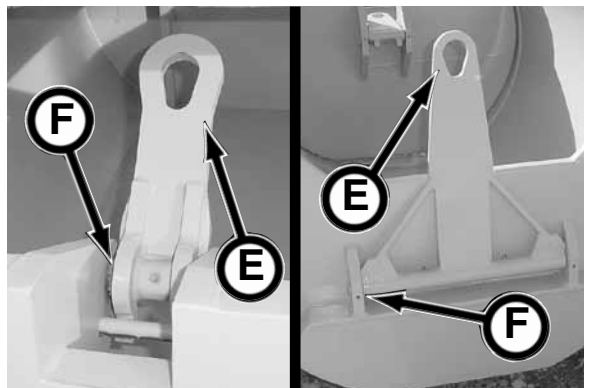

*Dirt Bucket Lifting Eyes*

### 7. INSPECT COMPARTMENT COVERS

Clean and inspect battery compartment cover (A) and drive box cover (B) for cracks or other damage. Repair or replace as required.

Check to make sure the rubber cover fasteners will securely hold cover to haul unit. If not, replace as required.

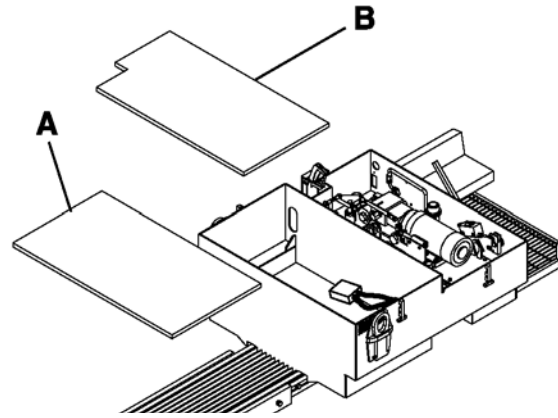

### 8. CLEAN & INSPECT BATTERY

Keep top of batteries clean.

Inspect battery for damage or leakage. Replace as needed.

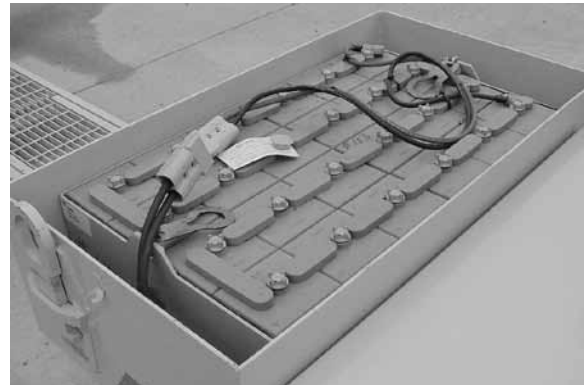

### 9. TEST BATTERY CHARGE

Depress the battery charge button (C) and check the battery charge level on gauge (D). If the indicator needle is in the red zone, recharge the battery.

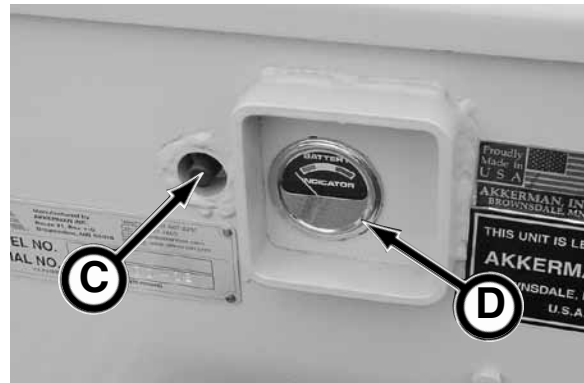

### 10. CHECK SEAT MOUNTING

Before each use, check seat mounting. Tighten loose hardware.

If cracks or rust occur, replace seat and mounting hardware immediately.



## 11. CLEAN CONTACTORS

Clean contactors (A) with an approved contact cleaner to remove dirt and moisture.

**⚠ WARNING** Contact cleaner is EXTREMELY FLAMMABLE.

Replace contacts if they become sticky or pitted.

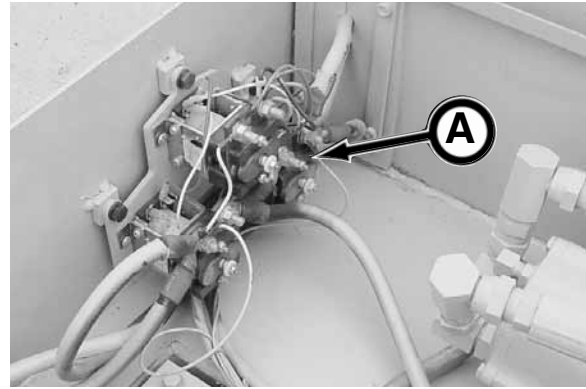

## 12. INSPECT CONTROLLER

1. Clean and inspect the controller (B) for damage.

2. Test the controller functions for proper operation.

**NOTICE** The battery pack must be connected to perform this test.

Discontinue use if operating mechanism becomes sticky or switches are inoperable. Repair or replace controller components immediately.

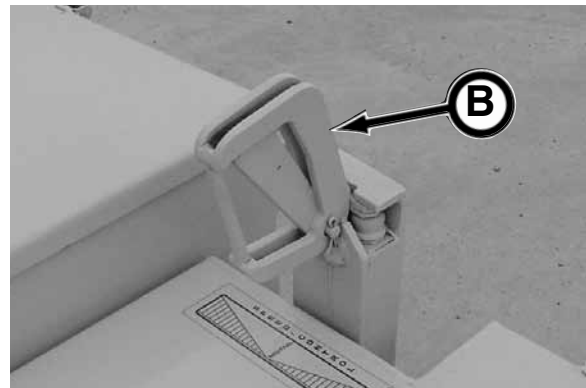

## 13. CHECK HYDRAULIC RESERVOIR OIL LEVEL

1. Clean area around reservoir filler cap (C).

2. Remove filler cap to check if oil level is at the bottom of the filler neck.

If needed, fill reservoir with fresh, ISO-VG-46-20W Premium Hydraulic/Turbine Oil or equivalent. See Lubricants section for proper lubricant.

3. Replace filler cap.

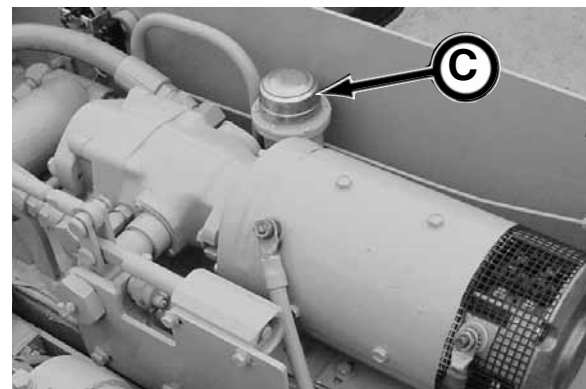

#### 14. CHECK HYDRAULIC FILTER

Check the hydraulic filter indicator (A). If the needle is in the red (CHANGE) zone, change the filter (B) immediately.

1. Remove barrel housing (C) from cap (D) by using a wrench on the hex (E) at the bottom of the housing.
2. The spring (F) in the barrel will push filter element upward for easy removal.
3. Remove and discard old o-ring (G) and filter element (H).
4. Install new o-ring into cap.
5. Install new filter element into housing.
6. Tighten barrel housing onto cap.

**A - Hydraulic Filter Indicator**  
**B - Filter**  
**C - Filter Barrel Housing**  
**D - Cap**

**E - Hex**  
**F - Spring**  
**G - O-ring**  
**H - Filter Element**

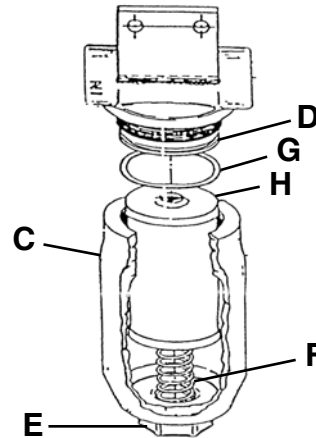
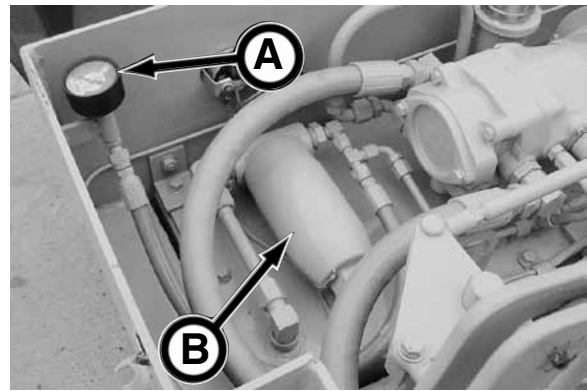

#### 15. INSPECT TRACK

Check to be sure each track section is securely fastened.

Inspect track for cracks or other damage. Repair or replace as required.



## WEEKLY OR EVERY 50 HOURS OF OPERATION

### 16. CHECK GEAR BOX MOUNTING HARDWARE TORQUE

Check four mounting bolts (A) for tightness. Tighten to 170 ft.lb. (231 N·m) torque.

If bolts are damaged or do not hold torque, replace with new bolts, flat washers, and lock washers.

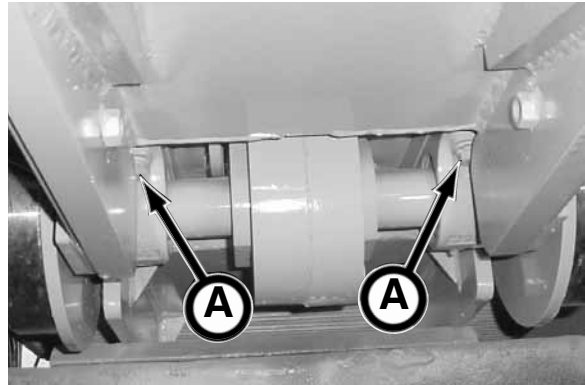

### 17. CHECK GEAR BOX WHEEL & BEARINGS

Check bearings (B) and wheels (C) for damage. If damaged, replace with new.

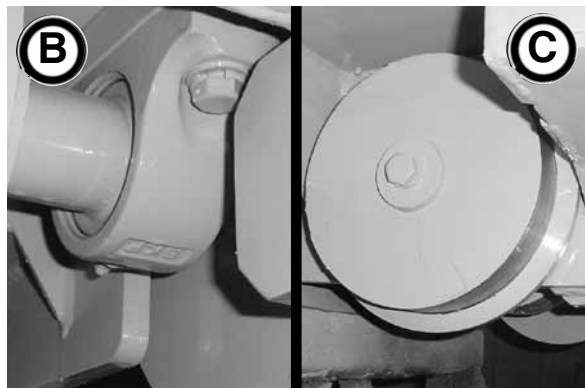

### 18. LUBRICATE AXLE PILLOW BLOCK BEARINGS

Lubricate the bearings (D) (2 places) with 2 shots of Mobilgrease® XHP222 or equivalent.

Lubricate daily if bearings are subjected to water and mud.

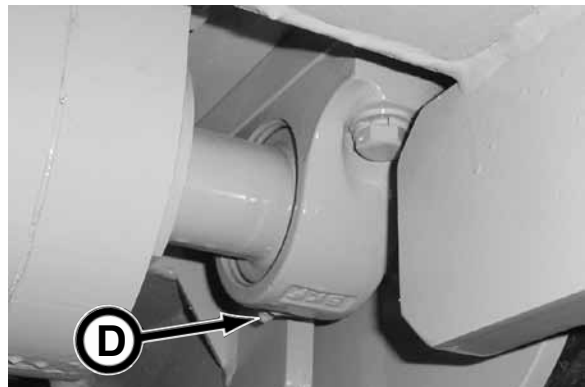

### 19. LUBRICATE BRAKE LEVER

Lubricate the brake lever (E) with Mobilgrease® XHP222 or equivalent until grease is forced out.

Lubricate brake lever daily if it is subjected to water and mud.

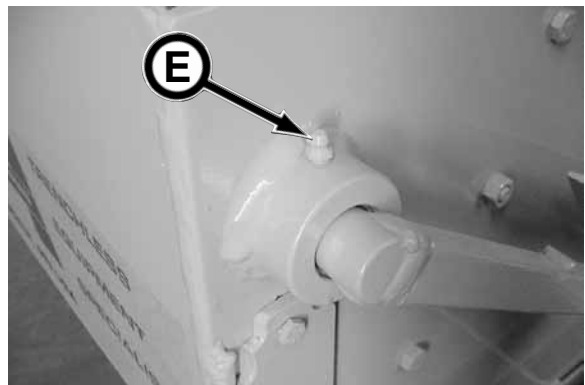

## 20. INSPECT BRAKE

Inspect brake for any of the following conditions:

- build up on brake rotor
- leaking brake fluid
- build up of foreign matter in brake area
- spongy brake
- brake linkage binding
- damaged brake line
- any other unusual conditions

If any of these conditions occur, have your brake repaired IMMEDIATELY by a qualified brake technician.

**⚠ WARNING** If any of these conditions exist, do not operate haul unit until the brake has been repaired. Failure to do so could cause severe injury or death.



## 21. LUBRICATE BRAKE LINKAGE

Lubricate the brake linkage with an aerosol silicone lubricant.

**⚠ WARNING** DO NOT ALLOW ANY SPRAY LUBRICANT OR SPRAY VAPOR TO TOUCH THE BRAKE ASSEMBLY. DOING SO COULD CAUSE THE BRAKE TO MALFUNCTION AND CAUSE SERIOUS PERSONAL INJURY OR DEATH.

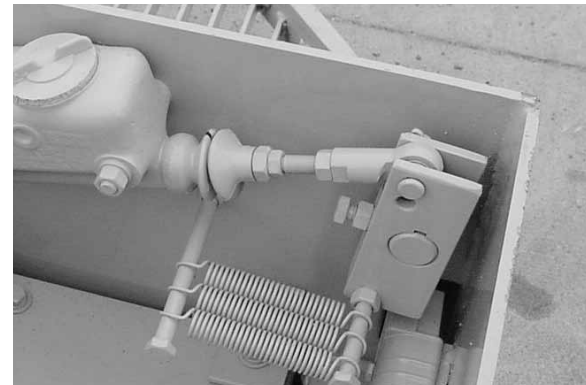

## 22. INSPECT ALL HOSES

Inspect all hoses for wear or damage. Do not operate the haul unit until the worn or damaged hoses are replaced.

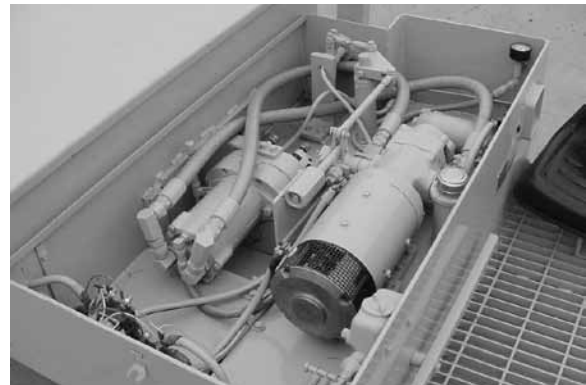

### 23. LUBRICATE PIVOT LINKAGE

Lubricate the pivot linkage (indicated with white boxes in photo) with an aerosol silicone lubricant.

**⚠ WARNING** DO NOT ALLOW ANY SPRAY LUBRICANT OR SPRAY VAPOR TO TOUCH THE BRAKE ASSEMBLY. DOING SO COULD CAUSE THE BRAKE TO MALFUNCTION AND CAUSE SERIOUS PERSONAL INJURY OR DEATH.

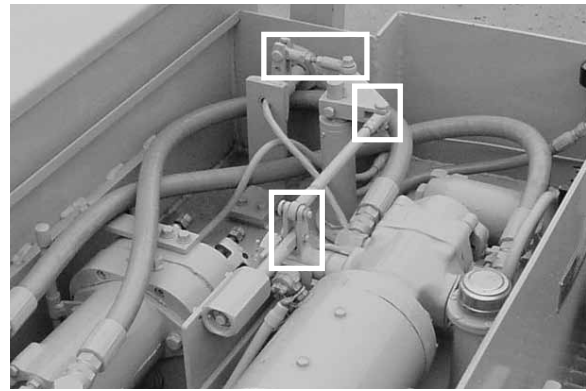

### 24. LUBRICATE IDLER WHEEL BEARINGS

Lubricate the bearings (A) with Mobilgrease® XHP222 or equivalent until grease is forced out.

Lubricate more often in wet or muddy conditions.

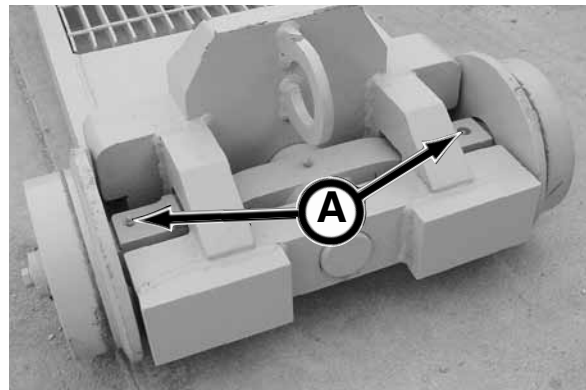

### 25. LUBRICATE IDLER AXLE PIVOT PIN

Lubricate the pivot pin (B) with Mobilgrease® XHP222 or equivalent until grease is forced out.

Lubricate more often in wet or muddy conditions.

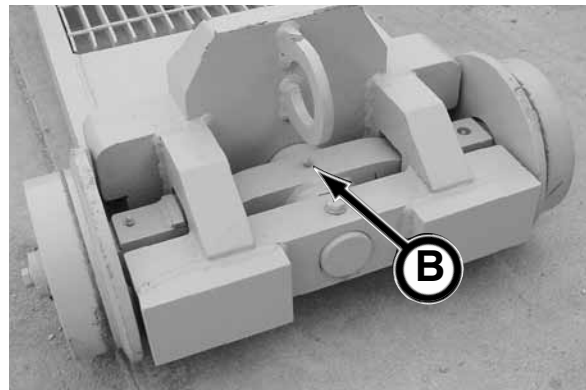

### 26. INSPECT IDLER ASSEMBLY WHEELS & BEARINGS

Inspect idler wheels and bearings for damage. If damaged, replace with new.



### 27. INSPECT HAUL UNIT FRAME RAILS

Inspect frame rails (A) for cracks.

Contact your Akkerman Product Support representative if cracks are present.

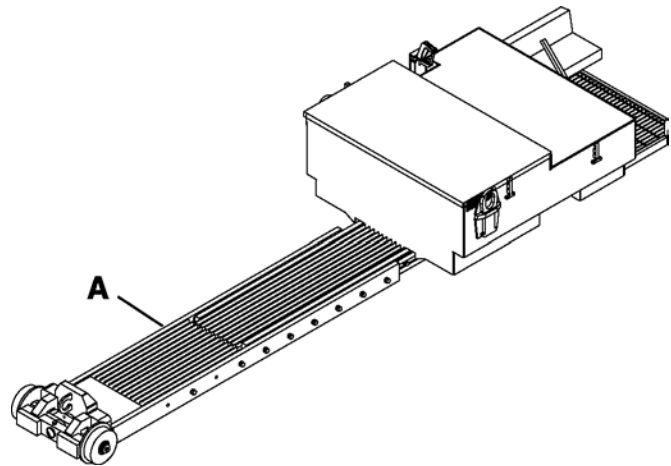

### 28. LUBRICATE DIRT BUCKET LIFTING EYE & LIFTING EYE BAR HINGE

Lubricate lifting eyes (B) with Mobilgrease® XHP222 or equivalent until grease is forced out.

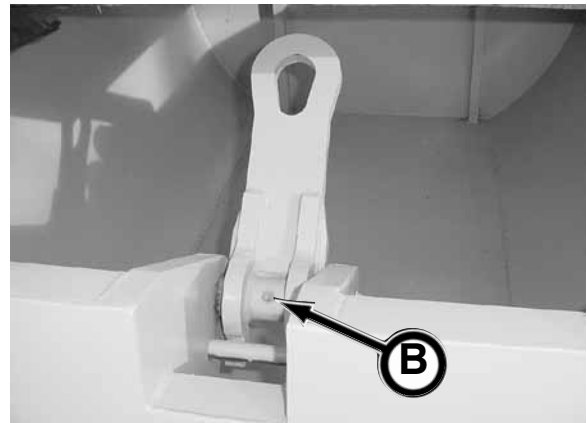

Lubricate lifting eye bar hinge (C) with Mobilgrease® XHP222 or equivalent until grease is forced out.

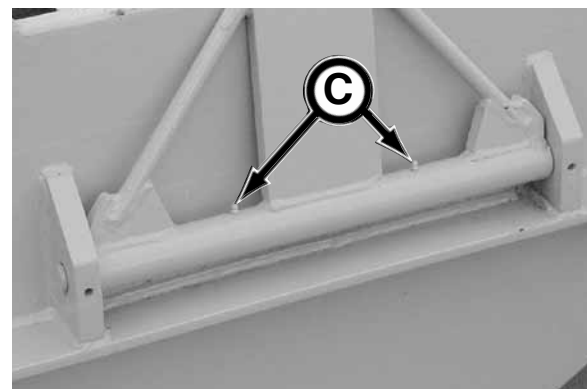

**29. CHECK DIRT BUCKET LIFTING EYE & LIFT BAR HINGE PIN SET SCREWS**

Tighten set screws (A) on lifting eye and set screws (B) on lift bar hinge pin if loose.

If set screws are damaged or will not hold, replace with new.

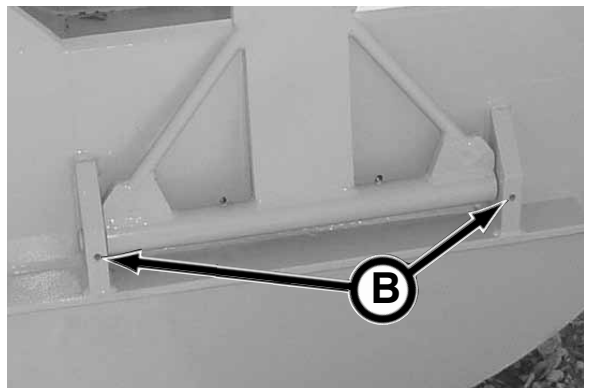
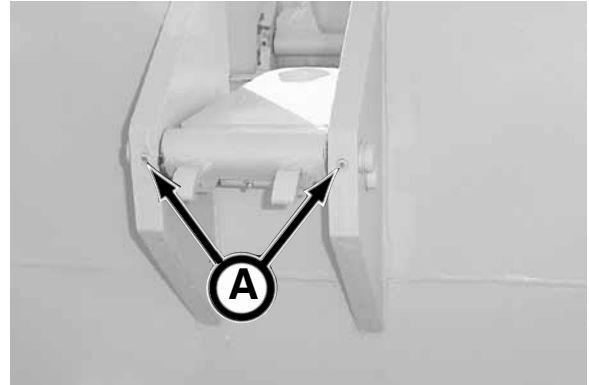

## MONTHLY OR EVERY 250 HOURS OF OPERATION

### 30. DRAIN & FILL GEAR BOX

1. With haul unit on level ground, clean area around fill and drain plugs.
2. Remove drain plug (A) and empty fluid into a proper sized catch pan. Dispose of fluid properly.
3. Inspect drain plug for metal particles. If particles are present, contact your Akkerman Product Support representative for gear box preventive maintenance procedures.
4. Clean drain plug.
5. Replace drain plug. If fluid leakage was present before draining gear box, or if leakage exists after filling gear box, replace drain plug sealing washer.
6. Remove fill plug (B) and add Mobil SHC 630 Synthetic Bearing and Gear Oil or equivalent.

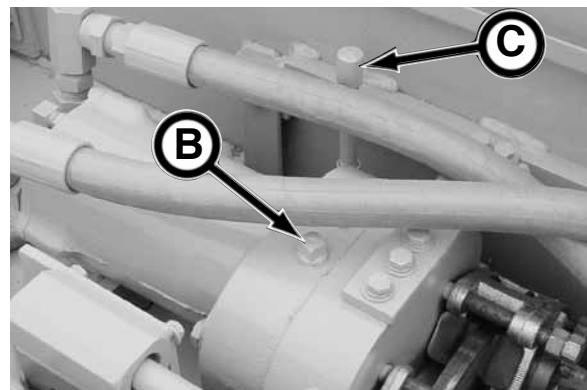
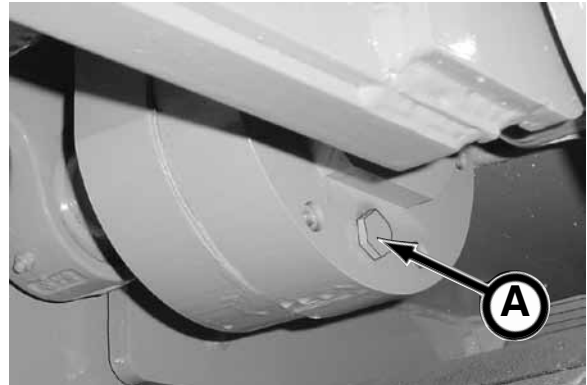

#### NOTICE

The Mobil SHC 630 Synthetic Bearing and Gear oil is a synthetic oil specifically designed for this application. If you change to a different oil, use a reputable oil supplier to meet or exceed the Mobil SHC 630 oil specification. Do not mix oil manufacturers or grades.

The fluid should be level with notch on dip stick (C).

7. Place a small amount of pipe sealant on plug threads.
8. Replace check and fill plugs.

### 31. INSPECT GEAR BOX PRESSURE RELIEF

Inspect pressure relief fitting on the gear box to make sure the relief plug can open. If relief vent plug is stuck, or does not pop back into fitting, replace with new.

A malfunctioning pressure relief fitting could result in gear box seal failure.



### 32. CLEAN CHARGING PLUG

Clean charging plug (A) with an approved contact cleaner.

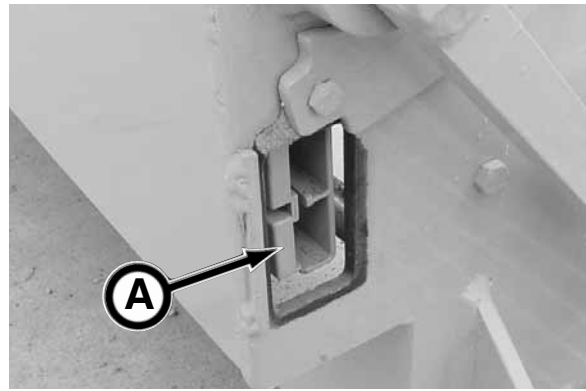

### 33. INSPECT & CLEAN MOTOR BRUSHES

Remove electric motor cover (B) to inspect brushes. If worn or damaged, replace with new.

Clean brushes with contact cleaner.

Reinstall covers before using haul unit.

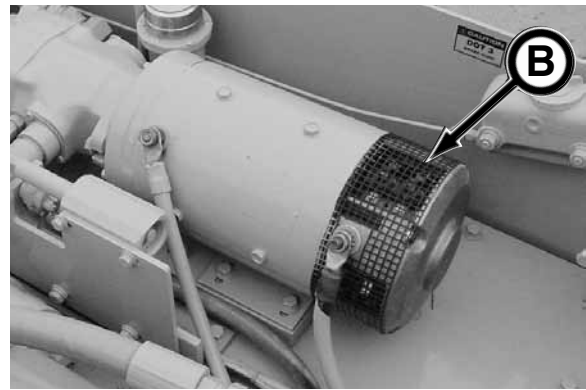

### 34. CHECK ELECTRIC MOTOR MOUNTINGS

#### BASE MOUNT

Check four motor mounting bolts (C). Retighten to 20 ft-lb. (27 N-m) torque.

If bolts are damaged or will not hold torque, replace with new.

#### MOTOR TO PUMP MOUNT

Check two mounting bolts (D). Retighten to 35 ft. lb. (47 N-m) torque.

If bolts are damaged or will not hold torque, replace with new.

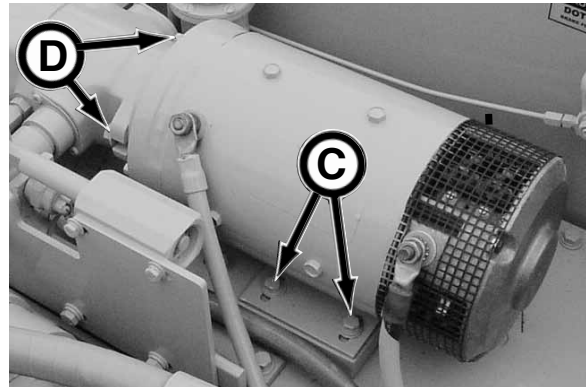

### 35. CHECK HYDRAULIC MOTOR MOUNTING

Check four motor mounting bolts (E). Retighten to 85 ft-lb. (115 N-m) torque.

If bolts are damaged or will not hold torque, replace with new.

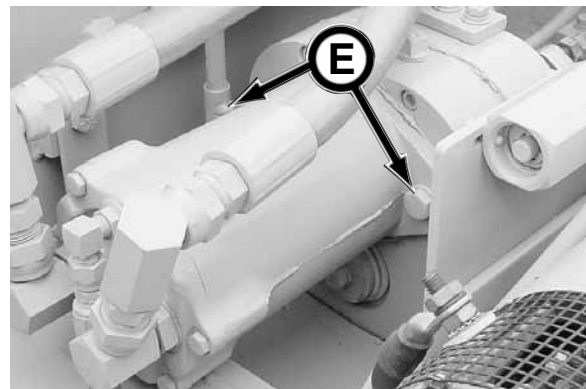

**36. LUBRICATE THROTTLE CONTROL LINKAGE**

Lubricate the throttle control linkage (A) with 2 shots of Mobilgrease® XHP222 or equivalent.

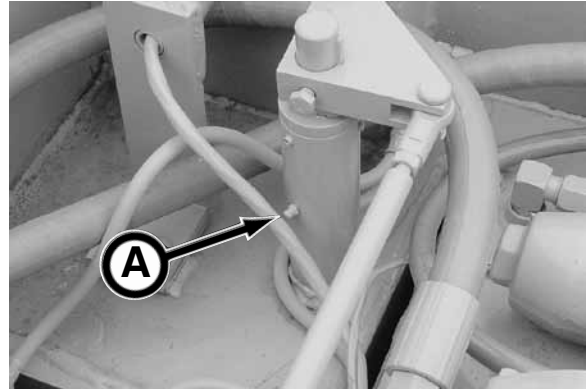

### 37. PERFORM BATTERY MAINTENANCE

**⚠WARNING** Batteries produce explosive gases. Wear eye protection and protective clothing during battery service. Keep sparks, flames, and cigarettes away from batteries. Charge batteries only in a well ventilated area.

If acid enters eye, IMMEDIATELY flush eye with running cold water for at least 15 minutes and get medical attention.

If battery acid contacts skin or clothing, wash immediately with soap and water.

If battery acid is inhaled, move to fresh air immediately. If breathing is difficult, administer oxygen.

If battery acid is ingested, give large quantities of water. DO NOT induce vomiting. Get medical attention immediately.

**NOTICE** For more information on battery maintenance, contact the battery manufacturer.

1. Clean cable connections with a wire brush. Coat the terminals with petroleum jelly to prevent corrosion. Never paint the terminal posts.
2. Check electrolyte level. Fill each cell with clean, distilled water to the bottom of the filler neck.
3. Check terminals and connections. Clean or replace if damaged. Maintenance on the battery must be performed only by a qualified battery technician.
4. Check cables for worn or frayed insulation. Replace cable or bolts if worn or corroded. Battery cable maintenance must be performed only by a qualified battery technician.
5. Inspect the batteries for dirt or corrosion. Clean corrosion with baking soda (1/4 pound of baking soda added to a quart of water).
6. Inspect battery pack frame for cracks or damage. If damaged, repair or replace.
7. If necessary, charge the batteries. See Recharging the Battery Pack in the Operation section of this manual.

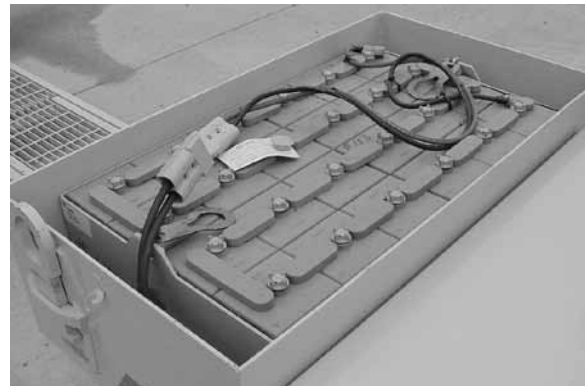

### 38. INSPECT DIRT BUCKET DOOR HARDWARE

Inspect door pivot hardware for damage. If damaged, repair or replace. Do not use until damaged hardware is repaired or replaced.



### 39. CHECK HAUL CART

Check the haul cart frame (A) for cracks or damage. If damaged, repair or replace.

Check the wheel bearings (B) and hardware for damage. If damaged replace with new.

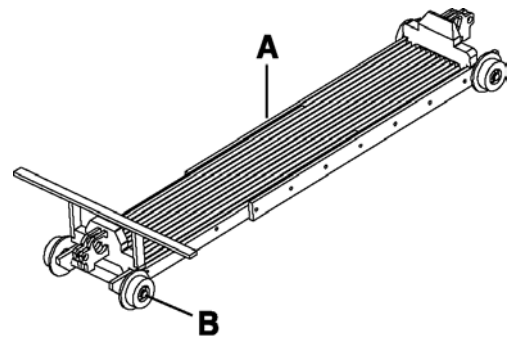

### 40. LUBRICATE HAUL CART WHEEL BEARINGS

Lubricate the bearings (C) with Mobilgrease® XHP222 or equivalent until grease is forced out.

Lubricate more often in wet or muddy conditions.

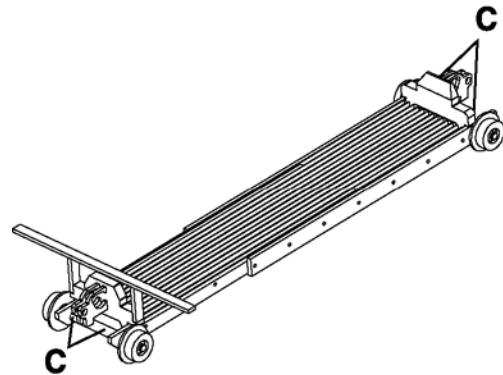

## EVERY 500 HOURS OR WHEN ENGULFED WITH WATER

### 41. DRAIN & FILL HYDRAULIC RESERVOIR

Drain and replace with new, fresh hydraulic oil into the reservoir every 500 hours or if any of the following situations occur:

- When haul unit is engulfed with water.
- A major component fails.
- Any sign of water contamination from an oil analysis or if oil is milky or foaming.
- A hydraulic oil sample indicates large particle contamination.

1. Drain reservoir (A) by using one of the following methods:

(a) suction the oil from the reservoir, or

(b) remove hoses and components from the reservoir cover (B), remove the cover, and discard the oil from the reservoir, replace cover, and reinstall hoses and components.

2. Replace the hydraulic filter. For proper replacement procedure, refer to "14. Check Hydraulic Filter" in this section.

3. Clean area around fill cap (C). Remove fill cap.

4. Fill reservoir with new, fresh ISO-VG-46-20W hydraulic oil or equivalent.

5. Replace cap.

6. Check for leaks.

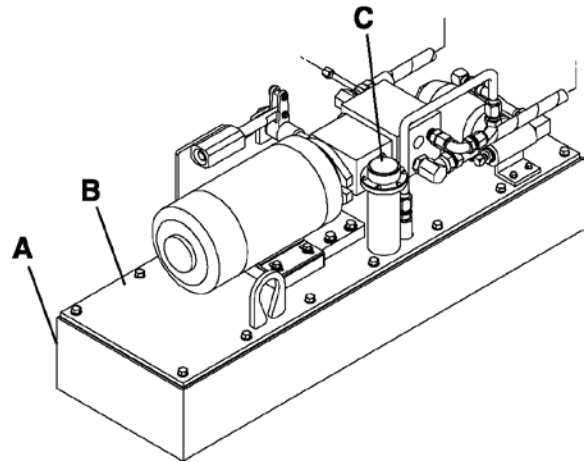

## **NOTES**

# Storage

---

## PREPARING FOR STORAGE

1. Repair worn or damaged parts.
2. Wash all equipment thoroughly.
3. Grease haul unit and dirt bucket thoroughly. Grease threads on bolts used for adjustments.
4. Drain gear box. Add Mobil SHC 630 or equivalent to notch on dip stick.
5. Drain and flush hydraulic oil from reservoir.
6. Change hydraulic filter and refill hydraulic reservoir with Mobil ISO-VG-46-20W Premium Hydraulic/Turbine Oil.
7. Remove battery pack and store in a cool, dry, well ventilated, place. Clean corrosion from cables and battery case. Charge battery packs. See “37. Perform Battery Maintenance” in the Periodic Maintenance section.
8. Repaint equipment where necessary.
9. If possible, store machine under cover and out of the weather in a ventilated area.

---

## REMOVING FROM STORAGE

1. Clean equipment thoroughly.
2. Check to make sure all decals including safety decals are clean and readable.
3. Check condition of wires and cables. Repair or replace as necessary.
4. Check gear box fluid level. Add oil as needed. See Gear Box Lubricant in Lubricants section.
5. Check hydraulic oil level. If fluid is low, check for leaks and add oil as required. See Hydraulic Reservoir Lubricant in Lubricants section.
6. Check for leaks. Repair or replace as necessary.
7. Charge battery packs. See Recharging the Battery Pack in the Operation section.
8. Review this Operator’s Manual.

## **NOTES**

# Troubleshooting

<b>Problem</b>	<b>Cause</b>	<b>Solution</b>
Haul Unit does not move.	Brake applied.	Release brake.
	Loose battery connections.	Secure battery harness and contactor harness.
	Loose wires.	Repair or replace.
	Dirty controller.	Clean controller.
	Low oil.	Add hydraulic oil.
	Leaking hydraulic hose.	Repair or replace hose.
	Dead battery.	Recharge battery or replace with spare battery pack.
	Wet contactors.	Dry contactors with contact cleaner*.
		Replace contactors.
		Replace switch.
	Pump actuator shaft not moving.	Replace broken or missing pins or linkages.
	If Haul Unit still does not move, contact your Akkerman Aftermarket Support Representative.	
Battery will not charge.	Blown charger fuse.	Replace fuse.
	Dead battery.	Check/replace battery.
	Battery charger malfunction.	Check/replace charger.
Brake does not apply.	Low brake fluid.	Add brake fluid.
	Defective master cylinder.	Replace master cylinder.
	Defective caliper.	Replace caliper.
	Defective brake pads.	Replace brake pads.
	Worn or broken linkage.	Replace linkage.
		If the brake still does not apply, contact your Akkerman Aftermarket Support Representative.

\*Contact cleaner is extremely flammable.

(Continued on next page)

<b>Problem</b>	<b>Cause</b>	<b>Solution</b>
Brake does not release after releasing brake release control.	Dirty or wet brake assembly.	Replace brake linings.
	Defective caliper.	Replace caliper.
	Linkage is binding.	Lubricate or replace linkage.
	Defective master cylinder or master cylinder linkage.	Replace master cylinder and/or linkage.
	If the brake still does not release, contact your Akkerman Aftermarket Support Representative.	
Hydraulic pump chatters when direction is selected.	Defective relief valve(s) in pump	Replace relief valves.
	Defective or worn out pump.	Replace pump.

# HAUL UNIT ELECTRICAL SCHEMATIC

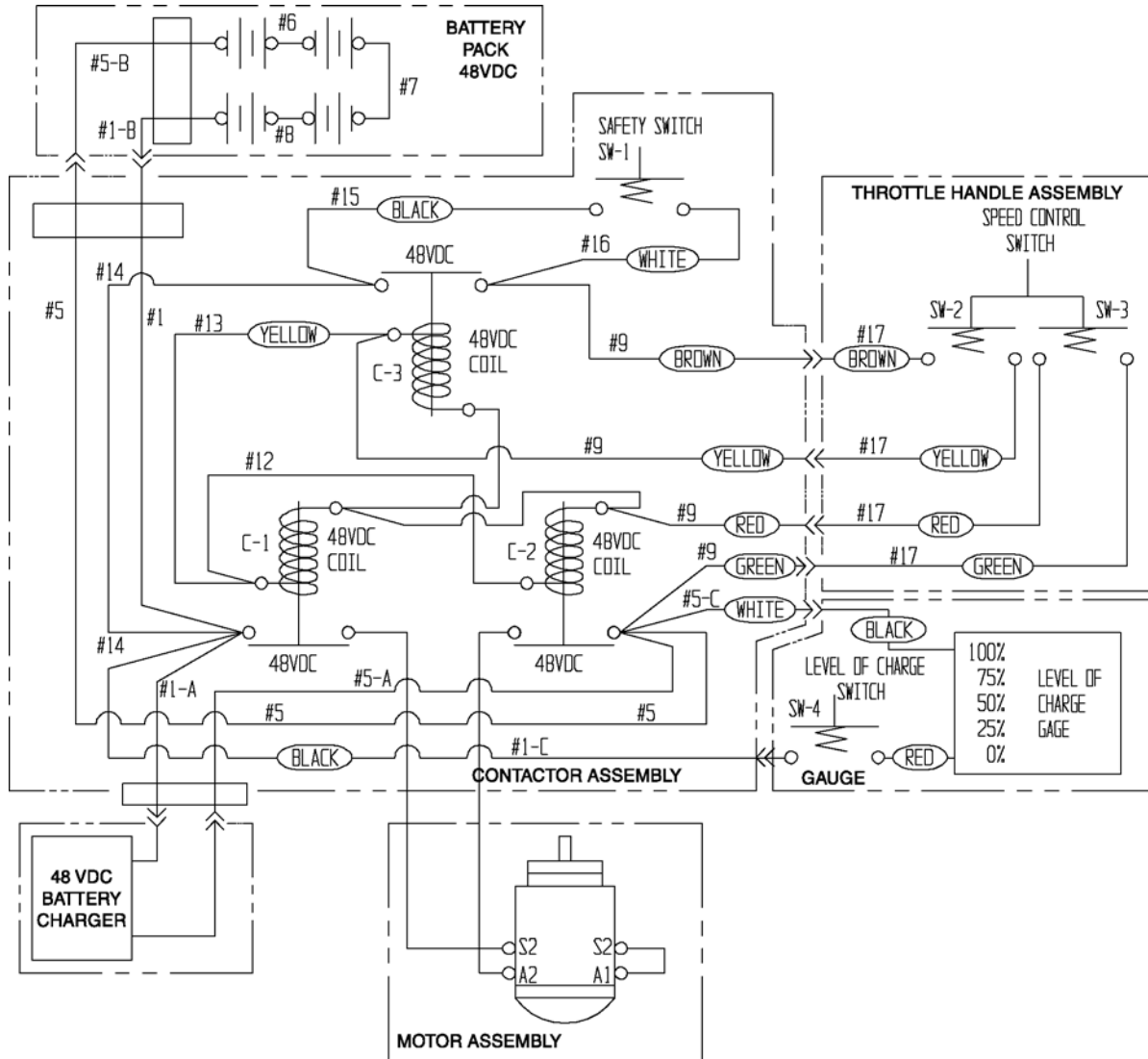

# HAUL UNIT HYDRAULIC SCHEMATIC

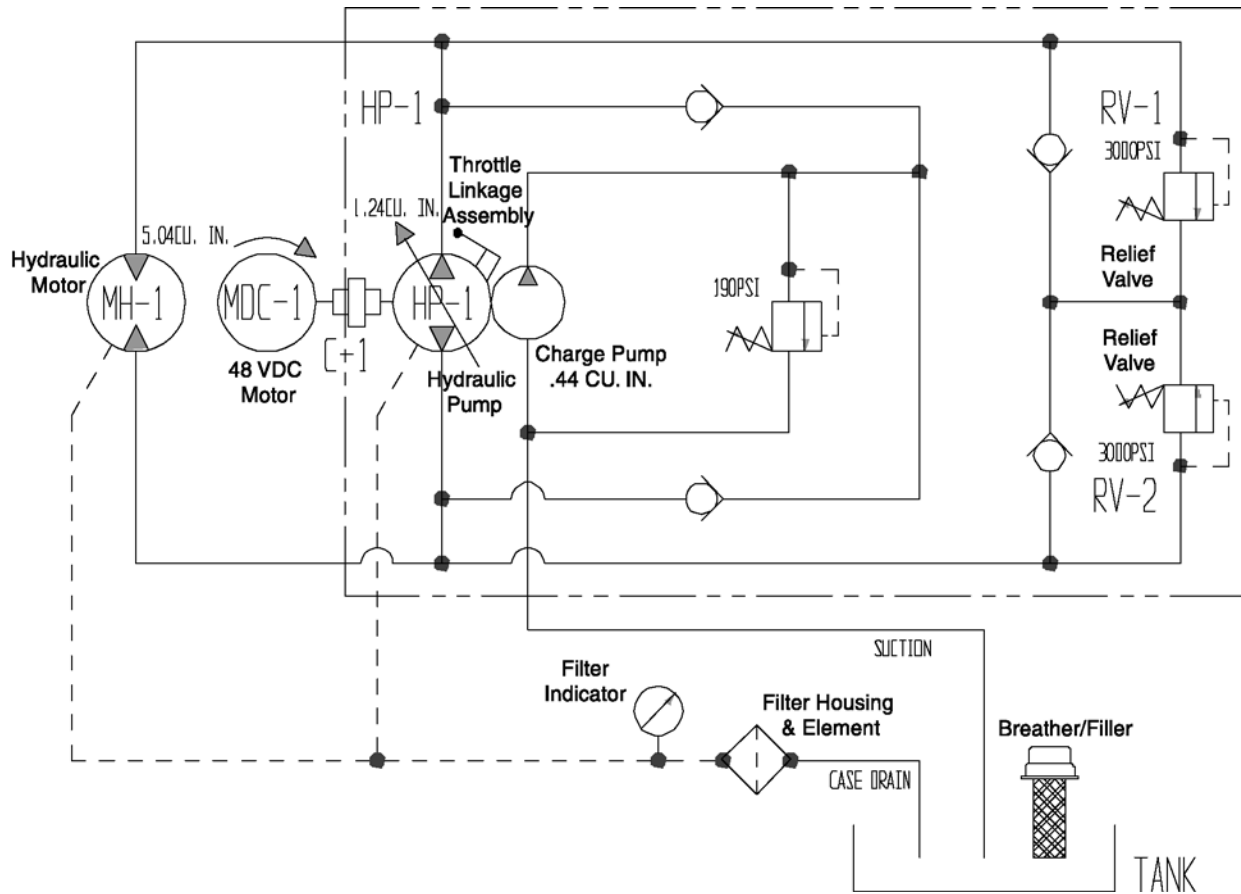

# Specifications

## 1448 HAUL UNIT

**Weight** (with battery pack) ..... 3350 lbs. (1520 kg)  
**Height** ..... 27 in. (686 mm)  
**Length**  
    Standard ..... 141.75 (4362.45 mm)  
    Extended ..... 171.75 (4362.45 mm)  
**Width** ..... 49.25 in. (1250.95 mm)  
**Wheel Base** ..... 128.2 in. (3256.28 mm)  
**Drive Wheels** ..... Two, 10" Diameter  
**Battery Pack**  
    Weight ..... 1800 lbs. (816.5 kg)  
    Voltage ..... 48 VDC  
**Electrical Horsepower** ..... 14 HP (10.4 kW)  
**Propel** ..... Forward, Reverse  
**Drive Type** ..... Electric driven, Hydrostatic  
**Hydraulics** ..... Variable Displacement Pump  
    Oil Type ..... ISO-VG-46 20W  
**Brake** ..... Hydraulic, Caliper Disk

### Speed\*

12,000 lbs. (5443 kg) Load On Level Ground  
    Feet per minute ..... 530 (161.5 m/min)  
    Miles per Hour ..... 0-6 mph (0-9.7 Km/h)

### Gear Box

Ratio ..... 1:2.85  
    Oil Capacity ..... 1 pt. (.473L)  
    Oil Type ..... Mobil SHC 630 Synthetic  
    Bearing and Gear Oil

### Maximum Haul Capacity (Bucket With Wet Sand)

780 Extended ..... 5.4 cu.yd. (4.13 m<sup>3</sup>)  
    Max. Capacity ..... 21,389 lbs (9,702 kg)

### Gross Vehicle Weight ..... 24,739 lbs (11,221 kg)

### Maximum Operating Grade

Unloaded ..... 5%  
    Loaded ..... 2.5%

### Pipe (tunnel) Size

Minimum ..... 60 in. (1524 mm)

### Track

Track Gauge ..... 20 in. (508 mm)  
    Base ..... 22.75 in. (578 mm)  
    Height ..... 3 in. (76 mm)  
    Length ..... 8 ft (2.4 L)

\* Contact your Akkerman Aftermarket Support Representative for speed ratings at various haul capacities.

## DIRT BUCKETS

Model	600	660	720	780
<b>Height</b>				
in.	41	44	45	48
(mm)	(1041)	(1118)	(1143)	(1219)
<b>Width (Dia.)</b>				
in.	55	60	64	70
(mm)	(1397)	(1524)	(1626)	(1778)
<b>Length</b>				
standard				
in.	61	-	61	-
(mm)	(1549)	-	(1549)	-
extended				
in.	90	90	90	90
(mm)	(2286)	(2286)	(2286)	(2286)
<b>Weight</b>				
standard				
lbs.	830	-	1400	-
(kg)	(376)	-	(635)	-
extended				
lbs.	1540	1540	1720	2400
(kg)	(699)	(699)	(780)	(1089)
<b>Capacity</b>				
standard				
cu. yd.	2.3	-	2.92	-
(m <sup>3</sup> )	(1.76)	-	(2.23)	-
extended				
cu. yd.	3.46	4.37	4.40	5.4
(m <sup>3</sup> )	(2.64)	(3.34)	(3.36)	(4.13)

## TORQUE CHART

Use these torque values as a guideline when tightening hardware unless otherwise specified in this manual.

Lubricated Coarse UNC Threads Grade 8 Fasteners			Lubricated Fine UNF Threads Grade 8 Fasteners		
Bolt Size	Torque ft. lbs. (N·m)		Bolt Size	Torque ft. lbs. (N·m)	
1/4 - 20	10	(14)	1/4 - 28	11	(15)
5/16 - 18	20	(27)	5/16 - 24	22	(30)
3/8 - 16	35	(47)	3/8 - 24	39	(53)
7/16 - 14	56	(76)	7/16 - 20	62	(84)
1/2 - 13	85	(115)	1/2 - 20	96	(130)
9/16 - 12	123	(167)	9/16 - 18	137	(186)
5/8 - 11	170	(231)	5/8 - 18	192	(260)
3/4 - 10	301	(408)	3/4 - 16	336	(456)
7/8 - 9	450	(610)	7/8 - 14	500	(678)
1 - 8	680	(922)	1 - 12	740	(1003)
1-1/8 - 7	960	(1302)	1-1/8 - 12	1030	(1397)
1-1/4 - 7	1360	(1844)	1-1/4 - 12	1500	(2034)
1-1/2 - 6	2360	(3200)	1-1/2 - 12	2660	(3607)



## **NOTES**

# Material Safety Data Sheets

The Federal Occupational, Safety, and Health Administration (OSHA) Standard 29 CFR 1910.1200, require that specific material safety data sheets (MSDS) be available to employees before operating this equipment. This may include information on substances contained in this equipment such as antifreeze, brake fluid, battery acid, hydraulic fluid and gear lubricant.

Akkerman Inc. will provide, at no cost, MSDS which apply to its product line. Simply contact your Akkerman Product Support representative for a copy.

To ensure a prompt response to your MSDS request, include your return address (including zip or postal code) and the equipment's model numbers and serial numbers with your request.

## **NOTES**

# Warranty

Akkerman Inc. warrants that all equipment manufactured by it be free from defects due to workmanship or material under normal use and service for a period of 90 days. This warranty does not apply to normal wear items such as cutter teeth, filters, etc. Akkerman Inc. does not warrant the fitness of its equipment for a particular purpose or application.

*Warranty*

## **NOTES**

# Index

## B

Battery Charge Indicator .....	4-1
Battery Charge Test .....	9-8
Battery Inspection .....	9-8
Battery Maintenance .....	9-19
Battery Pack, Recharging .....	6-10
Battery, Maintain Safely.....	1-2
Brake .....	4-1
Brake Fluid .....	8-1
Brake Fluid Level .....	9-7
Brake Lever, Lubrication .....	9-11
Brake Linkage Lubrication .....	9-12
Brake Test .....	9-6
Brake, Inspection.....	9-12
Bucket Door Hardware .....	9-20
Bucket, Using Dirt .....	6-7

## C

Cart, Using Haul .....	6-6
Charging Plug .....	9-17
Chart, Torque .....	12-2
Charts, Maintenance .....	9-2
Clean/Inspect Equipment .....	1-3
Clothing, Protective .....	1-1
Contact, Conveyor .....	1-5
Contact, Tunnel Wall .....	1-4
Contacting Maintenance .....	9-9
Contents .....	ii
Controller .....	4-1
Controller Inspection .....	9-9
Controls & Instruments.....	4-1
Conveyor Contact .....	1-5
Cover, Inspection .....	9-8

## D

Decals, Safety .....	2-1
Dirt Bucket, Using .....	6-7
Dirt Bucket, Reconfiguring Haul Unit Frame For ..	6-9

## E

Electric Motor Mounting .....	9-17
Electrical Schematic .....	11-3
Equipment, Clean/Inspect .....	1-3
Exposure, Laser Light .....	1-6

## F

Fire Prevention .....	1-2
Fluid, Brake .....	8-1
Frame Rails .....	9-14
Frame, Reconfiguring Haul Unit .....	6-9

## G

Gear Box .....	9-16
Gear Box Fluid Level .....	9-6
Gear Box Lubricant .....	8-1
Gear Box Mounting Torque .....	9-11
Gear Box Pressure Relief .....	9-16
Gear Box Wheel & Bearings Inspection .....	9-11
Gear Box, Inspection .....	9-6
Grease .....	8-2
Guidelines, Operating .....	6-1

## H

Haul Cart Inspection .....	9-20
Haul Cart Wheel Bearing Lubrication .....	9-20
Haul Cart, Using .....	6-6
Haul Unit Set Up .....	6-2
Haul Unit Electrical Schematic .....	11-3
Haul Unit Frame, Reconfiguring .....	6-9
Haul Unit Operation .....	6-4
Haul Unit, Parking .....	6-6
Haul Unit, Riders .....	1-3
Haul Unit, Stopping .....	6-6
Hinge Lubrication .....	9-14
Hinge Pin Hardware .....	9-15
Hose Inspection .....	9-12
Hydraulic Filter Check .....	9-10
Hydraulic Filter Indicator .....	4-2
Hydraulic Motor Mounting .....	9-17
Hydraulic Oil Under Pressure .....	1-2
Hydraulic Reservoir .....	9-21
Hydraulic Reservoir Lubricant .....	8-1
Hydraulic Reservoir Oil Level .....	9-9
Hydraulic Schematic .....	11-4

## I

Identification Numbers .....	13-1
Idler Assembly Wheels/Bearings Inspection ..	9-13
Idler Axle Pivot Pin Lubrication .....	9-13
Idler Wheel Bearings Lubrication .....	9-13
Indicator, Battery Charge .....	4-1
Indicator, Hydraulic Filter .....	4-2
Information, Safety .....	1-1
Inspect/Clean Equipment .....	1-3
Inspection, Pre-Start .....	5-1
Installing Track .....	6-3
Instruments & Controls .....	4-1
Introduction.....	i

## J

Job Site Clean & Organized .....	1-7
----------------------------------	-----

Index

**L**

Laser Light Exposure ..... 1-6  
Light Exposure, Laser ..... 1-6  
Loads, Suspended ..... 1-4  
Lockout Power Before Servicing ..... 9-1  
Lockout Power ..... 1-4  
Lubricant Storage ..... 8-2  
Lubricants ..... 8-1

**M**

Maintenance ..... 9-1  
Maintenance Charts ..... 9-2  
    Daily or Every 10 Hours or Shift Change ..... 9-2  
    Weekly or Every 50 Hours ..... 9-3  
    Monthly or Every 250 Hours ..... 9-4  
    Every 500 Hours Or When Engulfed W/Water ..... 9-5  
Maintenance Service Detail  
    Daily or Every 10 Hours or Shift Change ..... 9-6  
    Weekly or Every 50 Hours ..... 9-11  
    Monthly or Every 250 Hours ..... 9-16  
    Every 500 Hours Or Engulfed With Water ... 9-21  
Maintenance, Battery ..... 9-19  
Maintenance, Periodic ..... 9-1  
Maintenance, Practice Safe ..... 1-3  
Manual, Read ..... 1-1  
Master Cylinder Fluid Level ..... 9-7  
Material Safety Data Sheets ..... 14-1  
Motor Brushes ..... 9-17  
Mounting, Electric Motor ..... 9-17  
Mounting, Hydraulic Motor ..... 9-17  
MSDS ..... 14-1

**N**

Numbers, Identification ..... 13-1  
Numbers, Serial ..... 13-1

**O**

Operating Guidelines ..... 6-1  
Operating The Haul Unit ..... 6-4  
Operation ..... 6-1  
Operator Platform Inspection ..... 9-7

**P**

Pack, Recharging Battery ..... 6-10  
Parking The Haul Unit ..... 6-6  
Periodic Maintenance ..... 9-1  
Pillow Block Bearings Lubrication ..... 9-11  
Pivot Linkage Lubrication ..... 9-13  
Power Lockout ..... 1-4  
Practice Safe Maintenance ..... 1-3  
Pressure, Hydraulic Oil ..... 1-2  
Pre-Start Inspection ..... 5-1  
Prevention, Fire ..... 1-2  
Protective Clothing ..... 1-1

**R**

Rails, Frame ..... 9-14  
Read Manual ..... 1-1  
Recharging Battery Pack ..... 6-10  
Recycle Waste ..... 1-6  
Reservoir, Hydraulic ..... 9-21  
Riders, Haul Unit ..... 1-3

**S**

Safe Maintenance, Practice ..... 1-3  
Safety ..... 1-1  
Safety Decals ..... 2-1  
Safety Information ..... 1-1  
Schematic, Electrical ..... 11-3  
Schematic, Hydraulic ..... 11-4  
Seat Mounting Check ..... 9-8  
Serial Numbers ..... 13-1  
Servicing, Lockout Power ..... 1-4, 9-1  
Setting Up Haul Unit ..... 6-2  
Slippery When Wet ..... 1-7  
Smoking ..... 1-6  
Specifications ..... 12-1  
Stopping The Haul Unit ..... 6-6  
Storage ..... 10-1  
Storing Lubricants ..... 8-2  
Suspended Loads ..... 1-4  
Switching Haul Unit Frame ..... 6-9

**T**

Terminology ..... 3-1  
Test Tunnel Ventilation ..... 1-5  
Throttle Control Linkage Lubrication ..... 9-18  
Torque Chart ..... 12-2  
Torque, Gear Box Mounting ..... 9-11  
Track, Inspection ..... 9-10  
Track, Installing ..... 6-3  
Transporting ..... 7-1  
Troubleshooting ..... 11-1  
Tunnel Ventilation, Test ..... 1-5  
Tunnel Wall Contact ..... 1-4

**U**

Unauthorized Welding ..... 1-6  
Using Dirt Bucket ..... 6-7  
Using the Haul Cart ..... 6-6

**V**

Ventilation, Test Tunnel ..... 1-5

**W**

Wall Contact, Tunnel ..... 1-4  
Warranty ..... 15-1  
Waste, Recycle ..... 1-6  
Welding, Unauthorized ..... 1-6