



# **OPERATOR'S MANUAL**

## **524 Haul Unit System**

**Haul Unit S/N: F10325F, F16900F, F25865F**

**Publication No. 050001A00**

Rev. No. 011221, 100715, 240331

© Akkerman Inc. 2001, 2010, 2024  
All Rights Reserved

Akkerman Inc. 58256 266th Street Brownsdale, MN 55918  
Phone: 507-567-2261 Fax: 507-567-2605 email: [akk@akkerman.com](mailto:akk@akkerman.com)

**SERVICE • RELIABILITY • INNOVATION**



# Introduction

This operator's manual contains important safety, operation, and maintenance information for your Akkerman 524 Haul Unit System. This system includes the 524 Haul Unit, Dirt Bucket, Haul Cart, and Track. You must read and understand this manual before you operate and maintain this equipment. Keep this manual with your Haul Unit at all times. Additional copies of this manual may be purchased from the Akkerman Aftermarket Support Department, or downloaded from the Akkerman web site at [www.akkerman.com](http://www.akkerman.com).

The contractor is responsible for the overall safety program on the job site. Use this manual as a part of the safety program.

The use of second rate parts could affect the efficient performance of the Haul Unit System. ALWAYS use genuine Akkerman parts.

Understand safety signal words, DANGER, WARNING, CAUTION, SAFETY INSTRUCTIONS, and NOTICE. When you see these words in this manual or on safety decals mounted on your equipment, follow the safety message to avoid personal injury and/or property damage.

**▲ DANGER** Indicates an extremely hazardous situation which, if not avoided, WILL result in death or serious injury.

**▲ WARNING** Indicates a potentially hazardous situation which, if not avoided, COULD result in death or serious injury.

**▲ CAUTION** Indicates a potentially hazardous situation, which, if not avoided, MAY result in minor or moderate injury. It may also be used to alert against unsafe practices.

**SAFETY INSTRUCTIONS** Usually consists of individual messages stating procedures or actions that must be followed for the safe operation of a product.

**NOTICE** Identifies potential property damage and important installation, operator, or maintenance information.



## 524 Haul Unit with Dirt Bucket

The 524 Haul Unit System transports the spoil from the Tunnel Boring Machine back to the launch shaft. The typical Akkerman system is comprised of a haul unit, track and dirt bucket.

The 524 haul unit is electrically powered with a removable battery pack.

Dirt buckets are designed for maximum capacity based on the size of pipe or tunnel being installed. They are self-dumping when using a two-line crane or by attaching a stationary line.

The track sections are lightweight, yet sturdy. The tracks are quick to connect with a single bolt and wing nut. Storage racks are available for convenient shipping and handling.

If you find any errors with this manual or know of ways to improve procedures, please let us know.

Mail your suggestions to: ATTN: Technical Publications  
Akkerman Inc., 58256 266th Street, Brownsdale, MN 55918

Akkerman Inc. reserves the right to improve its product without notice or obligation.

# Contents

<b>Safety</b> .....	<b>1-1</b>	<b>Transporting</b> .....	<b>7-1</b>
Be Alert For Safety Information .....	1-1	<b>Lubricants</b> .....	<b>8-1</b>
Read Operator's Manual .....	1-1	Gear Reducer Gear Box Lubricant .....	8-1
Wear Protective Clothing .....	1-1	Hydraulic Brake Fluid .....	8-1
Keep First-Aid Kit Accessible .....	1-1	Grease .....	8-1
Fire Prevention .....	1-2	Storing Lubricants .....	8-2
Maintain Battery Safely .....	1-2	<b>Periodic Maintenance</b> .....	<b>9-1</b>
Keep Riders Off Haul Unit .....	1-2	Lockout Tagout Power Before Servicing .....	9-1
Keep Personnel Away From Moving Parts .....	1-3	Maintenance Charts .....	9-2
Beware of Suspended Loads .....	1-3	Daily or Every 10 Hours or Shift Change ...	9-2
Regularly Clean/Inspect Equipment .....	1-3	Weekly or Every 50 Hours .....	9-3
Practice Safe Maintenance .....	1-3	Monthly or Every 250 Hours .....	9-4
Avoid Tunnel Wall Contact .....	1-4	Maintenance Procedures .....	9-5
Test Tunnel Ventilation .....	1-4	Daily or Every 10 Hours or Shift Change ...	9-5
Lockout Tagout Power Before Servicing .....	1-5	Weekly or Every 50 Hours .....	9-9
Keep Away From Conveyors .....	1-5	Monthly or Every 250 Hours .....	9-15
Watch For Conveyor .....	1-5	<b>Storage</b> .....	<b>10-1</b>
No Smoking In Tunnel .....	1-5	<b>Troubleshooting</b> .....	<b>11-1</b>
Avoid Laser Light Exposure .....	1-6	General Troubleshooting .....	11-1
Unauthorized Welding .....	1-6	Haul Unit Electrical Schematic .....	11-2
Slippery When Wet .....	1-6	<b>Specifications</b> .....	<b>12-1</b>
Recycle Waste .....	1-6	General Specifications .....	12-1
<b>Safety Decals</b> .....	<b>2-1</b>	Torque Chart .....	12-2
<b>Terminology</b> .....	<b>3-1</b>	<b>Identification Numbers</b> .....	<b>13-1</b>
<b>Controls &amp; Instruments</b> .....	<b>4-1</b>	<b>Safety Data Sheets</b> .....	<b>14-1</b>
Controller Location .....	4-1	<b>Warranty</b> .....	<b>15-1</b>
Controller Functions .....	4-1	<b>Index</b> .....	<b>16-1</b>
Hydraulic Hand Brake .....	4-2		
<b>Pre-Start Inspection</b> .....	<b>5-1</b>		
<b>Operation</b> .....	<b>6-1</b>		
Operating Guidelines .....	6-1		
Setting Up The Haul Unit .....	6-2		
Installing Track .....	6-3		
Adjust Steering Haul Unit For Steering .....	6-4		
Operating The Haul Unit .....	6-6		
Using the Dirt Bucket .....	6-8		
Using the Inspection Cart .....	6-9		
Recharging The Battery Pack .....	6-10		

# Safety

---

## BE ALERT FOR SAFETY INFORMATION

When you see this safety alert symbol on your equipment or in this manual, be alert to the possibility of personal injury or property damage.

Read all safety information.

Keep safety decals clean and in good condition. Replace missing or damaged safety decals.



**ATTENTION!  
BECOME ALERT!  
YOUR SAFETY IS INVOLVED!**

---

## READ OPERATOR'S MANUAL

**⚠ WARNING** Unsafe operation or maintenance can cause severe injury or death.

Read and understand the Operator's Manual before operating or servicing this equipment.

Any unauthorized modifications will void the warranty.

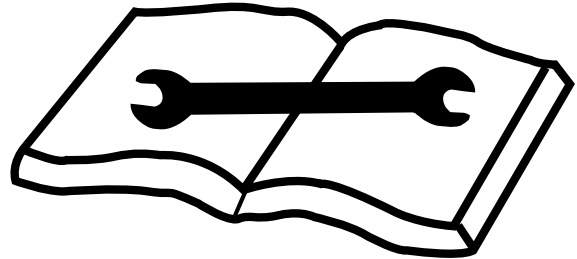

---

## WEAR PROTECTIVE CLOTHING

Wear OSHA approved protective clothing, such as hard hat, gloves, safety goggles, earmuffs or ear plugs, face shield, and steel-toed boots, when operating and servicing this equipment.

Wear reasonably close fitting clothing and remove jewelry before working on or near this equipment. This will help prevent the danger of catching them in moving parts or controls.



---

## KEEP FIRST-AID KIT ACCESSIBLE

Keep a first-aid kit handy and properly maintained. Call 9-1-1 for emergencies.

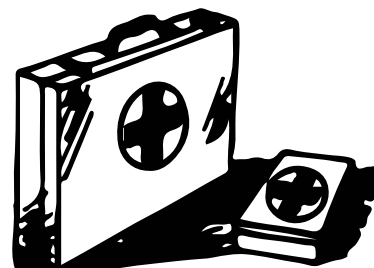

---

## FIRE PREVENTION

**⚠ CAUTION** Fires can cause injury or property damage.

Keep equipment clean. Remove all debris from equipment.

Have a fire extinguisher available at all times. Keep the fire extinguisher fully charged.



---

## MAINTAIN BATTERY SAFELY

**⚠ WARNING** Batteries produce explosive gases.

Wear eye protection and protective clothing during battery service.

Keep sparks, flames, and cigarettes away from batteries.

Contact with battery acid can cause severe burns. Flush immediately and thoroughly with clean water. Get medical attention immediately.

Charge a battery ONLY in a well-ventilated area.

Never charge a frozen battery.

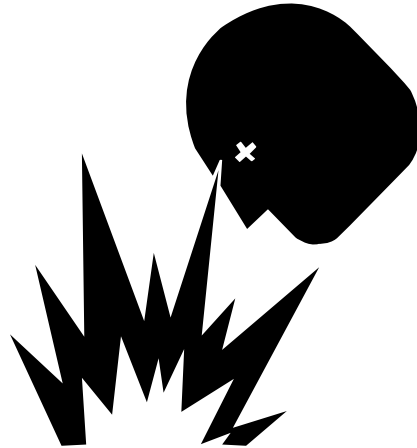

---

## KEEP RIDERS OFF HAUL UNIT

Allow only operator on operating platform when moving haul unit. Keep riders off.

Riders on haul unit can be easily injured by being struck by objects or being thrown off of the equipment. Riders can also obstruct the operator's view resulting in the equipment being operated in an unsafe manner.

A rider may be allowed in an empty dirt bucket (with contractor approval only), to transport personnel from the tunnel opening to the boring head. If allowed, the rider MUST be fully inside dirt bucket, including head and all other body parts, to avoid contact with obstructions. Also, rider cannot obstruct the operator's view.

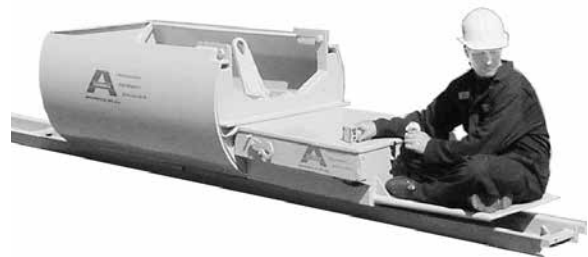

---

## KEEP PERSONNEL AWAY FROM MOVING PARTS

**⚠ WARNING** Crushing hazard.

Keep personnel away from inside of yoke, on skid, or behind pump unit when jacking or moving pump unit or yoke. Failure to do so could result in serious personal injury or death.

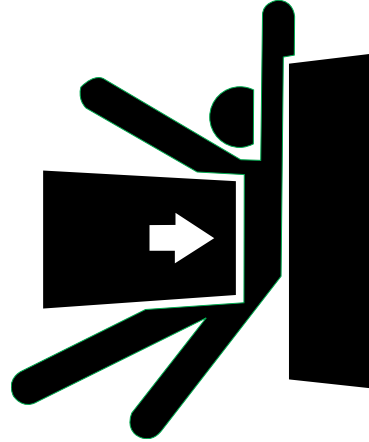

---

## BEWARE OF SUSPENDED LOADS

**⚠ WARNING** Suspended loads may fall and cause severe personal injury or death.

If a hydraulic hose, chain, or cable from the boom of a crane or excavator breaks, the boom can fall instantly.

Do not enter area under or around a load.

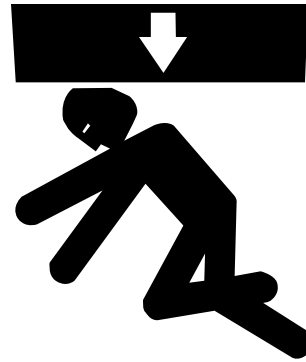

---

## REGULARLY CLEAN AND INSPECT EQUIPMENT

Remove any grease, oil, or debris buildup to avoid potential injury or equipment damage.

Inspect equipment for damage. If damaged, repair or replace immediately.



---

## PRACTICE SAFE MAINTENANCE

LOCKOUT TAGOUT power before performing any maintenance by disconnecting battery harness from contactor harness and remove battery pack from haul unit.

Keep the area around the equipment clean and dry when performing maintenance.

Do not service the machine while it is in motion.

Replace worn or damaged parts. Remove grease, oil, or debris buildup.

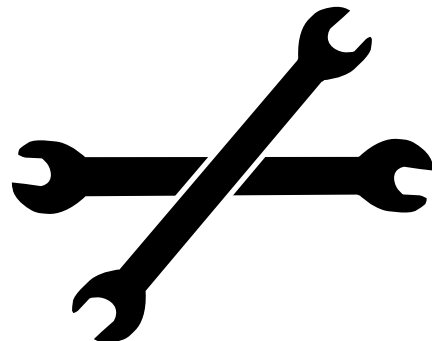

---

## AVOID TUNNEL WALL CONTACT

**⚠ WARNING** Contacting tunnel wall and boring head components can cause severe personal injury or death.

Keep all body parts on Haul Unit while Unit is moving (as shown in photograph).

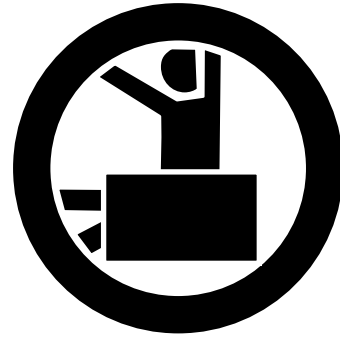

---

## TEST TUNNEL VENTILATION

**⚠ WARNING** Keep Boring Head and tunnel well ventilated at all times.

Use an approved air analyzer to detect hazardous gases and oxygen content.

Before and during the tunnel operation, test for combustible and toxic gases and oxygen deficiency.

If the levels exceed OSHA prescribed levels, leave tunnel immediately! Do not activate or deactivate any electrical or hydraulic devices, since any sparks could cause an explosion.

Once ALL personnel is out of tunnel, cut power from power source.

Gases must be removed before reentering tunnel.

Do not use Haul Unit to evacuate the tunnel. The electrical contacts with the unit can cause an explosion.

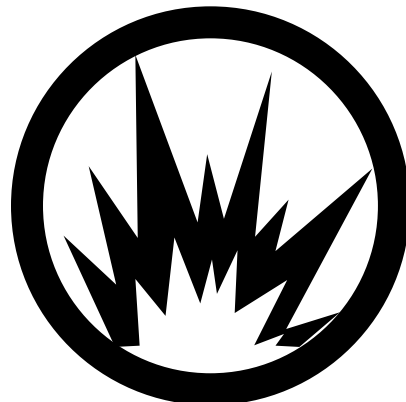
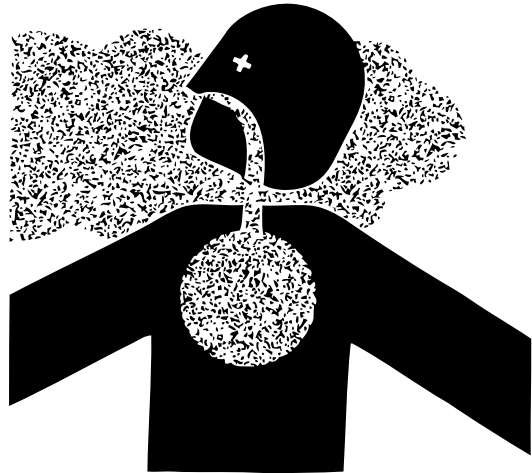

---

## LOCKOUT TAGOUT POWER BEFORE SERVICING

**⚠ WARNING** Unexpected haul unit startup or machine movement can result in severe personal injury or death.

LOCKOUT TAGOUT power before attempting to make repairs or adjustments to this equipment, unless otherwise indicated. Proper lockout tagout will prevent accidents and save lives. Performing lockout tagout will also prevent the equipment from moving unexpectedly. To lockout tagout, disconnect battery harness from contactor harness and remove battery pack from haul unit.

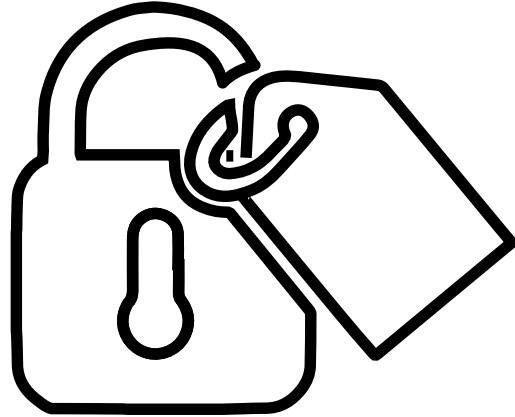

---

## KEEP AWAY FROM CONVEYORS

**⚠ DANGER** Contact with rotating auger conveyor or conveyor belt idler rollers, will cause severe injury or death.

Keep hands, body, and objects clear of operating auger and conveyor.

Do not operate without covers and guards in place.

Lockout tagout power before servicing.

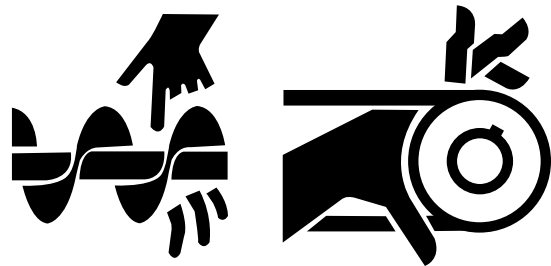

---

## WATCH FOR CONVEYOR

**⚠ WARNING** Avoid contact with conveyor. Failure to do so could cause severe injury or death.

While moving haul unit into tunnel, avoid hitting the conveyor.

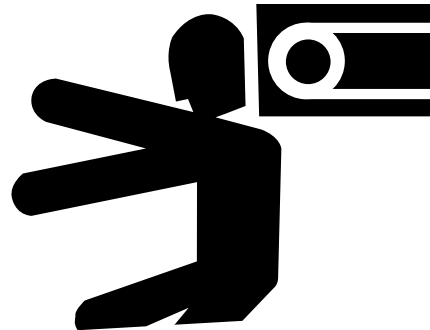

---

## NO SMOKING IN TUNNEL

**⚠ WARNING** Smoking in tunnel could cause an explosion if combustible gases are present.

Do not smoke in tunnel.



---

## AVOID LASER LIGHT EXPOSURE

**⚠ DANGER** Staring into laser light will cause severe injury.

Do not stare into laser guidance system light beam. Avoid direct eye exposure.

To avoid possible exposure to radiation in excess of acceptable emission limits, all repairs to laser must be performed by the original manufacturer or an authorized service technician.

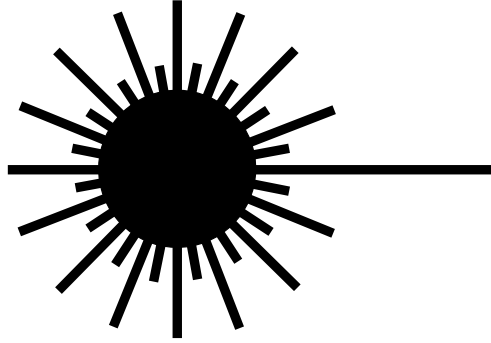

---

## UNAUTHORIZED WELDING

**⚠ WARNING** Unauthorized welding can cause structural failure and/or electrical system damage resulting in possible injury or death.

Do not weld on any structural member. Unauthorized welding or repair will void the warranty.

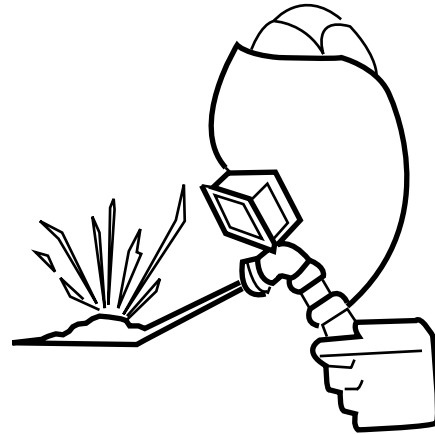

---

## SLIPPERY WHEN WET

**⚠ WARNING** Slips and falls can cause serious personal injury.

Ensure firm footing in wet or slippery conditions.

Replace skid-resistant material if it is damaged or missing to prevent slips and falls.

Remove any buildup of grease, oil, or debris.



---

## RECYCLE WASTE

Follow local, state, federal, and international regulations when recycling or disposing of waste. Waste includes fluids/oil, fuel, filters, coolant, and batteries.

Use leakproof containers when draining fluids/oil. Do not pour waste on the ground, down a drain, or into any water source.

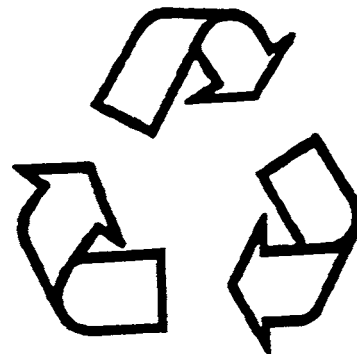

# Safety Decals

Keep all safety decals clean and readable. Use soft cloth, water, and a mild soap to clean the decals if they are too dirty to read. DO NOT clean safety decals with solvent. Solvent can damage them. Replace safety decals immediately if they are damaged, missing, or hard to read.

Serious injury or property damage can occur if safety instructions are not followed. Contact your Akkerman Aftermarket Support representative for free replacement safety decals.

If a part is replaced that has a safety decal on it, apply a new safety decal to the replacement part. Before applying a new decal, be sure the surface is clean and dry.

**WARNING**  
Spraying cleaners on brake caliper may cause rubber seals to swell, shrink or dissolve resulting in serious personal injury or death from brake malfunction.  
DO NOT spray cleaners on caliper assembly.  
1250-088

**WARNING**  
Batteries produce explosive gases.  
Wear eye protection and protective clothing during battery service.  
Keep sparks, flames, and cigarettes away from batteries.  
1251-063 0908

**WARNING**  
Touching electrical contactors can cause an electrical shock.  
Keep guard in place.  
1250-875

**WARNING**  
A dirty controller can cause improper Haul Unit operation resulting in severe personal injury or death.  
Keep controller clean.  
Avoid contact with water.  
1250-379a 9/01

**524 HAUL UNIT ELECTRICAL SCHEMATIC**  
The schematic diagram shows the electrical system components including the battery pack, controller, motor, and various sensors and switches.

**WARNING**  
Contacting tunnel wall and boring head components can cause severe personal injury or death.  
Keep all body parts on Haul Unit while Unit is moving.

**WARNING**  
Suspended loads may fall and cause severe personal injury or death.  
Do not enter area under or around a load.  
1250-500 9/01

**WARNING**  
Batteries produce explosive gases.  
Wear eye protection and protective clothing during battery service.  
Keep sparks, flames, and cigarettes away from batteries.  
1250-063 9/01

**NOTES**

# Terminology

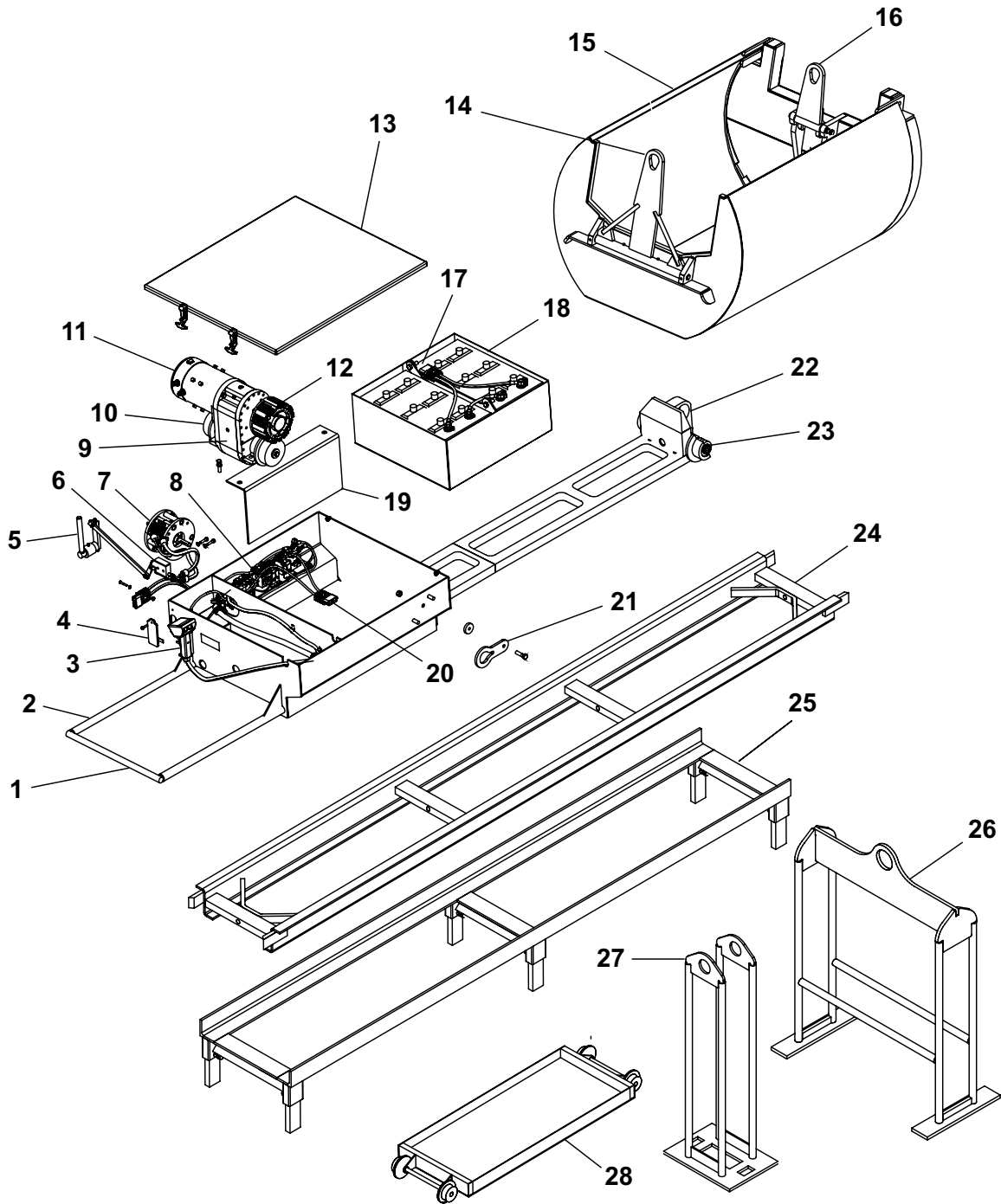

- |                                |                               |                     |
|--------------------------------|-------------------------------|---------------------|
| 1. Main Frame                  | 11. Electric Motor            | 21. Lifting Eye     |
| 2. Operator Platform           | 12. Electric Brake            | 22. Idler Assembly  |
| 3. Controller                  | 13. Battery Compartment Cover | 23. Idler Wheel     |
| 4. Charger Plate/Charger Plug  | 14. Bucket Lift Eye           | 24. Z Track         |
| 5. *Hand Brake Control         | 15. Dirt Bucket               | 25. Track Riser     |
| 6. *Hand Brake Master Cylinder | 16. Door Lift Eye             | 26. Track Carrier   |
| 7. *Hydraulic Brake Assembly   | 17. Battery Harness           | 27. Riser Carrier   |
| 8. Electrical Assembly         | 18. Battery Pack, 24 Volt DC  | 28. Inspection Cart |
| 9. Gear Reducer Assembly       | 19. Contactor Shield          |                     |
| 10. Wheel                      | 20. Contactor Harness         |                     |

\* SN F10325F-86 & After

## **NOTES**

# Controls & Instruments

## CONTROLLER LOCATION

Controller (A) is shown in the operating position.

(SN 10325F-85 & Before) The controller should be stored on tray assembly (B) to help prevent water and dirt from damaging controller.

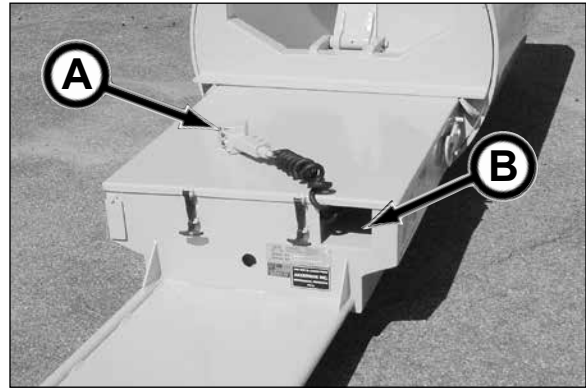

(SN 10325F-86 & After) When shipping the haul unit or when the haul unit is not in use, store controller (C) inside haul unit.

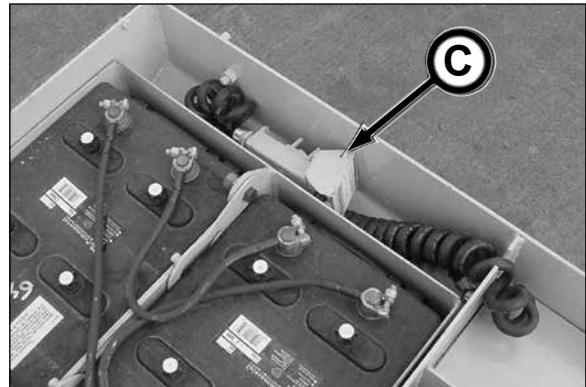

## CONTROLLER FUNCTIONS

### *BRAKE RELEASE*

The 524 Haul Unit is equipped with a electric brake that will hold the load until electrically released with brake release switch (D).

### *CONVENTIONAL CONTROL OPERATION*

In a conventional haul unit operation, the haul unit goes into the pipeline first, then the dirt bucket.

To enter tunnel, press brake release (D), then press IN switch (E). To stop, release both switches.

To exit tunnel, press brake release (D), then press OUT switch (F). To stop, release both switches.

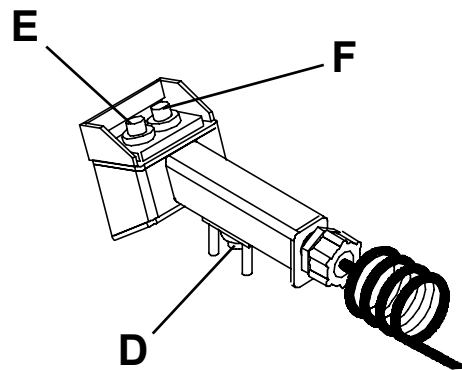

D - Brake Release E - IN Tunnel F - OUT Tunnel  
**CONVENTIONAL CONTROL OPERATION**

### *NONCONVENTIONAL CONTROL OPERATION*

In a nonconventional haul unit operation, the dirt bucket goes into the pipeline first, then the haul unit.

To enter tunnel, press brake release (D), then press IN switch (F). To stop, release both switches.

To exit tunnel, press brake release (D), then press OUT switch (E). To stop, release both switches.

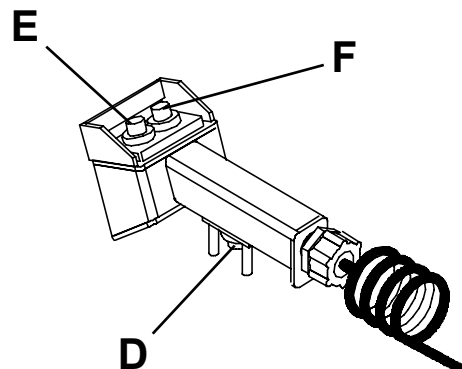

D - Brake Release E - OUT Tunnel F - IN Tunnel  
**NONCONVENTIONAL CONTROL OPERATION**

## HYDRAULIC HAND BRAKE (SN F10325F-86 & AFTER)

### NOTICE

A hydraulic hand brake retrofit kit for haul units SN F10325F-85 & before is available. Contact your Akkerman Aftermarket Support representative for more information.

Pull lever (A) (towards operator) to engage hydraulic disc brake.

Release lever to disengage hydraulic disc brake.

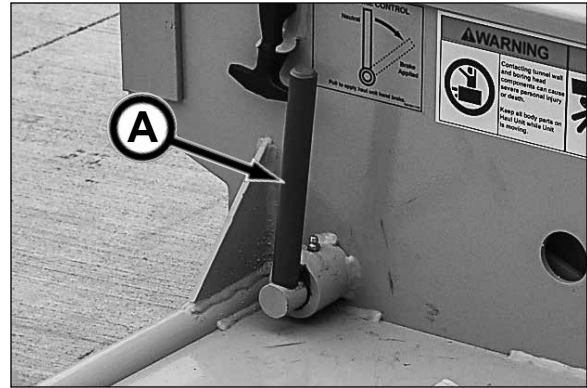

# Pre-Start Inspection

## **⚠WARNING**

Do not operate this equipment until you read, study, and understand this manual. A daily inspection of the equipment must be performed to prevent severe personal injury or death and equipment damage.

**The contractor is fully responsible for the safety of all personnel on the job site.** Check with the contractor that all site preparation requirements are in place. Be sure to comply with all OSHA regulations, such as: an active safety program is in practice, a confined space permit (if needed) is issued, personal protective equipment is being worn; flammable, combustible, and hazardous materials are properly stored; and a lockout tagout procedure is in place.

Use the following checklist ✓ as a guide for your daily pre-start inspection. Make a copy of this Pre-Start Inspection checklist. Once it is complete, check off, initial and date each item and file the copy as a record of maintenance.

	1. Use "ONE-CALL" notification to check for buried utility lines prior to tunneling.
	2. Contractor is responsible for all personnel to wear proper protective equipment on the job site. Replace equipment if defective.
	3. Check the excavated launch and reception shafts for proper shoring or bracing to prevent slides or cave-ins.
	4. Thoroughly clean equipment of mud and dirt.
	5. Remove combustible or flammable materials from equipment. Store materials properly.
	6. Test air monitoring and ventilation detectors for proper operation.
	7. Inspect track, haul unit, and dirt bucket for damage. Repair or replace as needed.
	8. Check to be sure each track section joint is properly fastened.
	9. Check haul unit drive wheels for damage. If damaged, replace wheels.
	10. Be sure all covers and guards are in place before operation.
	11. Check that the self-dumping dirt bucket door moves freely and operates correctly.
	12. Practice operating the haul unit to get the "feel" of the equipment. Check for speed and braking technique.
	13. Check to be sure the brake fluid in the master cylinder is properly filled. Use only DOT 3 Brake Fluid.
	14. Check to be sure brakes (electrical and hydraulic) engage and release properly.
	15. Check to be sure controller works properly before operating. Repair or replace as needed.
	16. Check controller for damage. Repair or replace as needed.
	17. Check controller cord for damage. Repair or replace cord as needed.
	18. Check to be sure contactor shield is in place. If damaged, replace with new.
	19. Check battery electrolyte level. Refer to battery manufacturer instructions.
	20. Check for loose or missing hardware. Replace damaged or missing hardware.
	21. Check for worn, loose, or damaged wire connections. Repair or replace wiring.
	22. Tighten loose clamps or fittings.
	23. Check battery harness and contactor harness connectors for a secured connection.
	24. Check wire harnesses for frayed or worn insulation or wires. Replace damaged or worn harnesses.
	25. Check battery charge level on haul unit before operating.
	26. Check spare battery pack for full charge. Recharge, if needed.
	27. Check for fluid leaks. Repair leak or replace hoses or components.
	28. Check condition of lift eyes on haul unit, battery pack and dirt bucket. Replace if damaged.
	29. Keep job site clean and organized.
	30. Check equipment for proper lubrication. Refer to Section 9, Periodic Maintenance.

## **NOTES**

# Operation

## OPERATING GUIDELINES

### **⚠WARNING**

Do not operate this equipment until you read, study, and understand this manual. Failure to do so, could result in severe personal injury or death.

1. Before operating, read and understand the Safety, Pre-Start Inspection, and Operation sections.
2. Do not operate this equipment while under the influence of alcohol, drugs, or medication.
3. Follow all Federal, State, and Local safety regulations and procedures.
4. Be sure OSHA prescribed safety protective equipment is being worn by all personnel.
5. Be sure the area is safe for operation. Keep worksite clean and orderly.
6. NEVER operate equipment if it has been engulfed with water. Contact your Akkerman Aftermarket Support representative for proper procedures on how to restore equipment for operation.
7. Have a fully charged fire extinguisher on the job site at all times.
8. Before operating, repair equipment problems.
9. Be sure the excavated launch and reception shafts are properly shored or braced to prevent slides or cave-ins.
10. Test air monitoring and ventilation detectors for proper operation. Never enter a tunnel without detectors.
11. Before operation, determine whether the job site has confined spaces. Follow OSHA regulations for proper training required for employees working in and around confined spaces.
12. A fully trained and qualified signal person must direct the excavator or crane operator when lifting and lowering the haul unit, dirt bucket, and other equipment.
13. Never walk or work under any part of the excavator or crane and suspended loads, such as pipe or dirt bucket.
14. Never operate the haul unit without being completely on the operator platform.
15. Practice operating the controls to make sure they work properly and to get the “feel” of the speed and braking of the haul unit.
16. When using haul unit to enter or exit a tunnel, watch out for personnel and do not run into obstacles.
17. No riders are allowed on the haul unit. Riders can fall from equipment or be injured by unexpected movement, resulting in severe injury or death. A rider may be allowed in an empty dirt bucket (**with contractor approval only**), to transport personnel from the tunnel opening to the boring head. If allowed, the rider **MUST** be fully inside dirt bucket, including head and all other body parts, to avoid contact with obstructions. Also, rider cannot obstruct the operator’s view.
18. Beware of pinch points.
19. If this manual is lost, contact your Akkerman Aftermarket Support representative for a new manual or download this manual from the Akkerman web site at [www.akkerman.com](http://www.akkerman.com).
20. Do not operate this equipment on a grade higher than 5% unloaded or 2.5% loaded. The unloaded equipment grade can be visualized by a 1/2 foot (6 in.) drop or rise in a 10 foot distance. The loaded equipment grade can be visualized by a 1/4 foot (3 in.) drop or rise in a 10 foot distance.
21. Do not operate with loose objects on the operator platform, battery compartment cover and drive box cover, such as tools or parts.

## SETTING UP THE HAUL UNIT

1. Once the Tunnel Boring Machine (TBM) has been setup with: power unit, jacking system, conveyor, and laser guidance system; install track and track risers as needed (see Installing Track in this section).

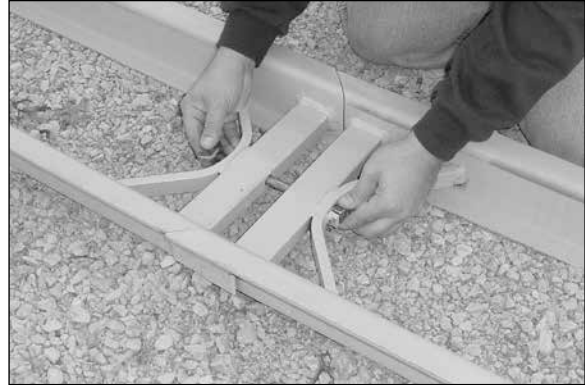

### NOTICE

In certain applications, the dirt bucket will need to be lowered into position behind the conveyor until the TBM has moved far enough forward to allow enough room to lower the haul unit.

2. Using the lifting eyes (A), lower the haul unit without the battery pack, onto the jacking system rails or track. The operator platform end of the haul unit should be positioned towards the TBM.
3. Inspect the area for clearance between the haul unit frame and the dirt bucket unloading area.

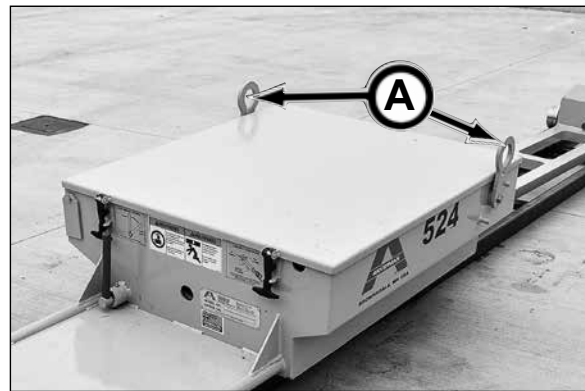

4. Open battery compartment cover. Lower the battery pack into the haul unit and connect the battery harness (B) with the contactor harness (C). Replace battery compartment cover (D).

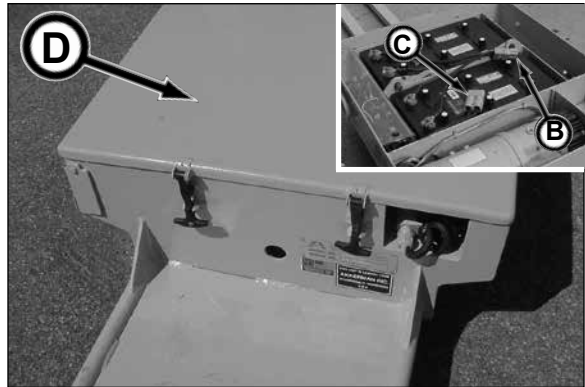

- . Lower the dirt bucket onto the haul unit rails.



## INSTALLING TRACK

1. Track sections are easily connected with a single bolt and wing nut. The first track section should be installed to the TBM.

Install additional track after the trailing pipe has been lowered on the jacking system base and mates with the leading pipe.

**NOTICE** Periodically inspect track bolts and wing nuts for tightness and damage. Retighten track bolts/wing nuts as necessary. If damaged, replace with new.

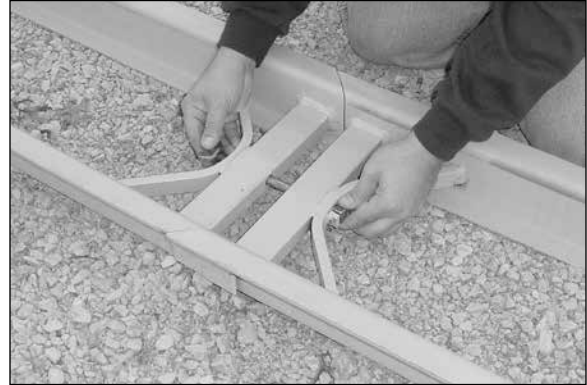

2. If track risers (A) are required, center the track risers under each track connection (B).

**NOTICE** Track risers are used to retain the track height from the TBM to the yoke for matching the centerline of the pipe.

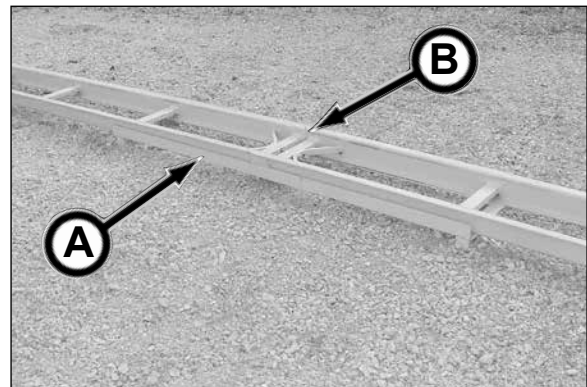

3. The sliding track will slide in and out with the movement of the intermediate jacking station (IJS). Be sure no track joints are in the IJS.

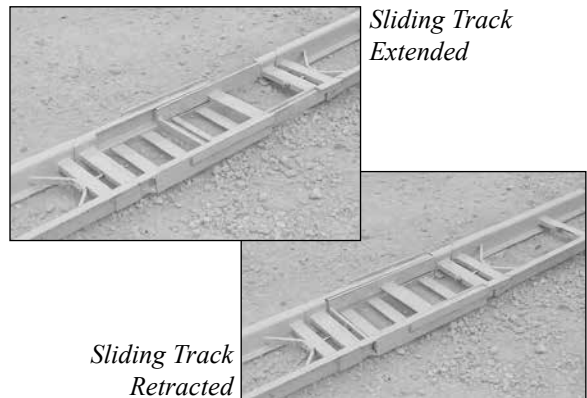

4. The track adapters are used when connecting the new Z track with the old style track.



## ADJUST STEERING HAUL UNIT FOR STEERING (F25865F)

If using curved track, follow the directions below to achieve up to 3.5° in each direction.

1. Loosen jam nuts (A).

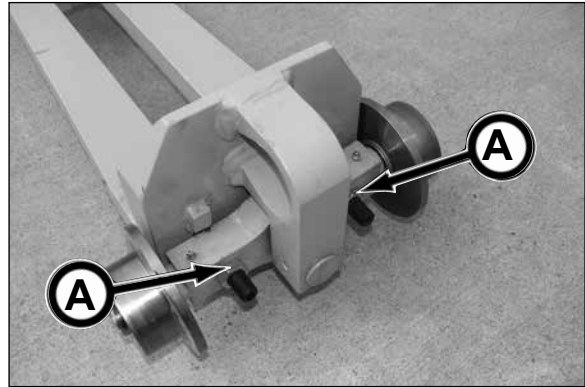

2. Adjust set screws (B) with 3/8" allen wrench as needed.

3. Retighten jam nuts (A).

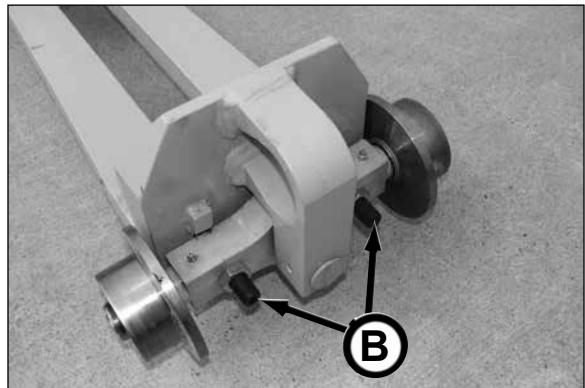

## **NOTES**

## OPERATING THE HAUL UNIT

**⚠ WARNING** Contacting tunnel wall and boring head components can cause severe injury or death. Keep all body parts on Haul Unit while Haul Unit is moving.



**⚠ WARNING** Keep Boring Head and tunnel well ventilated at all times.

Use an approved air analyzer to detect hazardous gases and oxygen content before and during tunnel operation.

If the levels exceed OSHA prescribed levels, leave tunnel immediately! Do not activate or deactivate any electrical or hydraulic devices, since any sparks can cause an explosion.

Gases must be removed before reentering tunnel. Do not use Haul Unit to evacuate the tunnel. Doing so may cause an explosion.

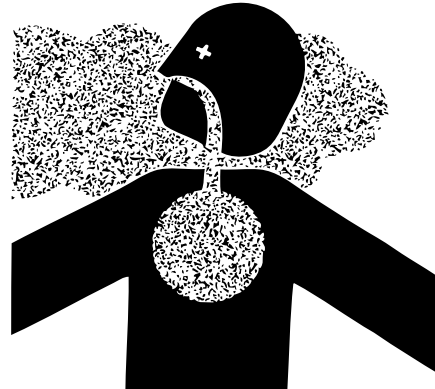

1. Mount the haul unit operator platform, so all body parts are on platform.
2. Clear all personnel from the bucket unloading area and pipeline travel area.

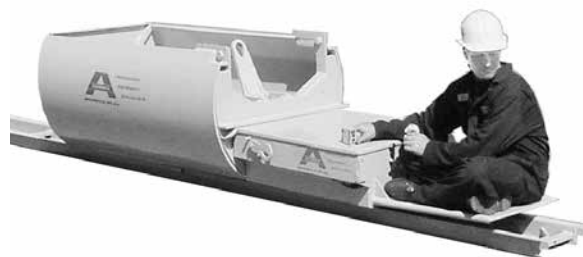

*(continued on next page)*

**NOTICE** The haul unit is equipped with a brake that will hold the unit until it is electrically released.

3. Release the brake by depressing the brake release switch (A).

**NOTICE** If switch “click” delay is present, switch will malfunction. The switch will need to be reset or replaced.

4. Start travel into the pipeline by holding the brake release switch down and depressing the IN tunnel switch (B or C depending on conventional or nonconventional operation).

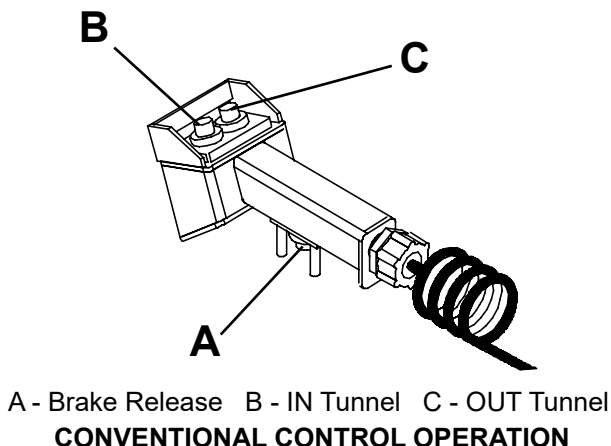

**NOTICE** In a conventional haul unit operation, the haul unit goes into the pipeline first, then the dirt bucket. In a nonconventional haul unit operation, the dirt bucket goes into the pipeline first, then the haul unit.

5. Release the IN tunnel switch to allow coasting of the haul unit.
6. Release the brake release switch to activate the brake. Forward momentum will carry the haul unit past the point where the brake is applied.

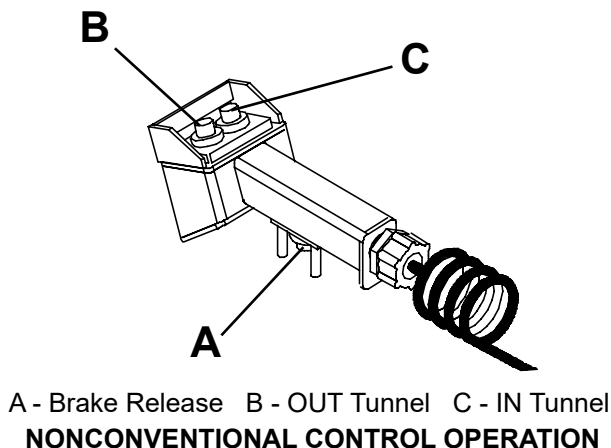

**NOTICE** (SN F10325F-86 & After) Use the hydraulic hand brake (D) as needed to stop the haul unit by pulling the brake lever towards the operator.

**NOTICE** A hand brake retrofit kit is available for haul units SN F10325F-85 & Before. Contact your Akkerman Aftermarket Support representative for more information.

7. Use the OUT tunnel switch (B or C depending on conventional or nonconventional operation) to move the haul unit out of the pipeline.

**NOTICE** A controlled method of moving the haul unit is called “inching.” The inching of the unit is accomplished by holding down the brake release switch and quickly depressing and releasing the travel switch. Continue this travel switch depress/release action until the unit coasts to the desired position. Release brake release switch.

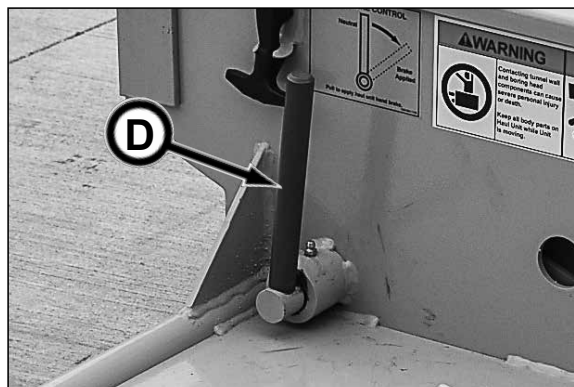

## USING THE DIRT BUCKET

1. With the dirt bucket lowered onto the haul unit's rails, lower the bucket lift eye.



**⚠ WARNING** Avoid contact with conveyor. Failure to do so could cause severe injury or death.

2. Move the haul unit into the tunnel. The dirt bucket must be positioned behind the conveyor to contain the spoil.



3. When the dirt bucket is full, move the haul unit/ dirt bucket out of the tunnel until the dirt bucket clears the tunnel wall to the unloading area.



4. Flip the bucket lift eye up.

**⚠ WARNING** Suspended loads may fall and cause severe personal injury or death. Do not enter area under or around a load.

5. With a crane or excavator, check for clearances and carefully lift dirt bucket out of unloading area and move to dumping site.



*(continued on next page)*

6. Unload dirt bucket. The dirt bucket is self-dumping when using a two-line crane or when attaching a stationary line.



7. After dirt bucket is empty, move the dirt bucket to the unloading area and lower onto haul unit rails.
8. Lower bucket lift eye.
9. Follow steps 2 through 8 until the tunnel is complete.



10. After tunnel is complete, flip the bucket eye up (see inset), and lift the dirt bucket out of shaft area.



## USING THE INSPECTION CART

**⚠ WARNING** Be sure no one is operating the haul unit while using the inspection cart. Severe injury can result if haul unit contacts personnel or inspection cart.

Use the inspection cart to transport tools and parts in the pipeline for repairs.

1. Place the inspection cart on the track.
2. Place tool box and/or parts on the cart.
3. Using your hands, slowly move the cart on the track.

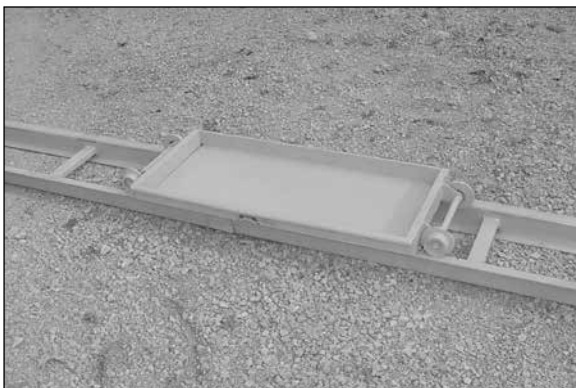

## RECHARGING THE BATTERY PACK

**⚠ WARNING** Batteries produce explosive gases. Wear eye protection and protective clothing during battery service. Keep sparks, flames, and cigarettes away from batteries.

If acid enters eye, IMMEDIATELY flush eye with running cold water for at least 15 minutes and get medical attention.

If battery acid contacts skin or clothing, wash immediately with soap and water.

Do not expose charger to rain or snow. Charge batteries only in a well ventilated area away from open flames and sparks.

The battery charger is a self-regulating charger. When the battery has reached its maximum state of charge, the circuitry will automatically turn the charger off.

The batteries can be recharged while the battery pack is in the haul unit or at the spare battery pack.

### RECHARGING AT HAUL UNIT

1. Slide charger plate UP.
2. Connect the charger DC output plug to charger plug on haul unit.
3. Before recharging battery, remove battery compartment cover to assure proper ventilation.
4. Check battery electrolyte level. Follow instructions from battery manufacturer.

If using the Lestronic II Battery Charger:

5a. Connect AC supply cord to a properly grounded single phase outlet of the proper voltage and frequency as specified on front of charger.

5b. The charger will start after a short delay as indicated by the transformer hum and the ammeter movement (A).

If using the Quick Charge Battery Charger:

5c. Plug the charger into AC power and flip the power switch ON (B).

5d. Flip the meter switch (C) to volts.

5e. As the battery becomes charged, the volts will continue to rise until the LED indicator (D) is green.

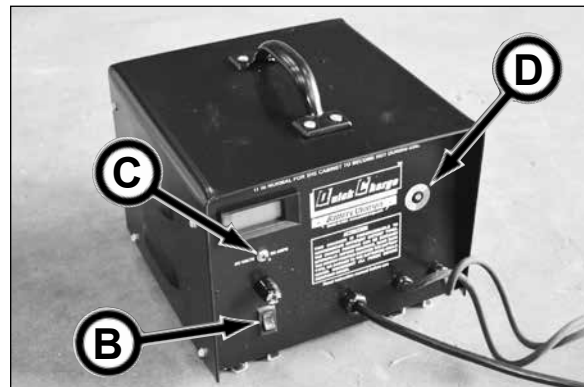
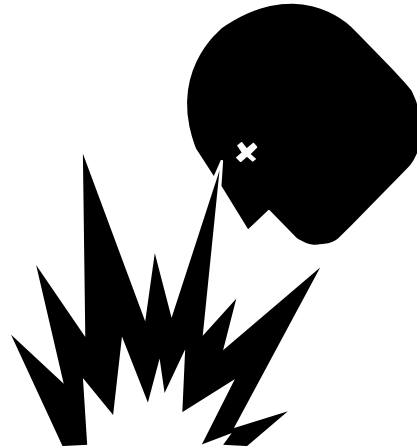

(continued on next page)

6. After properly charged, ALWAYS disconnect AC cord from its outlet first.
7. Secure battery compartment cover and disconnect DC output plug from charger plug.
8. Slide charger plate DOWN so the charger plug is fully covered.
9. Store battery charger in a clean, dry area.



### RECHARGING SPARE BATTERY PACK

1. Check battery electrolyte level. Follow instructions from battery manufacturer.
2. Connect the charger DC output plug to battery harness plug.



If using the Lestronic II Battery Charger:

- 3a. Connect AC supply cord to a properly grounded single phase outlet of the proper voltage and frequency as specified on front of charger.

- 3b. The charger will start after a short delay as indicated by the transformer hum and the ammeter movement (A).



If using the Quick Charge Battery Charger:

- 3c. Plug the charger into AC power and flip the power switch ON (B).

- 3d. Flip the meter switch (C) to volts.

- 3e. As the battery becomes charged, the volts will continue to rise until the LED indicator (D) is green.

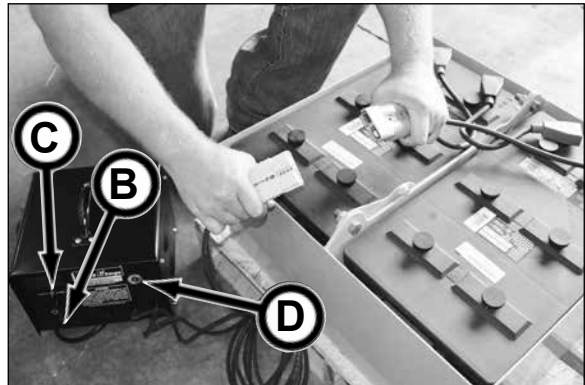

4. After properly charged, ALWAYS disconnect AC cord from the outlet first.
5. Disconnect DC output plug from battery harness plug.
6. Store battery charger in a clean, dry area.

For more information, refer to your Battery Charger Operation Manual.

*Operation*

## **NOTES**

# Transporting

---

## TRANSPORTING GUIDELINES

1. Know the local, state, and federal transportation regulations.
2. Obtain required permits for transporting.
3. Remove any obstacles from the trailer floor.
4. Load and unload on level ground.
5. Place haul unit controller inside the battery compartment prior to shipping to prevent damage to controller.
6. It is best to lower haul unit onto blocks on trailer floor. This will make it easier when using fork lift to remove haul unit from trailer.
7. Do not use chain to fasten haul unit to trailer floor. Use straps to prevent damage to haul unit.
8. Lower spare battery pack into dirt bucket for transporting.
9. Be careful if using chains to secure dirt bucket. Travel vibration can cause chain hammering. If possible, use straps to secure dirt bucket to trailer floor.

*Transporting*

## **NOTES**

# Lubricants

## NOTICE

Use of inferior lubricants can affect the efficient performance of your Haul Unit. Always use high quality lubricants as specified in this section. Refer to the Periodic Maintenance section for proper lubrication quantity, maintenance intervals, and procedures.

## GEAR REDUCER GEAR BOX LUBRICANT

The gear reducer gear box is filled with Mobil SHC 630 Synthetic Bearing and Gear Oil.

Use Mobil SHC 630 or equivalent when adding or changing lubricant.

## NOTICE

The Mobil SHC 630 Synthetic Bearing and Gear oil is a synthetic oil specifically designed for this application. If you change to a different oil, use a reputable oil supplier to meet or exceed the Mobil SHC 630 oil specification. Do not mix oil manufacturers or grades.

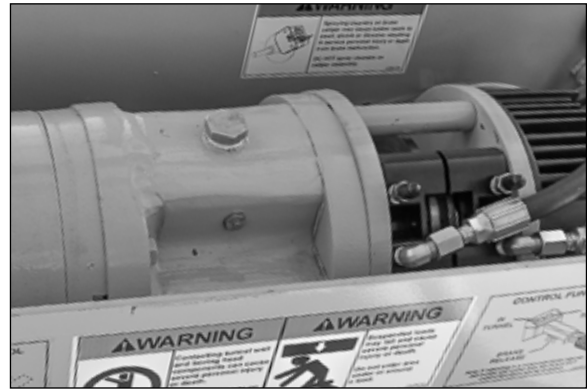

## HYDRAULIC BRAKE FLUID (SN F10325F-86 & AFTER)

The master cylinder (A) is filled with a DOT 3 brake fluid.

Use ONLY a DOT 3 brake fluid when adding or changing fluid.

## NOTICE

Never mix different manufacturer's brake fluids since the fluids may be incompatible resulting in brake failure.

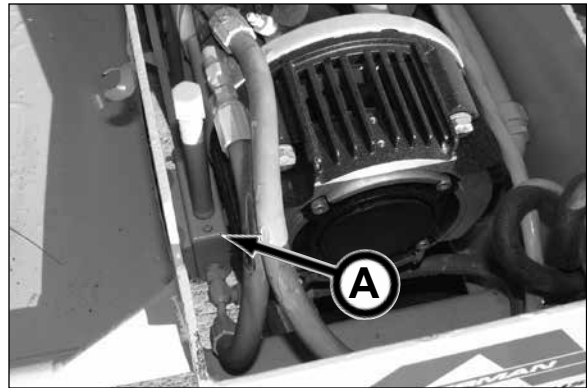

## GREASE

The lubrication points are greased with Mobilgrease® XHP222 Premium Lubricating Grease.

The XHP222 grease is a multi-purpose, high performance, high temperature, lithium grease.

Use Mobilgrease® XHP222 Premium Lubricating Grease or equivalent when lubricating the lubrication points.



---

## STORING LUBRICANTS

Your equipment can operate at maximum performance only if clean lubricants are used. Use clean containers to handle all lubricants.

Lubricants should be stored in an area protected from dust, moisture, and other contaminants.

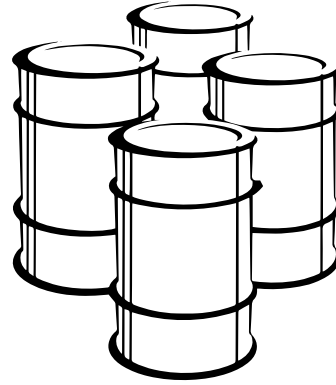

# Periodic Maintenance

**⚠ WARNING** Review the Safety section in this manual before performing maintenance. Failure to do so, could cause severe injury or death.

The requirements for lubrication and maintenance are shown on the maintenance charts in this section. Intervals of maintenance are based on normal operating conditions. If operating under more difficult conditions, use a shorter time interval between maintenance.

---

## LOCKOUT TAGOUT POWER BEFORE SERVICING

**⚠ WARNING** Severe personal injury or death can result from unexpected haul unit startup or machine movement.

LOCKOUT TAGOUT power before attempting to make repairs or adjustments to this equipment, unless otherwise indicated. Proper lockout tagout will prevent accidents and save lives. Performing lockout tagout will also prevent the equipment from moving unexpectedly.

1. Disconnect battery pack connector from harness connector.



2. Remove battery pack from the haul unit to prevent unintentional connecting of power.

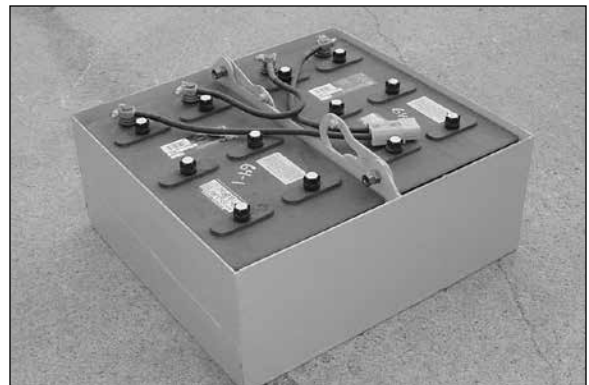

## MAINTENANCE CHARTS

Use the item number in the chart to refer to the detailed maintenance procedures later in this section.

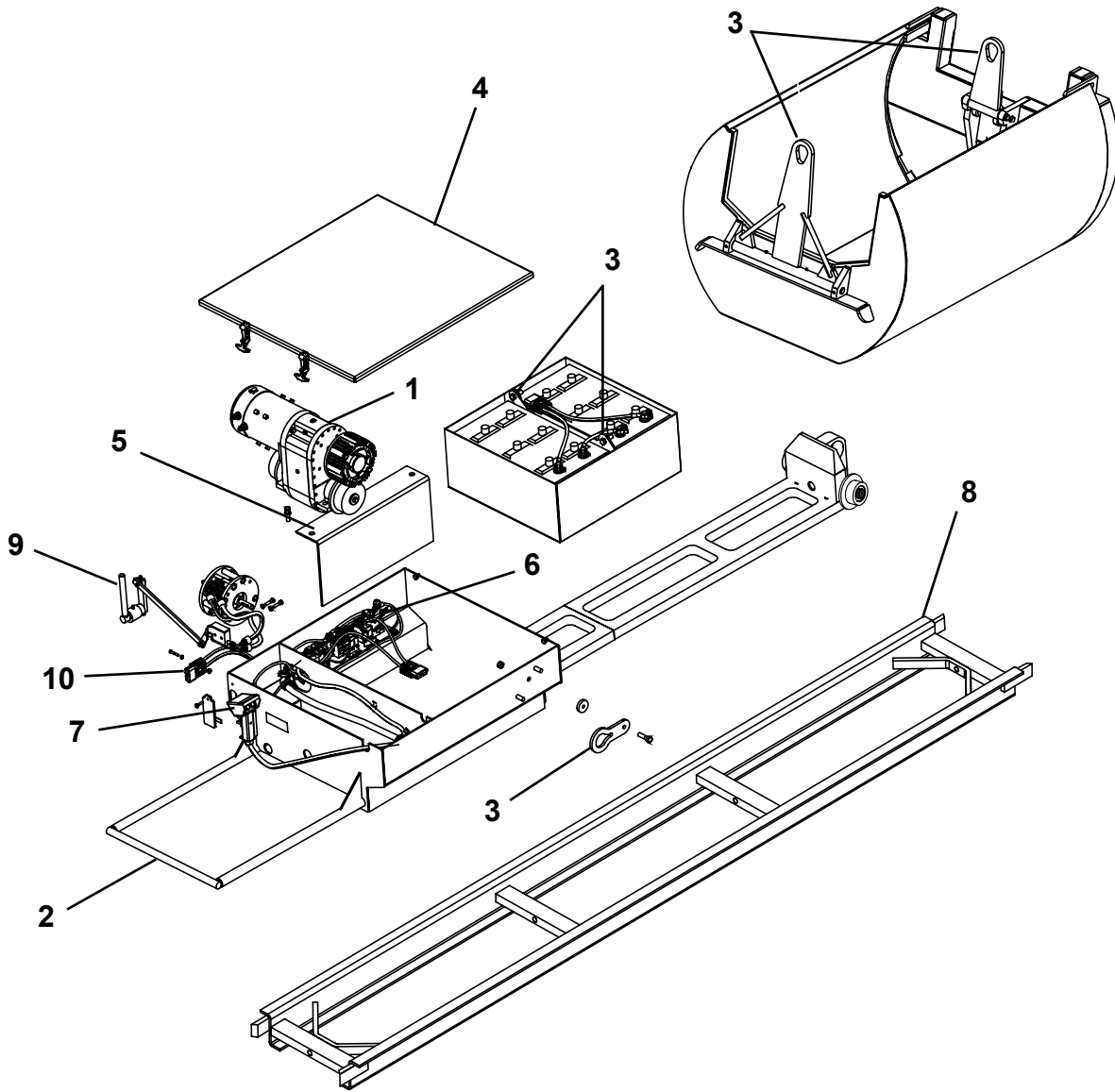

### DAILY OR EVERY 10 HOURS OF OPERATION OR SHIFT CHANGE

ITEM	COMPONENT	SERVICE	REQUIREMENT	MATERIAL
1.	Gear Reducer	Inspect For Leaks		
2.	Operator Platform	Clean & Inspect	If damaged, repair or replace.	
3.	Lifting Eyes	Inspect Pins & Hardware	If damaged, repair or replace.	
4.	Battery Compartmt Cover	Inspect	If damaged, repair or replace.	
5.	Contactor Shield	Inspect	If damaged, replace with new.	
6.	Contactors	Clean	Remove dirt and moisture.	Contact Cleaner
7.	Controller	Clean & Test	If switch delay present, repair or replace.	
8.	Track	Inspect	If damaged, repair or replace.	
9.	Brakes	Test Operation		
10.	Brake Fluid	Check Fluid Level	Fill to plug level.	DOT 3 Brk. Fluid

Periodic Maintenance Chart - Weekly or Every 50 Hours of Operation

Use the item number in the chart to refer to the detailed maintenance procedures later in this section.

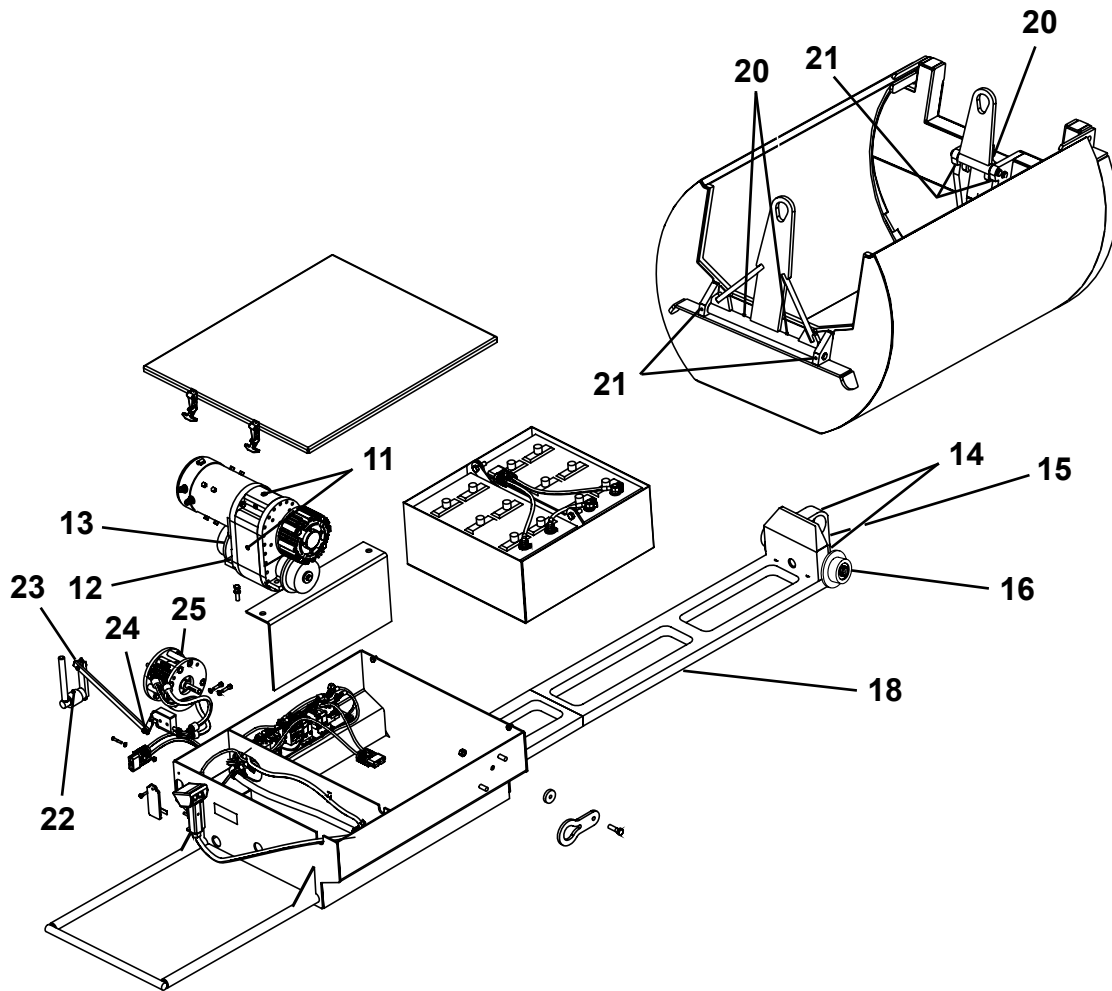

**WEEKLY OR EVERY 50 HOURS OF OPERATION**

ITEM	COMPONENT	SERVICE	REQUIREMENT	MATERIAL
11.	Gear Reducer	Check Oil Level	Fill to check plug.	Mobil SHC 630
12.	Gear Reducer	Check Mounting Bolts	Tighten to 50 ft-lb. (68 N·m)	Torque Wrench
13.	Gear Reducer	Check Whls./axle Shaft Seals	If leakage, replace with new.	
14.	Idler Wheel Brgs.	Lubricate (2)	Lubricate until grease is forced out.	Mobil XHP222
15.	Idler Axle Pivot Pin	Lubricate (1)	Lubricate until grease is forced out.	Mobil XHP222
16.	Idler Assembly	Inspect Wheels & Bearings	If damaged, replace with new.	
17.	Idler & Drive Wheels	Check Bolt Tightness	If damaged, replace with new.	
18.	Frame Rails	Inspect	If damaged, contact factory.	
19.*	Lock Pin (360/420)	Lubricate	Lubricate until grease is forced out.	Mobil XHP222
20.	Lifting Eye/Bar Hinge	Lubricate**	Lubricate until grease is forced out.	Mobil XHP222
21.	Lifting Eye/Hinge Pin	Check Set Screw (4 places)	Tighten	
22.	Hyd. Brake Lever	Lubricate	Lubricate until grease is forced out.	Mobil XHP222
23.	Brake Pivot Linkage	Lubricate	Lubricate until grease is forced out.	Mobil XHP222
24.	Brake Linkage	Lubricate	Spray	Silicone Lubricant
25.	Hydraulic Brake	Inspect	Repair or replace as needed.	

\* Not Shown

\*\* 360/420 - 2 lubrication point; 480/540/600 - 3 lubrication points

Periodic Maintenance Chart - Monthly or Every 250 Hours of Operation

Use the item number in the chart to refer to the detailed maintenance procedures later in this section.

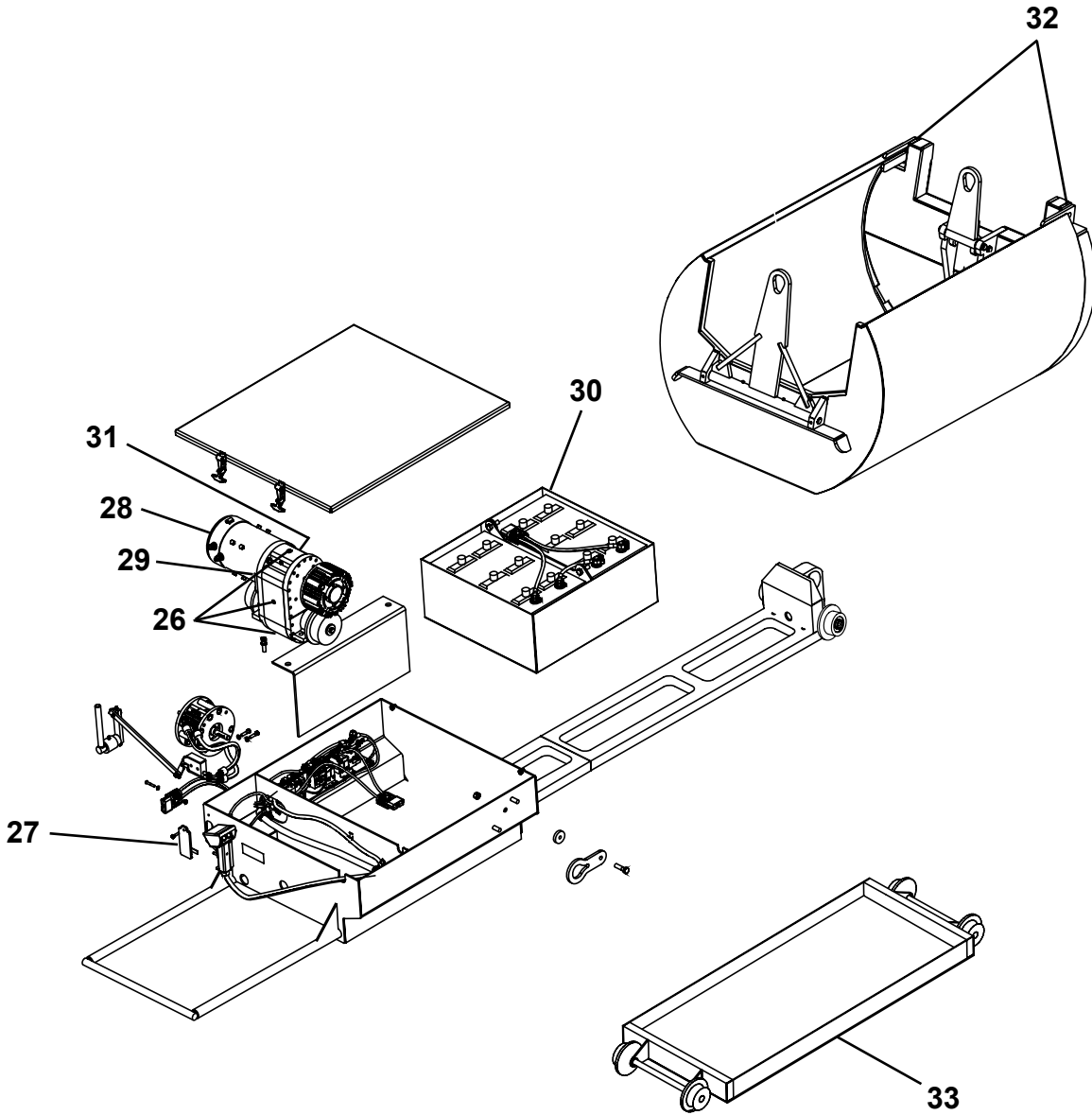

**MONTHLY OR EVERY 250 HOURS OF OPERATION**

ITEM	COMPONENT	SERVICE	REQUIREMENT	MATERIAL
26.	Gear Reducer Gear Box	Drain & Fill	1 qt. (0.9L)	Mobil SHC 630
27.	Charging Plug	Clean		Contact Cleaner
28.	Motor	Inspect & Clean Brushes		Torque Wrench
29.	Motor	Check Mounting Bolts	Tighten to 40 ft-lb. (54 N·m)	Baking Soda Solution
30.	Batteries	Inspect & Clean		
31.	Gear Reducer Relief	Inspect	If damaged, replace with new.	
32.	Bucket Door Pivot	Inspect	If damaged, replace with new.	
33.	Inspection Cart	Inspect Frame & Wheel Bearings	If damaged, repair or replace.	

## DAILY OR EVERY 10 HOURS OF OPERATION OR SHIFT CHANGE

### 1. INSPECT GEAR REDUCER

1. Remove battery compartment cover to gain access to gear reducer (A).
2. Visually check gear reducer for leaks. If any leaks are present, determine the cause and repair gear reducer before operating haul unit.
3. If necessary, add oil. See "11. Check Gear Reducer Gear Box Fluid Level" in the 50 hour check of this section for proper oil type and refilling procedure.
4. Before operating, secure battery compartment cover.

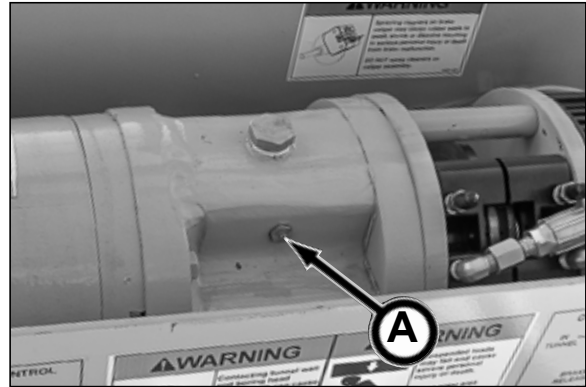

### 2. INSPECT OPERATOR PLATFORM

Clean and inspect operator platform (B) for cracks or other damage.

If cracks or damage are present, contact your Akkerman Aftermarket Support representative for authorized repair or replacement procedures.

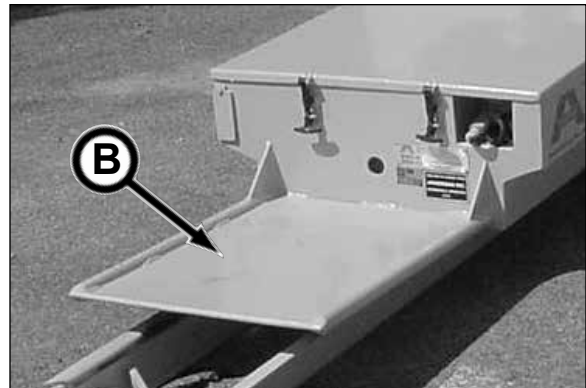

### 3. INSPECT HAUL UNIT, DIRT BUCKET & BATTERY PACK LIFTING EYES, PINS & HARDWARE

#### HAUL UNIT

Inspect haul unit lifting eyes (C) for cracks or other damage. Repair or replace before lifting.

Check hardware for damage. If damaged, replace with new.

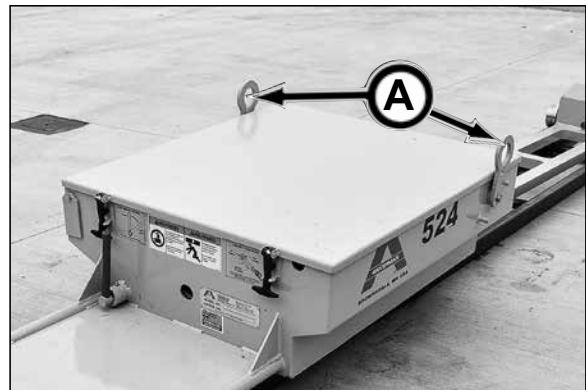

*Haul Unit Lifting Eyes*

#### DIRT BUCKET

Inspect dirt bucket lifting eyes (D) for cracks or other damage. Repair or replace before lifting.

Check pins and hardware (E) for damage. If damaged, replace with new.

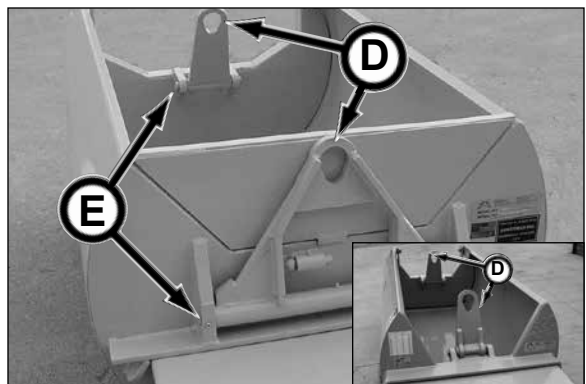

*Dirt Bucket Lifting Eyes*

*(continued on next page)*

#### BATTERY PACK

Inspect battery pack lifting eyes (A) for cracks or other damage. Repair or replace before lifting.

Check hardware for damage. If damaged, replace with new.

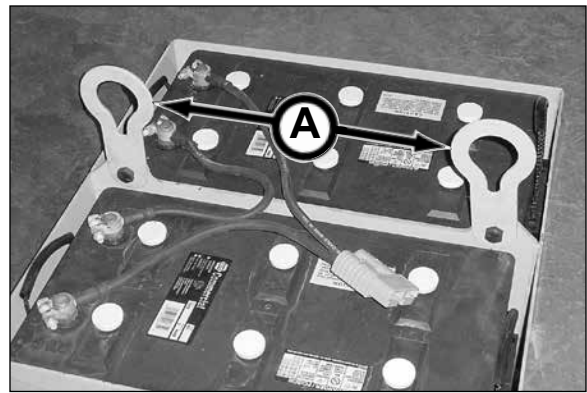

Battery Pack Lifting Eyes

#### 4. INSPECT BATTERY COMPARTMENT COVER

Inspect cover for cracks or other damage. Repair or replace as required.

Check to make sure the cover fasteners will securely hold cover to haul unit.



#### 5. INSPECT CONTACTOR SHIELD

Inspect shield for cracks or other damage. If damaged, replace with new.

The contactor shield must always be in place while operating.

#### NOTICE

The battery pack is shown in the haul unit for photographic purposes only. Use lockout tagout procedures during maintenance.

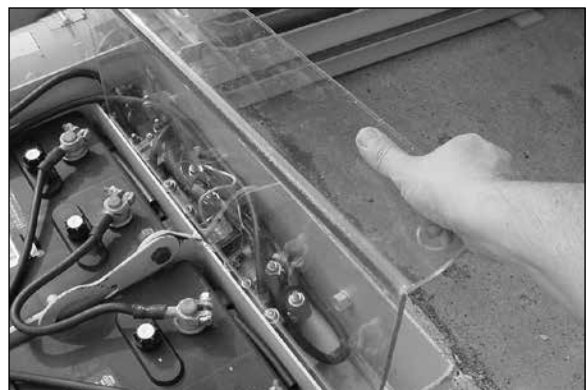

#### 6. CLEAN CONTACTORS

Clean contactors (B) with an approved contact cleaner to remove dirt and moisture.

**WARNING** Contact cleaner is EXTREMELY FLAMMABLE.

Replace contacts if they become sticky or pitted.

#### NOTICE

The battery pack is shown in the haul unit for photographic purposes only. Use lockout tagout procedures during maintenance.

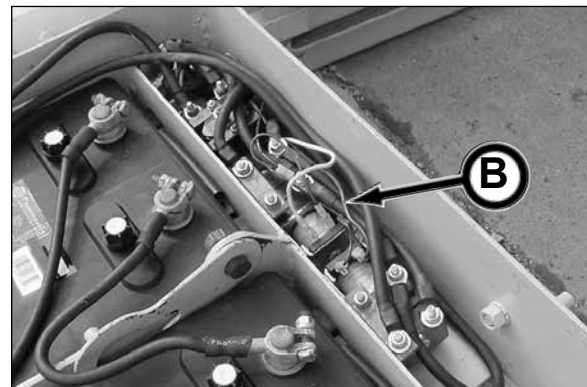

## 7. INSPECT CONTROLLER

1. Clean and inspect the controller, control cord, and switches for damage.
2. Test the controller functions for proper operation.

**NOTICE** The battery pack must be connected to perform this test.

If controller does not work properly, perform the following service:

- a. Completely tighten switch boot (A) to switch (B), then back off one revolution.
- b. Check for delay of switch "click."
- c. Retighten boot to switch until no switch "click" delay is present.
- d. Then apply Locktite to boot threads and install to switch plate (C).

**NOTICE** If switch "click" delay is present, switch will malfunction. The switch will need to be reset or replaced.

Discontinue use if operating mechanism becomes sticky or switches are inoperable. Repair or replace controller immediately.

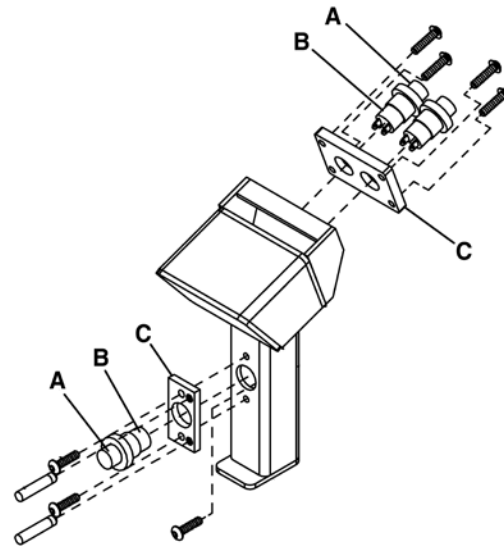
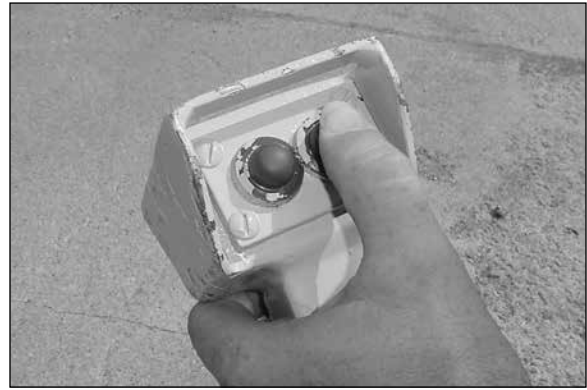

## 8. INSPECT TRACK

Check to be sure each track section is securely fastened.

Inspect track for cracks or other damage. Repair or replace as required.



## 9. TEST BRAKE OPERATION

(All Models) Electric Brake

The 524 Haul Unit is equipped with a brake that will hold the load until it is electrically released with the brake release switch.

Test the brake operation by depressing the brake release switch, propelling the haul unit and then release brake release switch. Once the switch is released, the haul unit should slow to a stop with its brake system. If not, the electric brake must be repaired before operating haul unit.



(SN 10325F-86 & After) Electric & Hydraulic Brakes  
Test the hydraulic brake operation by depressing the brake release switch, propelling the haul unit and then pulling the brake lever towards the operator.

If the haul unit fails to brake properly, check master cylinder brake fluid level and/or repair the brake system before operating haul unit into the pipeline.

**NOTICE** A hand brake retrofit kit is available for haul units SN F10325F-85 & Before. Contact your Akkerman Aftermarket Support representative for more information.



## 10. CHECK MASTER CYLINDER BRAKE FLUID LEVEL (SN F10325F-86 & AFTER)

1. With the haul unit on a level surface, remove battery compartment cover to gain access to the master cylinder reservoir (A).
2. Clean area around the master cylinder reservoir.
3. Remove cap (B) or plug on master cylinder reservoir. The brake fluid level should be 1/8 in. from fill neck.

If needed, fill reservoir ONLY with new brake fluid that meets or exceeds DOT 3 specifications.

4. Replace cap or plug.

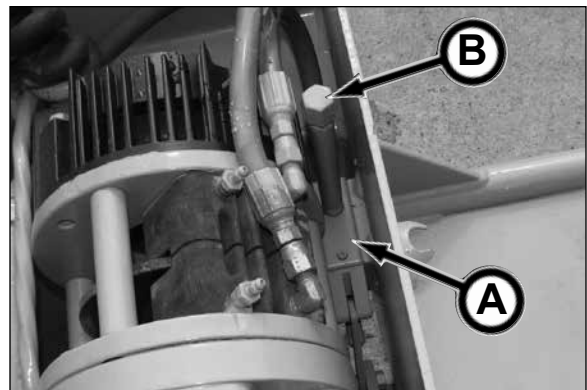

## WEEKLY OR EVERY 50 HOURS OF OPERATION

### 11. CHECK GEAR REDUCER GEAR BOX FLUID LEVEL

1. With haul unit on level ground, open battery compartment cover to gain access to the gear reducer. Clean area around check plug (A) and fill plug (B).
2. Remove check plug.
3. If fluid is not at plug level, remove fill plug and add Mobil SHC 630 or equivalent until oil is level with check plug.

#### NOTICE

The Mobil SHC 630 Synthetic Bearing and Gear oil is a synthetic oil specifically designed for this application. If you change to a different oil, use a reputable oil supplier to meet or exceed the Mobil SHC 630 oil specification. Do not mix oil manufacturers or grades.

4. Replace check and fill plugs. Secure battery compartment cover.

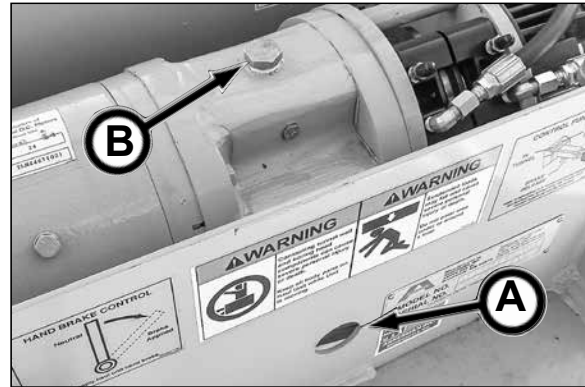

### 12. CHECK GEAR REDUCER MOUNTING HARDWARE TORQUE

Check four mounting bolts (C) for tightness. Tighten to 50 ft.lb. (68 N-m) torque.

If bolts are damaged or do not hold torque, replace with new.

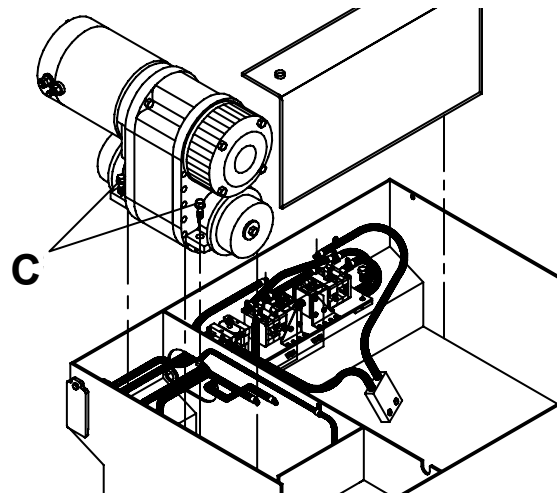

### 13. CHECK GEAR REDUCER WHEELS AND AXLE SEALS

Check wheels (D) for damage. If damaged, replace with new.

Check axle shaft seals (E) for leakage or damage. If seals leak or are damaged, replace with new.

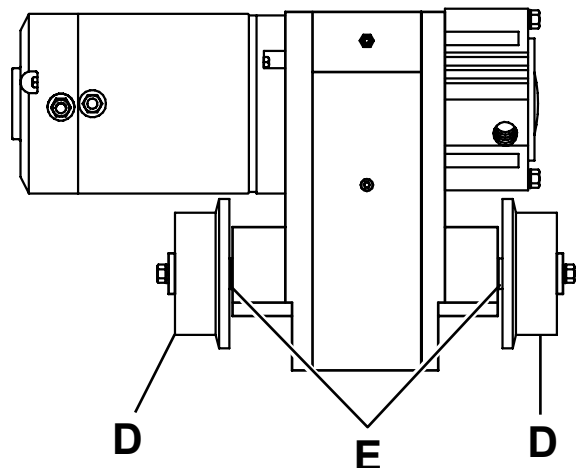

#### 14. LUBRICATE IDLER WHEEL BEARINGS

Lubricate the bearings (2 places) with Mobilgrease® XHP222 or equivalent until grease is forced out.

Lubricate more often in wet conditions.

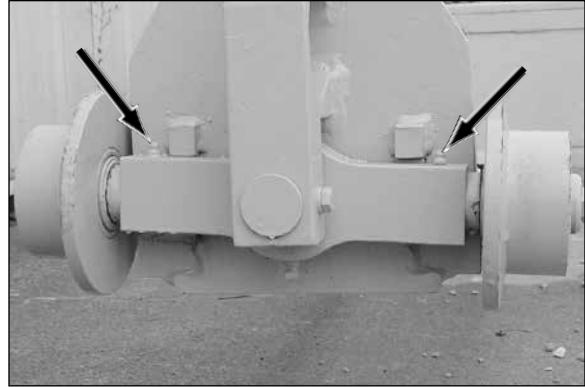

#### 15. LUBRICATE IDLER AXLE PIVOT PIN

Lubricate the pivot pin (A) with Mobilgrease® XHP222 or equivalent until grease is forced out.

Lubricate more often in wet conditions.

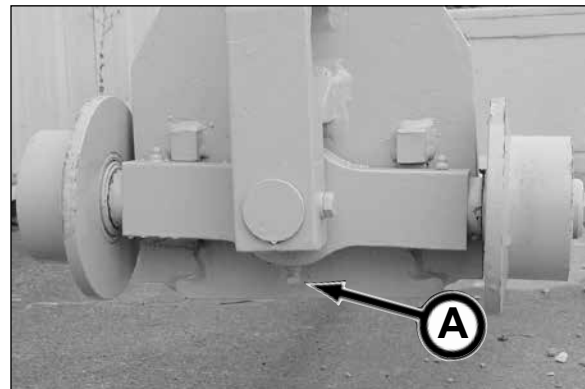

#### 16. INSPECT IDLER ASSEMBLY WHEELS & BEARINGS

Inspect idler wheels and bearings for damage. If damaged, replace with new.



### 17. CHECK IDLER & DRIVE WHEELS

Check idler wheel and drive wheel hardware for tightness.

The idler wheel hardware (A) must be tightened to 106 ft-lb (144 N·m) torque.

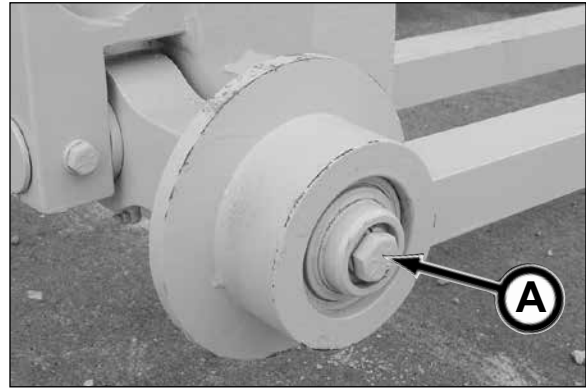

The drive wheel hardware (B) must be tightened to 43.6 ft-lb (59 N·m) torque.

If wheels or hardware are damaged, replace with new.

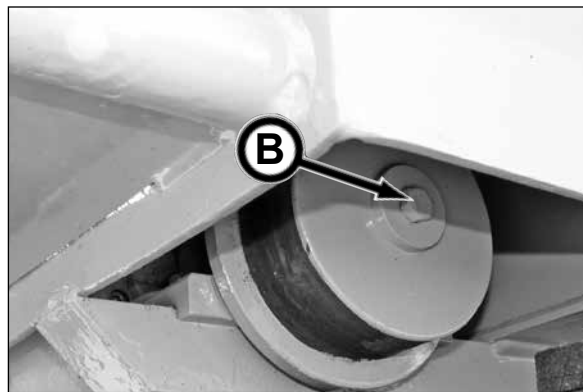

### 18. INSPECT HAUL UNIT FRAME RAILS

Inspect frame rails (C) for cracks or if no arch exists.

Contact your Akkerman Aftermarket Support representative if cracks or no arch are present.

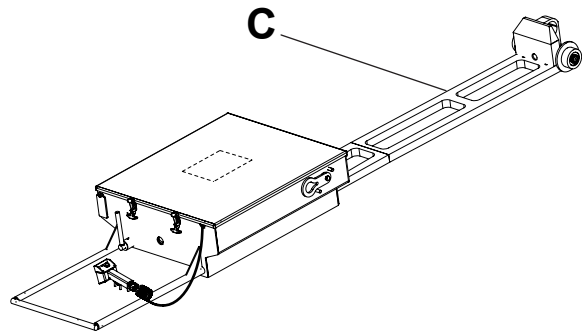

### 19. LUBRICATE DIRT BUCKET LOCK PIN (Earlier 360 & 420 Models only)

Lubricate lock pin (D) with Mobilgrease® XHP222 or equivalent until grease is forced out.

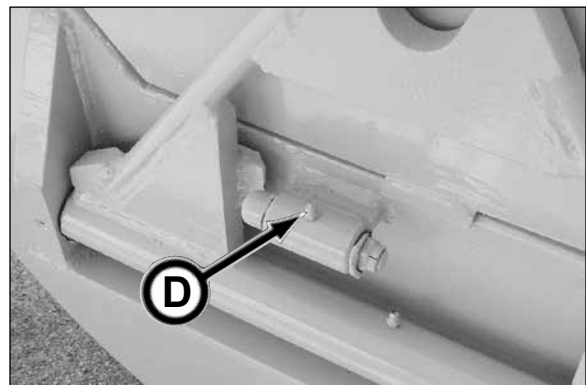

**20. LUBRICATE DIRT BUCKET LIFTING EYES  
& LIFTING EYE BAR HINGES**

Lubricate lifting eyes (A) with Mobilgrease® XHP222 or equivalent until grease is forced out.

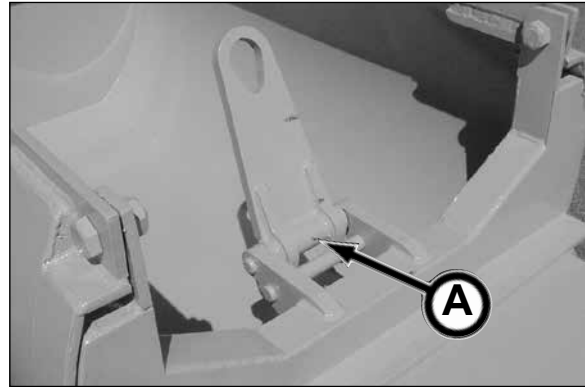

MODEL 360 & 420 DIRT BUCKETS  
(Earlier Models)  
Lubricate lifting eye bar hinge (B) with Mobilgrease® XHP222 or equivalent until grease is forced out.

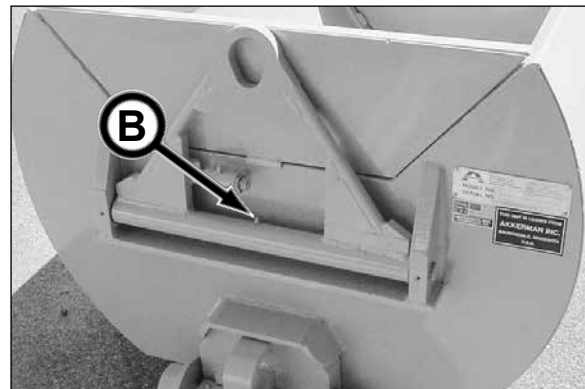

MODEL 480, 540, & 600 DIRT BUCKETS  
Lubricate lifting eye bar hinge (C) (2 places) with Mobilgrease® XHP222 or equivalent until grease is forced out.

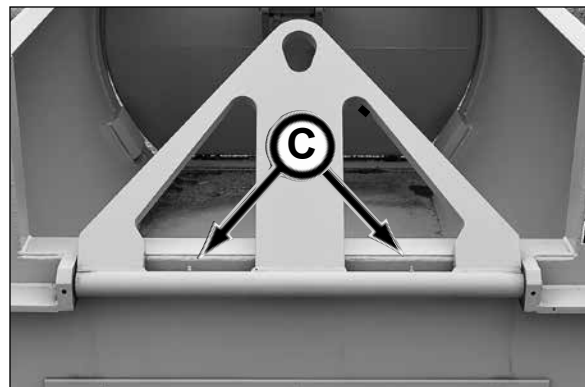

## 21. CHECK BUCKET LIFT BAR HINGE PIN & LIFTING EYE SET SCREWS

Tighten set screws (A) if loose. If set screws are damaged or will not hold, replace with new.

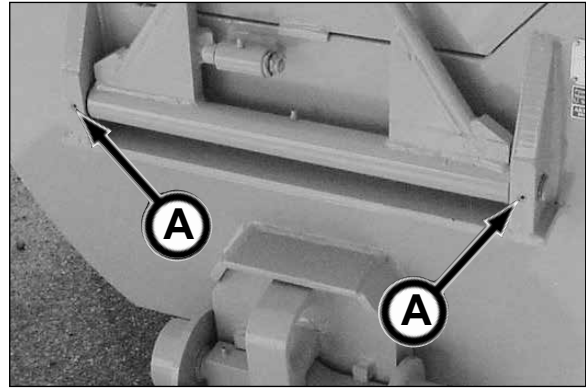

*Lift Bar Hinge Pin Set Screws*

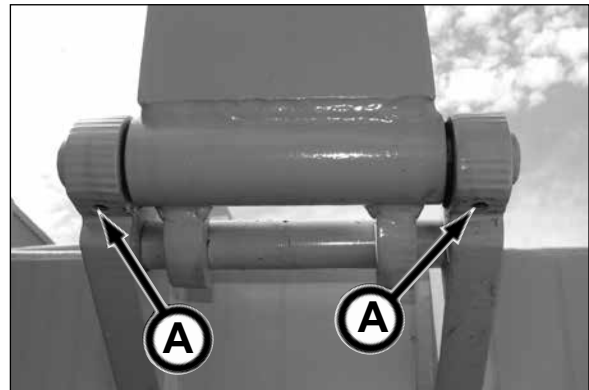

*Lifting Eye Set Screws*

## 22. LUBRICATE HYDRAULIC BRAKE LEVER

Lubricate brake lever (B) with Mobilgrease® XHP222 or equivalent until grease is forced out.

Lubricate more often in wet conditions.

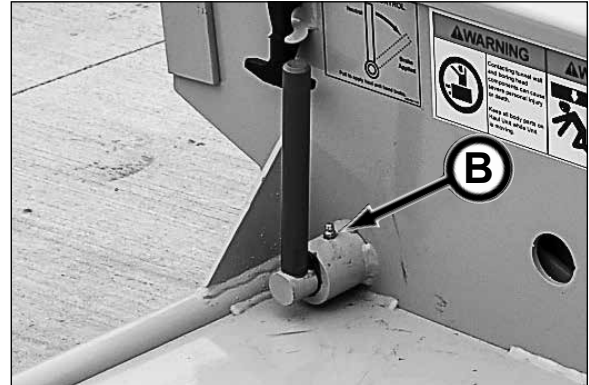

## 23. LUBRICATE HYDRAULIC BRAKE PIVOT LINKAGE

Lubricate pivot linkage (C) with Mobilgrease® XHP222 or equivalent until grease is forced out.

Lubricate more often in wet conditions.

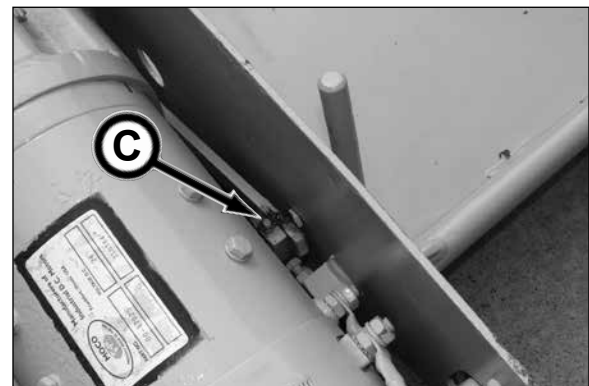

## 24. LUBRICATE HYDRAULIC BRAKE LINKAGE

Lubricate linkage (A) with an aerosol silicone lubricant.

**⚠ WARNING** DO NOT ALLOW ANY SPRAY LUBRICANT OR SPRAY VAPOR TO CONTACT THE BRAKE ASSEMBLY. DOING SO COULD CAUSE THE BRAKE TO MALFUNCTION AND CAUSE SERIOUS PERSONAL INJURY OR DEATH.

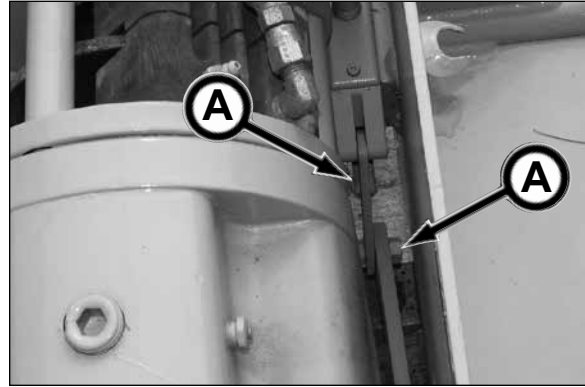

## 25. INSPECT HYDRAULIC BRAKE

**⚠ WARNING** Spraying cleaners on brake caliper may cause rubber seals to swell, shrink or dissolve resulting in serious personal injury or death from brake malfunction. Do not use spray cleaners on caliper assembly.

Inspect the hydraulic brake for any of the following conditions:

- build up on brake rotor
- leaking brake fluid
- build up of foreign matter in brake area
- spongy brake
- brake linkage binding
- damaged brake line
- any other unusual conditions

If any of these conditions occur, have your brake repaired IMMEDIATELY by a qualified brake technician.

**⚠ WARNING** If any of these conditions exist, do not operate haul unit until the brake has been repaired, including the bleeding of the brake (bleeding brake procedure follows below). Failure to do so could cause severe injury or death.

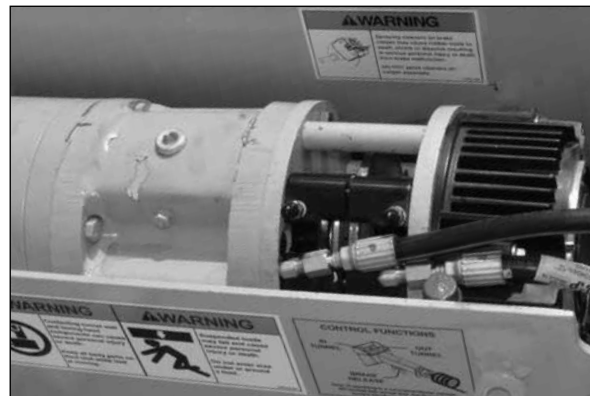

### **Bleeding the Hydraulic Brake**

1. Make sure the master cylinder (B) is filled with DOT 3 brake fluid.

**NOTICE** The master cylinder may require refilling during the bleeding procedure.

2. Attach one end of a transparent hose to a bleed screw (C) on one of the calipers. Route the other end of hose into the master cylinder reservoir.
3. Pump brake lever until there is a resistance.
4. Apply pressure on lever and loosen bleed screw with hose attached.
5. When brake lever is fully depressed, tighten bleed screw.
6. Release brake lever.
7. Repeat steps 3 through 6 until transparent hose is free of air bubbles.
8. Remove transparent hose.
9. Recheck master cylinder fluid level. Use only DOT 3 fluid.
10. Attach transparent hose to other bleed screw (D) and repeat steps 2 through 9.

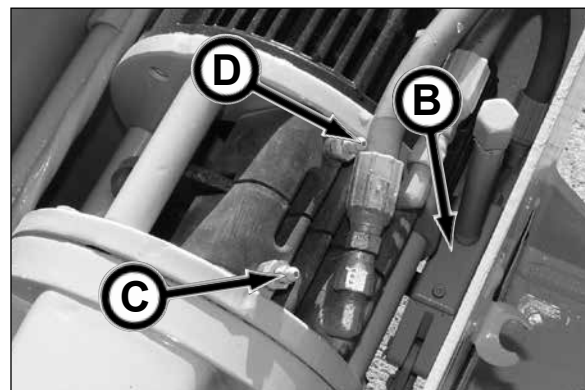

## MONTHLY OR EVERY 250 HOURS OF OPERATION

### 26. DRAIN & FILL GEAR REDUCER

1. With haul unit on level ground, clean area around fill, check, and drain plugs.
2. Remove drain plug and empty fluid into a proper sized catch pan. Dispose of fluid properly.
3. Inspect drain plug for metal particles. If particles are present, contact your Akkerman Aftermarket Support representative for gear reducer preventive maintenance procedures
3. Replace drain plug.
4. Remove fill plug (A) and add Mobil SHC 630 Synthetic Bearing and Gear Oil or equivalent.

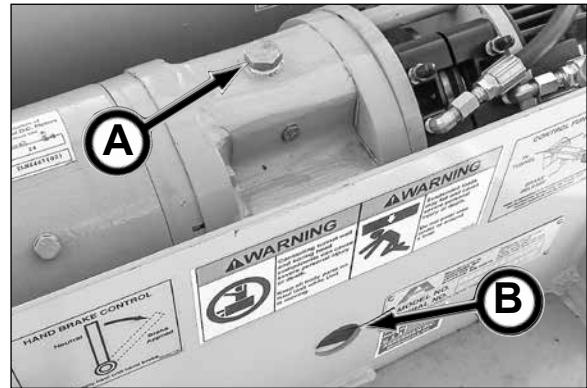

**NOTICE** The Mobil SHC 630 Synthetic Bearing and Gear oil is a synthetic oil specifically designed for this application. If you change to a different oil, use a reputable oil supplier to meet or exceed the Mobil SHC 630 oil specification. Do not mix oil manufacturers or grades.

The fluid should be level with check plug (B).

5. Place a small amount of pipe sealant on plug threads.
6. Replace check and fill plugs.

### 27. CLEAN CHARGING PLUG

Clean charging plug.

(If equipped) Check magnetic strip, behind charger plate, and clean as necessary.



### 28. INSPECT & CLEAN MOTOR BRUSHES

Remove motor covers (A) to inspect brushes. If damaged, replace with new.

Clean brushes with contact cleaner.

Reinstall covers before using haul unit.

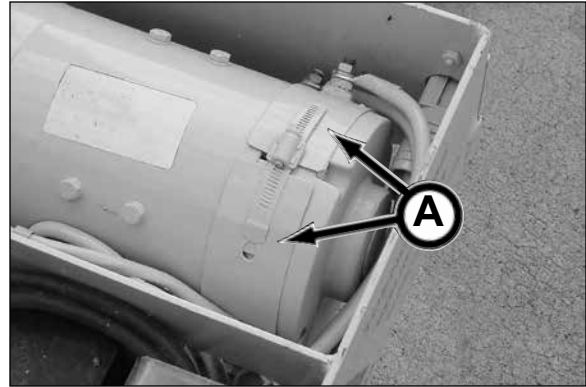

### 29. CHECK MOTOR HARDWARE

Check four motor mounting bolts (B). Retighten to 40 ft-lb. (54 N·m) torque.

If bolts are damaged or will not hold torque, replace with new.

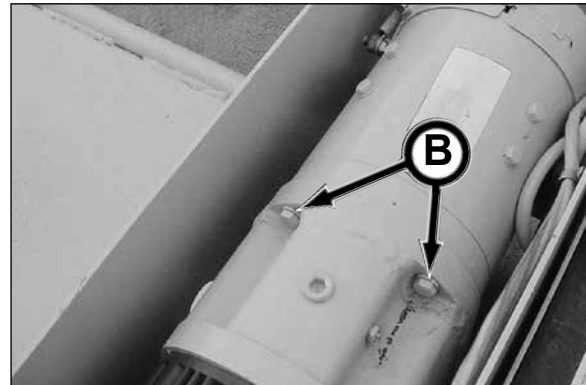

*Upper Motor Mounting Bolts*

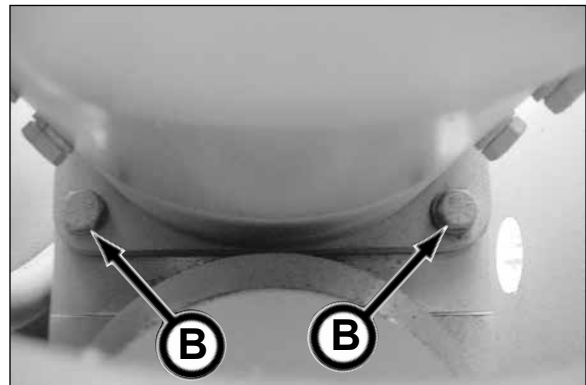

*Lower Motor Mounting Bolts*

### 30. PERFORM BATTERY MAINTENANCE

**⚠ WARNING** Batteries produce explosive gases. Wear eye protection and protective clothing during battery service. Keep sparks, flames, and cigarettes away from batteries. Charge batteries only in a well ventilated area.

If acid enters eye, IMMEDIATELY flush eye with running cold water for at least 15 minutes and get medical attention.

If battery acid contacts skin or clothing, wash immediately with soap and water.

If battery acid is inhaled, move to fresh air immediately. If breathing is difficult, administer oxygen.

If battery acid is ingested, give large quantities of water. DO NOT induce vomiting. Get medical attention immediately.



**NOTICE** For more information on battery maintenance, contact the battery manufacturer.

1. Clean terminal posts and cable connections with a wire brush. Coat the terminals with petroleum jelly to prevent corrosion. Never paint the terminal posts.
2. Check electrolyte level. Fill each cell with clean, distilled water to the bottom of the filler neck.
3. Check terminals and connections. Clean or replace if damaged.
4. Check cables for worn or frayed insulation. Replace cable or bolts if corroded.
5. Inspect the batteries for dirt or corrosion. Clean corrosion with baking soda (1/4 pound of baking soda added to a quart of water).
6. Inspect battery pack frame for cracks or damage. If damaged, repair or replace.
7. If necessary, charge the batteries. See Recharging the Battery Pack in the Operation section of this manual.

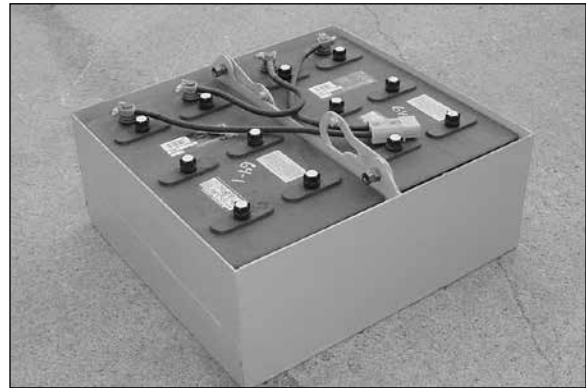

### **31. INSPECT GEAR REDUCER PRESSURE RELIEF**

Inspect pressure relief fitting on the gear reducer to make sure the relief plug can open. If relief vent plug is stuck, or does not pop back into fitting, replace with new.

A malfunctioning pressure relief fitting could result in gear reducer seal failure.



### **32. INSPECT DIRT BUCKET DOOR HARDWARE**

Inspect door pivot hardware for damage. If damaged, repair or replace. Do not lift until damaged hardware is repaired or replaced.

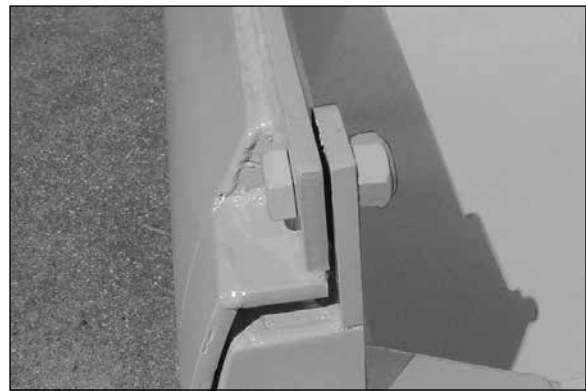

### **33. CHECK INSPECTION CART**

Check the inspection cart frame for cracks or damage. If damaged, repair or replace

Check the wheel bearings and hardware. If damaged replace with new.



# Storage

---

## PREPARING FOR STORAGE

1. Repair worn or damaged parts.
2. Wash all equipment thoroughly.
3. Grease haul unit and dirt bucket.
4. Drain and flush gear reducer. Add Mobil SHC 630 or equivalent to check plug level.
5. Remove battery pack and store in a cool, dry, well ventilated, place. Clean corrosion from cables and battery case. Charge battery packs. Refer to “30. Perform Battery Maintenance” in the Periodic Maintenance section.
6. Repaint equipment where necessary.

---

## REMOVING FROM STORAGE

1. Clean equipment thoroughly.
2. Check to make sure all decals including safety decals are clean and readable.
3. Check condition of wires and cables. Repair or replace as necessary.
4. Check gear reducer fluid level. Add oil as needed. Refer to Gear Reducer Gear Box Lubricant in Lubricants section.
5. Check for leaks. Repair or replace as necessary.
6. Charge battery packs. Refer to Recharging the Battery Pack in the Operation section.
7. Review this Operator’s Manual.

## **NOTES**

# Troubleshooting

<b>Problem</b>	<b>Cause</b>	<b>Solution</b>	
Haul Unit does not move.	Loose battery connections.	Secure battery harness and contactor harness.	
	Loose wires.	Repair or replace.	
	Dirty controller.	Clean controller.	
	Control cord damaged.	Replace controller cord.	
	Dead battery.		Recharge battery or replace with spare battery pack.
			Check battery electrolyte level.
			Dry contactors with contact cleaner*.
			Replace contactors.
			Keep contact shield in place.
			Control switch click delay is present.
Defective switch.			Replace switch.
	If Haul Unit still does not move, contact your Akkerman Aftermarket Support Representative.		
	Control switch click delay is present.	Readjust switch click.	
	Defective switch.	Replace switch.	
	Wet or damaged directional contacts.	Use contact cleaner* on contacts, motor armature, brushes, and brake assembly.	
Haul Unit moves in only one direction.	If Haul Unit continues to move in only one direction, contact your Akkerman Aftermarket Support Representative.		
	Control switch click delay is present.	Readjust switch click.	
	Defective switch.	Replace switch.	
Battery will not charge.	Blown charger fuse.	Replace fuse.	
	Dead battery.	Check/replace battery.	
	Battery charger malfunction.	Check/replace charger.	
Brake does not release.	Control switch click delay is present.	Readjust switch click.	
	Defective brake release switch.	Replace switch.	
	Brake polarity reversed.	Change red wire to + post.	
	If the brake still does not release, contact your Akkerman Aftermarket Support Representative.		
Brake does not engage after releasing brake release control.	Dirty or wet brake assembly.	Clean with contact cleaner*.	
	Brake wired incorrectly.	Repair brake wiring.	
	Brake assembly malfunction.	Replace brake.	

\* Contact cleaner is extremely flammable.

# HAUL UNIT ELECTRICAL SCHEMATIC

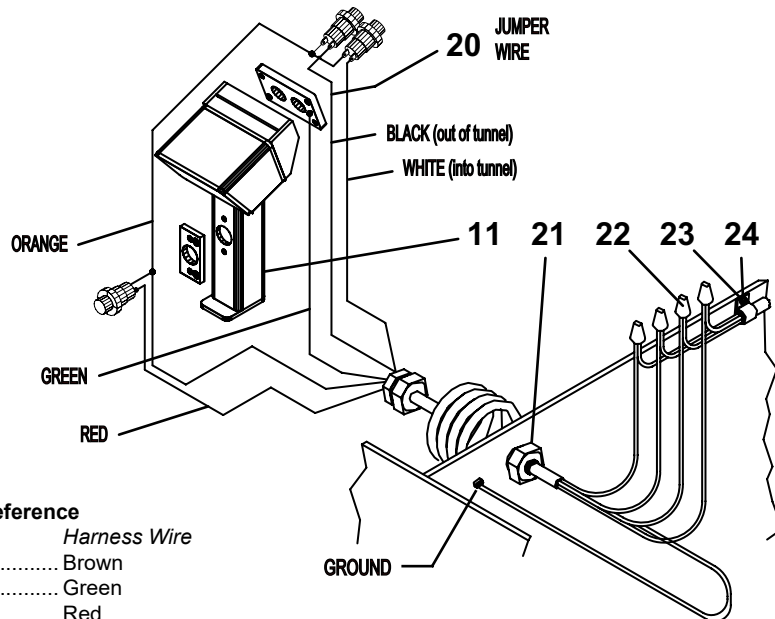
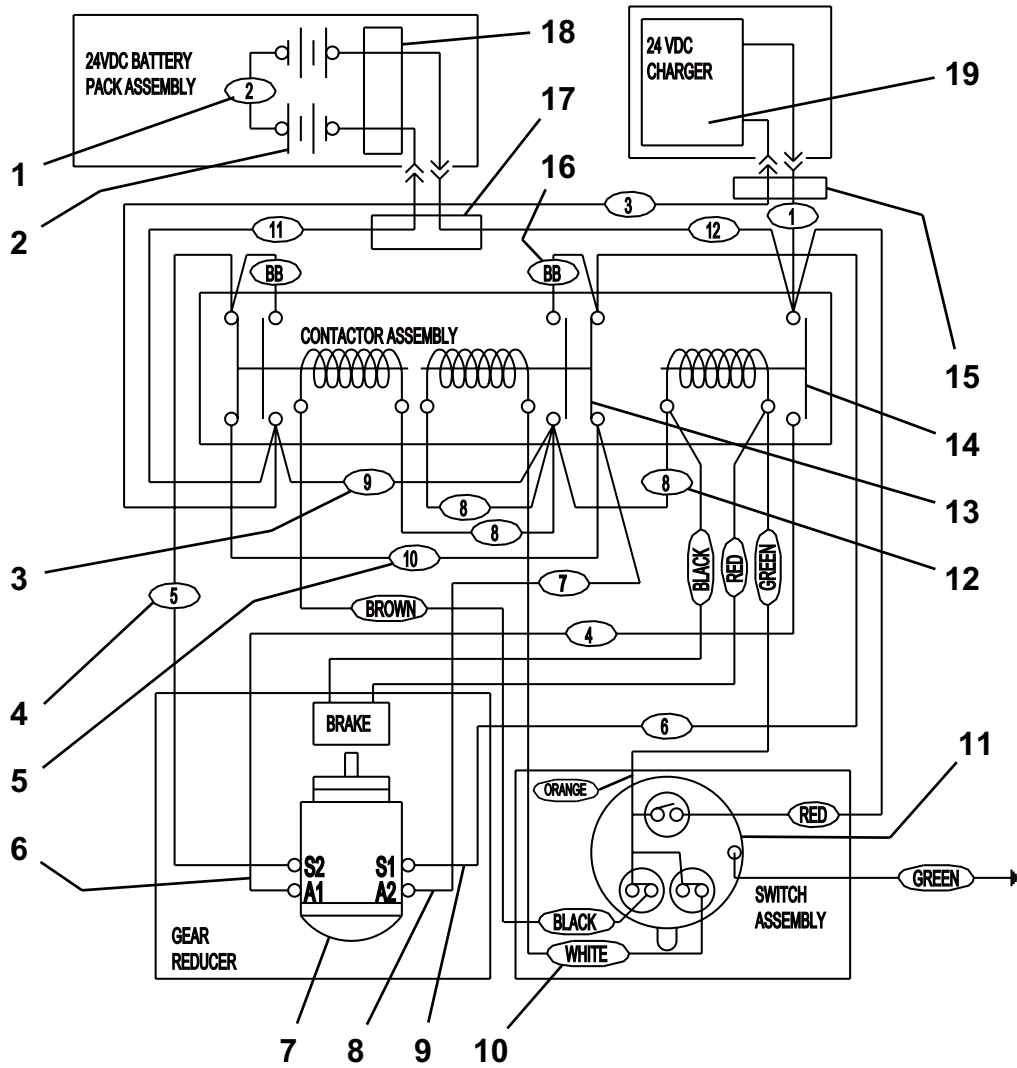

**Wire Color Reference**

Handle Wire	Harness Wire
Black.....	Brown
Orange.....	Green
Red.....	Red
White.....	Yellow
Green.....	Chassis Ground

# Specifications

## 524 HAUL UNIT

**Weight** (with battery pack) ..... 950 lbs. (431 kg)

**Length**

Standard ..... 128.5 in. (3264 mm)  
 Extended ..... 158.75 in. (4032 mm)

**Width** ..... 31 in. (787 mm)

**Wheel Base** ..... 93.2 in. (2367 mm)

**Drive Wheels** ..... 2

**Battery Pack**

Weight ..... 250 lbs. (113 kg)  
 Voltage ..... 24 VDC

**Electrical Horsepower** ..... 5

**Propel** ..... Forward, Reverse

**Speed\***

Miles per Hour ..... 0-4 mph (0-6.4 Km/h)  
 Feet per minute ..... 500 (152 m/min)

**Gear Reducer**

Ratio ..... 9:1  
 Oil Capacity ..... 1.8 qt. (1.7 L)  
 Oil Type ..... Mobil SHC 630 Synthetic  
 Bearing and Gear Oil

**Maximum Load Capacity**

GVW ..... 8,200 lbs. (3719 mm)

**Brake**

Electric (All) ..... Spring applied, electric release  
 Torque (static) ..... 10.5 ft.-lbs. (14 N-m)  
 Hydraulic (SN F10325F-86 & After)..... Caliper Disc

**Maximum Operating Grade**

Unloaded ..... 5%  
 Loaded ..... 2.5%

**Pipe (Tunnel) Size**

Minimum ..... 36 in. (914 mm)

**Track**

Track Gauge ..... 11.13 in. (283 mm)  
 Base ..... 14.13 in. (359 mm)  
 Height ..... 3.75 in. (95 mm)  
 Length ..... 8 ft. (2.4 m)

**DIRT BUCKETS\*\***

Model	360	48SC	420	480	540	600
<b>Height</b>						
in.	23	27.5	27.5	33	39	38
(mm)	(584)	(698)	(698)	(838)	(990)	(965)
<b>Width</b>						
in.	33	35.5	38	43	48	55
(mm)	(838)	(901)	(965)	(1092)	(1219)	(1397)
<b>Length</b>						
standard						
in.	60	60	60	60	60	60
(mm)	(1524)	(1524)	(1524)	(1524)	(1524)	(1524)
extended						
in.	90	90	90	90	90	90
(mm)	(2286)	(2286)	(2286)	(2286)	(2286)	(2286)
<b>Weight</b>						
standard						
lbs.	440	475	480	670	1000	1280
(kg)	(200)	(215)	(217)	(304)	(453)	(580)
extended						
lbs.	530	630	630	810	1180	1470
(kg)	(240)	(285)	(285)	(367)	(535)	(666)
<b>Capacity</b>						
standard						
cu. yd.	.9	1.0	1.1	1.5	1.9	2.3
(m <sup>3</sup> )	(.7)	(0.76)	(.84)	(1.1)	(1.5)	(1.8)
extended						
cu. yd.	1.3	1.6	1.7	2.3	2.9	3.5
(m <sup>3</sup> )	(1.0)	(1.2)	(1.3)	(1.8)	(2.2)	(2.7)

\* Contact your Akkerman Aftermarket Support Representative for speed ratings at various haul capacities.

\*\*Maximum load capacity for haul unit and dirt bucket many not exceed 8,200 lbs. (3719 mm).

## TORQUE CHART

Use these torque values as a guideline when tightening hardware unless otherwise specified in this manual.

Lubricated Coarse UNC Threads Grade 8 Fasteners			Lubricated Fine UNF Threads Grade 8 Fasteners		
Bolt Size	Torque		Bolt Size	Torque	
	ft. lbs.	(N·m)		ft. lbs.	(N·m)
1/4 - 20	10	(14)	1/4 - 28	11	(15)
5/16 - 18	20	(27)	5/16 - 24	22	(30)
3/8 - 16	35	(47)	3/8 - 24	39	(53)
7/16 - 14	56	(76)	7/16 - 20	62	(84)
1/2 - 13	85	(115)	1/2 - 20	96	(130)
9/16 - 12	123	(167)	9/16 - 18	137	(186)
5/8 - 11	170	(231)	5/8 - 18	192	(260)
3/4 - 10	301	(408)	3/4 - 16	336	(456)
7/8 - 9	450	(610)	7/8 - 14	500	(678)
1 - 8	680	(922)	1 - 12	740	(1003)
1-1/8 - 7	960	(1302)	1-1/8 - 12	1030	(1397)
1-1/4 - 7	1360	(1844)	1-1/4 - 12	1500	(2034)
1-1/2 - 6	2360	(3200)	1-1/2 - 12	2660	(3607)

# Identification Numbers

Model and serial numbers are required when ordering parts or requesting service information. Record your model and serial numbers below.

## HAUL UNIT (A)

Model Number \_\_\_\_\_

Serial Number \_\_\_\_\_

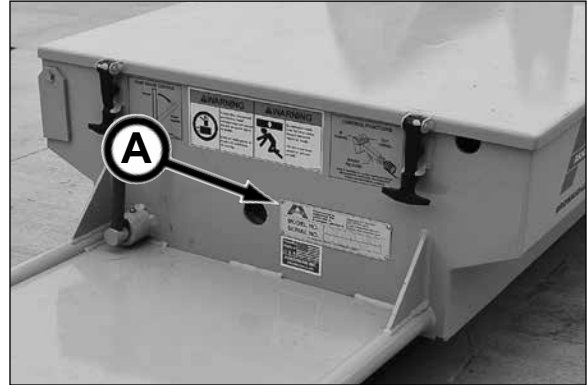

## DIRT BUCKET (B)

Model Number \_\_\_\_\_

Serial Number \_\_\_\_\_

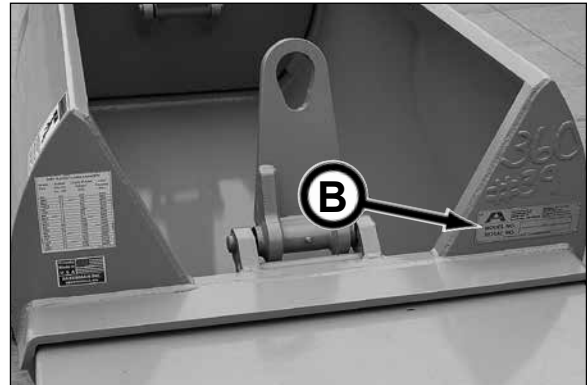

## ELECTRIC MOTOR (C)

Model Number \_\_\_\_\_

Serial Number \_\_\_\_\_

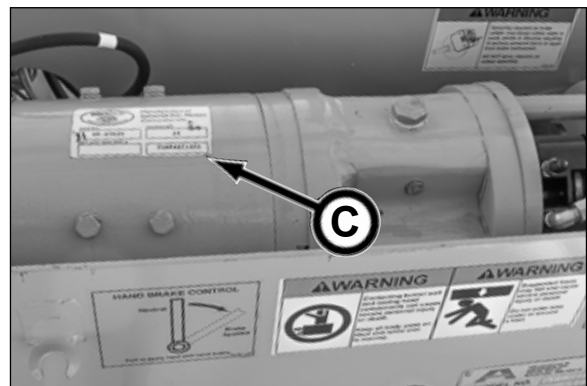

## **NOTES**

# Safety Data Sheets

The Federal Occupational, Safety, and Health Administration (OSHA) Standard 29 CFR 1910.1200, requires that specific safety data sheets (SDS) be available to employees before operating this equipment. This may include information on substances contained in this equipment such as antifreeze, brake fluid, battery acid, hydraulic fluid and gear lubricant.

Akkerman Inc. will provide, at no cost, SDS which apply to its product line. Simply contact your Akkerman Aftermarket Support representative for a copy.

To ensure a prompt response to your SDS request, include your return address (including zip or postal code) and the equipment's model numbers and serial numbers with your request.

## **NOTES**

# Warranty

Akkerman, Inc. warrants that all equipment manufactured by it be free from defects due to workmanship or material when normally used and serviced for a period of 90 days from the date of shipment by Akkerman, Inc. Normal wear and tear to the equipment, including, but not limited to brakes and wheels are not covered by this warranty. Akkerman, Inc. does not warrant that the equipment meets the requirements of any particular safety code or rule governing equipment classification. If the Customer has questions about local safety codes, rules or ordinances, authorities local to the project should be consulted.

In order to be considered as a potential warranty claim, the components in question must be returned to Akkerman, Inc. (freight prepaid) for factory inspection and analysis, and determination of warranty applicability. No warranty is provided for electronics or electrical components of any kind. The validity of all warranty claims are subject to the discretion and determination of the Akkerman Aftermarket Support Department. All such determinations are final.

*Warranty*

## **NOTES**

# Index

## A

Adapter, track ..... 6-3  
Adjust steering ..... 6-4  
Axle pivot pin, idler ..... 9-10

## B

Battery compartment cover ..... 9-6  
Battery maintenance ..... 9-17  
Battery pack ..... 6-10  
Battery, maintain safely ..... 1-2  
Bearings, idler wheel ..... 9-10  
Brake, hydraulic hand ..... 4-2, 6-7, 9-13  
Brushes, motor ..... 9-16  
Bucket, dirt hardware ..... 9-18  
Bucket, dirt lubrication ..... 9-12  
Bucket, using dirt ..... 6-8

## C

Cart, inspection ..... 6-9  
Charging battery ..... 6-10  
Charging plug, clean ..... 9-15  
Chart, torque ..... 12-2  
Charts, maintenance ..... 9-2  
Clean charging plug ..... 9-15  
Clean equipment ..... 1-3  
Clothing, protective ..... 1-1  
Contact with tunnel wall ..... 1-4  
Contactor shield, inspect ..... 9-6  
Contactors, clean ..... 9-6  
Contents ..... ii  
Controller function ..... 4-1  
Controller location ..... 4-1  
Controller, inspection ..... 9-7  
Controls & instruments ..... 4-1  
Conventional operation ..... 6-7  
Conveyor contact ..... 1-5

## D

Decals, safety ..... 2-1  
Dirt bucket hardware ..... 9-18  
Dirt bucket lubrication ..... 9-12  
Dirt bucket, inspect ..... 9-5  
Dirt bucket, using ..... 6-8

## E

Electrical schematic ..... 11-2  
Equipment, clean ..... 1-3  
Equipment, inspect ..... 1-3  
Exposure, laser light ..... 1-6

## F

Fire prevention ..... 1-2  
First aid kit ..... 1-1  
Frame rails ..... 9-11

## G

Gear box lubricant fluid level ..... 9-9  
Gear box lubricant ..... 8-1  
Gear reducer lubricant ..... 8-1  
Gear reducer mounting torque ..... 9-9  
Gear reducer pressure relief ..... 9-18  
Gear reducer seals ..... 9-9  
Gear reducer, drain & fill ..... 9-15  
Gear reducer, inspect ..... 9-5  
Grease ..... 8-1  
Guidelines, operation ..... 6-1  
Guidelines, transporting ..... 7-1

## H

Hand brake, hydraulic ..... 4-2, 6-5, 9-13  
Haul unit operation ..... 6-6  
Haul unit electrical schematic ..... 11-2  
Haul unit set up ..... 6-2  
Haul unit, inspect ..... 9-5  
Hydraulic hand brake ..... 4-2, 6-7, 9-13

## I

Identification numbers ..... 13-1  
Idler axle pivot pin ..... 9-10  
Idler wheel bearings ..... 9-10  
Inching ..... 6-7  
Information, safety ..... 1-1  
Inspect dirt bucket ..... 9-5  
Inspect equipment ..... 1-3  
Inspect gear reducer ..... 9-5  
Inspect haul unit ..... 9-5  
Inspect operator platform ..... 9-5  
Inspection cart, check ..... 9-18  
Inspection cart, using ..... 6-9  
Inspection, pre-start ..... 5-1  
Installing track ..... 6-3  
Instruments & controls ..... 4-1  
Introduction ..... i

## L

Laser light exposure ..... 1-6  
Lifting eye lubrication ..... 9-12  
Light, laser ..... 1-6  
Loads, suspended ..... 1-3  
Lockout tagout power ..... 1-5, 9-1  
Lubricant storage ..... 8-2  
Lubricant, gear box ..... 8-1  
Lubricant, gear reducer ..... 8-1  
Lubricants ..... 8-1

*(continued on next page)*

Index

<b>M</b>		<b>S</b>	
Maintenance charts .....	9-2	Safe maintenance .....	1-3
Daily or every 10 hours or shift change .....	9-2	Safety .....	1-1
Weekly or every 50 hours.....	9-3	Safety data sheets.....	14-1
Monthly or every 250 hours .....	9-4	Safety decals .....	2-1
Maintenance chart service detail		Safety information .....	1-1
Daily or every 10 hours or shift change .....	9-5	Schematic electrical.....	11-2
Weekly or every 50 hours.....	9-9	Seals, gear reducer .....	9-9
Monthly or every 250 hours .....	9-15	Serial numbers .....	13-1
Maintenance, battery .....	9-17	Setting up haul unit.....	6-2
Maintenance, periodic .....	9-1	Sliding track .....	6-3
Maintenance, practice safe .....	1-3	Smoking.....	1-5
Manual, read .....	1-1	Specifications .....	12-1
Material safety data sheets.....	14-1	Steering, adjust for steering.....	6-4
Motor brushes, clean.....	9-16	Steering haul unit.....	6-4
Motor hardware, check.....	9-16	Storage.....	10-1
		Storage, preparation.....	10-1
		Storage, removing .....	10-1
		Storing lubricants.....	8-2
		Suspended loads.....	1-3
<b>N</b>		<b>T</b>	
Nonconventional operation.....	6-7	Terminology .....	3-1
Numbers, identification .....	13-1	Torque chart.....	12-2
		Torque, gear reducer mounting .....	9-9
		Track adapter .....	6-3
		Track risers.....	6-3
		Track.....	6-3
		Track, inspect .....	9-7
		Transporting .....	7-1
		Troubleshooting.....	11-1
		Tunnel ventilation .....	1-4
		Tunnel wall contact.....	1-4
		Tunnel, smoking in .....	1-5
<b>O</b>		<b>U</b>	
One-call notification.....	5-1	Using dirt bucket.....	6-8
Operating haul unit .....	6-4		
Operation guidelines.....	6-1		
Operation.....	6-1		
Operation, conventional.....	6-7		
Operation, nonconventional.....	6-7		
Operator platform, inspect .....	9-5		
<b>P</b>		<b>V</b>	
Pack, battery.....	6-10	Ventilation test.....	1-4
Periodic maintenance .....	9-1		
Plug, clean charging.....	9-15		
Power lockout tagout.....	9-1		
Practice safe maintenance .....	1-3		
Preparing for storage.....	10-1		
Pressure relief, gear reducer.....	9-18		
Pre-start inspection.....	5-1		
Protective, clothing .....	1-1		
<b>R</b>		<b>W</b>	
Rails, frame .....	9-11	Wall contact.....	1-4
Read manual .....	1-1	Warranty .....	15-1
Recharging .....	6-10	Waste, recycle.....	1-6
Recharging, battery pack.....	6-10	Welding, unauthorized.....	1-6
Recycle waste .....	1-6		
Reducer lubricant .....	8-1		
Removing from storage .....	10-1		
Riders off haul unit.....	1-2		
Risers, track.....	6-3		