



OPERATOR'S MANUAL

Akkerman Bentonite Injection System (ABIS)

ABIS Control Station SN: FA15350F

Remote Station Control Box SN: FA15311F

Publication No. 050127A

Rev. No. 180212

© Akkerman Inc. 2018
All Rights Reserved

Akkerman Inc. 58256 266th Street Brownsdale, MN 55918
Phone: 507-567-2261 Fax: 507-567-2605 email: akk@akkerman.com

SERVICE • RELIABILITY • INNOVATION

Introduction

This operator's manual contains important safety, operation, and maintenance information for your Akkerman Bentonite Injection System. You must read and understand this manual and the any other tunneling equipment manuals before you operate and maintain the injection system and tunneling equipment. Keep this manual with your equipment at all times. Additional copies of this manual is available from the Akkerman Aftermarket Support Department.

The contractor is responsible for the overall safety program on the job site. Use this manual as a part of the safety program.

The use of second rate parts could affect the efficient performance of the ABIS system. ALWAYS use genuine Akkerman parts.

Understand safety signal words, DANGER, WARNING, CAUTION, SAFETY INSTRUCTIONS, and NOTICE. When you see these words in this manual or on safety decals mounted on your equipment, follow the safety message to avoid personal injury and/or property damage.

⚠ DANGER Indicates an extremely hazardous situation which, if not avoided, WILL result in death or serious injury.

⚠ WARNING Indicates a potentially hazardous situation which, if not avoided, COULD result in death or serious injury.

⚠ CAUTION Indicates a potentially hazardous situation, which, if not avoided, MAY result in minor or moderate injury. It may also be used to alert against unsafe practices.

SAFETY INSTRUCTIONS Usually consists of individual messages stating procedures or actions that must be followed for the safe operation of a product.

NOTICE Identifies potential property damage and important installation, operator, or maintenance information.



Akkerman Bentonite Injection System (with Simulated Tunnel Pipe)

The Akkerman Bentonite Injection System (ABIS) is a volume based, centrally controlled, automated bentonite injection system that will reduce jacking forces during pipe jacking and microtunneling operation. The system is controlled from a touch screen (resistive) monitor which regulates and displays the valve injection volume, valve flow volume, pressure and injection sequence, IJS extend and retract, and each remote station tunnel box tunnel lights.

Each remote station control box can control up to three automated injection ball valve assemblies for precise bentonite injection at the desired location. The control boxes also allow the control and monitoring of the intermediate jacking station functions and station box tunnel lights. This state-of-the-art bentonite injection system can be utilized as a standalone system for any tunneling, pipe jacking or microtunneling application, regardless of equipment manufacturer.

If you find any errors with this manual or know of ways to improve procedures, please let us know. Mail your suggestions to: Akkerman Inc, ATTN: Technical Publications, 58256 266th Street, Brownsdale, MN 55918.

Akkerman Inc. reserves the right to improve its product without notice or obligation.

NOTES

Contents

Safety	1	Transporting	7
Decals	2	Lubricants	8
Terminology	3	Periodic Maintenance	9
ABIS - Control Station	3-1	Maintenance Charts	9-2
Remote Station Control Box	3-2	Prior To Each Job Launch	9-2
Automated Bentonite Injection Valve.....	3-3	Daily Or Every 10 Hours Of Operation	9-3
Controls & Instruments	4	Completion Of Each Drive	9-4
ABIS Software	4-1	Annually	9-4
System Menu Screen	4-2	Maintenance Procedures	
Bentonite Control Screen (Main Screen)	4-3	Prior To Job Launch	9-5
Valve Sequence Screen	4-4	Daily Or Every 10 Hours Of Operation	9-10
Tunnel Light Control Screen	4-5	Completion Of Each Drive	9-12
IJS Control Screen	4-6	Annually	9-15
IJS Setup Screen	4-7	Storage	10
Pre-Start Inspection	5	Troubleshooting	11
Operation	6	ABIS System	11-1
Operating Guidelines	6-1	Automated Injection Valves	11-2
Overview	6-2	Intermediate Jacking Stations	11-2
Typical ABIS System Tunnel Layout With IJS ...	6-3	Electrical Schematics	
Typical ABIS System Tunnel Layout w/out IJS..	6-3	ABIS Monitor (SN FA15350F01)	11-4
Assembling The ABIS System	6-4	ABIS Monitor (SN FA15350F02 & After) ..	11-5
Monitor To Control Station	6-4	ABIS Station (Part 1 of 2)	
Monitor To Remote Station Box	6-5	(SN FA15350F-01).....	11-6
Remote Station Box to Automated Valve ...	6-6	ABIS Station (Part 2 of 2)	
Installing Additional Station Boxes	6-7	(SN FA15350F-01).....	11-7
Remote Station Control Box to IJS Station ..	6-8	ABIS Station (Part 1 of 2)	
Installing Bentonite Hoses	6-9	(SN FA15350F-02 & After).....	11-8
Setting Up The Valve Sequence	6-10	ABIS Station (Part 2 of 2)	
Valve Sequence Setup	6-10	(SN FA15350F-02 & After).....	11-9
Setting Up For Auto Operation	6-11	Specifications	12
Preparing The ABIS System for Operation...	6-12	ABIS System	12-1
Operating The ABIS System	6-14	Torque Chart	12-2
Operating The ABIS System in Manual Mode	6-15	Identification Numbers	13
Controlling The Tunnel Lights	6-16	Safety Data Sheets	14
Cold Weather Operation	6-17	Warranty	15
Adding New Pipe & Utilities	6-18	Index	16
Daily Shut Down	6-19		
Data Logging	6-20		
System Message Notifications	6-22		
Connecting ABIS System To Control Cont. ...	6-23		
Setting Up The IJS Stations	6-24		
Operating The IJS Stations With The ABIS..	6-25		

NOTES

Safety

BE ALERT FOR SAFETY INFORMATION

When you see this safety alert symbol on your equipment or in this manual, be alert to the possibility of personal injury or property damage.

Read all safety information.

Keep safety decals clean and in good condition. Replace missing or damaged safety decals.



**ATTENTION!
BECOME ALERT!
YOUR SAFETY IS INVOLVED!**

READ OPERATOR'S MANUAL

⚠ WARNING Unsafe operation or maintenance can cause severe injury or death.

Read and understand the Operator's Manual before operating or servicing this equipment.

Any unauthorized modifications will void the warranty.

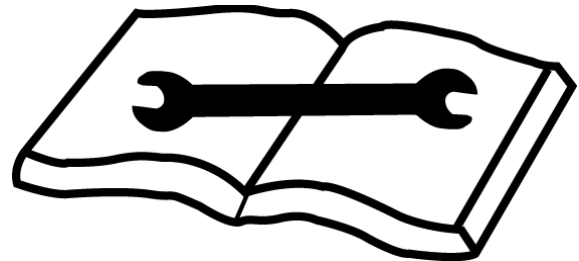

WEAR PROTECTIVE CLOTHING

Wear OSHA approved protective clothing, such as hard hat, gloves, safety goggles, earmuffs or ear plugs, face shield, and steel-toed boots, when operating and servicing this equipment.

Wear reasonably close fitting clothing and remove jewelry before working on or near this equipment. This will help prevent the danger of catching them in moving parts or controls.



AVOID LASER LIGHT EXPOSURE

⚠ DANGER Staring into laser light will cause severe injury.

Do not stare into laser guidance system light beam. Avoid direct eye exposure.

To avoid possible exposure to radiation in excess of acceptable emission limits, all repairs to laser must be performed by the original manufacturer or an authorized service technician.

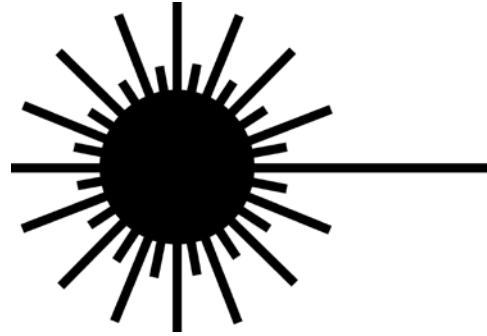

TEST SHAFT & TUNNEL VENTILATION

⚠ WARNING Keep shafts and tunnel well ventilated at all times.

Use an approved air analyzer to detect hazardous gases and oxygen content.

Before and during the shaft operation, test for combustible and toxic gases and oxygen deficiency.

If the levels exceed OSHA prescribed levels, leave tunnel and shaft immediately! Do not activate or deactivate any electrical or hydraulic devices, since any sparks could cause an explosion.

Once ALL personnel are out of tunnel/shaft, cut power from power source.

Gases must be removed before reentering tunnel/shaft.

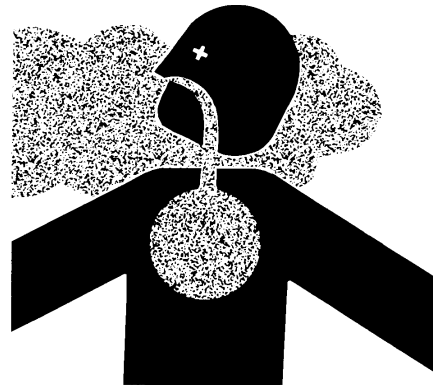

LOCKOUT POWER BEFORE SERVICING

⚠ DANGER Failure to lockout power before servicing will cause severe personal injury or death.

LOCKOUT main power supply before servicing. Electrical repairs must be performed only by a certified electrician.



PRACTICE SAFE MAINTENANCE

⚠ WARNING Unexpected equipment movement may cause serious personal injury.

LOCKOUT power before performing any maintenance.

Shut down equipment before making repairs, adjustments, or removing obstructions.

Only trained and qualified personnel should perform maintenance or repairs.

Keep the area around the equipment clean and dry when performing maintenance.

Do not service the machine while it is in motion.

Replace worn or damaged parts. Remove grease, oil, or debris buildup.



BEWARE OF SUSPENDED LOADS

⚠ WARNING Suspended loads may fall and cause severe personal injury or death.

If a hydraulic hose breaks from the boom of a crane/excavator, or the lifting support fails, the boom and/or load can fall instantly.

Do not enter area under or around a suspended load.



KEEP PERSONNEL AWAY FROM MOVING PARTS

⚠ WARNING Crushing hazard.

Keep personnel away from inside of jacking frame. Failure to do so could result in serious personal injury or death.

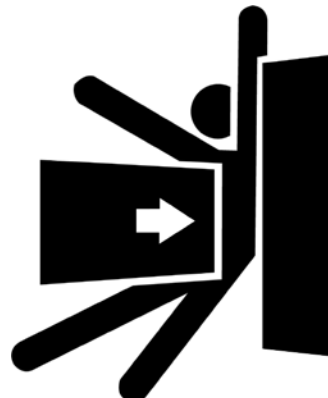

AVOID PINCH POINTS

⚠ WARNING Moving parts or the mishandling of parts can cause severe personal injury.

Keep hands away from moving parts.

Watch your fingers, hands, and legs while equipment is in operation.

Handle parts carefully to avoid crushing and pinch point hazards.

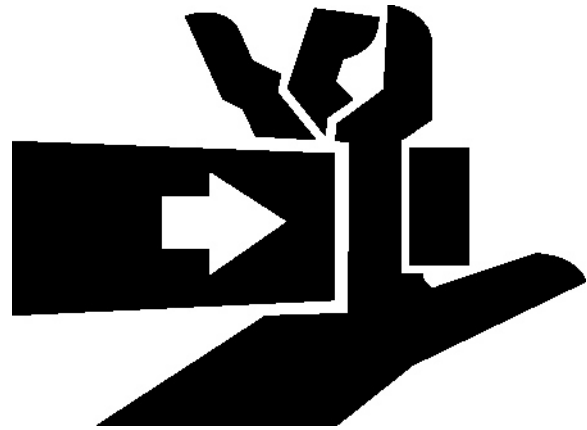

UNAUTHORIZED WELDING

⚠ WARNING Unauthorized welding can cause structural failure resulting in possible injury or death.

Do not weld on any structural member. Unauthorized welding or repair will void the warranty.

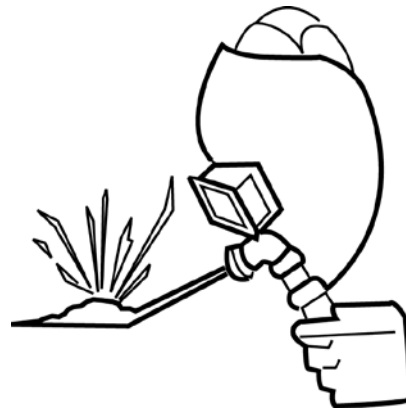

FIRE PREVENTION

⚠ CAUTION Fires can cause injury or property damage.

Keep equipment clean. Remove all debris from equipment.

Have a fire extinguisher available at all times. Keep the fire extinguisher fully charged.



SLIPPERY WHEN WET

⚠ WARNING Slips and falls can cause serious personal injury.

Ensure firm footing in wet or slippery conditions.

Replace skid-resistant material if it is damaged or missing to prevent slips and falls.

Remove any buildup of grease, oil, or debris.



KEEP JOB SITE CLEAN AND ORGANIZED

⚠ WARNING Tripping can cause serious personal injury.

Be sure to keep job site clean and organized.



NO SMOKING IN TUNNEL

⚠ WARNING Smoking in tunnel could cause an explosion if combustible gases are present.

Do not smoke in tunnel.



RECYCLE WASTE

Follow local, state, federal, and international regulations when recycling or disposing of waste. Waste includes fluids/oil, filters, coolant, and batteries.

Use leakproof containers when draining fluids/oil. Do not pour waste on the ground, down a drain, or into any water source.

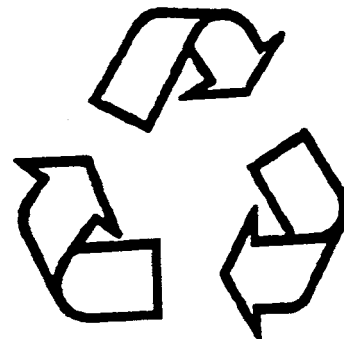

NOTES

Decals

Keep all operational and safety decals clean and readable. Use soft cloth, water, and a mild soap to clean the decals if they are too dirty to read. DO NOT clean decals with solvent. Solvent will damage the surface of the decal. Replace safety decals immediately if they are damaged, missing, or hard to read.

Serious injury or property damage can occur if operation and safety instructions are not followed. Contact your Akkerman Aftermarket Support representative for free replacement safety decals.

If a part is replaced that has a safety decal on it, apply a new safety decal to the replacement part. Before applying a new decal, be sure the surface is clean and dry.

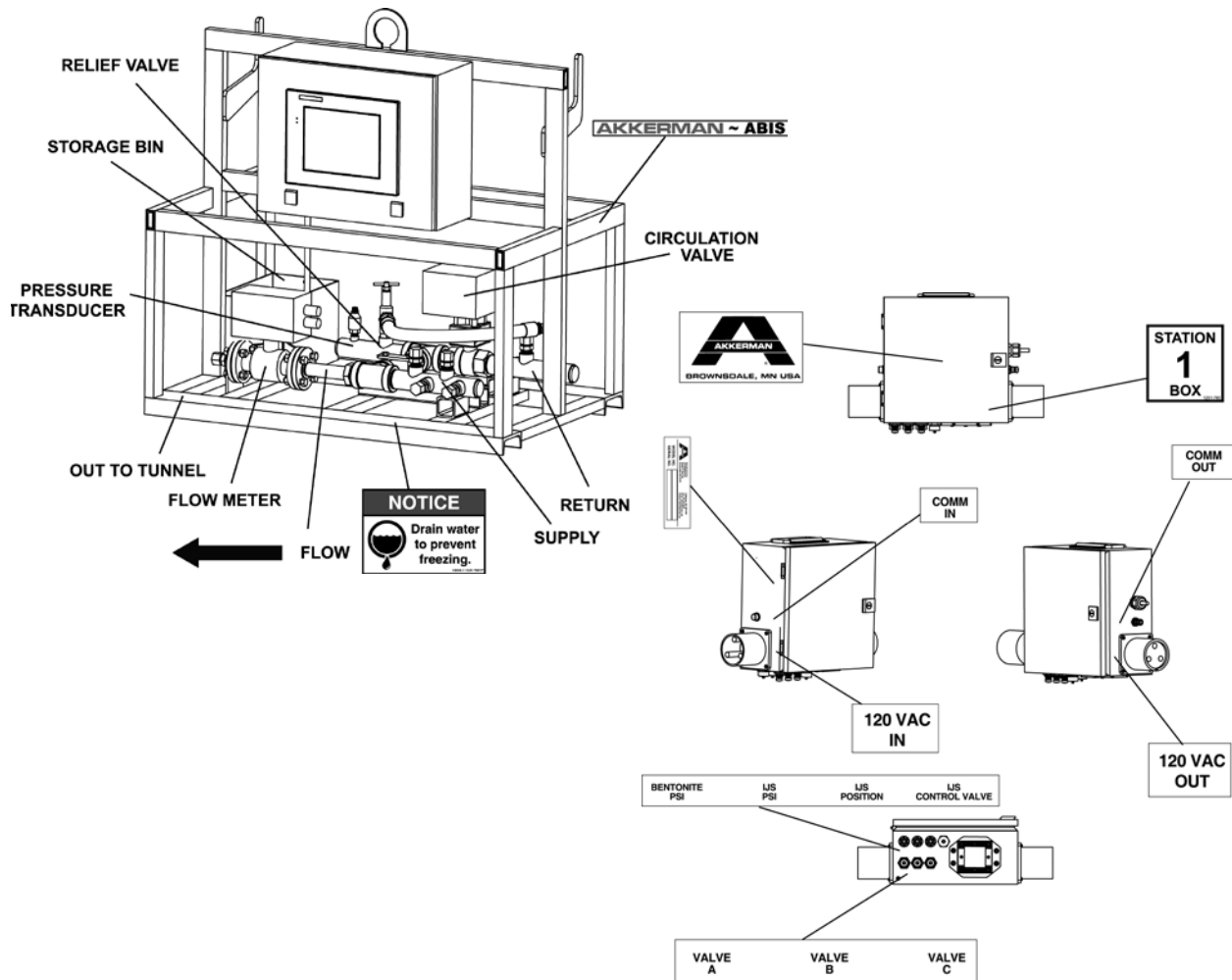

NOTES

Terminology

ABIS - CONTROL STATION

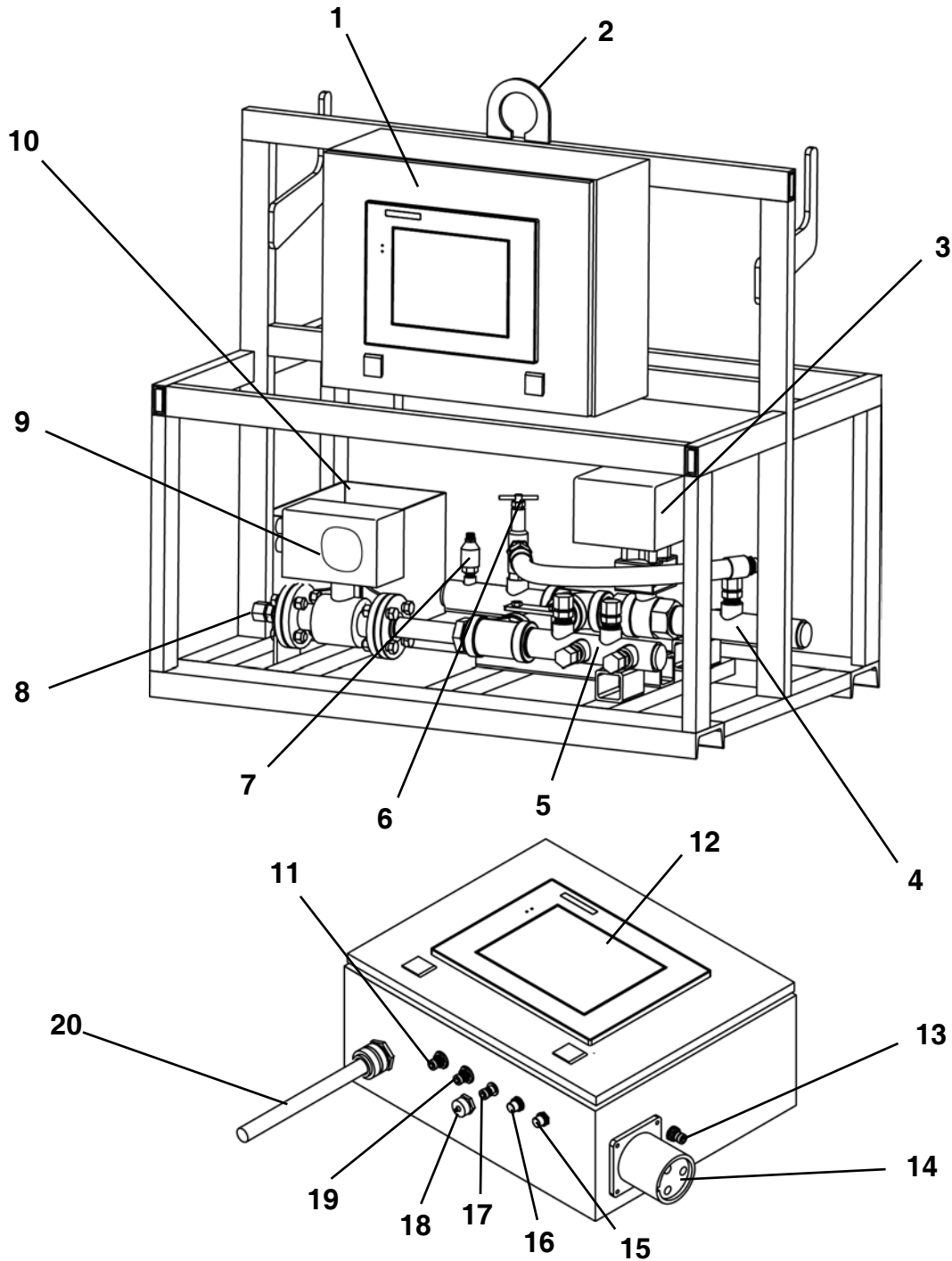

- | | |
|------------------------------------|--|
| 1. ABIS Electrical Control Box | 11. Bentonite Pressure Transducer Connection |
| 2. Lift Eye | 12. Monitor Touch Screen |
| 3. Circulation Valve | 13. Station Box Communication OUT Connection |
| 4. Return Manifold | 14. Station Box Power 120 VAC OUT Connection |
| 5. Supply Manifold | 15. HMI Ethernet Connection |
| 6. Relief Valve | 16. MTBM Ethernet IN Connection |
| 7. Pressure Transducer | 17. Bentonite Flow Meter Connection |
| 8. Supply - Out To Tunnel | 18. Bentonite Circulation Valve Connection |
| 9. Flow Meter With Digital Display | 19. IJS Pressure Transducer Connection |
| 10. Storage Bin | 20. 120 VAC IN - 100 ft. Cable |

REMOTE STATION CONTROL BOX

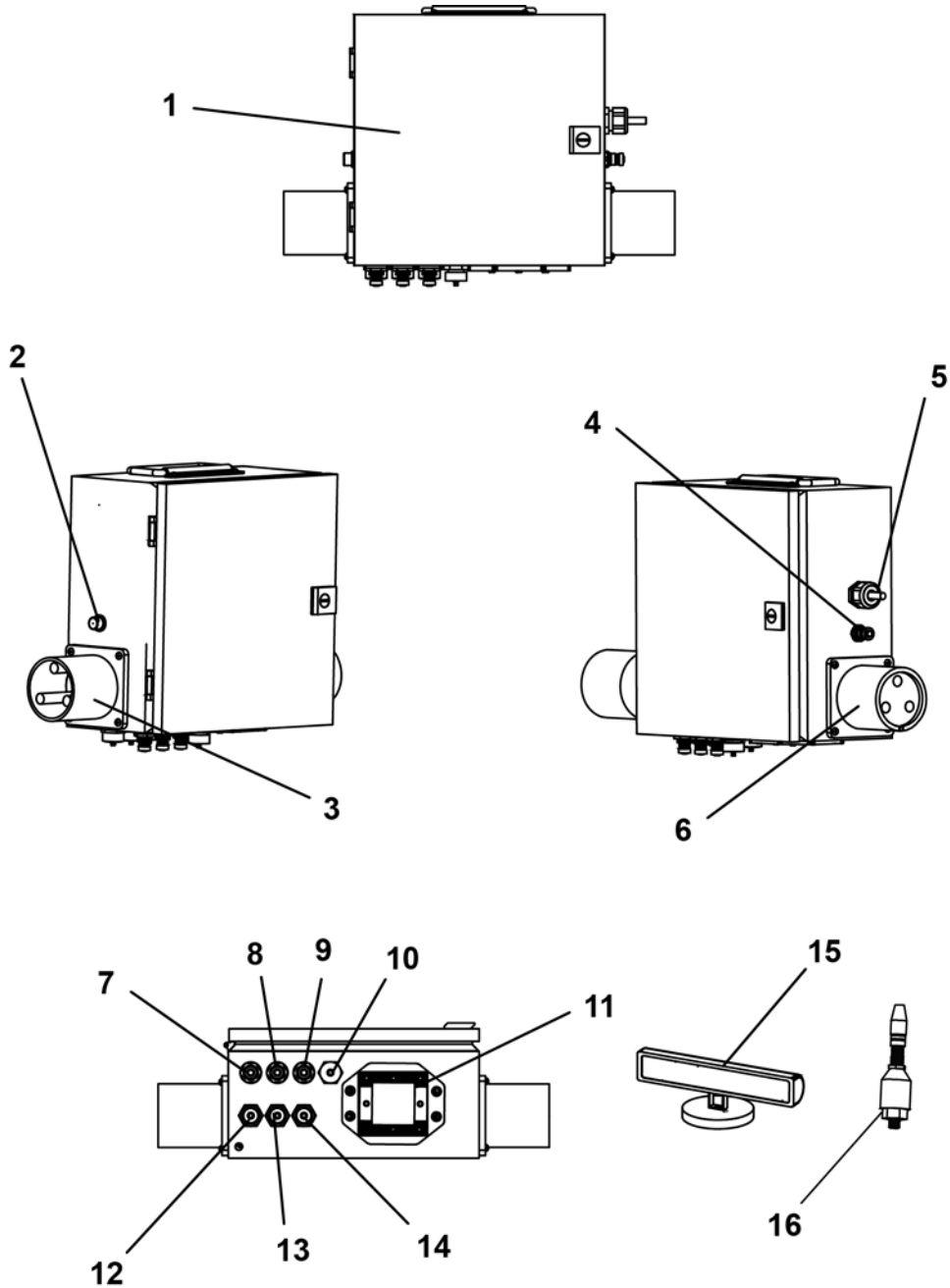

- | | |
|---|---|
| 1. Station Box | 9. IJS Position Connection |
| 2. Communication IN Cable Connection | 10. IJS Control Valve Connection |
| 3. 120 VAC IN Connection | 11. Tunnel Light |
| 4. Communication OUT Cable Connection | 12. Automated Injection Valve Pwr. Connection - A |
| 5. Remote Light Cable - 30 ft. | 13. Automated Injection Valve Pwr. Connection - B |
| 6. 120 VAC OUT Connection | 14. Automated Injection Valve Pwr. Connection - C |
| 7. Bentonite Pressure Transducer Connection | 15. LED Remote Magnetic Mount Work Light |
| 8. IJS Pressure Transducer Connection | 16. Bentonite Transducer |

AUTOMATED BENTONITE INJECTION VALVE

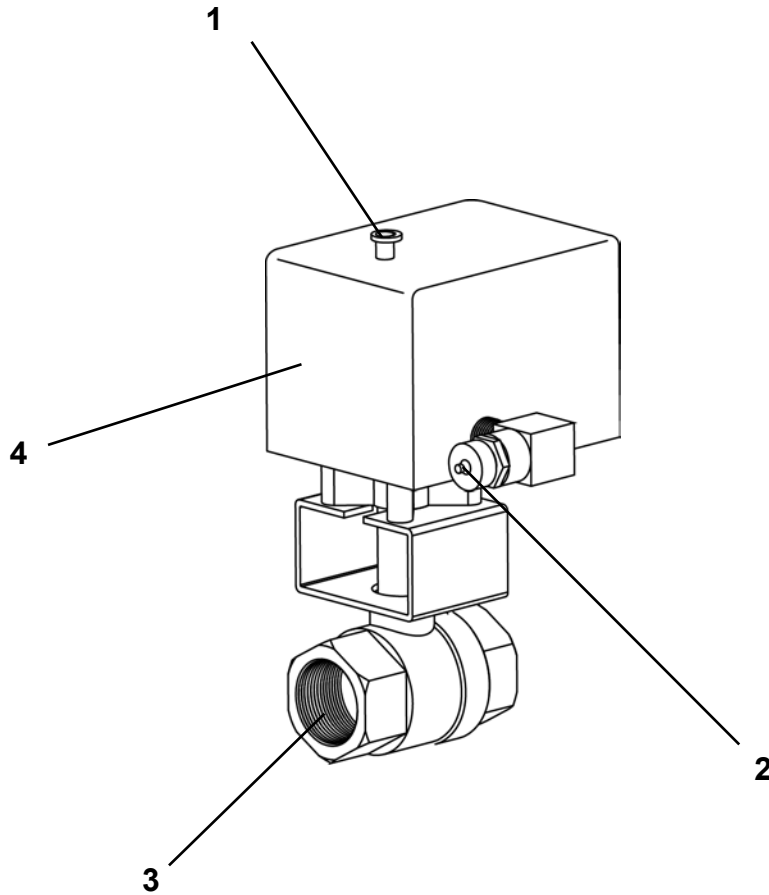

1. Position Indicator (Open or Closed)
2. Power Connection (from Station Box)
3. Bentonite Supply
4. Electric Actuator

NOTES

Controls & Instruments

ABIS SOFTWARE

The ABIS system user friendly software is controlled from a touch screen (resistive) monitor which regulates and displays the valve injection volume, valve flow volume, pressure and injection sequence, IJS extend and retract, and each remote station tunnel box tunnel lights.

This system can be used for in tunneling, pipe jacking and microtunneling applications regardless of equipment manufacturer.

System Menu Screen

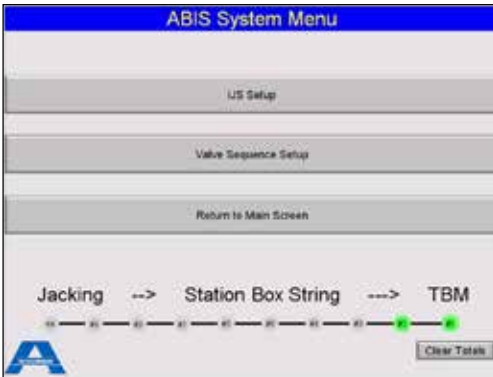

Bentonite Valve Sequence Screen



Bentonite Control Screen (Main Screen)



Tunnel Light Control Screen

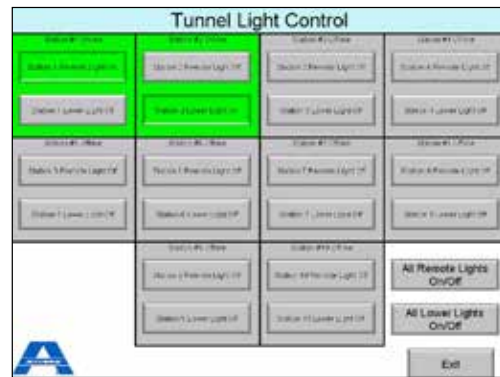

IJS Setup Screen



IJS Control Screen

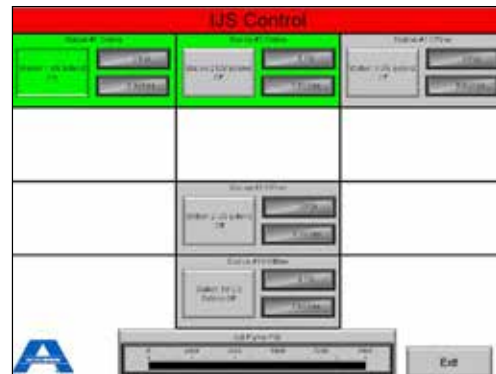

Clear Total Confirmation Screen

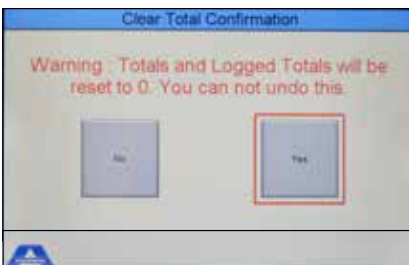

SYSTEM MENU SCREEN

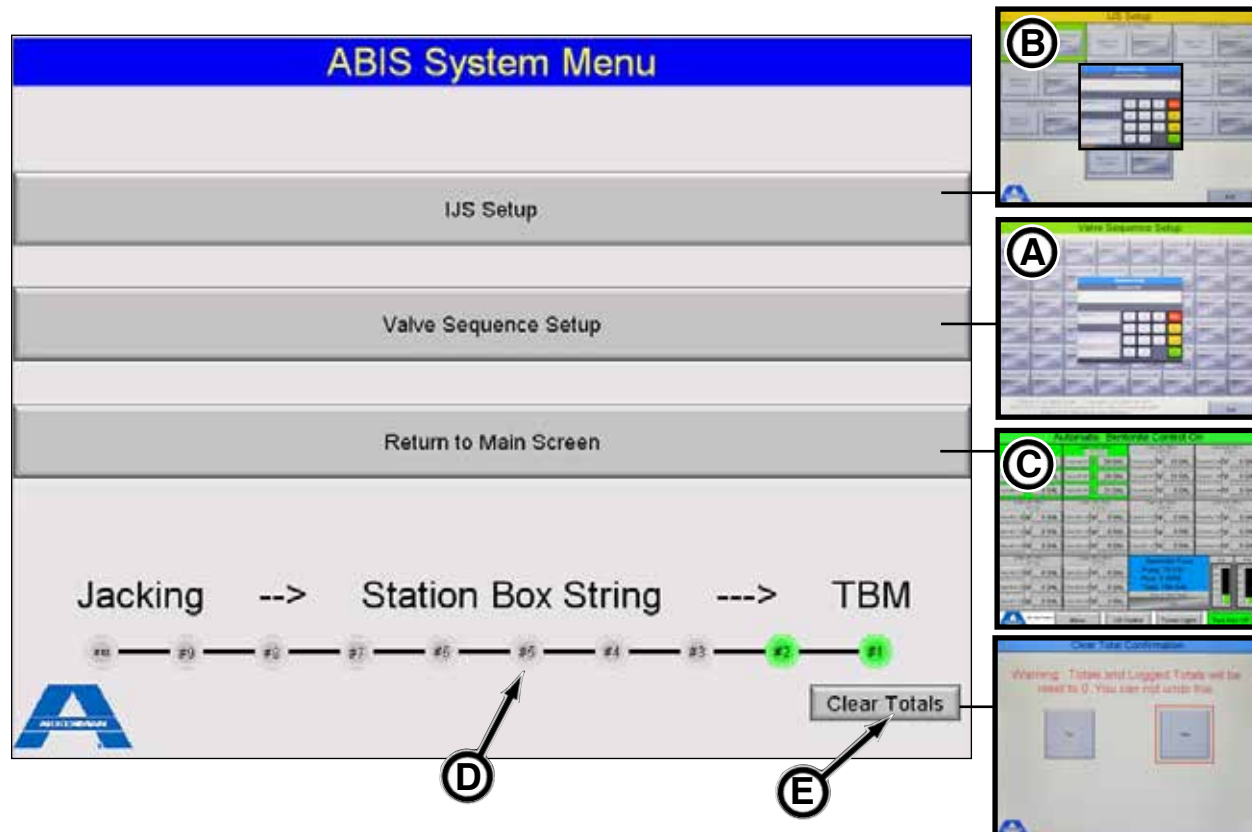

The ABIS system menu screen provides navigation to the Valve Sequence Setup screen (A), the IJS Setup screen (B) and the Return to Main Screen (C) (Bentonite Control screen).

This screen also displays a graphical representation of the station boxes (D) in the tunnel that are currently online (green) and offline (gray).

The Clear Totals button (E) provides a means to reset the data logging totals to zero. Therefore the next data logged will start at zero and previous data totals are retained. The totals are typically cleared prior to a new drive launch. Refer to Data Logging in section 6, Operation for more information.

NOTICE On all ABIS software screens, if a device is green, this indicates that the device has been properly hooked up and is online, ready to be used. If the device is gray, the device is offline, unavailable for use until it is properly hooked up.

BENTONITE CONTROL SCREEN (MAIN SCREEN)

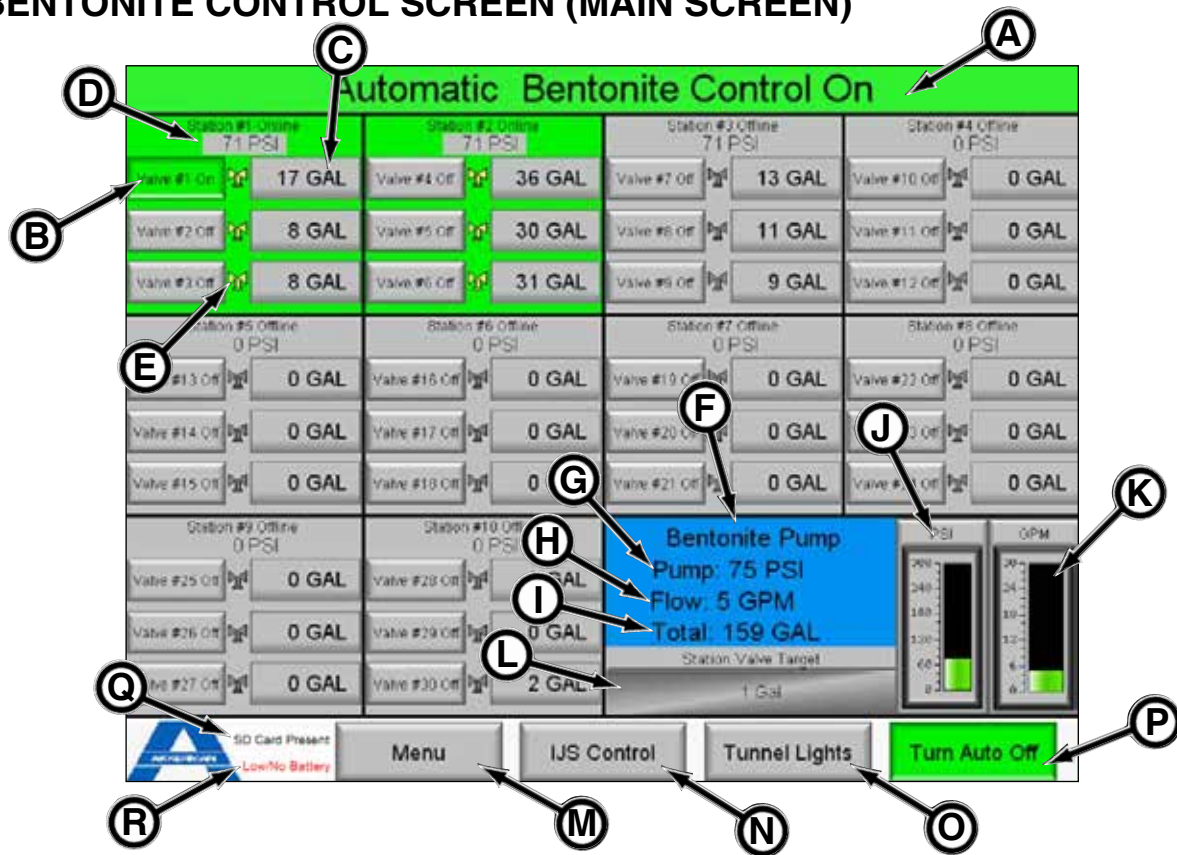

The Bentonite Control screen displays:

- Automatic bentonite control (A) is On (green) or Off (red).
- Status of each remote station box; Valve button On/Off (B), the volume dispensed (C) at each valve, the bentonite pressure (D) at each station box and a valve icon (E) indicating if the valve is operating. Valve icon indicators: Solid green - valve open, solid gray - valve closed, flashing - valve is traveling between open and closed position.
- Status of the bentonite pump output (F); pump bentonite pressure (G) at the pressure transducer on the control station, the flow (H) at the flow meter on the control station, and the total accumulated gallons (I) of bentonite pumped to all valves on the station boxes.
- Graphical display of the bentonite pump pressure (J) and the bentonite pump flow (K). This is redundant information from the status of the bentonite pump output, providing a quick visual display of the bentonite pump pressure and flow.
- Station valve target (L) amount in gallons; the amount of bentonite pumped to each sequenced valve when the automatic bentonite control is on. The target amount can be changed by simply pressing the Gal button and updating the gallon amount on the numeric entry window.
- Menu button (M) - this button navigates to the ABIS System Menu screen.
- IJS Control button (N) - this button navigates to the IJS Control Menu screen.
- Tunnel Lights button (O) - this button navigates to the Tunnel Lights Menu screen.
- Turn Auto ON/OFF button (P) - this button controls the automation of the bentonite to the station boxes/valves.

When selecting the Turn Auto Off button, if the station box is online, an individual valve button can be pressed to pump bentonite to that specific valve. This is a manual mode, therefore bentonite will continue to pump to the valve until the valve is pressed again to the off position.

- SD Card Present/No SD Card (Q) - this message appears when the SD card is/is not installed.
- Low/No Battery (R) - this message appears if the backup battery power is low or battery is not installed.

NOTICE

On all ABIS software screens, if a device is green, this indicates that the device has been properly hooked up and is online, ready to be used. If the device is gray, the device is offline, unavailable for use until it is properly hooked up.

VALVE SEQUENCE SETUP SCREEN

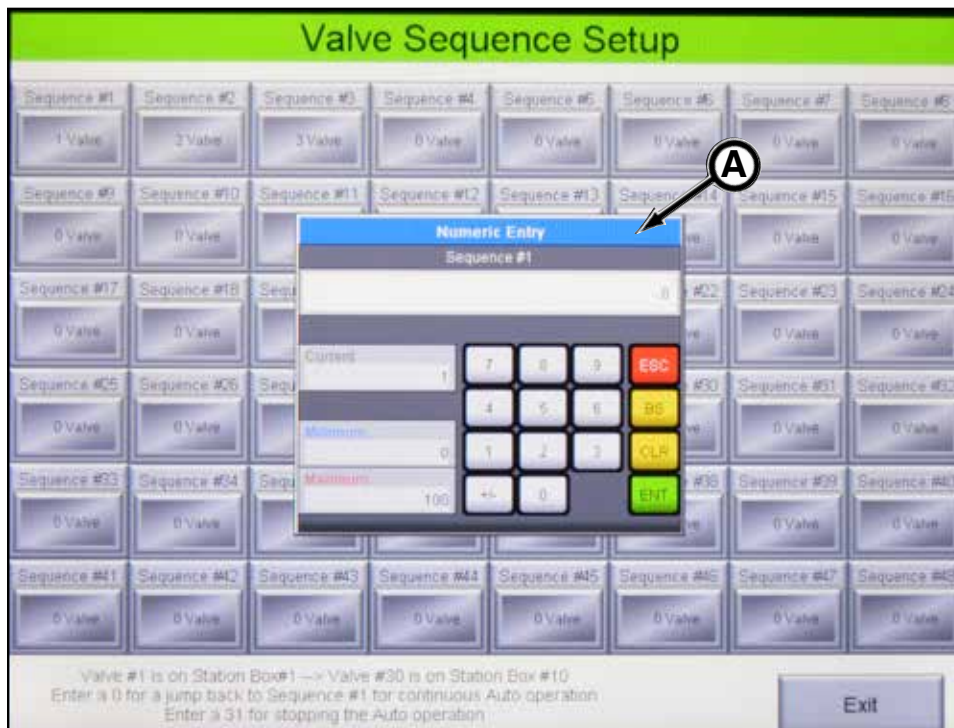

The sequence operation of the automated bentonite valves is arranged on the Valve Sequence Setup screen.

When setting up the sequence, keep in mind, there are 3 valves per station box. Therefore when setting up the valve sequence:

- Valves 1, 2 and 3 are with Station Box #1
- Valves 7, 8 and 9 are with Station Box #3
- Valves 13, 14 and 15 are with Station Box #5
- Valves 19, 20 and 21 are with Station Box #7
- Valves 25, 26 and 27 are with Station Box #9
- Valves 4, 5 and 6 are with Station Box #2
- Valves 10, 11 and 12 are with Station Box #4
- Valves 16, 17 and 18 are with Station Box #6
- Valves 22, 23 and 24 are with Station Box #8
- Valves 28, 29 and 30 are with Station Box #10

Sequence Setup:

1. Press the desired Sequence # box to display the numeric entry window.
2. Type the valve number per sequence in the Sequence #1, #2, #3, etc., press ENT to enter number.
3. Type a 0 to jump back to Sequence #1 for continuous auto operation.
4. Type a 31 into the desired sequence box to stop the auto operation.

For example in the graphic above, the automated operation will start at sequence #1- Valve 1, proceed to Sequence #2 - Valve 2, continue to Sequence #3 - Valve 3, Sequence #4 - Valve 1 repeating the sequence auto operation. If a 31 is typed into the Sequence #4 box, the auto operation will stop after the bentonite volume is pumped into Valve 1, Valve 2 and Valve 3.

NOTICE

On all ABIS software screens, if a device is green, this indicates that the device has been properly hooked up and is online, ready to be used. If the device is gray, the device is offline, unavailable for use until it is properly hooked up.

TUNNEL LIGHT CONTROL SCREEN

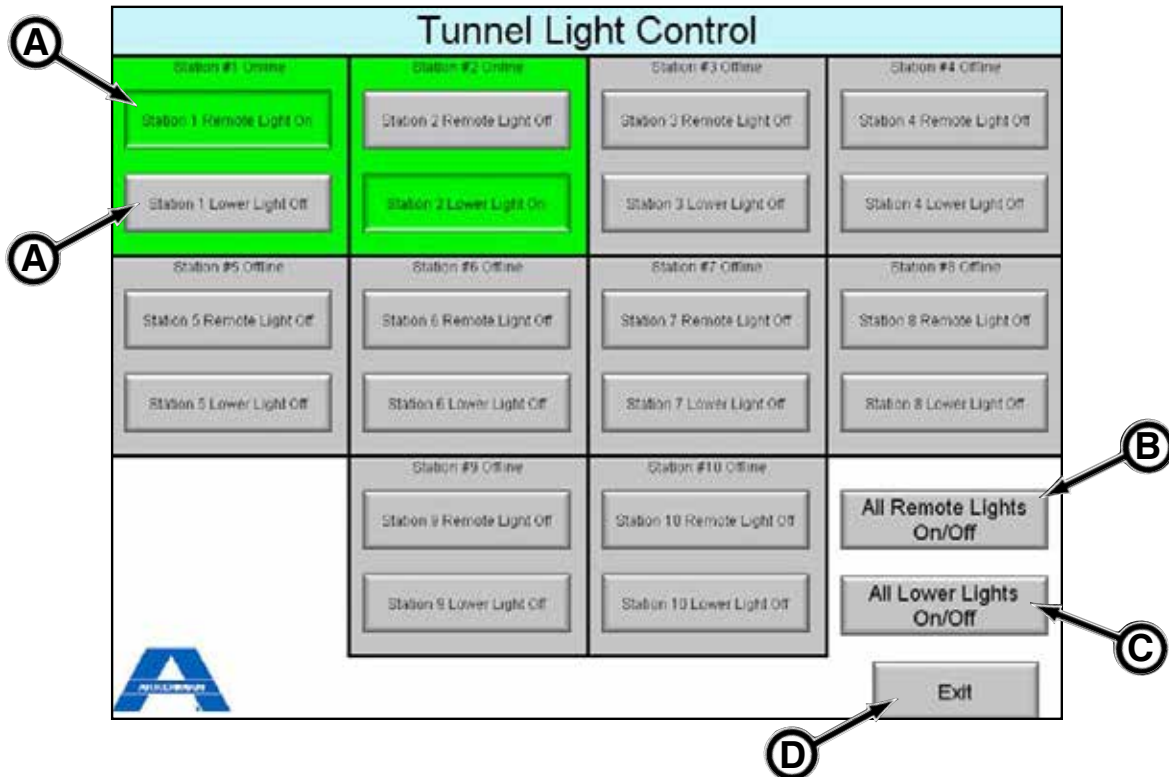

The Tunnel Light Control screen controls the operation of the remote work lights and the station box tunnel lights (lower lights).

The lights can be controlled individually at each online station box light button (A) or all lights can be controlled with the All Remote Lights On/Off button (B) and the All Lower Lights On/Off button (C).

Press Exit (D) to return to the Bentonite Control screen.

NOTICE On all ABIS software screens, if a device is green, this indicates that the device has been properly hooked up and is online, ready to be used. If the device is gray, the device is offline, unavailable for use until it is properly hooked up.

IJS CONTROL SCREEN (OPTIONAL)

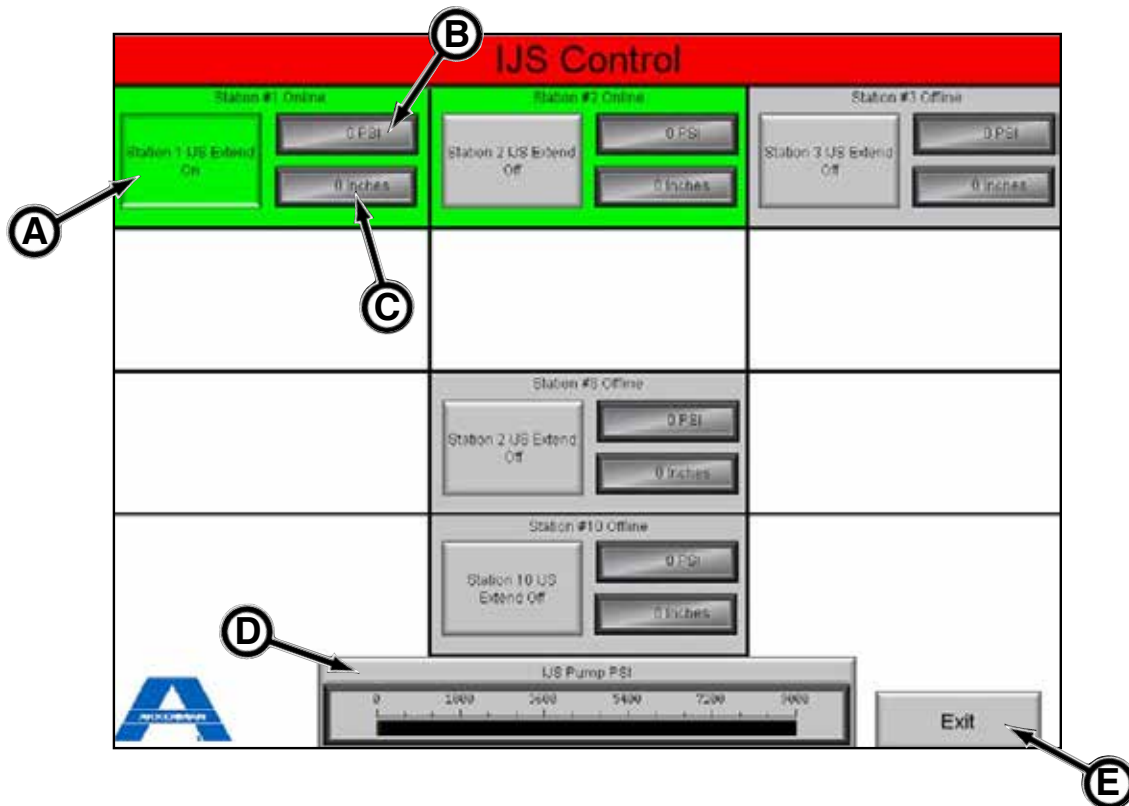

The IJS Control screen controls the operation of the IJS stations. Each station with an IJS station can be equipped with a pressure transducer and a linear transducer.

Press the Station IJS button (A) to activate the IJS station. The station pressure and cylinder extension will be visible on the pressure meter (B) and the linear meter (C). Once the IJS is fully extended, press the Station IJS button to deactivate the IJS.

An IJS Pump PSI gauge (D) will display the IJS pump hydraulic pressure.

Press Exit (E) to return to the Bentonite Control screen.

NOTICE On all ABIS software screens, if a device is green, this indicates that the device has been properly hooked up and is online, ready to be used. If the device is gray, the device is offline, unavailable for use until it is properly hooked up.

IJS SETUP SCREEN (OPTIONAL)

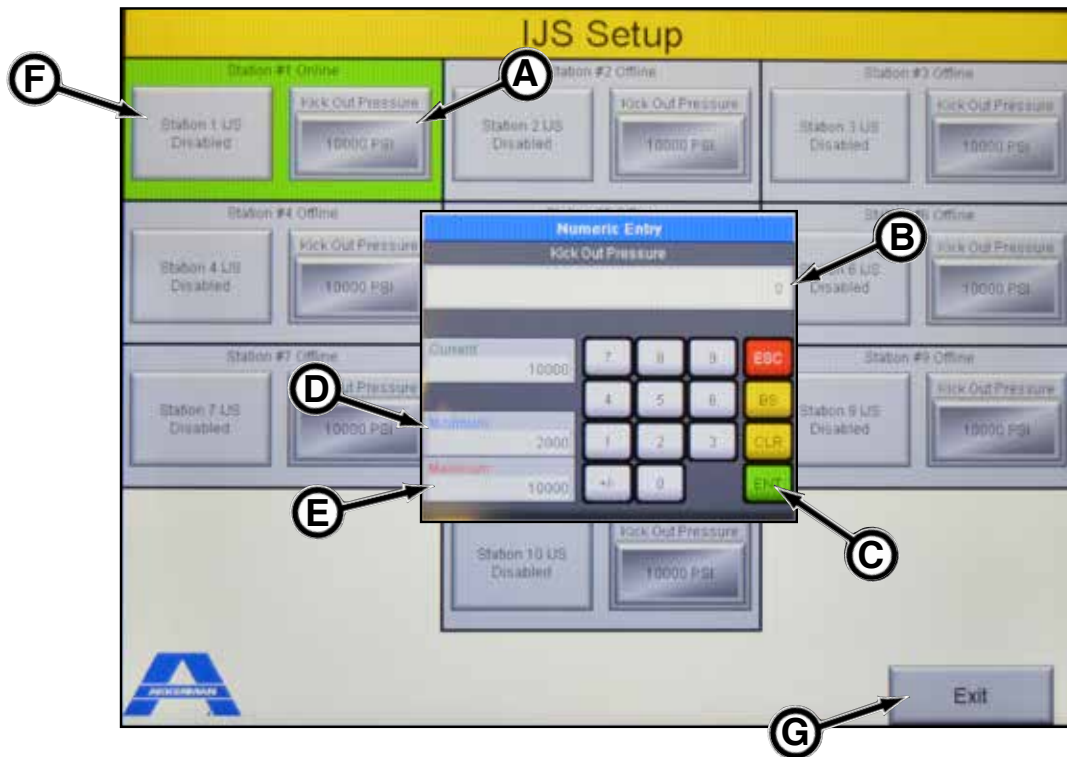

The IJS Setup screen enables/disables the IJS controls for each station and sets the hydraulic kick out pressure at each online IJS station.

To adjust the IJS hydraulic pressure at which the output will turn off, simply press the Kick Out Pressure button (A). A numeric entry window will appear. Type in the desired hydraulic pressure (B), then press ENT (C) (enter).

To enable/disable the IJS station, press the Station # box (F).

Press Exit button (G) to return to the Bentonite Control screen.

NOTICE On all ABIS software screens, if a device is green, this indicates that the device has been properly hooked up and is online, ready to be used. If the device is gray, the device is offline, unavailable for use until it is properly hooked up.

NOTES

Pre-Start Inspection

⚠ WARNING

Do not operate this equipment until you read, study, and understand this manual and any other equipment manuals that may be used. A daily inspection of the equipment must be performed to prevent severe personal injury or death and equipment damage.

The contractor is fully responsible for the safety of all personnel on the job site. Check with the contractor that all site preparation requirements are in place. Be sure to comply with all MSHA and OSHA regulations, such as: an active safety program is in practice, a confined space permit (if needed) is issued, personal protective equipment is being worn; flammable, combustible, and hazardous materials are properly stored; and a lockout/tagout procedure is in place.

Use the following checklist ✓ as a guide for your daily pre-start inspection.

	1. Follow the MSHA (Mining Safety & Health Administration) and OSHA (Occupational Safety & Health Administration) regulations.
	2. Contractor is responsible for all personnel to wear proper protective equipment on the job site. Replace equipment if defective.
	3. Combustible, toxic and oxygen deficiency detectors MUST be in place, tested, and in proper working condition.
	4. Inspect equipment for damage. Repair or replace as needed.
	5. Thoroughly clean equipment of mud and dirt.
	6. Install the bentonite pump hoses to the ABIS system and automated injection valves.
	7. Attach all communication and power cables from ABIS control station to station boxes and automated injection valves.
	8. Set up the valve sequence for the automated bentonite injection.
	9. Check tunnel lights for proper operation.
	10. Check ABIS system operation. Repair or replace as needed.
	11. Check for loose or missing hardware. Replace damaged or missing hardware.
	12. Check for worn, loose, or damaged cable connections. Repair or replace as needed.
	13. If operating in freezing weather, be sure to constantly circulate water/solution to prevent freezing.

NOTES

Operation

OPERATING GUIDELINES

⚠ WARNING

Do not operate this equipment until you read, study, and understand this manual and your tunneling equipment instruction manuals before you operate and maintain this equipment. Failure to do so, could result in severe personal injury or death.

1. Before operating, read and understand the Safety and Operation sections.
2. Do not operate this equipment while under the influence of alcohol, drugs, or medication.
3. Follow all Federal, State, and Local safety regulations and procedures.
4. Be sure OSHA prescribed safety personal protective equipment is being worn by all personnel.
5. Be sure the area is safe for operation. Keep work site clean and organized.
6. NEVER operate equipment if it has been engulfed with water. Contact your Akkerman Aftermarket Support representative for proper procedures on how to restore equipment for operation.
7. Have a fully charged fire extinguisher on the job site at all times.
8. Before operating, repair all equipment problems.
9. Be sure the excavated launch and reception pits or shafts are properly shored or braced to prevent slides or cave-ins.
10. Test air monitoring and ventilation detectors for proper operation. Never enter a tunnel without gas detectors.
11. A fully trained and qualified signal person must direct the excavator or crane operator when lifting and lowering equipment into the launch or reception pits.
12. Never walk or work under any part of the excavator or crane and suspended loads.
13. Lock out power at the source (generator) before servicing components.
14. In cold weather, constantly circulate solution systems to prevent freezing (refer to Cold Weather Operation in this section).
15. Test the operation of the bentonite pump. Connect supply and return hoses to ABIS system.
16. Properly setup the ABIS system prior to operation.
17. Be sure the ABIS system is installed with the SD card and a backup battery.
18. Setup bentonite injection valve sequence prior to operation. Test the operation of each injection valve.
19. Test all controls and lights to be sure they operate properly.
20. If using the IJS controls, be sure the IJS system is properly connected to the ABIS system.
21. If this manual is lost, contact your Akkerman Aftermarket Support representative for a new manual or download this manual from the Akkerman web site at www.akkerman.com.
22. Do not make any modifications to any Akkerman products. Doing so could cause structural failure and will void the warranty.

OVERVIEW

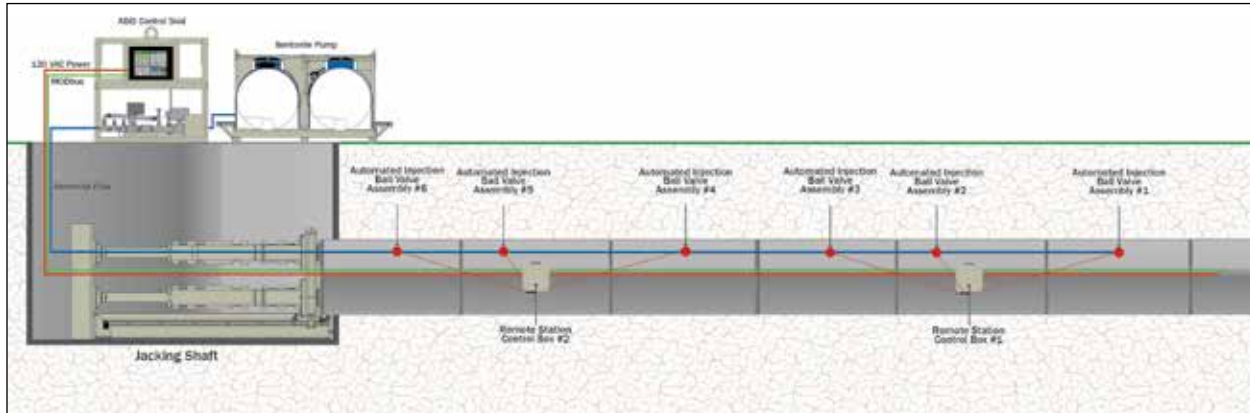

The Akkerman Bentonite Injection System (ABIS) is a volume based, centrally controlled, automated bentonite injection system that will reduce jacking forces during pipe jacking and microtunneling operation.

The ABIS system delivers total flow control at each automated bentonite valve location using a touch screen (resistive) monitor. This monitor regulates and displays the valve injection volume, valve flow volume, pressure and injection sequence, IJS extend, and each remote station box tunnel lights and work lights.

This ABIS system is comprised of a Control Station housing the flow meter and Monitor Touch Screen. It connects up to 10 Remote Station Control Boxes, each links up to three automated injection ball valve assemblies for precise bentonite injection at the valve location into the pipe annulus. The remote station control boxes also allows the control and monitoring of the intermediate jacking station functions and station box tunnel lights.



*Akkerman Bentonite Injection System
(with Simulated Tunnel Pipe)*

Specifically, the system is a distributed control system with control stations located along the length of the pipe. Each control station has electrical controls for bentonite injection valves that are ported through the wall of the pipe and are placed along that area of the pipe. As the pipe length in the ground is increased, new stations are added to the system to control the valves as additional pipe sections are added. The system operator station has the ability to control the bentonite injection valves manually or automatically based on how the operator wishes to operate the system. A specific volume of bentonite is dispensed to each valve before advancing on to the next valve in automatic mode. Pressures and injection volumes are data logged for future review.

The ABIS system is capable of being setup with an **advancement alarm system** to the MTBM control container. The pipe automatic Bentonite injection lubrication system will send a signal to the MTBM indicating advancement can continue. The system will supply the signal "on" to the MTBM when the automatic valve sequence is enabled or when a valve is being manual controlled via the system interface. If this signal from the system goes "off", first the operator will be given an alarm notification. This alarm will notify the operator that the pipe automatic Bentonite injection lubrication system is not actively supplying lubrication to the pipe. Once the signal goes "off" it will also start a timer in the MTBM control system, after 15 minutes the MTBM operator will be reminded with another alarm and the event will be entered into the log file. This periodic alarm is necessary for the period of time when the machine is boring in before the system is installed into the pipe.

The standard ABIS configuration provides microtunneling and pipe jacking contractors with components for a 2,000-linear foot tunnel, and the flexibility to suit a variety of project conditions.

This state-of-the-art bentonite injection system can be utilized as a standalone system for any tunneling, pipe jacking or microtunneling application, and bentonite lubrication pumps regardless of equipment manufacturer.

TYPICAL ABIS SYSTEM TUNNEL LAYOUT WITH IJS

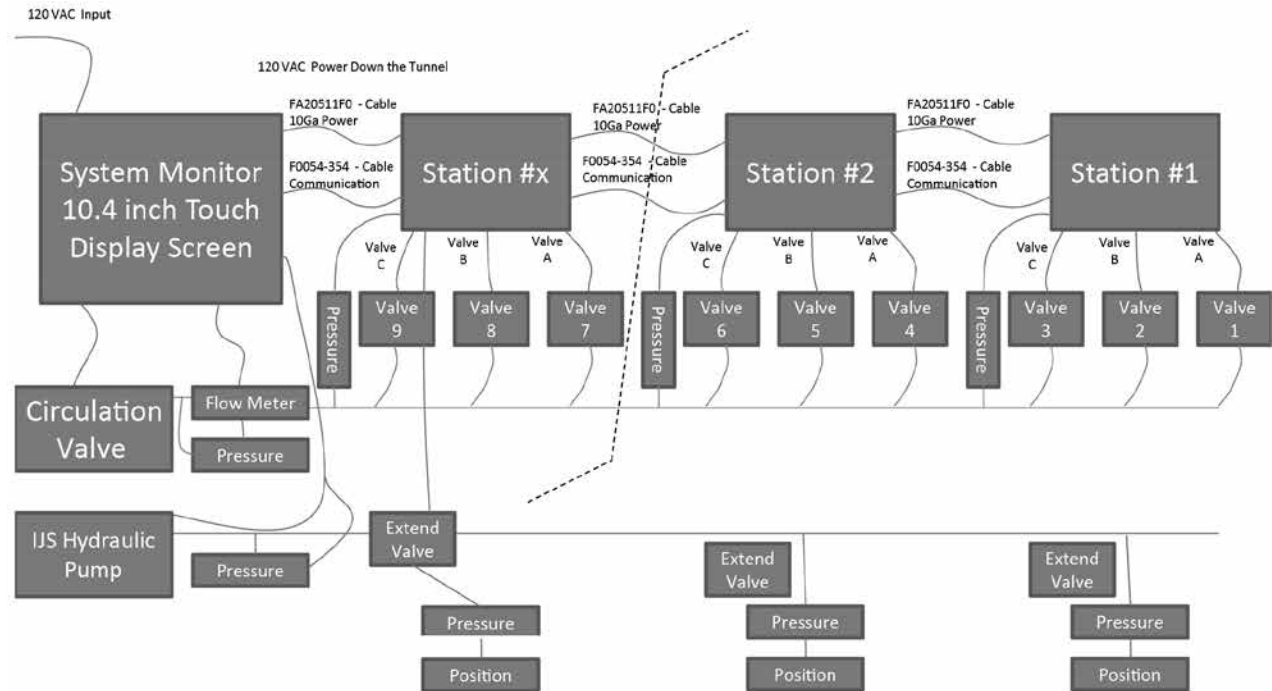

TYPICAL ABIS SYSTEM TUNNEL LAYOUT WITHOUT IJS

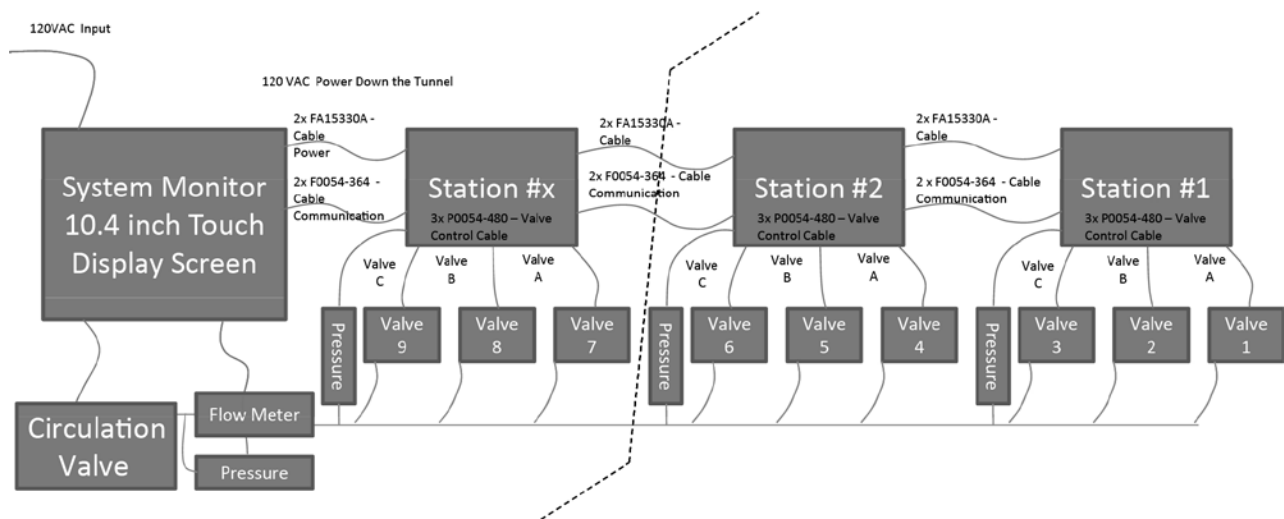

ASSEMBLING THE ABIS SYSTEM

MONITOR TO CONTROL STATION

1. Secure the monitor (A) to the control station (B) or in the microtunneling container.

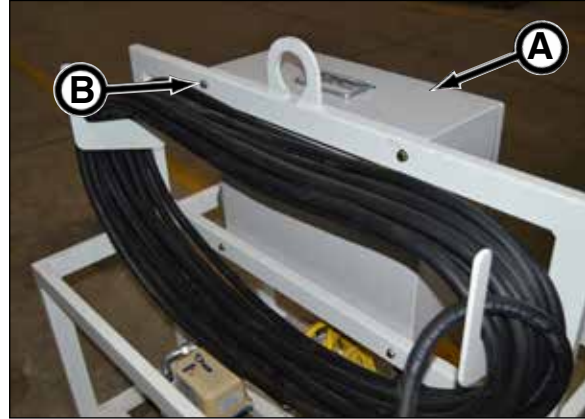

2. Connect cable (C) from flow meter to BENTONITE FLOW METER cable connection (D) on monitor.

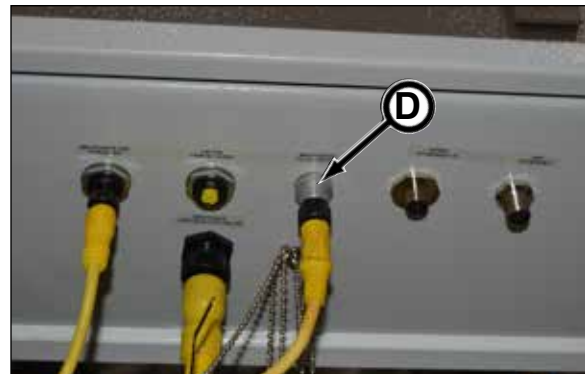
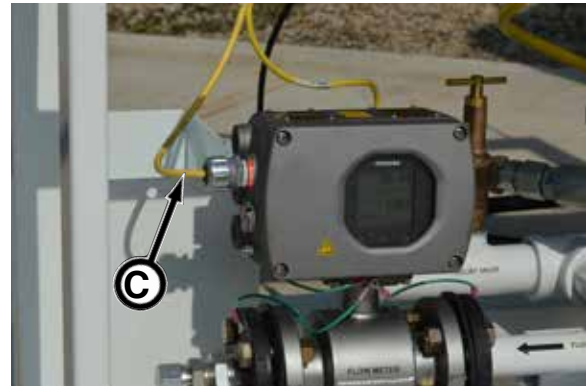

3. Connect cable from circulation valve connection (E) to BENTONITE CIRCULATION VALVE cable connection (F) on monitor.

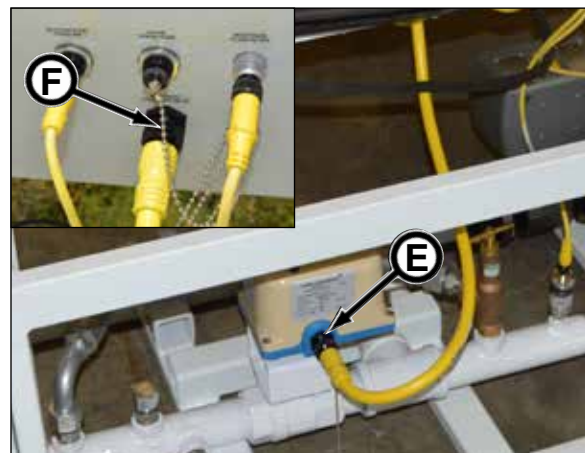

(Continued on next page)

4. Connect cable from bentonite pressure transducer connection (A) to BENTONITE PSI TRANS 300 connection (B) on monitor.

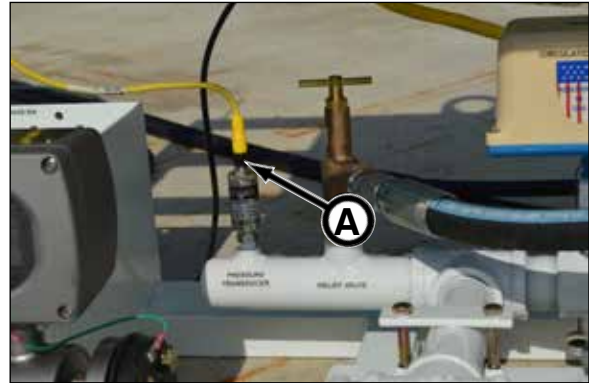

5. If an IJS station is used, the IJS PSI TRANS 10,000 cable connection (C) will be connected to the IJS pressure transducer cable connection at the IJS pump.

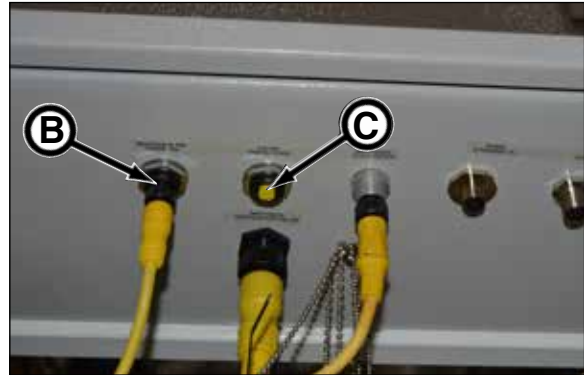

MONITOR TO REMOTE STATION CONTROL BOX 1

NOTICE When installing remote station control boxes in the pipeline, station box 1 **MUST** be located closest to the TBM/MTBM. As new pipe is set, install additional boxes in numerical sequence for ease of setting up valve sequence.

6. With the remote station control box mounted in the pipeline, connect communication cable from the STATION BOX COMM connection (D) on the monitor to the COMM IN connection (E) on the remote station control box.

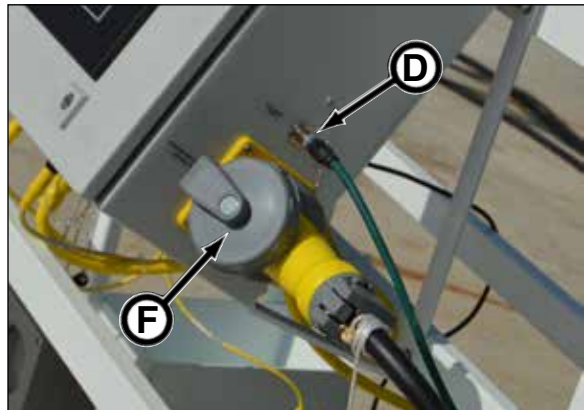

7. Connect power cable from the STATION BOX 120 VAC OUT connection (F) on the monitor to the 120 VAC IN connection (G) on the remote station control box.

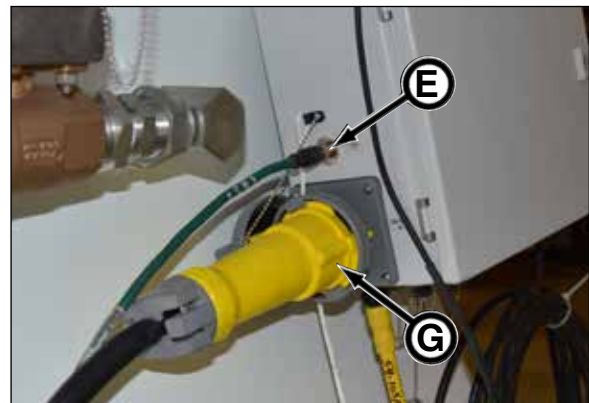
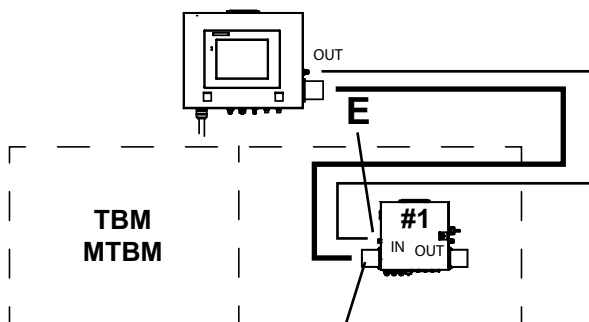

(Continued on next page)

REMOTE STATION CONTROL BOX TO AUTOMATED BENTONITE INJECTION VALVES

8. Connect cable from Valve A connection (A) on the remote station control box to the automated bentonite injection valve cable connection (B).
9. Connect cable from Bentonite PSI connection (C) to bentonite pressure transducer connection on the bentonite supply hose.
10. As additional pipe are added to the pipeline and more automated bentonite injection valves are installed, connect cable(s) to Valve B (D) and Valve C (E) and the other end of the cable(s) to the appropriate automated valve cable connection(s).

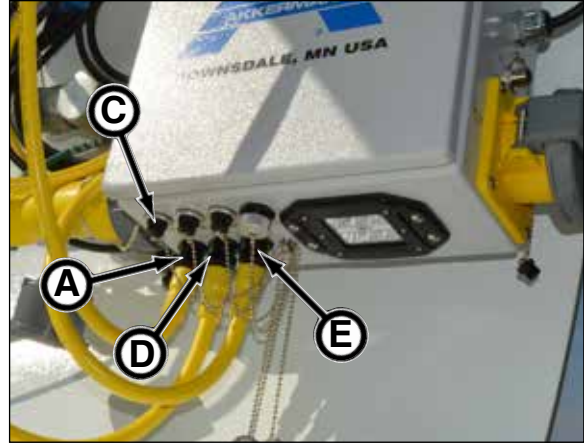

NOTICE

The standard configuration contains components (main monitor rack, flow meter, ten station boxes, 30 bentonite valves, power cables, communication cables, bentonite valve cables, and bentonite transducer pressure cables) for up to a 2,000 linear foot drive. The ABIS system setup can include less than ten station boxes in a 2,000 linear foot drive, but no more than ten station boxes. IJS components and cables are optional. Contact your Akkerman Aftermarket Support representative for more information.

NOTICE

If ground conditions cause water or soil to flow back into the automated bentonite injection valves, a pipe check valve must be installed. Failure to do so may damage automated injection valve.



(Continued on next page)

INSTALLING ADDITIONAL REMOTE STATION CONTROL BOXES IN PIPELINE

⚠ WARNING BEFORE disconnecting 120V power cable, the power **MUST** be shut down.

11. Disconnect remote station #1 control box communication cable from COMM IN connection (A) and install to the COMM IN connection (B) on the newly installed remote station 2 control box.
12. Disconnect the remote station #1 control box power cable 120VAC IN connection (C) and install to 120 VAC IN connection (D) on remote station 2 control box.
13. Install new communication cable from remote station 2 control box COMM OUT (E) to the remote station 1 control box COMM IN connection (F).
14. Install new power cable from remote station 2 control box 120 VAC OUT connection (G) to the remote station 1 control box 120 VAC IN connection (H).
15. Install cable connections from remote station control box to the automated bentonite injection valves (refer to steps 8 through 10 above).
16. As additional remote station control boxes are installed in the pipeline, repeat installation process as shown.

• **Cable Connections From Monitor To Remote Station Control Box #1**

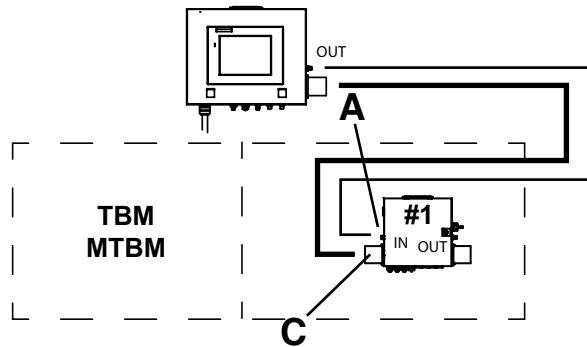

• **Cable Connections From Monitor To Remote Station Control Box #1 & #2**

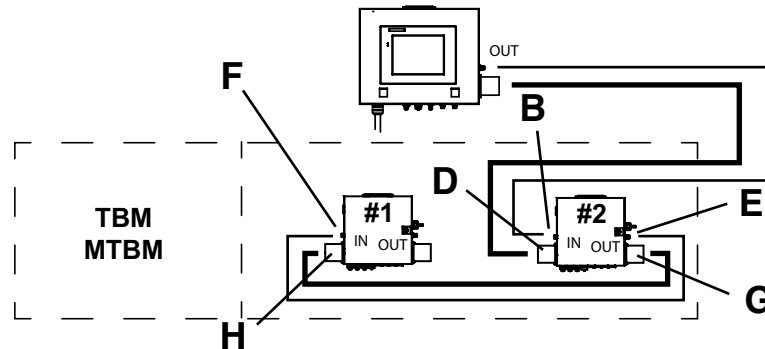

• **Cable Connections From Monitor To Remote Station Control Box #1, #2 ...**

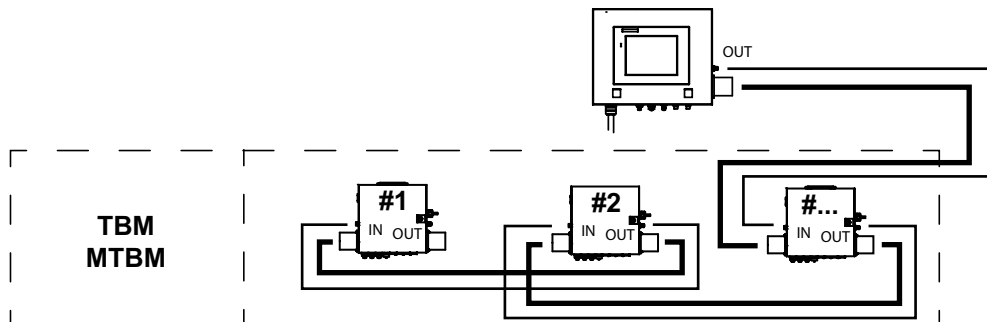

REMOTE STATION CONTROL BOX TO IJS STATION

If IJS Stations are used:



17. Connect cable from IJS PSI TRANS 10,000 connection (A) on monitor to IJS pressure transducer cable connection at the IJS pump.



18. Connect cable from IJS PSI connection (B) on remote station control box to IJS pressure transducer cable connection at the IJS station.
19. Connect cable from IJS POSITION connection (C) on remote station control box to IJS linear transducer cable connection at the IJS station.
20. Connect cable from IJS CONTROL VALVE connection (D) on remote station control box to IJS control valve connection at the IJS station.
21. As additional IJS Stations are added, repeat steps 17 through 20.

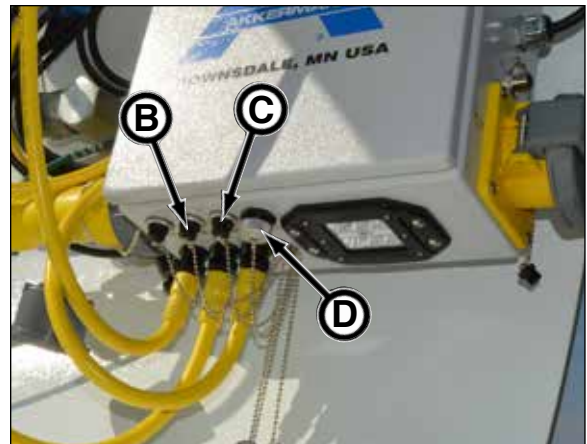

INSTALLING BENTONITE HOSES

1. Install bentonite return hose(s) from bentonite pump to return connection(s) (A) on the control station.
2. Install bentonite supply hose(s) from bentonite pump to supply connection(s) (B) on the control station.
3. Install bentonite supply hose to the Out Of Tunnel connection (C) on the control station. Install the other end of hose to the bentonite supply tunnel hose. Connect hose from tee fitting from bentonite supply tunnel hose to the automated bentonite valves.

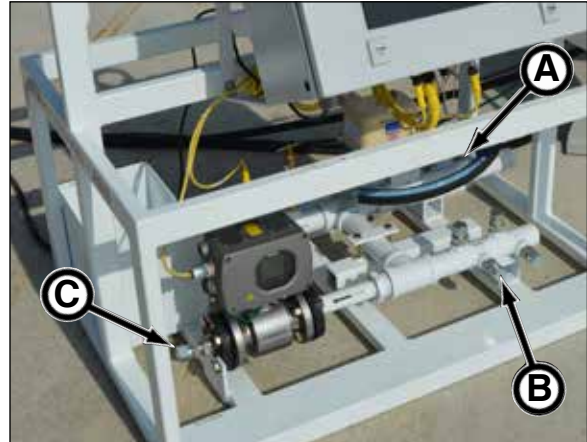

NOTICE

If ground conditions cause water or soil to flow back into the automated bentonite injection valves, a pipe check valve (D) must be installed in the tunnel bentonite injection ports. Failure to do so may damage automated injection valve.

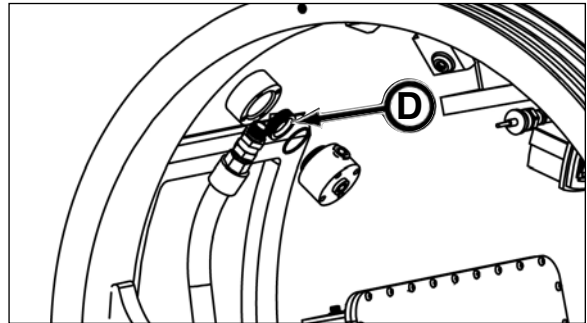

SETTING UP THE VALVE SEQUENCE

The Valve Sequence Setup screen arranges the automated order of the bentonite supply to the bentonite injection valves in the tunnel.

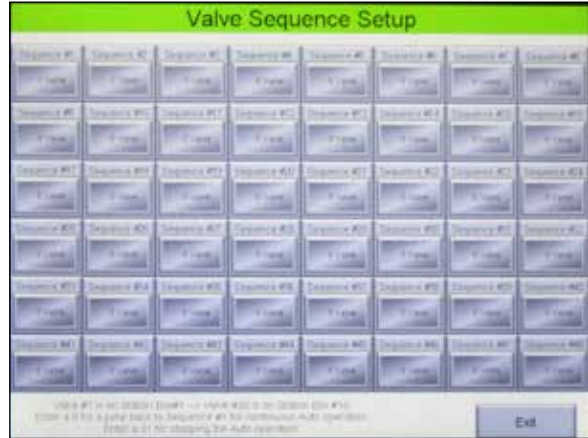

When setting up the valve sequence, keep in mind, there can be up to three automated bentonite injection valves connected to each station box (Valve A, Valve B and Valve C cable connections). Therefore when setting up the valve sequence:

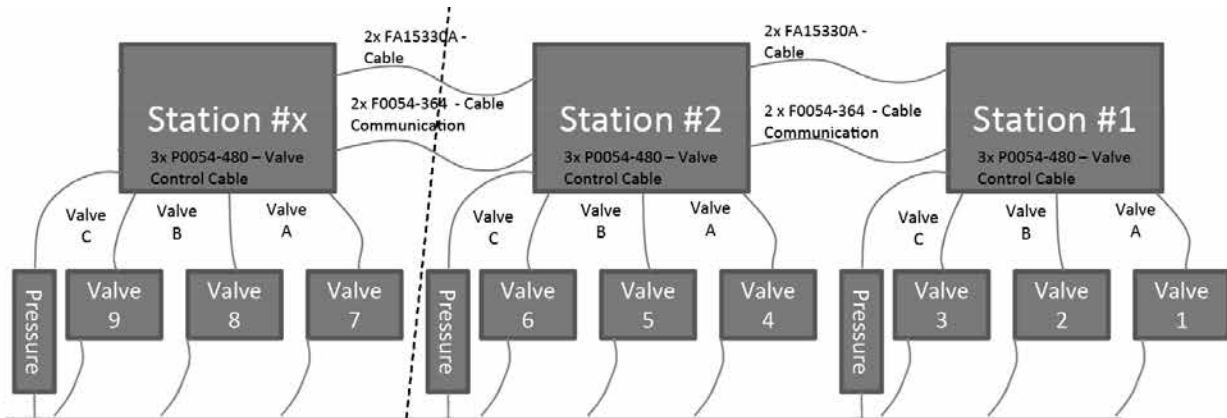

- Valves **1** (to Box Valve A), **2** (to Box Valve B) and **3** (to Box Valve C) are assigned to Station Box #1
- Valves **4** (to Box Valve A), **5** (to Box Valve B) and **6** (to Box Valve C) are assigned to Station Box #2
- Valves **7** (to Box Valve A), **8** (to Box Valve B) and **9** (to Box Valve C) are assigned to Station Box #3
- Valves **10** (to Box Valve A), **11** (to Box Valve B) and **12** (to Box Valve C) are assigned to Station Box #4
- Valves **13** (to Box Valve A), **14** (to Box Valve B) and **15** (to Box Valve C) are assigned to Station Box #5
- Valves **16** (to Box Valve A), **17** (to Box Valve B) and **18** (to Box Valve C) are assigned to Station Box #6
- Valves **19** (to Box Valve A), **20** (to Box Valve B) and **21** (to Box Valve C) are assigned to Station Box #7
- Valves **22** (to Box Valve A), **23** (to Box Valve B) and **24** (to Box Valve C) are assigned to Station Box #8
- Valves **25** (to Box Valve A), **26** (to Box Valve B) and **27** (to Box Valve C) are assigned to Station Box #9
- Valves **28** (to Box Valve A), **28** (to Box Valve B) and **30** (to Box Valve C) are assigned to Station Box #10

Valve Sequence Setup:

1. Once ABIS is powered up, the Bentonite Control Screen appears. Press Menu button (A).

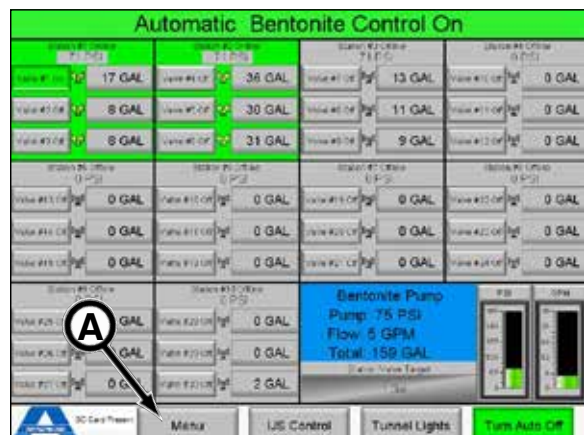

- The ABIS System Menu screen appears. Press Valve Sequence Setup button (A).

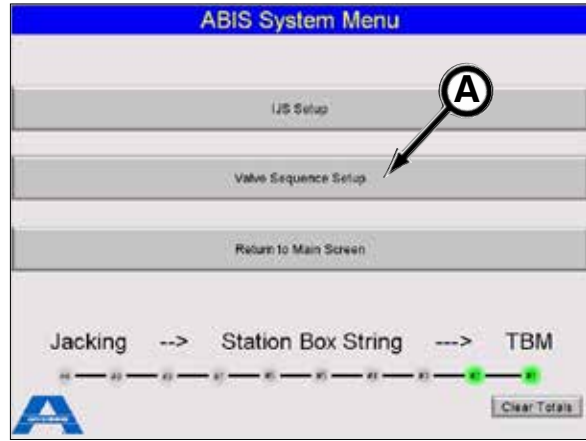

- The Valve Sequence Setup screen appears. The screen shows 48 sequence boxes allowing for multiple automated sequence options.

Setting Up Valve Sequence For Auto Operation

NOTICE This screen will setup the valve sequence for auto operation. To actually activate the auto valve sequence, click Exit (B) to return to the Bentonite Control Screen, and click the Turn Auto On button (refer to Using the Bentonite Control Screen in this section).

- Press the Sequence # 1 box (C) to display the numeric entry window (D).
- Press the valve number on the numeric entry keypad, in this case 1 and press ENT (E) to enter the number for sequence #1.
- Press the Sequence # 2 box (F) to display the numeric entry window.
- Press the valve number, in this case 2 and press ENT to enter the number for sequence #2.
- Continue adding the valve numbers per sequence order.
- Type a 0 (G) in the desired sequence box to jump back to Sequence #1 for continuous auto operation. Type 31 in sequence box to stop auto operation.
- Once sequence setup is complete, click Exit to return to the Bentonite Control Screen.

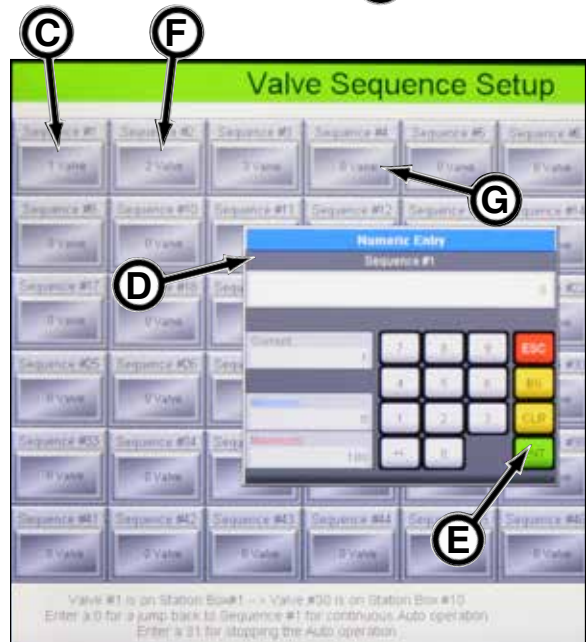

Example in the graphics above:

- the automated operation will start at sequence #1 - 1 Valve, proceed to Sequence #2 - 2 Valve, continue to Sequence #3 - 3 Valve. Since Sequence #4 has a 0 Valve, the auto operation will return to Sequence #1, which is 1 Valve and continue repeating the auto sequence.
- If a 31 is typed into the Sequence #4 box, the auto sequence operation will stop after the bentonite volume is pumped into 1 Valve, then 2 Valve and ending at 3 Valve.

NOTICE The Minimum and Maximum values are factory set.

PREPARING THE ABIS SYSTEM FOR OPERATION

Before operating the ABIS system, complete the following procedures:

1. Assemble the ABIS system (refer to Assembling the ABIS System in this section).



2. Install bentonite hoses from the bentonite pump to the ABIS system and bentonite tunnel valves (refer to Installing Bentonite Hoses in this section).



3. Plug in the ABIS system 120 VAC power cord to 120 VAC supply.

4. With the monitor on, setup the automated sequence operation of the bentonite injection valves (refer to Valve Sequence Setup in this section).

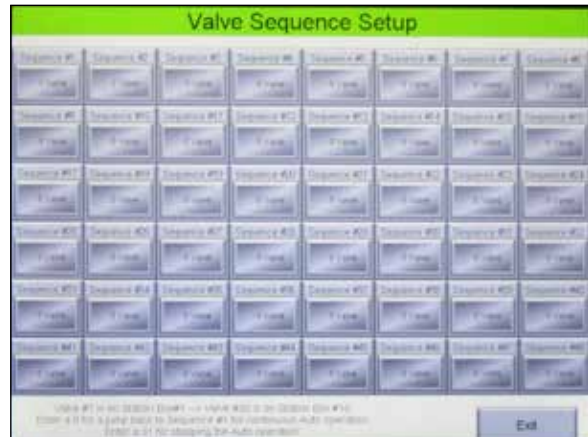

5. Setup the station valve target bentonite volume (A); the amount (gallons) of bentonite pumped to each sequenced valve into the pipe annulus when the automatic bentonite control is on. The amount of bentonite is typically provided with the engineering project data requirements.

- The target amount can be changed by simply pressing the Gal button (A), updating the gallon amount on the numeric entry window and press ENT.

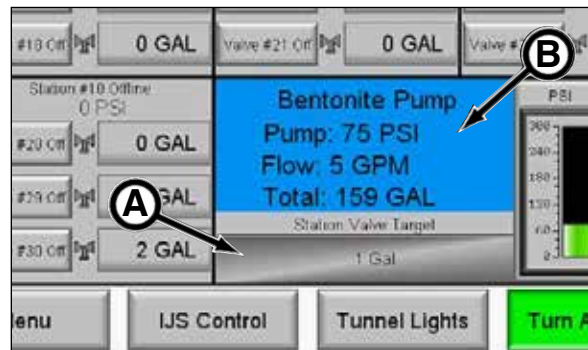

6. Check the bentonite pump for proper operation. Check the bentonite pump flow and pressure (B) on the Automated Bentonite Control screen.
(continued on next page)

7. Test the tunnel lights with the Tunnel Light Control Screen (refer to the Using The Tunnel Light Control Screen in this section).

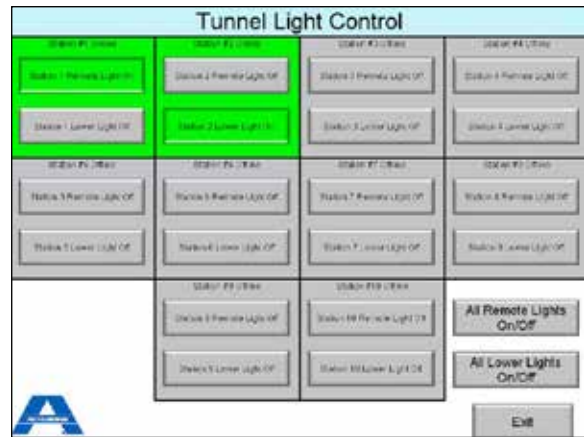

8. (If needed) Setup the IJS station control to adjust the desired cylinder extension pressure and enable the IJS stations (refer to Setting Up The IJS Stations in this section).

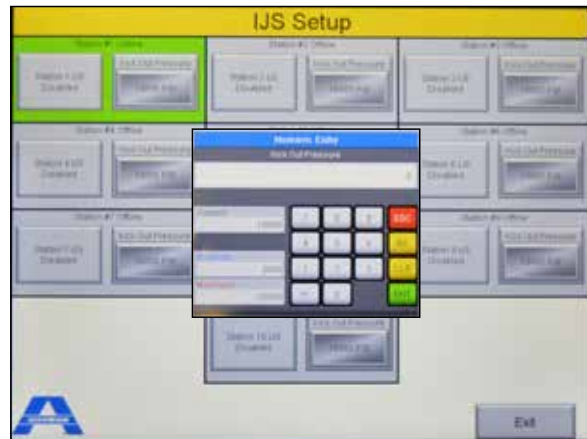

9. Test the IJS cylinder pressure and linear transducer readings on the IJS Control screen

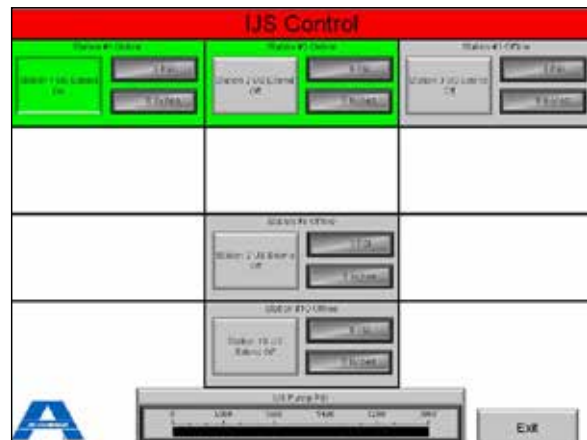

10. If starting a new drive, clear logged data by pressing the Clear Totals button (A) on the ABIS System Menu Screen.
11. Check the ABIS System Menu screen to verify the online station boxes (B) (green) and offline station boxes (C) (gray).

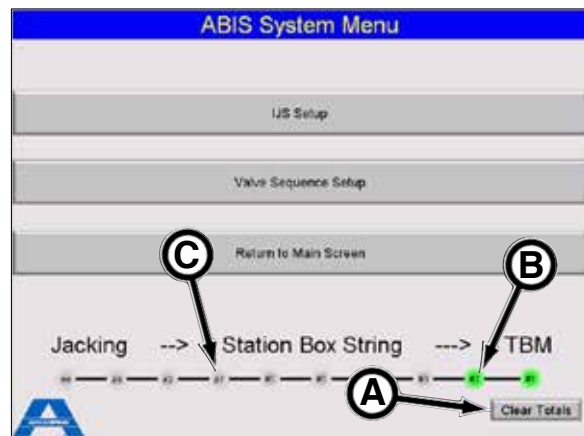

OPERATING THE ABIS SYSTEM

1. Prepare the ABIS system (refer to Preparing The ABIS System For Operation in this section).



2. Be sure the Station Valve Target (A) volume amount is properly set (refer to step 5 in Preparing The ABIS System For Operation in this section).

3. Start bentonite pump. Check the bentonite pump flow and pressure (B) on the Automatic Bentonite Control screen for proper connection and operation.

4. With the bentonite pump properly connected and operating, press Turn Auto On/Off button (C) to the On (green) position.

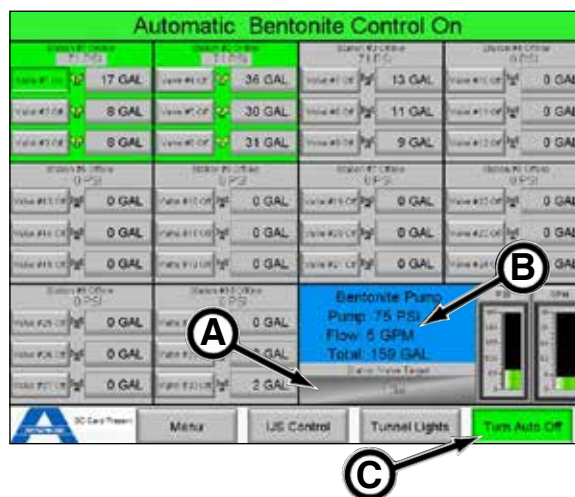

NOTICE If manual operation is desired, refer to Operating The ABIS System in Manual Mode in this section.

5. The ABIS system will automatically pump the station valve target bentonite volume (A) of bentonite into the automated bentonite injection valves based on the valve sequence setup.

If the valve sequence is setup for continuous auto operation, the ABIS system will continue pumping bentonite until the operator stops the auto operation.

If the valve sequence is setup for stopping the auto operation, the ABIS system will perform the automated sequence once and then stop the auto operation.

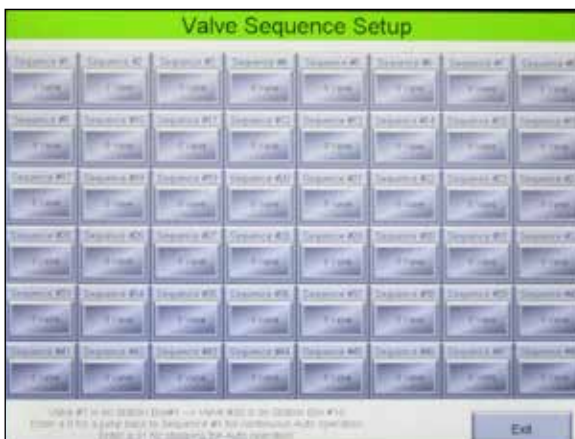

6. During auto operation, be sure to periodically check the bentonite pump tank level. Do not run pump dry. Doing so will cause damage to components.

7. When adding new pipe and utilities, refer to Adding New Pipe & Utilities in this section.

8. To stop pumping bentonite to injection valves, press Turn Auto On/Off button (D) to the off (gray) position.

9. Perform daily shutdown procedure (refer to Daily Shutdown in this section).

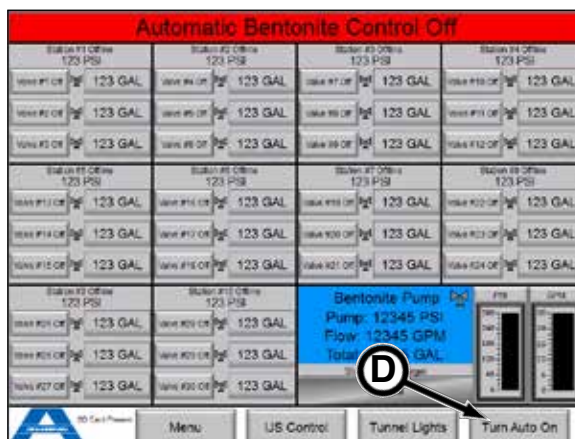

OPERATING THE ABIS SYSTEM IN MANUAL MODE

To operate the ABIS system in manual mode:



1. Press the Turn Auto On/Off button (A) to the off position. When the automatic bentonite control is off, the header (B) will change from green to red while the header Automatic Bentonite Control text changes from On to Off.
2. Press the desired bentonite injection valve button (C) for individual operation provided the station box is online (D) (also displayed in green) and the bentonite pump is in operation. The selected valve button color will change from gray to green indicating the valve is on.

IMPORTANT: In manual mode, bentonite will continue to pump to the selected injection valve until the valve is pressed to the off position. The Station Valve Target (E) amount is irrelevant when operating in manual mode.

3. Once a valve is pressed on for manual operation, the selected valve icon (F) will indicate that the valve is in operation. The volume dispensed will be added to the valve total (G) and the total accumulated gallons (H).
4. When complete, press the operating valve to the off (gray) position.

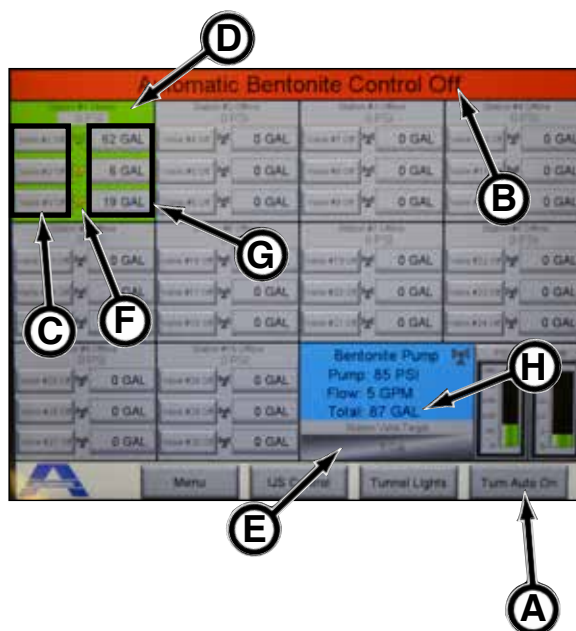

CONTROLLING THE TUNNEL LIGHTS

The remote work lights (A) and the tunnel lights (B) can be controlled at the ABIS monitor on the Tunnel Light Control screen.

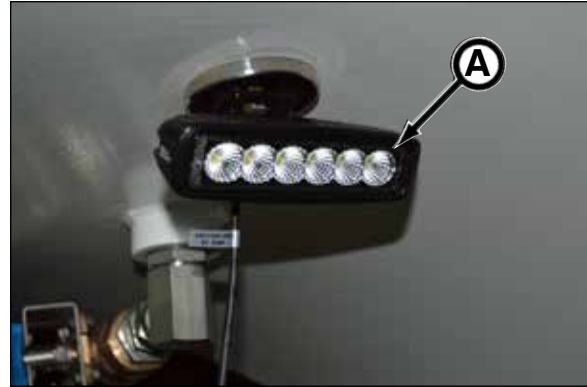

Remote Work Light

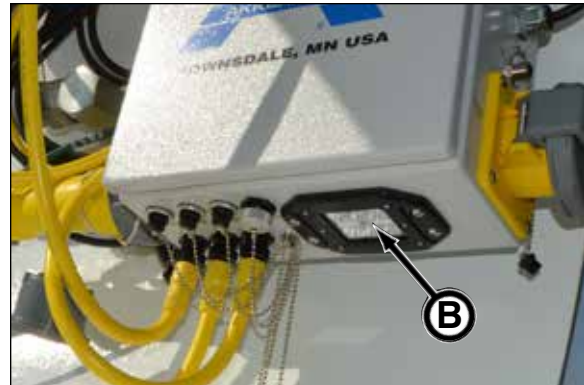

Tunnel Light (Lower Light)

When a station box is online, the remote work lights and the tunnel lights (lower light) can be controlled by pressing the desired light Remote light button (C) and/or Lower Light (Tunnel Light) button (D) on or off.

If multiple station boxes are online, the remote work lights and the tunnel lights (lower light) can all be controlled by simply pressing All Remote Lights On/Off button (E) and/or All Lower Lights On/Off button (F).

Press Exit button (G) to return to the Automatic Bentonite Control screen.

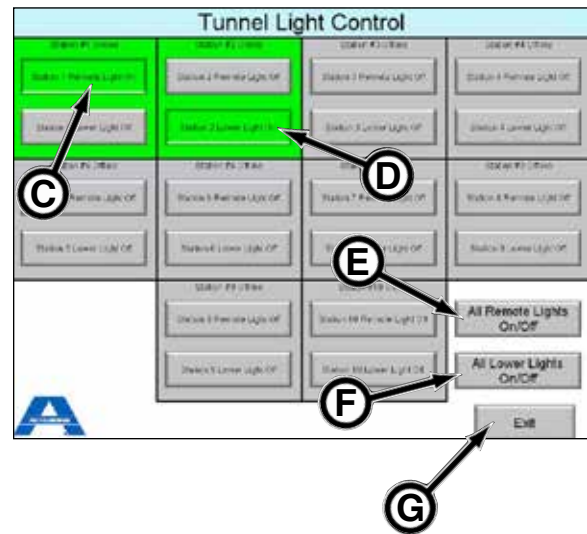

COLD WEATHER OPERATION

Freezing temperatures during the tunneling process, creates the necessity to prepare the site and equipment for the cold weather. Failure to do so will cause damage to components and supporting equipment.

There are various methods of keeping equipment from freezing:

- Tent working areas with a heating system when possible.
- When working with water, the water needs to be constantly circulated to prevent freezing. Otherwise the equipment must be drained and/or treated with a RV anti-freeze solution to prevent freezing.
- If the bentonite pump will be shut off for a considerable length of time and the temperature is at or below freezing, the fluid must be drained or treated with RV anti-freeze.
- Water tanks must be drained or treated with RV anti-freeze.
- Drain hoses to prevent freezing and keep low areas properly drained to prevent freezing damage.
- For all equipment, use proper lubricant based on ambient temperature to prevent damage.
- Use compressed air to purge a system of water. Be sure the discharge valve is open before doing so.
- Install heaters for hydraulic systems.



If systems were shut down for freezing weather, be sure to start systems slowly and let them run for at least five minutes to allow for warm up and in the case of a pump, to displace any surface ice that may have accumulated in the fluid before going back to full operation mode.

Remember it is also critical to keep the work site safe and employees comfortable during the freezing weather. Good training, supervision, proper clothing and limiting personal exposure to the weather is essential for keeping personnel and equipment safe on the job site.

ADDING NEW PIPE & UTILITIES

Once the MTBM is advanced far enough, additional pipe and utilities (main cutter drive cable, head power cable, booster pump cable, ethernet cable, tunnel light cable, slurry feed hose, slurry return hose, ventilation lines, bentonite supply hose, high pressure jetting hose, and other utilities) must be added to the existing pipeline, tunnel cables and hoses.

⚠ WARNING Suspended loads may fall and cause severe injury or death. Do not allow anyone to enter area under or around a suspended load.

⚠ DANGER Contact with severed electrical cables, damaged cable connections, or dirt in the cable connections WILL cause severe injury or death.

Constantly inspect electrical cables during the jacking process to prevent cutting or stretching of any electrical cables.

1. Refer to your tunneling equipment manuals for proper procedures on adding new pipe and utilities.
2. On the Bentonite Control screen, press Turn Auto On/Off button (A) to the off position.
3. Shut down the bentonite pump (refer to your bentonite pump manual for proper shut down procedures).
4. Shut down power to ABIS system.
5. Disconnect the ABIS communication cable and 120 VAC incoming power cable, and utilities (electrical cable, hoses, etc.) between the jacking frame and the tunneling machine/pipe.

NOTICE When disconnecting cable connections to add a new pipe section to the tunnel, operators must power down all electrical feeds to the tunnel. Electrical cabling must be disconnected first and slurry pipes last to prevent slurry water from getting the cables wet. Refer to your tunneling equipment manuals for procedures to disconnect utilities and add new pipe.

Be sure all the cables and hose connections are in a clean, dry location and out of the way of the next pipe. When walking the tunnel with a cable, always hold connection ends up so water is not kicked up into the connection ends.

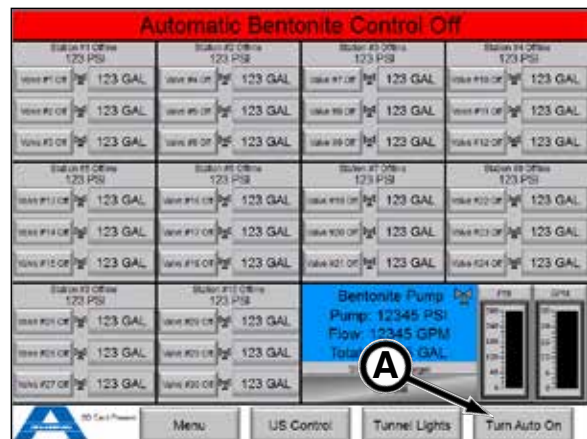

DAILY SHUTDOWN

Perform the following daily shut down procedures:

1. On the Automatic Bentonite Control screen, press Turn Auto On/Off button (A) to the off (gray) position.
2. Shut down the bentonite pump (refer to your bentonite pump manual for proper shut down procedures).
3. Shut down 120 VAC power to ABIS system.
4. If the ABIS must be removed for security, moisture or other reasons:
 - carefully remove cables and hoses from the system.
 - collect the cables and hoses, and place them in a safe location where they will not be damaged or subjected to moisture.
 - carefully remove the ABIS system control station and monitor. Store in a secure location and if possible, in a climate controlled environment.
5. If freezing weather is present, refer to Cold Weather Operation in this section.



DATA LOGGING

The ABIS system automatically generates daily data logging files for various ABIS operations and alarms. The data logging files show the ABIS system operations with the date and time of the following: total gallons delivered at each valve, total accumulated delivered gallons of all valves, bentonite pressure at each remote station control box, and the IJS pressure and position at each IJS station pressure and linear transducers. For logged alarms, refer to System Message Notifications in this section.

To view or print out the data logging information:

1. Carefully remove the SD card from the monitor memory card slot (A).

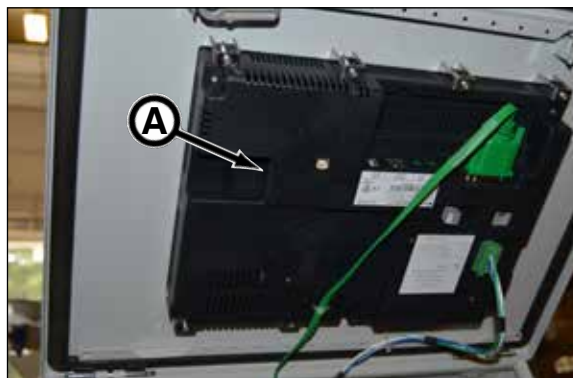

2. Install a card reader (B) into a computer.
3. Insert the SD card (C) into the card reader.

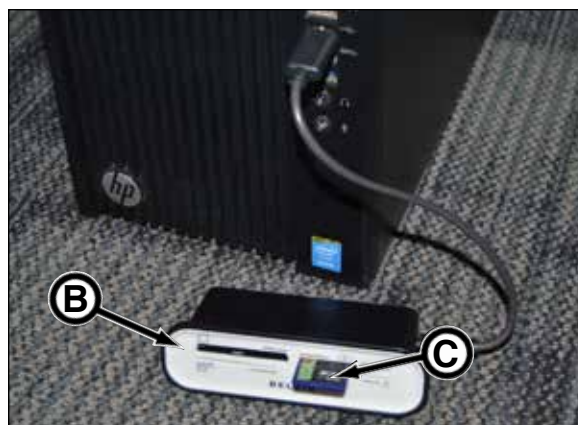

4. A new drive will appear on the screen of your computer. This is the SD card you just installed.
5. Navigate to the SD card drive and double click Log folder (D).
6. Open a spreadsheet program such as Microsoft® Excel®.



7. Open the desired .txt data file (do not open the .log files):
 - Data Log_Station1-5_Totals_datecode.txt
 - Data Log_Station6-10_Totals_datecode.txt
 - Data Log_Bentonite_Pressures_datecode.txt
 - Data Log_IJS_1-5_Info_datecode.txt
 - Data Log_IJS_6-10_Info_datecode.txt

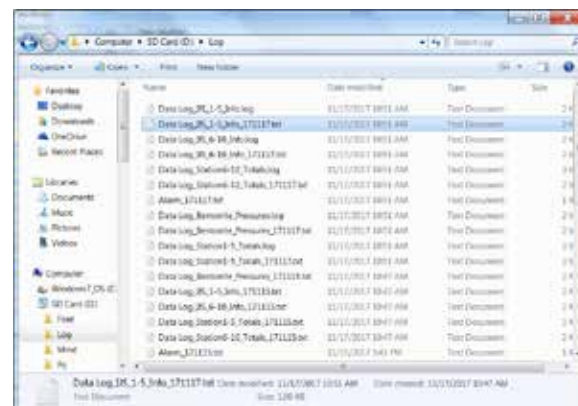

NOTICE When navigating to files, you may have to select All Files to display the .txt data files.

(continued on next page)

8. After selecting a .txt data file, the text import wizard (Microsoft Excel) window (A) will appear.

9. In the text import wizard window, be sure to select the Delimited file type (A). The delimited file type will import the information from a text file and split up the various pieces of information into separate columns and name each column with an appropriate header.

10. Click Finish button (B).

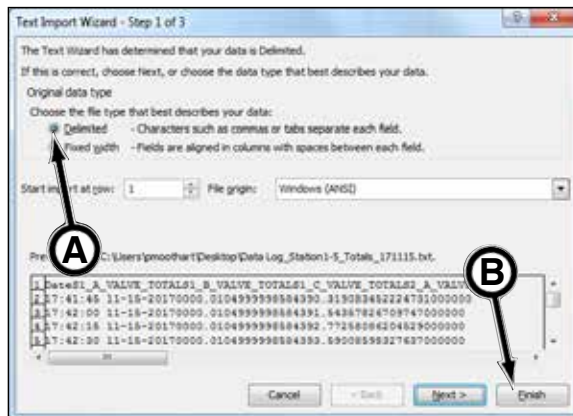

11. The data file appears in column format. Reformat the columns as needed for your report.

12. Repeat steps 5 through 11 with the other data logging files.

13. Once completed, eject the SD card and remove the card reader from the computer.

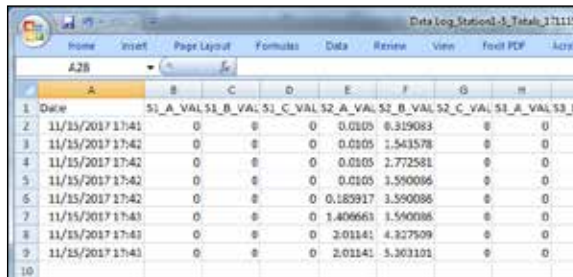

14. Carefully reinstall the SD card into the memory card slot in the monitor.

15. Close card cover door.

16. Close and secure monitor cover.



17. The logged data files are created daily. Therefore when reinstalling the SD card, any additional data logged will be added to the existing data files per day. When starting a new day, the new data files will be created in the Log folder with files containing accumulated volume totals carrying over from the previous day to the new day.

If at anytime the logged data should be reset, press the Clear Totals button (C) on the ABIS System Menu screen. To confirm the clearing of the logged totals, press the Yes button (D). The existing file totals are reset to zero.

Clearing totals is typically performed prior to each job launch.

NOTICE Be sure to periodically backup data files (refer to 14. Backup Data Logging Information in section 9, Periodic Maintenance section).

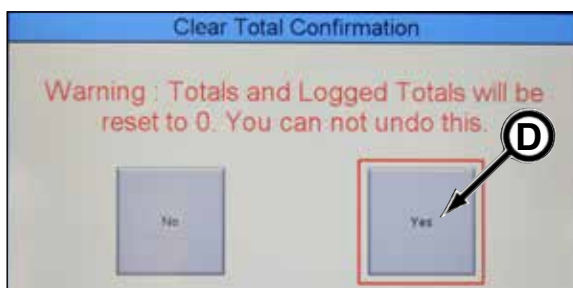
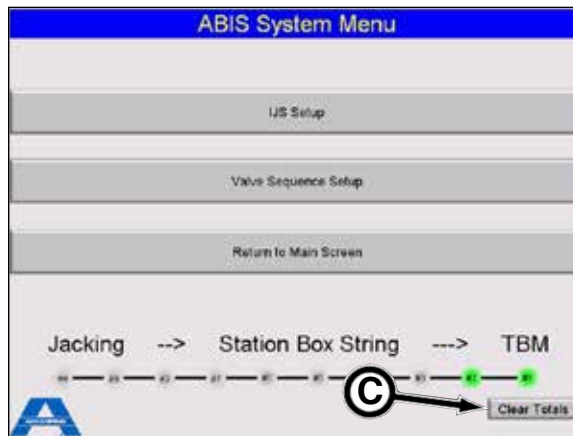

SYSTEM MESSAGE NOTIFICATIONS

System message notifications will be displayed as they occur.

Initially a notification window (A) will appear alerting that the operator must acknowledge the notification before being able to proceed with the operation of the ABIS system.

The system notification will periodically reappear in the top banner (B) of the ABIS system monitor screen. Once the notification has been resolved, the notification will no longer appear in the top banner.

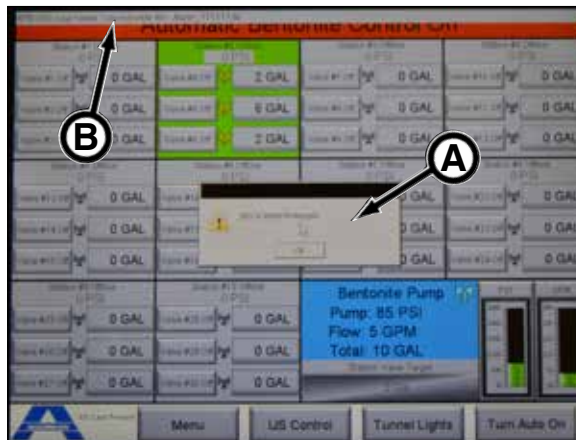

NOTICE The system message notifications are logged in the Alarm_datecode.txt (C) file in the Log folder on the SD card.



ABIS System Message Notifications:

• **Detecting SD1 for logging data.....**

- This message occurs when the SD card is either not installed in the computer or the card is not recognized. A SD card must be installed into system to capture any logged data. Press Ignore button (D) to clear notification. Be sure to install SD card before continuing ABIS operation.

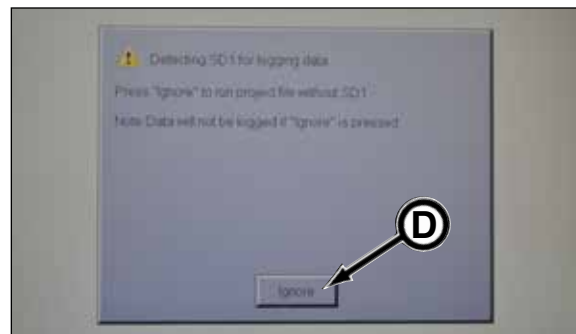

NOTICE A SD Card Present or No SD Card messages (E) appear on the Bentonite Control Screen when the SD card is/is not installed.

• **SD1 is Write Protected**

- This message occurs when the SD card is locked or write protected. Press OK button (F) to clear notification. Be sure to remove SD card and unlock the card and reinstall card before continuing ABIS operation.

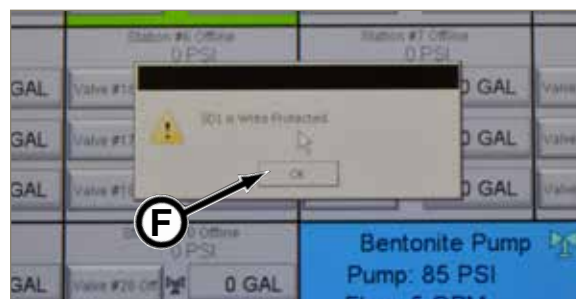
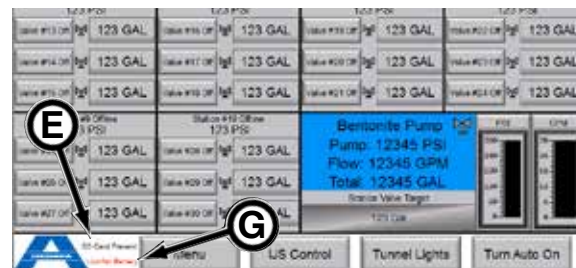

NOTICE A Low/No Battery message (G) appears on the Bentonite Control Screen when the backup battery power is low or the battery is not installed.

CONNECTING ABIS SYSTEM TO AKKERMAN MICRO. CONTROL CONTAINER

1. Connect ethernet cable from ABIS monitor HMI Ethernet connection (A) to bulkhead connection on control container. This connection allows the control container operator to view and create ABIS data reports from the control container console.

NOTICE

Connect ethernet cable from ABIS monitor MTBM Ethernet IN connection (B) to Boring Head Ethernet connection on the control container bulkhead. This connection combines the ABIS and MTBM tunnel ethernet so there is only one ethernet cable in the tunnel.

NOTICE

To connect to other manufacturer's equipment, contact your Akkerman Aftermarket Support representative.

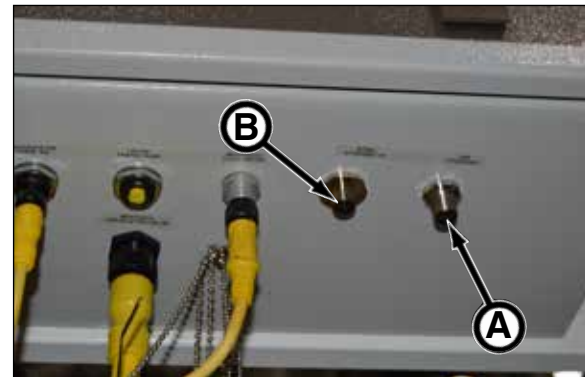

2. Use the Report Generator program in the control container to select the ABIS data variables for your report. Save, view and/or print your ABIS data from the program. Refer to Using The Report Generator in your Akkerman Microtunneling System Operator's Manual.

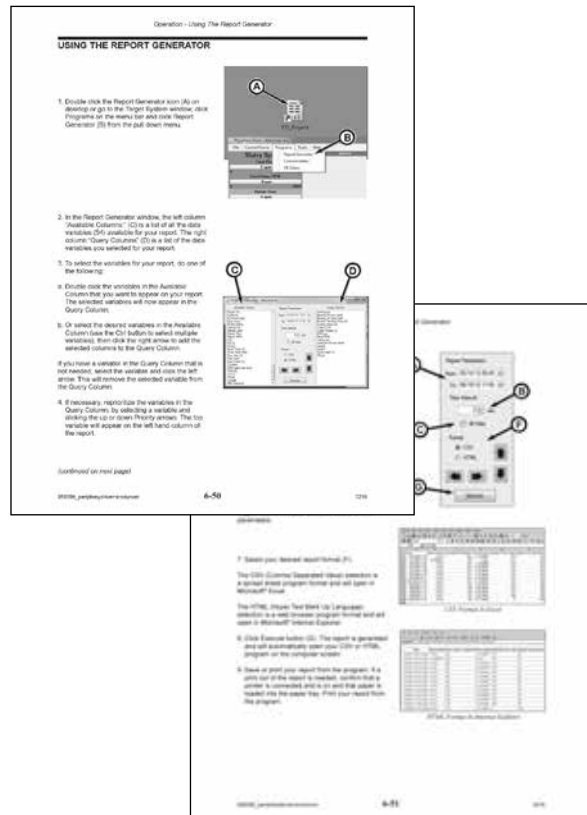

SETTING UP THE IJS STATIONS (IF EQUIPPED)

The IJS Setup screen sets the hydraulic pressure at each online IJS station.

To adjust the IJS hydraulic pressure:

1. Press the Kick Out Pressure button (A). A numeric entry window (B) will appear.
2. Type in the desired hydraulic pressure using the numeric keypad (C), then press ENT (D) (enter).
3. To enable/disable the IJS station, press the desired Station # box (E). The desired station # box must be enabled on this setup screen to provide power to the IJS cylinder control at the IJS station.
5. Press Exit button (F) to return to the Bentonite Control screen.

NOTICE The Minimum and Maximum hydraulic pressure values are factory set.

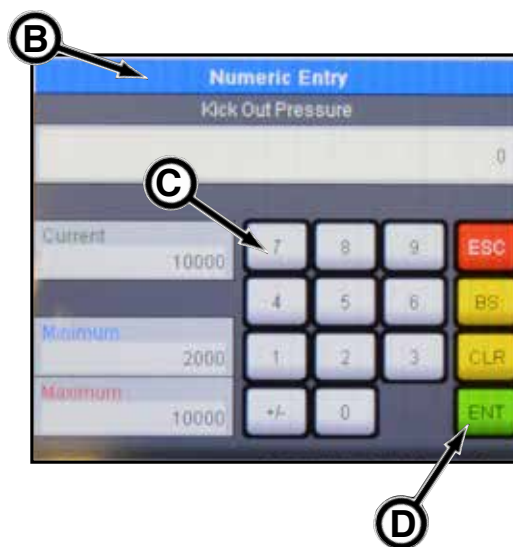
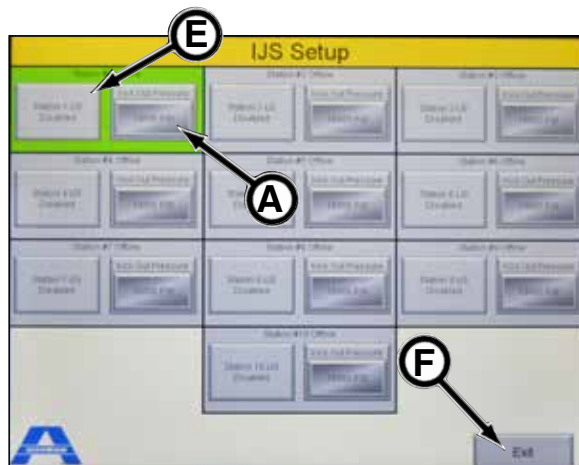

Operation

NOTES

Transporting

TRANSPORTING GUIDELINES

1. Know the local, state, and federal transportation regulations.
2. Obtain required permits for transporting.
3. Remove any obstacles from the trailer floor.
4. Clean debris from equipment.
5. Clean bentonite/lubricant from:
 - hoses
 - supply and return lines
 - manifolds
 - bentonite injection valves
6. BEFORE lifting equipment, the equipment lifting eyes and sling must be inspected for damage before lifting.
7. Load and unload on level ground.
8. Securely fasten the ABIS control station to trailer floor. If transporting ABIS control station with monitor installed, be sure monitor is securely fastened to the control station.

NOTES

Lubricants

Use of inferior lubricants will affect the efficient performance of your tunneling equipment. Always use high quality lubricants.

NOTES

Periodic Maintenance

⚠ WARNING Review the Safety section in this manual and your tunneling equipment manual before performing maintenance. Failure to do so, could cause severe injury or death.

LOCKOUT POWER BEFORE SERVICING

⚠ WARNING Severe personal injury or death can result from unexpected power pack start-up or machine movement.

LOCKOUT power before attempting to make repairs or adjustments to this equipment, unless otherwise indicated. Proper lockout will prevent accidents and save lives. Performing the lockout will also prevent the equipment from moving or operating unexpectedly.



AVOID PINCH POINTS

⚠ WARNING Moving parts or the mishandling of parts can cause severe personal injury.

Keep hands away from moving parts.

Watch your fingers, hands, and legs while equipment is in operation.

Handle parts carefully to avoid crushing and pinch point hazards.

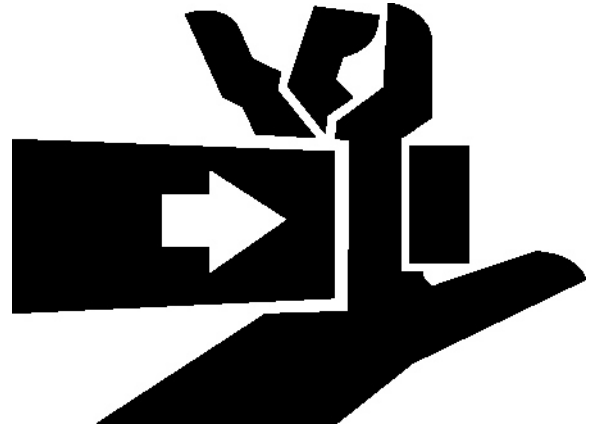

WELDING

UNAUTHORIZED WELDING

⚠ WARNING Unauthorized welding can cause structural failure and computer system damage.

Do not weld on any structural member. Unauthorized welding or repair will void the warranty.

WELDING ON STRUCTURE

NOTICE Welding on structure will damage the structure and other computer system components.

Contact your Akkerman Aftermarket Support representative BEFORE welding for approval and proper welding procedures. Failure to receive authorized welding, will void the warranty and cause damage to electrical components.

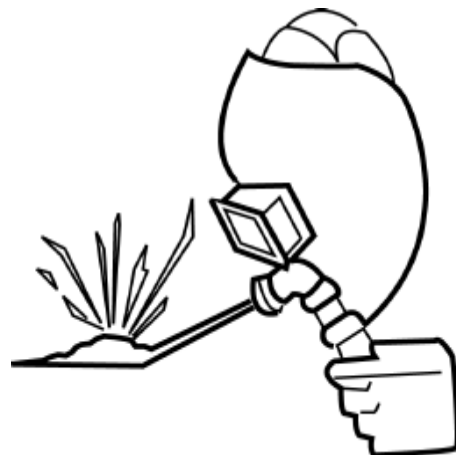

MAINTENANCE CHARTS

NOTICE Use the item number in the chart to refer to the detailed maintenance procedures later in this section.

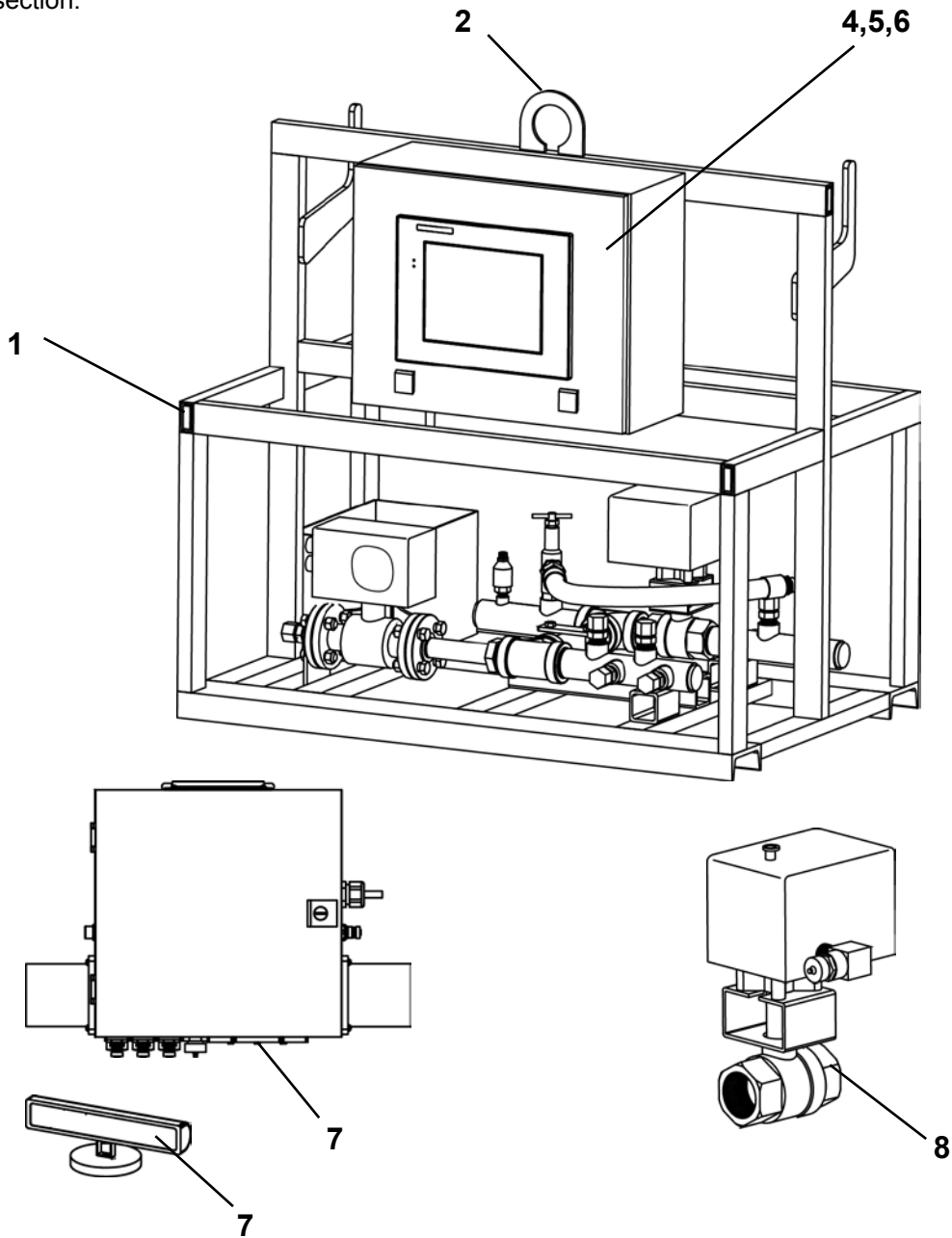

PRIOR TO EACH JOB LAUNCH

ITEM	COMPONENT	SERVICE	REFERENCE
1.	Structure	Inspect	If damaged, repair or replace with new.
2.	Lift Eye	Inspect	
*3.	Cables & Hoses	Inspect & Clean	Replace if damaged. Connections: securely fastened.
4.	ABIS Computer	Check Operation	CR2354 Battery For data logging.
5.	Backup Battery	Install	
6.	SD Card	Install	
7.	Lights	Check Operation	
8.	Injection Valves	Inspect & Clean	

* Not Shown

NOTICE

Use the item number in the chart to refer to the detailed maintenance procedures later in this section.

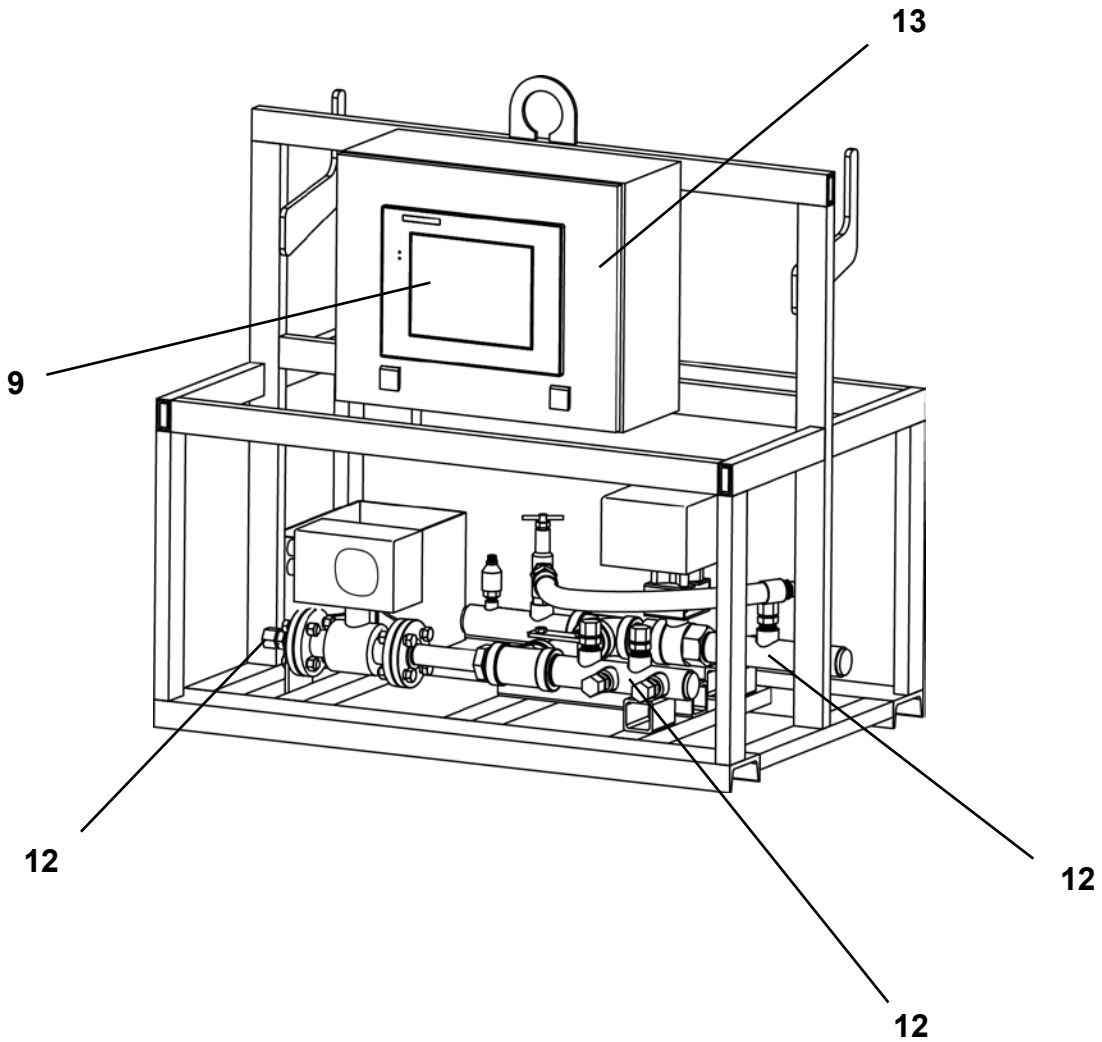

DAILY OR EVERY 10 HOURS OF OPERATION

ITEM	COMPONENT	SERVICE	REFERENCE
9.	Monitor Screen	Clean Display	Keep dry & clean. Repair or replace as needed. If damaged, replace with new. In freezing weather.
*10.	Cables	Inspect & Clean	
*11.	Decals	Inspect	
12.	ABIS System	Flush & Drain	
13.	Control Data	Backup Database	

* Not Shown

NOTICE Use the item number in the chart to refer to the detailed maintenance procedures later in this section.

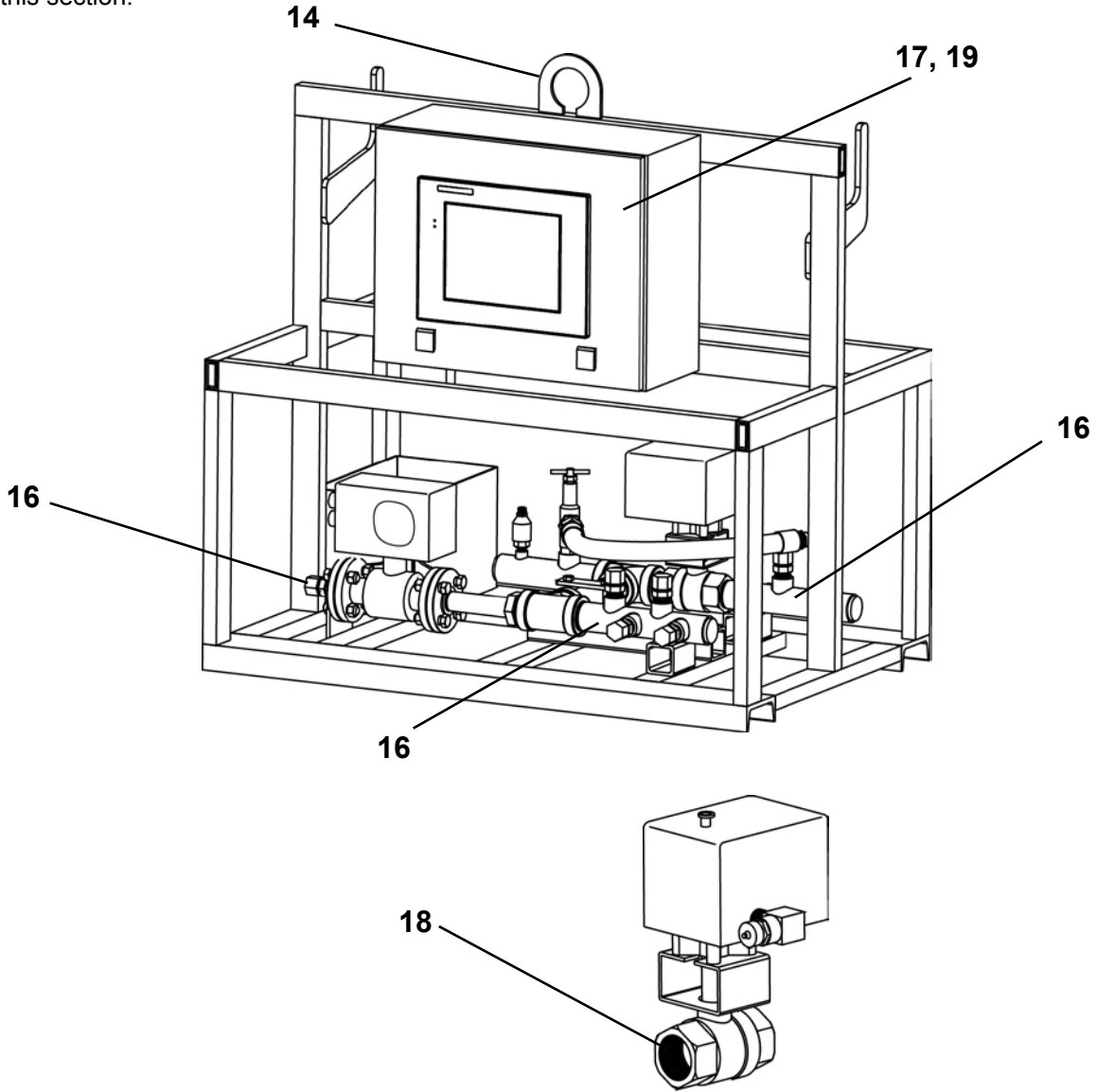

COMPLETION OF EACH DRIVE

ITEM	COMPONENT	SERVICE	REFERENCE
14.	Lift Eye	Inspect	If damaged, repair or replace with new.
*15.	Cables & Hoses	Inspect & Clean	
16.	ABIS System	Flush & Drain	
17.	SD Card	Remove & Backup	
18.	Injection Valves	Clean	

* Not Shown

ANNUALLY

ITEM	COMPONENT	SERVICE	REFERENCE
19.	Backup Battery	Replace With New	CR2354 Battery

PRIOR TO EACH JOB LAUNCH

1. INSPECT STRUCTURE

Check ABIS structure for cracks, wear or other damage.

If damaged, repair as needed prior to operation.



2. INSPECT LIFT EYE

Before lifting ABIS system, check lift eye (A) for damage. A worn or damaged lift eye **MUST** be replaced before lifting the ABIS system.

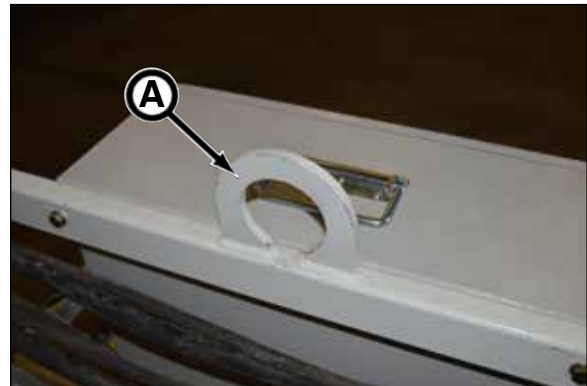

3. INSPECT CABLES & HOSES

1. Inspect hoses and cables for cracking, fraying, wear or damage. Repair or replace as needed.
2. Be sure cables and hoses are securely fastened to connections.

NOTICE

Keep cables clear of debris, water and fluids. Before connecting power cables, clean all connections with a non oil-based electric contact cleaner. Do not use electric contact grease since it tends to collect dust and dirt.



4. CHECK COMPUTER OPERATION

Once the 120V power cable is installed and the 120V power is energized, the ABIS computer system will automatically start up.

1. With the Automatic Bentonite Control screen active, press an online valve (A) to check to see if:
 - the circulation valve on the control station is operational
 - the selected injection valve is operational

If valves do not operate, troubleshooting will be required before operating.

2. Navigate to the Valve Sequence Setup screen. Check to be sure the valves on the online remote station boxes are shown in the sequence boxes on the setup screen.

3. Navigate to the IJS Setup screen (if used). Press IJS Setup. Check to be sure the online IJS stations are shown as online (green) on the setup screen.

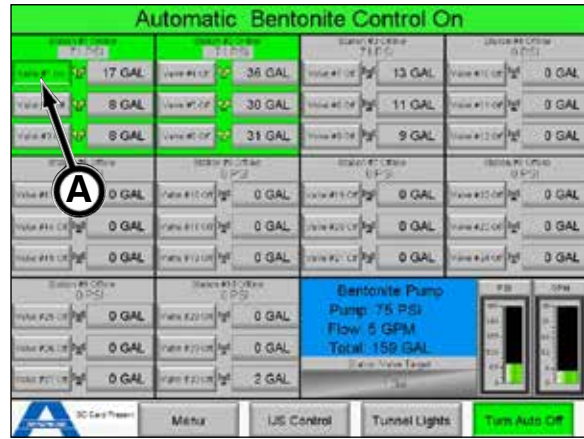

5. INSTALL ABIS SYSTEM BACKUP BATTERY

Install ABIS system backup battery to ensure that any data collected will not be lost during power disruption.

1. Shut off the 120V power to the ABIS system.
2. Open monitor front cover.
3. On the PLC unit (A), locate battery door (B).
4. Press the retaining clip (C) on the battery door (B) and swing the door open.
5. Install a new CR2354 battery (D) into the coin-type slot with the +, or flat side out.
6. Close the battery door so that it locks securely.
7. Make a note of the date the battery was installed. The battery backup is now available.
8. Close and secure the monitor cover.

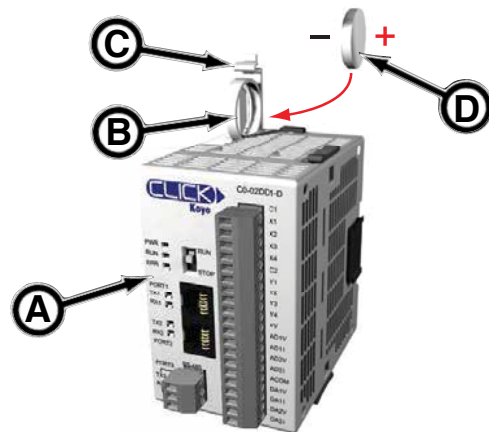
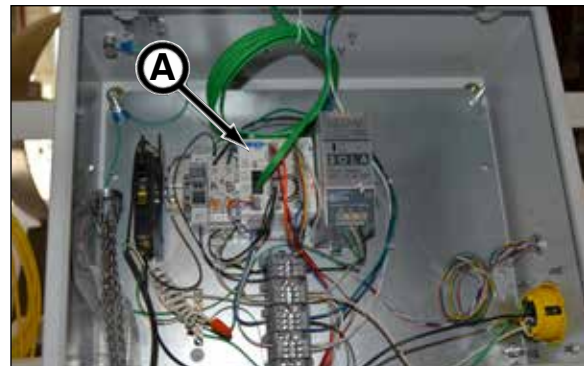

NOTICE A Low/No Battery message appears on the Bentonite Control Screen when the backup battery power is low or the battery is not installed.

6. INSTALL SD CARD

Install SD card into computer to save the data logging information.

1. Shut off 120V power to the ABIS system.
2. Open monitor front cover.
3. Press memory card cover door (A) to open.

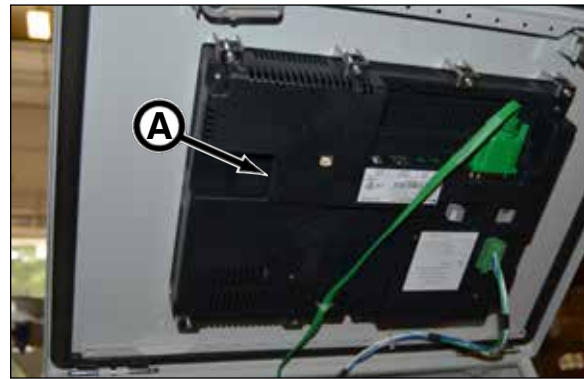

4. Swing door open and orient card as shown on housing and push SD card into slot until it clicks into place.
 - SD Card Requirement:
 - SD card: 2 GB max.
 - SDHC card: 32 GB max.



NOTICE Before installing SD card, be sure the tiny switch on the side of the card is to the unlock position. A locked card prevents any data from being recorded or erased.

NOTICE Do not touch the gold contacts on the back of the SD card. Finger oils and moisture can corrode the contacts or leave a film that will not conduct properly. Store SD card in a protective case when not in use.

5. Close card cover door.
6. Close and secure monitor cover.



7. When the SD card is installed and the ABIS system powered up, the SD Card Present message (B) will appear on the Bentonite Control screen.

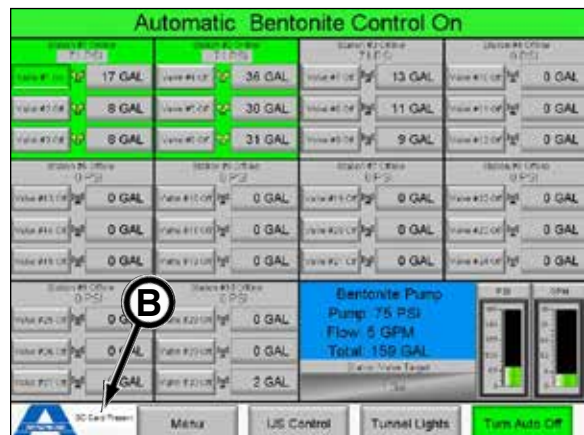

7. CHECK LIGHT OPERATION

Check tunnel and working lights as follows:

1. With power on to ABIS system and at least one remote station box connected to the monitor connections on the control station, navigate to the Tunnel Lights screen.
2. Check tunnel lights (A) by pressing the Station # Lower Light button (B) on each online station box.
3. In addition, check the tunnel lights with the All Lower Lights On/Off button (C).
4. Check working lights (D) by pressing the Station # Remote Light button (E) on each online station box.
5. In addition, check the working lights with the All Remote Lights On/Off button (F).
6. If any of the lights fail to function properly, check all cable connections from control station to remote station boxes.
7. Check light cables for wear or damage. If cables show signs of wear or damage, repair or replace.
8. Press Exit button (G) to return to the Automatic Bentonite Control screen.

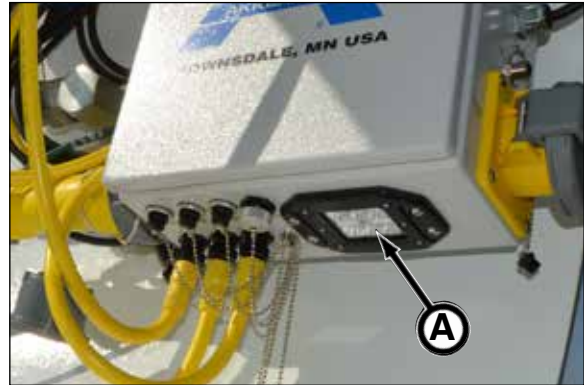

Tunnel Light (Lower Light)

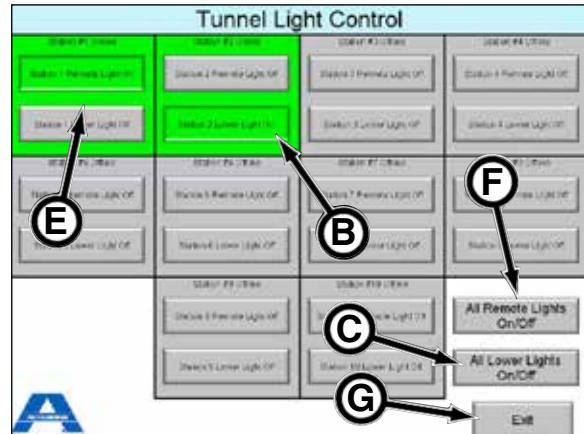

Remote Work Light

8. INSPECT & CLEAN INJECTION VALVES

• Inspect injection valve (A) operation by:

1. With power on to ABIS system and at least one remote station box connected to the monitor connections on the control station and at least one automated injection valve connected to the remote station box, navigate to the Automated Bentonite Control screen.
2. On an online station box, press Valve # On/Off button (B) and inspect the operation of the injection valve.
3. Repeat for each online injection valve. Repair or replace as needed.

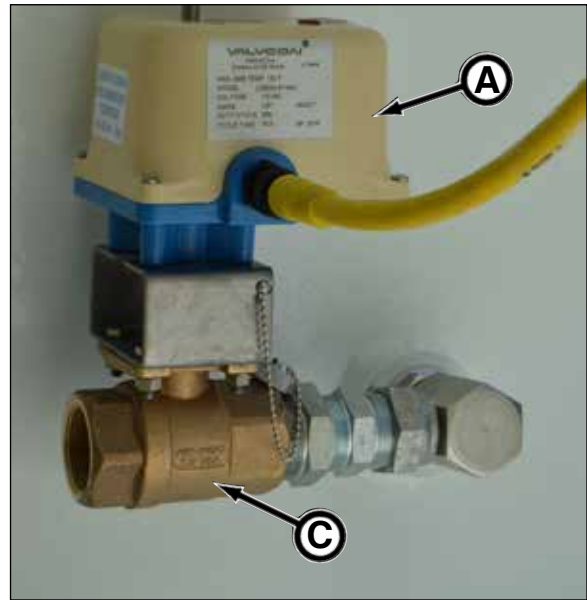

• Clean injection valve full port ball valve (C):

4. If there is any debris in ball valve, flush and cycle valve to remove debris.
5. Repeat the flush and cycle procedure until all debris is removed from valve.
6. After cleaning valve, recheck valve for proper operation. If needed, repair or replace injection valve before using ABIS system.

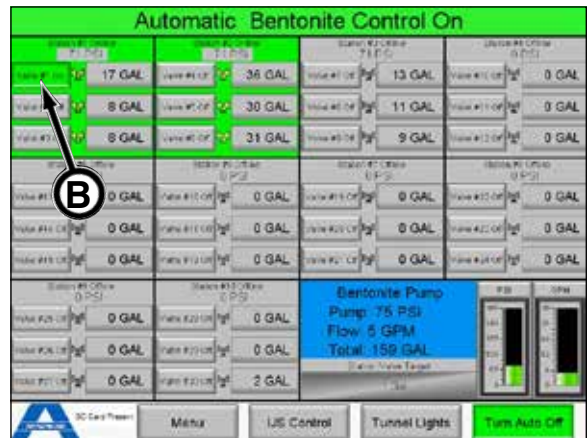

DAILY OR EVERY 10 HOURS OF OPERATION

9. CLEAN MONITOR DISPLAY SCREEN

The display screen (A) should be cleaned periodically by wiping the screen with a lint free damp cloth using a mild soap solution. Dry the surface when finished with a lint free cloth.

DO NOT clean with ammonia based products. Doing so will damage the face of the display screen.

NOTICE

To help with the longevity and to prevent damage to the display screen, avoid touching the screen with sharp objects, striking the screen with a hard object, the use of abrasives near the screen, or using excessive force when pressing the touch screen.



10. INSPECT CABLES & HOSES

1. Inspect hoses and cables for cracking, fraying, wear or damage. Repair or replace as needed.
2. Be sure cables and hoses are securely fastened to connections.

NOTICE

Keep cables clear of debris, water and fluids. Before connecting power cables, clean all connections with a non oil-based electric contact cleaner. Do not use electric contact grease since it tends to collect dust and dirt.



11. INSPECT DECALS

Inspect ALL decals to be sure they are clean and legible.

Use soft cloth, water and a mild soap to clean the decals if they are too dirty to read. **DO NOT** clean decals with solvent. Solvent will damage decals. Replace decals immediately if they are damaged, missing or hard to read.

Before applying a new decal, be sure the surface is clean and dry.



12. OPERATING ABIS SYSTEM IN FREEZING WEATHER

Freezing temperatures during the tunneling process, creates the necessity to prepare the site and equipment for the cold weather. Failure to do so will cause damage to components and supporting equipment. Refer to Cold Weather Operation in section 6, Operation.



13. BACKUP DATA LOGGING INFORMATION

Even though today's memory cards are extremely reliable, they can become unusable due to age, wear, corrupted files, electrostatic discharge and physical damage. Touching the contacts on the back of the card can also cause the card to fail.

Therefore, it is recommended to periodically backup the data logging file(s) on the SD card

1. Carefully remove the SD card from the monitor memory card slot (A).
2. Install a card reader (B) into a computer.
3. Insert the SD card (C) into the card reader.
4. A new drive will appear on the screen of your computer. This is the SD card you just installed
5. Copy the data logging file on the SD card.
6. Create a Data Logging Backup folder on your computer hard drive and paste the data logging file in this newly created folder.
7. Eject the SD card and remove the card reader from the computer.
8. Carefully reinstall the SD card into the memory card slot in the monitor.
9. Close card cover door.
10. Close and secure monitor cover.

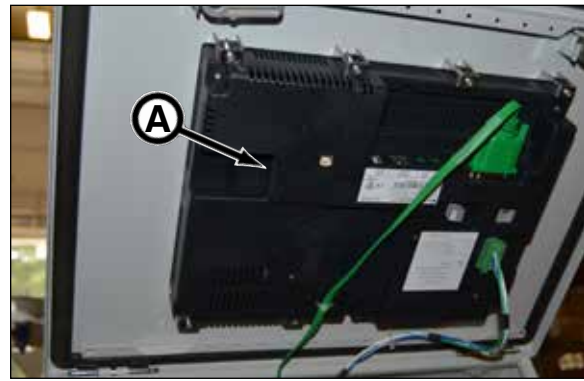

COMPLETION OF EACH DRIVE

14. INSPECT LIFT EYE

Before lifting ABIS system, check lift eye (A) for damage. A worn or damaged lift eye **MUST** be replaced before lifting the ABIS system.

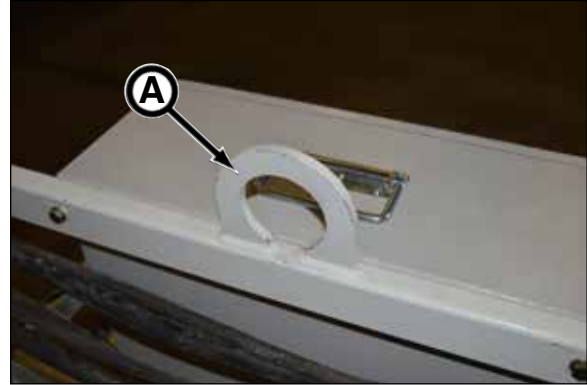

15. INSPECT CABLES & HOSES

1. Inspect hoses and cables for cracking, fraying, wear or damage. Repair or replace as needed.
2. Be sure cables and hoses are securely fastened to connections.

NOTICE

Keep cables clear of debris, water and fluids. Before connecting power cables, clean all connections with a non oil-based electric contact cleaner. Do not use electric contact grease since it tends to collect dust and dirt.



16. FLUSH & DRAIN ABIS SYSTEM

After the completion of each drive, the ABIS system must be drained and flushed.

1. Remove supply and return hoses from ABIS system. Flush and drain hoses.
2. Flush system until no sediment is visible.
3. Be sure to completely drain all lines including supply and return manifolds.
4. Use compressed air to purge any residual water left in system. Be sure circulation valve is open before doing so.
5. Cap all supply and return connections.



17. REMOVE SD CARD & BACKUP DATA LOGGING INFORMATION

1. Carefully remove the SD card from the monitor memory card slot (A).

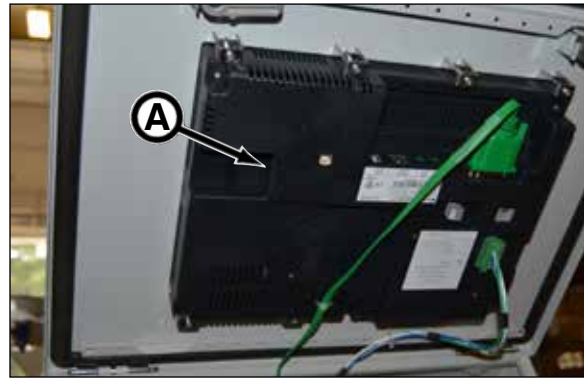

2. Close card cover door.

3. Close and secure monitor cover.



4. Install a card reader (B) into a computer.

5. Insert the SD card (C) into the card reader.

6. A new drive will appear on the screen of your computer. This is the SD card you just installed

7. Copy the data logging file on the SD card.

8. Create a Data Logging Backup folder on your computer hard drive and paste the data logging file in this newly created folder.

9. Eject the SD card and remove the card reader from the computer.

10. Carefully place the SD card in a protective case and store it in a safe location.



18. CLEAN INJECTION VALVES

- Clean injection valve full port ball valve (A):

1. If there is any debris in ball valve, flush and cycle valve to remove debris.
2. Repeat the flush and cycle procedure until all debris is removed from valve.
3. After cleaning valve, recheck valve for proper operation. If needed, repair or replace injection valve before using ABIS system.

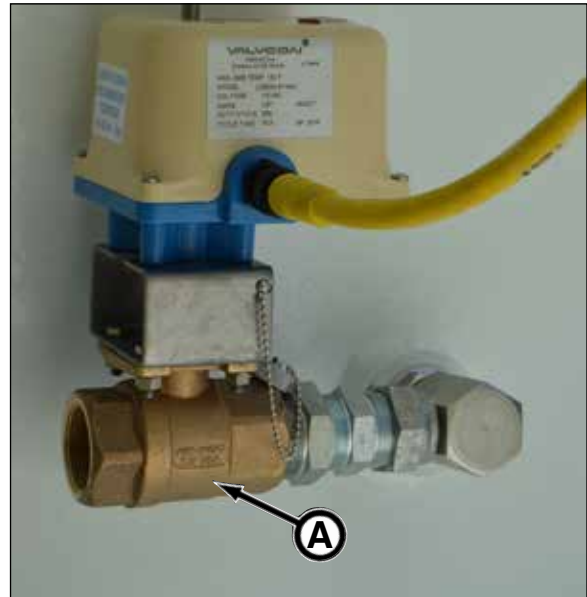

NOTES

Storage

PREPARING FOR STORAGE

1. Repair worn or damaged parts.
2. Wash all equipment thoroughly.
3. Flush and drain ABIS system to prevent damage from freezing weather.
4. Remove ABIS monitor from control station and if possible, store in a climate controlled environment.
5. Thoroughly clean automatic bentonite injection valves.
6. Remove backup battery and store in a climate controlled environment.
7. Repaint equipment where necessary.
8. Store equipment in a clean, dry, ventilated location.

REMOVING FROM STORAGE

1. Clean equipment thoroughly.
2. Check to make sure all decals are clean and readable.
3. Check condition of wires and cables. Repair or replace as necessary.
4. Replace backup battery and SD card (if removed) into ABIS monitor.
5. Check condition of all hoses and connections. Tighten, repair or replace with new as needed.
6. Review this Operation Manual.

NOTES

Troubleshooting

ABIS SYSTEM

Problem	Cause	Solution
ABIS system does not operate.	Power cable is not installed.	Plug in power cable to 120 VAC.
	Power cable to remote station box is not installed.	Install power cable from monitor to remote station box.
	Communication cable from monitor to remote station box is not connected.	Install communication cable.
Bentonite pump is operating but flow reading is 0.	Bentonite pump tank is empty.	Fill tank.
	Flow meter cable is not connected to flow meter connection on monitor.	Connect flow meter cable to Bent. Flow Meter connection on monitor.
	Flow meter failure.	Repair or replace flow meter.
Bentonite pump is properly connected to monitor but no pressure is visible.	Bentonite pump is shut down.	Start up bentonite pump.
	The Bent PSI cable connection to monitor is not installed.	Install pressure transducer cable to Bent. PSI Trans 300 on monitor.
Too much or not enough bentonite pump pressure.	Circulation (unloader) valve failure.	Inspect and replace or repair circulation valve.
The automated injection valves not operating continuously.	The valve sequence is setup to stop operation at the end of the initial sequence.	To automate sequence, be sure the ending sequence box has a "0" not "31" in the box.
	Automated injection valve failure.	Check valve operation. Replace or repair.
	Automated valve is plugged.	Inspect and clean automated valve(s).
	Control relay failure.	Replace control relay.
Too much or not enough bentonite is being pumped into tunnel valves.	The Station Valve Target volume is not properly set.	Increase or decrease the Station Valve Target volume as needed.
Tunnel or working lights are not operating.	The lights are not turned on.	Turn tunnel or working lights on.
	Selected light(s) are offline.	Selected light(s) station box must be online.
Manual valve operation not working.	Cables not properly connected.	Install cable connections.
	Selected valve is offline.	Selected valve station box must be online to operate.
There are no data logging files.	SD card is not installed.	Install SD card.
	SD card is locked (write-protected).	Unlock SD card.
The data logging files are unintentionally reset to zero.	Power is shutdown and the backup battery is not installed or battery is dead.	Install backup battery.

AUTOMATED INJECTION VALVES

Problem	Cause	Solution
Automated valve will not rotate or operate.	Valve packed with debris.	Cycle & flush to remove debris.
	Actuator has failed.	Repair or replace actuator.
Automated valve ball/seat leaking.	Valve not fully closed.	Close the valve.
	Debris trapped in valve.	Cycle & flush to remove debris.
	Seat or ball damaged.	Repair or replace as needed.

INTERMEDIATE JACKING STATIONS

Problem	Cause	Solution
IJS stations are not operating.	Station IJS disabled.	Enable the IJS station using the IJS Setup screen.
	IJS control valve connection on remote station box is not connected to the control valve connection at IJS	Connect IJS control valve cable from remote station box to IJS control valve.
Too much or not enough IJS hydraulic pressure.	Incorrect kick out pressure.	Set the proper kick out pressure in the IJS Setup screen.
	Faulty IJS pump.	Repair or replace IJS pump.
No IJS hydraulic pressure.	Cable not connected from IJS PSI TRANS 10,000 on monitor to IJS pressure transducer connection at IJS pump.	Install cable from monitor to IJS pump connections.
	Remote station control box IJS PSI cable not connected to pressure transducer at the IJS station.	
	Faulty IJS pump.	Repair or replace IJS pump.
IJS not displaying cylinder extension measurement	Cable not connected from IJS Position on remote station control box to linear transducer at IJS not connected.	Install cable from IJS Position to IJS linear transducer connections.

NOTES

ELECTRICAL SCHEMATIC - ABIS MONITOR (SN FA15350F-01)

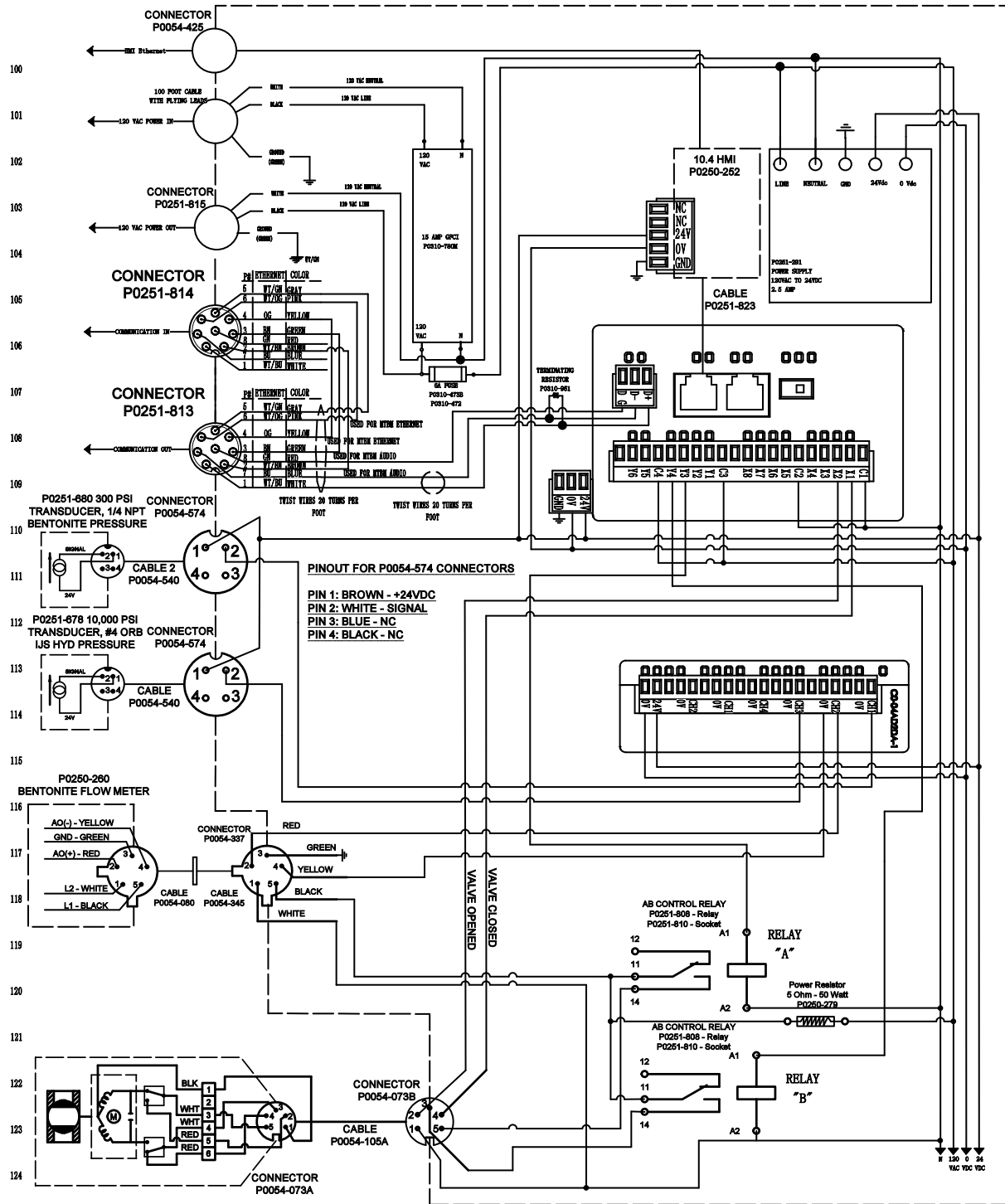

PINOUT FOR P0054-073B CONNECTORS

- PIN 1: WHITE - Neutral
- PIN 2: RED - Opened Sw
- PIN 3: GREEN - Close
- PIN 4: ORANGE - Closed Sw
- PIN 5: BLACK - Open

ELECTRICAL SCHEMATIC - ABIS MONITOR (SN FA15350F-02 & AFTER)

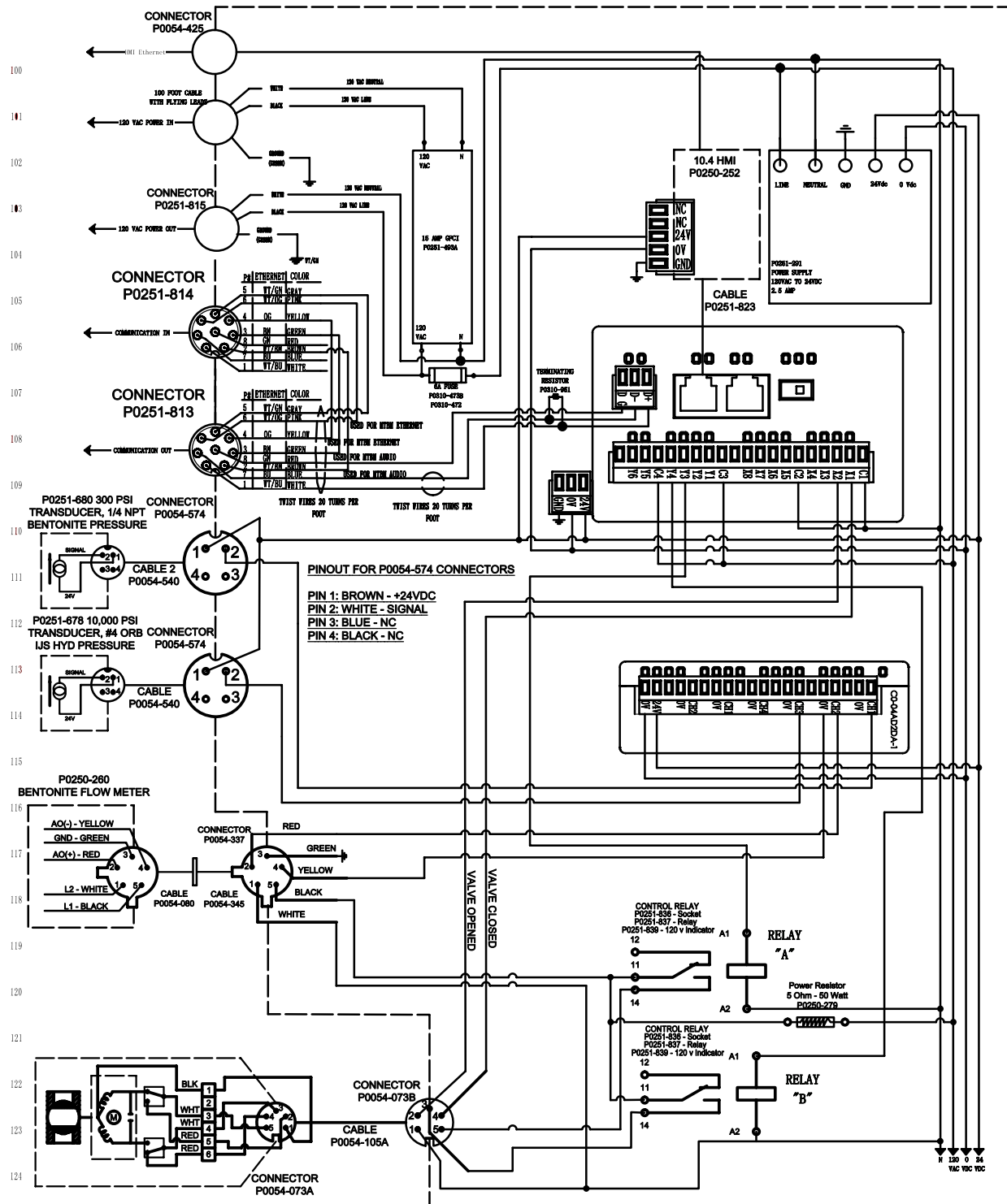

PINOUT FOR P0054-073B CONNECTORS

- PIN 1: WHITE - Neutral
- PIN 2: RED - Opened Sw
- PIN 3: GREEN - Close
- PIN 4: ORANGE - Closed Sw
- PIN 5: BLACK - Open

ELECTRICAL SCHEMATICS - ABIS STATION (PART 1 OF 2) (SN FA15350F-01)

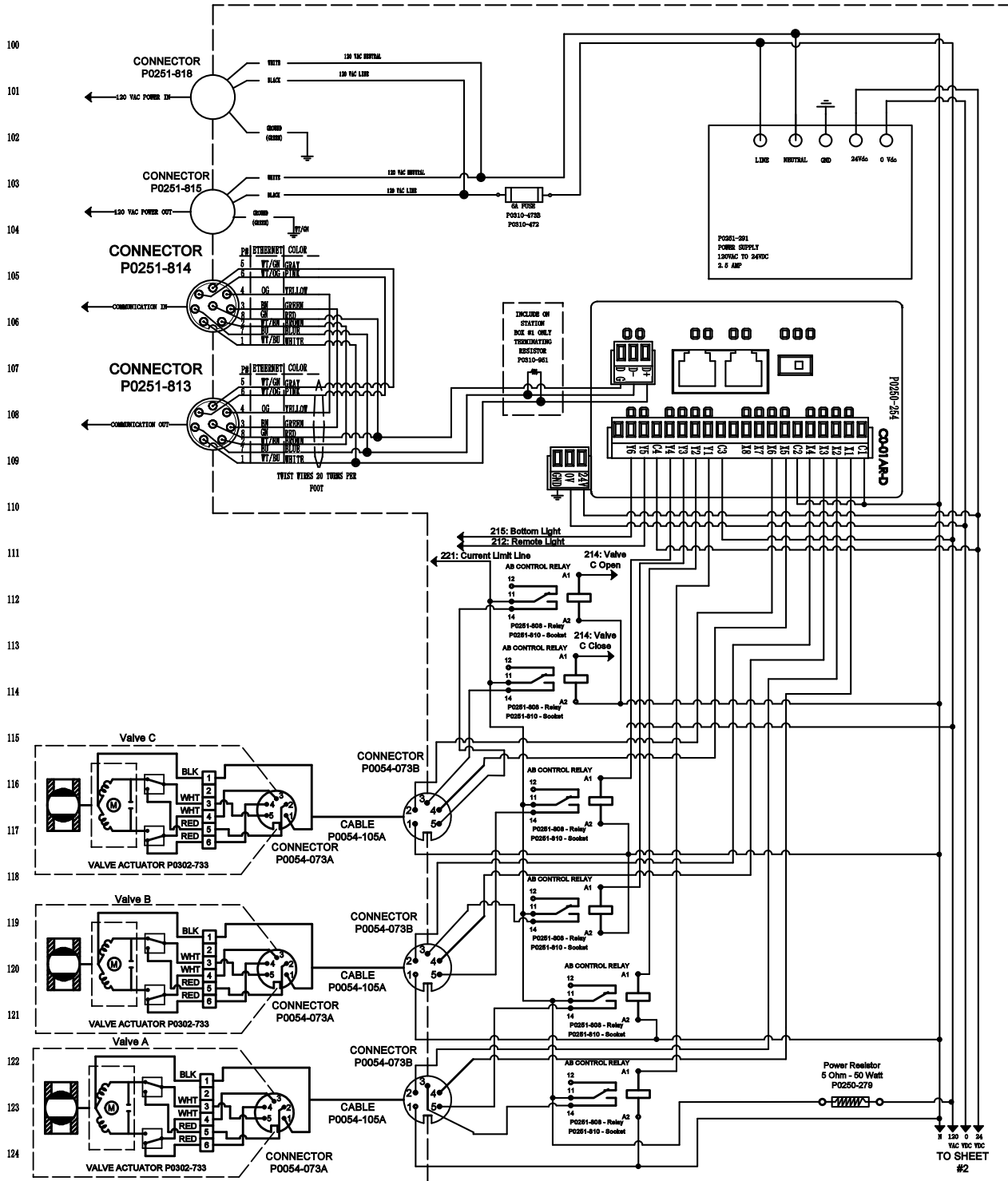

PINOUT FOR P0054-073B CONNECTORS

- PIN 1: WHITE - Neutral
- PIN 2: RED - Opened Sw
- PIN 3: GREEN - Close
- PIN 4: ORANGE - Closed Sw
- PIN 5: BLACK - Open

ELECTRICAL SCHEMATICS - ABIS STATION (PART 2 OF 2) (SN FA15350F-01)

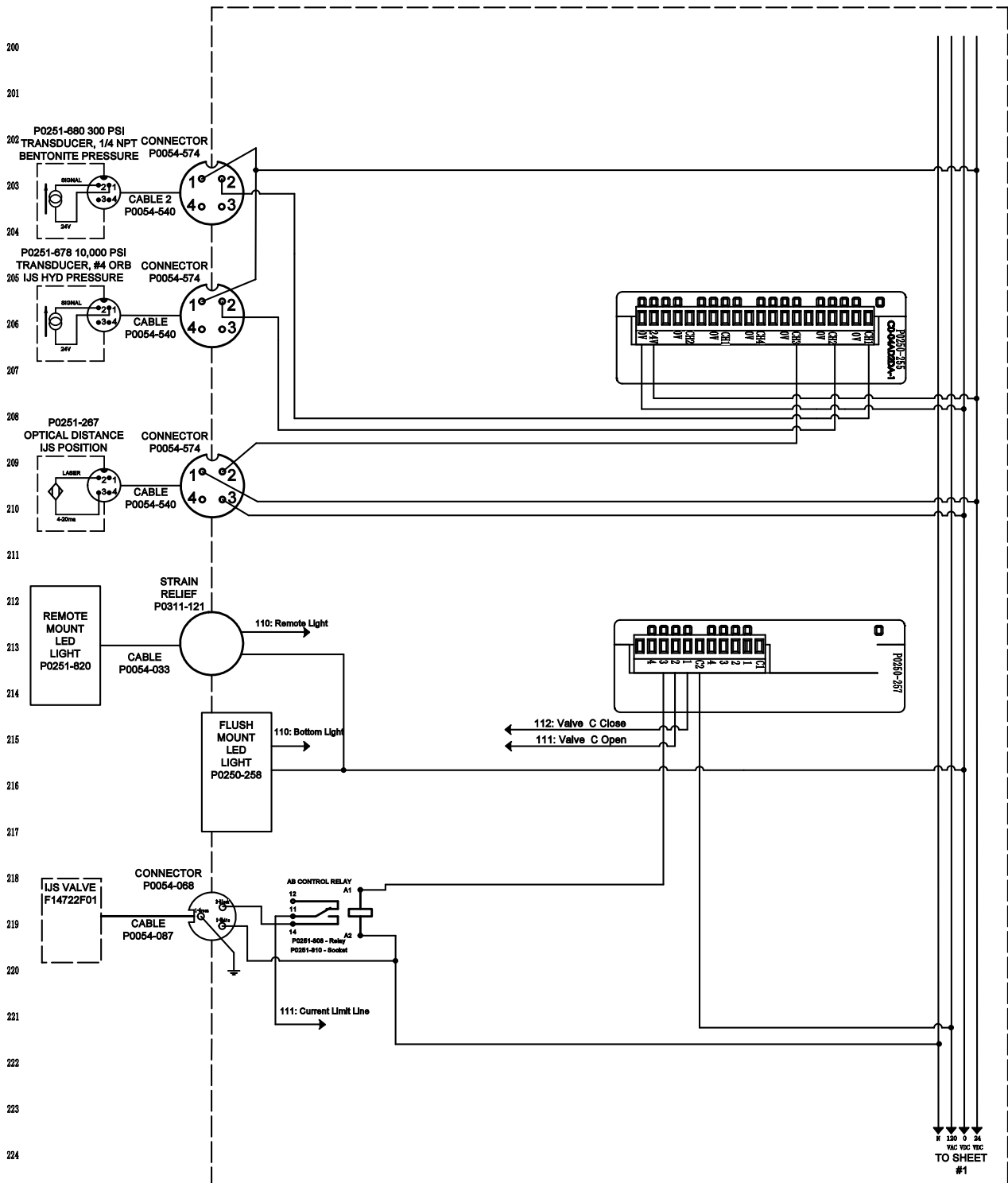

ELECTRICAL SCHEMATICS - ABIS STATION (PART 1 OF 2) (SN FA15350F-02 & AFTER)

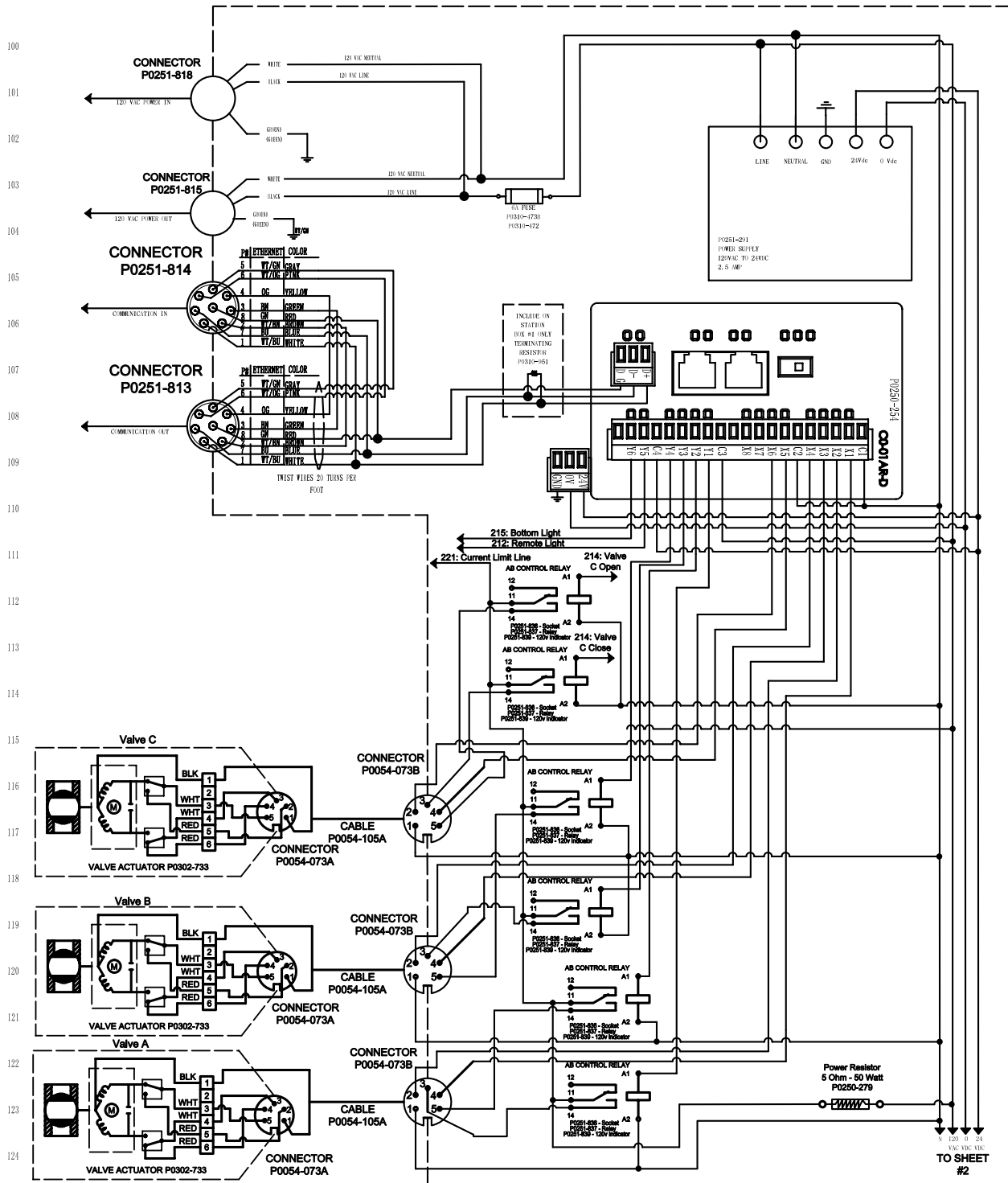

PINOUT FOR P0054-073B CONNECTORS

- PIN 1: WHITE - Neutral
- PIN 2: RED - Opened Sw
- PIN 3: GREEN - Close
- PIN 4: ORANGE - Closed Sw
- PIN 5: BLACK - Open

ELECTRICAL SCHEMATICS - ABIS STATION (PART 2 OF 2) (SN FA15350F-02 & AFTER)

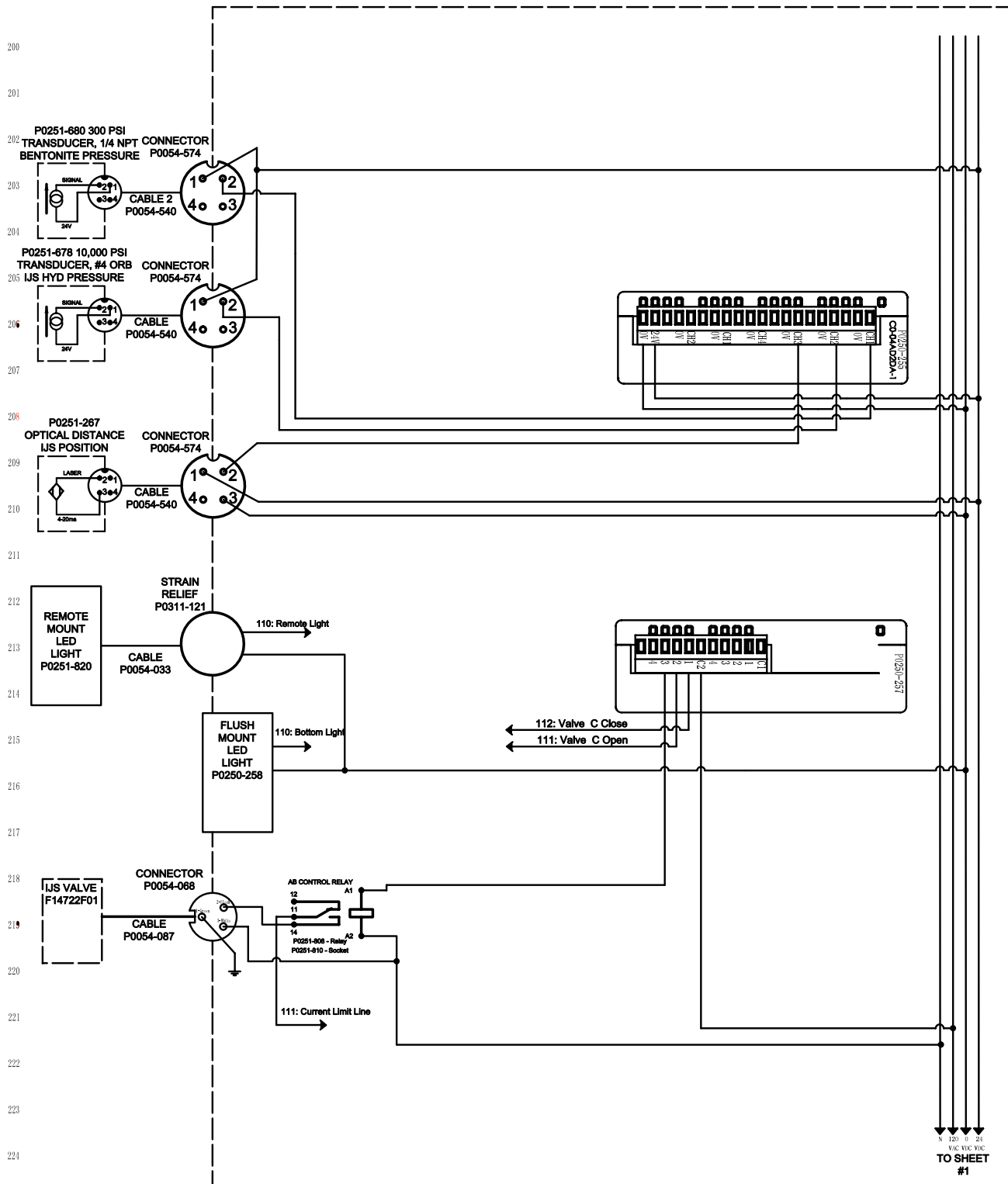

NOTES

Specifications



Control Station

Station Dimensions (L x W x H)	40 x 26 x 36 in. (1,016 x 660 x 914 mm)
Monitor Box Dimensions (L x W x H)	16 x 20 x 8 in. (406 x 508 x 203 mm)
Power In/Out	120 VAC, Single Phase
Sensor Valve Control Electrical Bulkhead	Bentonite & IJS Pressure Transducers, Bentonite Circulation & Flow Meter Valves
Communications	MODbus
Resistive Touch Screen Monitor Display	10.4 in. (264 mm)

Flow Meter

Flow Signal	4-20 mA
Pressure Transducer	0 - 300 psi
Flow Rate	0 - 30 gpm

Remote Station Control Boxes (x 10)

Dimensions (L x W x H)	12 x 12 x 6 in. (305 x 305 x 152 mm)
Power In/Out	120 VAC, Single Phase
Communications	MODbus
Sensor Valve Control Electrical Bulkhead	Bentonite & IJS Pressure Transducers, IJS Position & Control
Integrated Light	LED, 24V, 1,000 lm
Remote Work Light	6 in. (152 mm), LED 24V Light Bar, 1,000 lm with 3.2 in. (81 mm) magnet and 30 ft. (9.1 m) Cord

Automated Injection Ball Valve Assemblies (x 3 per each Remote Station Control Box)

Dimensions (L x W x H)	6 x 5 x 11 in. (152 x 127 x 279 mm)
NPT Connections	1.5 in. (38 mm)

TORQUE CHART

Use these torque values as a guideline when tightening hardware unless otherwise specified in this manual.

Lubricated Coarse UNC Threads Grade 8 Fasteners			Lubricated Fine UNF Threads Grade 8 Fasteners		
Bolt Size	Torque		Bolt Size	Torque	
	ft. lbs.	(N·m)		ft. lbs.	(N·m)
1/4 - 20	10	(14)	1/4 - 28	11	(15)
5/16 - 18	20	(27)	5/16 - 24	22	(30)
3/8 - 16	35	(47)	3/8 - 24	39	(53)
7/16 - 14	56	(76)	7/16 - 20	62	(84)
1/2 - 13	85	(115)	1/2 - 20	96	(130)
9/16 - 12	123	(167)	9/16 - 18	137	(186)
5/8 - 11	170	(231)	5/8 - 18	192	(260)
3/4 - 10	301	(408)	3/4 - 16	336	(456)
7/8 - 9	450	(610)	7/8 - 14	500	(678)
1 - 8	680	(922)	1 - 12	740	(1003)
1-1/8 - 7	960	(1302)	1-1/8 - 12	1030	(1397)
1-1/4 - 7	1360	(1844)	1-1/4 - 12	1500	(2034)
1-1/2 - 6	2360	(3200)	1-1/2 - 12	2660	(3607)

Identification Numbers

Model and serial numbers are required when ordering parts or requesting service information. Record your model and serial numbers below.

ABIS Control Station

Model Number _____

Serial Number _____



ABIS Control Station

ABIS Remote Station Control Box

Model Number _____

Serial Number _____

Model Number _____

Serial Number _____

Model Number _____

Serial Number _____

Model Number _____

Serial Number _____

Model Number _____

Serial Number _____

Model Number _____

Serial Number _____

Model Number _____

Serial Number _____

Model Number _____

Serial Number _____

Model Number _____

Serial Number _____

Model Number _____

Serial Number _____



ABIS Remote Station Control Box

NOTES

Safety Data Sheets

The Federal Occupational, Safety, and Health Administration (OSHA) Standard 29 CFR 1910.1200, require that specific safety data sheets (SDS) be available to employees before operating this equipment. This may include information on substances contained in this equipment such as fuel and gear lubricant.

Akkerman Inc. will provide, at no cost, SDS which apply to its product line. Simply contact your Akkerman Aftermarket Support representative for a copy.

To ensure a prompt response to your SDS request, include your return address (including zip or postal code) and the equipment's model numbers and serial numbers with your request.

NOTES

Warranty

Akkerman Inc. warrants that all equipment manufactured by it be free from defects due to workmanship or material under normal use and service for a period of 90 days. This warranty does not apply to normal wear items such as cutter teeth, filters, etc. Akkerman Inc. does not warrant the fitness of its equipment for a particular purpose or application.

Warranty

NOTES

Index

Symbols

120 VAC incoming power cable	6-18
120 VAC in connection	6-5, 6-7
120 VAC power cord	6-12
120 VAC supply	6-12
.Txt data file	6-21
.Txt data files	6-20

A

Abis communication cable	6-18
Abis - control station, terminology	3-1
Abis data variables	6-23
Abis monitor, electrical schematic	11-4, 11-4
Abis monitor ethernet connection	6-23
Abis software	4-1
Abis software screens . 4-2, 4-3, 4-4, 4-5, 4-6, 4-7	
Abis standard configuration	6-6
Abis station electrical schematics	11-6 - 11-9
Abis system, assembling the	6-4
Abis system backup battery	9-6, 9-15
Abis system, flush & drain	9-12
Abis system for operation, preparing the	6-12
Abis system in freezing weather	9-11
Abis system menu screen	6-11, 6-21
Abis system menu screen	6-13
Abis system message notifications	6-22
Abis system monitor screen	6-22
Abis system, operating the	6-14
Abis system, operating the IJS stations with ..	6-25
Abis system operations	6-20
Abis system setup	6-6
Abis system troubleshooting	11-1
Abis system tunnel layout with IJS, typical	6-3
Abis system tunnel layout without IJS, typical...	6-3
Accumulated volume totals	6-21
Adding new pipe and utilities	6-14
Adding new pipe & utilities	6-18
Additional pipe	6-7
Advancement alarm system	6-2
Akkerman bentonite injection system	6-2
Alarm_datecode.Txt	6-22
Alarm notification	6-2
All lower lights on/off button	4-5, 6-16, 9-8
All remote lights on/off button	4-5, 6-16, 9-8
Annually	9-4, 9-15
Assembling the abis system	6-4
Automated bentonite control screen	9-14
Automated bentonite injection valve	
cable connection	6-6
terminology	3-3
Automated injection ball valve assemblies	
specifications	12-1
Automated injection valves troubleshooting ...	11-2
Automated operation	6-11

A (continued)

Automatic bentonite control	4-3
Automatic bentonite control screen	
.....6-14, 6-15, 6-16, 6-19, 9-6, 9-8	
Auto on/off button	4-3
Auto operation	6-14
Auto operation, continuous	6-11
Auto operation, setting up valve sequence for..	6-11
Avoid pinch points	1-4

B

Backup battery	6-22
Backup battery, abis system	9-6, 9-15
Backup data logging information	9-11
Battery, abis system backup	9-6
Battery backup	9-6
Battery, CR2354	9-2, 9-4, 9-6, 9-15
Battery door	9-6
Battery, low/no	4-3, 6-22, 9-6
Bentonite control screen	4-3
Bentonite control screen	4-2, 4-6, 6-18, 6-25
Bentonite control screen	6-10, 6-11
Bentonite flow meter cable connection	6-4
Bentonite hoses	6-12
Bentonite hoses, installing	6-9
Bentonite ports	9-9, 9-14
Bentonite pressure	4-3
Bentonite pressure transducer connection 6-5, 6-6	
Bentonite psi connection	6-6
Bentonite psi trans 300 connection	6-5
Bentonite pump	6-14, 6-19
Bentonite pump flow	4-3, 6-12
Bentonite pump output	4-3
Bentonite pump pressure	4-3
Bentonite return hose	6-9
Bentonite supply hose	6-9
Bentonite unloader valve cable connection	6-4
Bulkhead connection	6-23

C

Cables & hoses inspection	9-5, 9-10, 9-12
Card reader	6-20, 9-11, 9-13
Circulation valve	9-6, 9-12
Circulation valve connection	6-4
Clear totals button	4-2, 6-13, 6-21
Clothing, wear protective	1-1
Coin-type slot	9-6, 9-15
Cold weather operation	6-17
Cold weather operation	6-19
Comm in connection	6-5, 6-7
Comm out connection	6-7
Communication cable	6-7
Completion of each drive	9-12
Completion of each drive	9-4

C (continued)

Compressed air	6-17, 9-12
Computer operation, check	9-6
Connecting abis system to micro	6-23
Contents	iii
Continuous auto operation	6-11
Controls & instruments	4-1
Controls & instruments, system menu screen ...	4-2
Control station	6-2
Control station specifications	12-1
Corrupted files	9-11
Cr2354 battery	9-6, 9-15

D

Daily or every 10 hours of operation	9-3, 9-10
Daily shutdown	6-19
Daily shutdown procedure	6-14
Data log_bentonite_pressures_datecode.Txt..	6-20
Data, logged	6-13
Data logging	4-2, 6-20
Data logging backup folder	9-11, 9-13
Data logging file	9-11, 9-13
Data logging information	9-7
Data logging information, backup	9-11
Data log_IJS_1-5_info_datecode.Txt	6-20
Data log_IJS_6-10_info_datecode.Txt	6-20
Data log_station1-5_totals_datecode.Txt	6-20
Data log_station6-10_totals_datecode.Txt	6-20
Data variables	6-23
Decals	2-1
Decals inspection	9-10
Delimited file type	6-21
Detecting battery	6-22
Detecting sd1 for logging data	6-22
Display screen	9-10
Distributed control system	6-2
Drain hoses	6-17

E

Electrical schematic - abis monitor	11-4, 11-5
Electrical schematics - abis station	11-6 - 11-9
Electrostatic discharge	9-11
ENT	6-11, 6-12, 6-24
Ethernet cable	6-23

F

Finger oils	9-7
Fire prevention	1-4
Flow meter	4-3
Flow meter specifications	12-1
Freezing temperatures	6-17, 9-11
Freezing weather	6-19
Freezing weather, abis system in	9-11

G

Gal button	6-12
Gold contacts	9-7
Guidelines, operating	6-1

G (continued)

Guidelines, transporting	7-1
--------------------------------	-----

H

HMI ethernet connection	6-23
Hydraulic pressure	4-7
Hydraulic pressure meter	6-25

I

Identification numbers	13-1
Ignore button	6-22
IJS control button	4-3
IJS control screen	6-25
IJS control screen	4-6
IJS control valve connection	6-7
IJS control valve connection	6-7
IJS cylinder linear transducer	6-13
IJS cylinder pressure	6-13
IJS cylinder pressure transducer	6-13
IJS hydraulic pressure	4-7, 6-24
IJS linear transducer cable connection	6-8
IJS position connection	6-8
IJS pressure transducer cable connection .	6-5, 6-8
IJS psi connection	6-8
IJS psi trans 10,000 cable connection	6-5, 6-8
IJS psi trans 10,000 connection	6-5, 6-8
IJS pump hydraulic pressure	4-6, 6-25
IJS pump psi gauge	4-6, 6-25
IJS setup screen	4-2, 4-7, 6-24, 9-6
IJS stations, setting up the	6-24
IJS stations with abis system, operating the ...	6-25
Import wizard window, text	6-21
Injection valve full port ball valve	9-9, 9-14
Injection valves	9-9, 9-14
Inspection, pre-start	5-1
Installing additional remote station control boxes in pipeline	6-7
Installing bentonite hoses	6-9
Instruments & controls	4-1
Intermediate jacking stations troubleshooting ..	11-2
Introduction	i

J

Job site clean	1-5
----------------------	-----

K

Kick out pressure	6-25
Kick out pressure button	4-7, 6-24

L

Laser light exposure	1-2
Lift eye inspection	9-5, 9-12
Light exposure, laser	1-2
Light operation	9-8
Lights, tunnel	6-13
Linear meter	4-6, 6-25
Lint free damp cloth	9-10

L (continued)

Locked card	9-7
Lockout power	1-2, 9-1
Log folder	6-20, 6-22
Logged data	6-13
Low/no battery	4-3, 6-22, 9-6
Lower light (tunnel light) button	6-16
Lubricants	8-1
Lubrication system	6-2

M

Main screen	4-3
Maintenance charts	9-2
Maintenance, periodic	9-1
Maintenance procedures - annually	9-15
Maintenance procedures - completion of each drive	9-12
daily or every 10 hours of operation	9-10
prior to each job launch	9-5
Manual mode, operating the abis system in ...	6-15
Maximum hydraulic pressure values	6-24
Maximum values	6-11
Memory card slot	9-11, 9-13
Menu button	4-3
Microsoft excel	6-21
Microsoft® excel®	6-20
Minimum hydraulic pressure values	6-24
Minimum values	6-11
Monitor display screen	9-10
Monitor memory card slot	6-20
Monitor to control station	6-4
Monitor to remote station control box	6-5
Moving parts, keep away from	1-3
MTBM ethernet IN connection	6-23

N

No battery	4-3, 6-22, 9-6
No SD card	4-3, 6-22
No smoking in tunnel	1-5
Notification window	6-22
Numeric entry window	6-11, 6-24
Numeric keypad	6-24

O

Offline station boxes	6-13
Online station box	9-8, 9-9
Online station boxes	6-13
Operating guidelines	6-1
Operating the abis system	6-14
Operating the abis system in manual mode ...	6-15
Operating the IJS stations with abis system ...	6-25
Operation	6-1
Operational decals	2-1
Operation, cold weather	6-17
Out of tunnel connection	6-9
Overview	6-2

P

Periodic maintenance	9-1
Pinch points, avoid	9-1
Pinch points, avoid	1-4
Pipe check valve	6-6, 6-9
PLC unit	9-6
Practice safe maintenance	1-3
Preparing for storage	10-1
Preparing the abis system for operation	6-12
Pressure meter	4-6
Pressure transducer	4-3, 9-14
Pre-start inspection	5-1
Prior to each job launch	9-5
Prior to each job launch	9-2
Program, spreadsheet	6-20
Pump bentonite pressure	4-3

R

Read operator's manual	1-1
Recycle waste	1-5
Remote light button	6-16
Remote station control box	6-25
Remote station control box 120 VAC out connection	6-7
Remote station control boxes specifications ...	12-1
Remote station control box, terminology	3-2
Remote station control box to automated bentonite injection valves	6-6
Remote station control box to IJS station	6-8
Remote work light	9-8
Remote work lights	4-5, 6-16
Removing from storage	10-1
Report generator program	6-23
Retaining clip	9-6
Return to main screen	4-2
Rv anti-freeze solution	6-17

S

Safety	1-1
Safety data sheets	14-1
Safety decals	2-1
Safety information, be alert for	1-1
Screen, system menu	4-2
SD1 is write protected	6-22
SD card	6-20, 6-22, 9-11, 9-13
SD card & backup data logging information ...	9-13
SD card installation	9-7
SD card present	4-3, 6-22, 9-7
SD card requirement	9-7
SDHC card	9-7
Sequence # 1 box	6-11
Sequence boxes	6-11
Sequence order	6-11
Sequence setup	4-4
Serial numbers	13-1
Setting up the IJS stations	6-24
Setting up the valve sequence	6-10

S (continued)

Setting up valve sequence for auto operation ..	6-11
Setup the IJS station control	6-13
Setup, valve sequence	6-10
Shutdown, daily	6-19
Slippery when wet	1-4
Software, abis	4-1
Specifications	12-1
Specifications, control station	12-1
Specifications, flow meter	12-1
Specifications, remote station control boxes	12-1
Spreadsheet program	6-20
Standard configuration, abis	6-6
Station box	4-3
Station # box	6-24
Station box 120 VAC out connection	6-5, 6-6
Station box comm connection	6-5, 6-6
Station box tunnel lights	4-5
Station IJS button	4-6
Station # lower light button	9-8
Station valve target	6-14
Station valve target bentonite volume	6-12
Storage	10-1
Storage, preparing for	10-1
Storage, removing from	10-1
Structure inspection	9-5
Suspended loads, beware of	1-3
System menu screen	4-2
System message notifications	6-22

T

Terminology	3-1
Terminology,	
abis control station	3-1
automated bentonite injection valve	3-3
remote station control box	3-2
Test shaft & tunnel ventilation	1-2
Text import wizard	6-21
Text import wizard window	6-21
Torque chart	12-2
Transporting	7-1
Transporting guidelines	7-1
Troubleshooting	11-1
Troubleshooting,	
abis system	11-1
automated injection valves	11-2
intermediate jacking stations	11-2
Tunnel light	9-8
Tunnel light control screen	4-5, 6-16
Tunnel lights	6-13, 9-8
Tunnel lights button	4-3
Tunnel lights, controlling	6-16
Tunnel ventilation, test shaft &	1-2
Turn auto on/off button	6-14, 6-15, 6-19
Typical abis system tunnel layout	
with IJS	6-3
without IJS	6-3

U

Unauthorized welding	1-4, 9-1
----------------------------	----------

V

Valve a connection	6-6, 6-10
Valve b connection	6-6, 6-10
Valve c connection	6-6, 6-10
Valve # on/off button	9-9, 9-14
Valve sequence	6-10, 6-14
Valve sequence, setting up the	6-10
Valve sequence setup	6-10, 6-12
Valve sequence setup button	6-11
Valve sequence setup screen... ..	4-2, 6-10, 6-11, 9-6
Valve target, station	4-3
Volume dispensed	4-3

W

Warranty	15-1
Wear protective clothing	1-1
Welding	9-1
Welding on structure	9-1
Welding, unauthorized	1-4
Working lights	9-8
Write protected	9-7