



1685 0-20 GPM Water Cooling Tank FA10178F

Operation & Maintenance

Instruction Part No. 050160A

The 1685 (Gallon) 0-20 GPM Water Cooling Tank provides cooling and jetting supply for the Microtunneling Boring Machine (MTBM). This tank features auto fill capability and the ability to adjust the GPM output at the tank control panel whether the pump is stopped or running.

This FA10178F Water Cooling Tank instruction includes:

- | | |
|--------------------------------------|--------------------------------------|
| I. Terminology (page 1) | VII. Troubleshooting (page 16) |
| II. Setup and Operation (page 2) | VIII. Specifications (page 17) |
| III. Cold Weather Operation (page 8) | IX. Electrical Schematics (page 18) |
| IV. Transporting (page 9) | X. Warranty (page 20) |
| V. Maintenance (page 10) | XI. Identification Numbers (page 20) |
| VI. Storage (page 15) | |

I. Terminology

Note: On early models, the control panel is mounted at the pump assembly end of the water cooling tank.

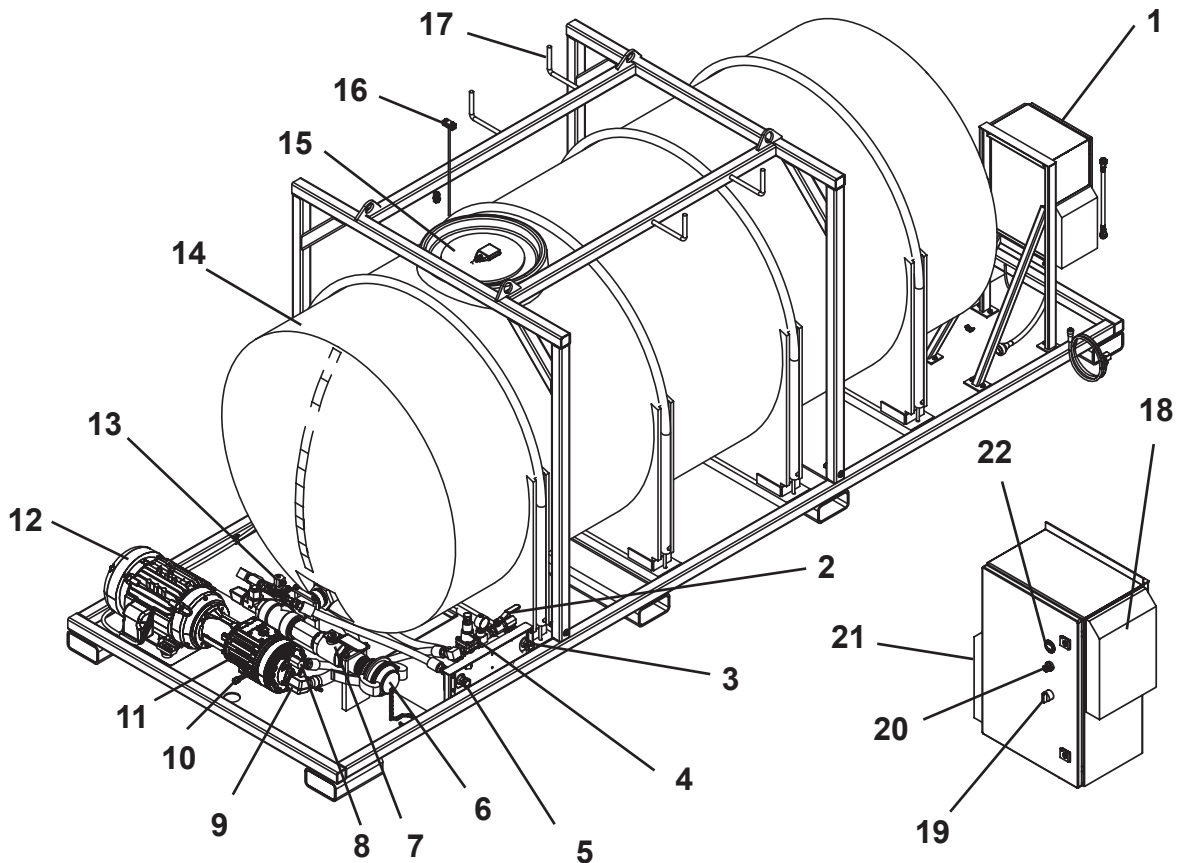

- | | |
|--|---|
| 1. Control Panel | 12. Cooling Pump Motor |
| 2. Water Discharge Ball Valve | 13. Water Fill Valve 100 psi |
| 3. Water Discharge Outlet (to tunnel) | 14. Water Tank 1,685 gal. (6,378 L) |
| 4. Pressure Relief Valve (PRV) | 15. Tank Lid |
| 5. Water Inlet | 16. Water Float Switch (inside tank) |
| 6. High Pressure Jetting Supply Outlet | 17. Power Cable Hangers |
| 7. High Pressure Jetting Supply Ball Valve | 18. Panel Air Exhaust |
| 8. Pump Outlet | 19. Water Fill Auto/On/Off Selector Control |
| 9. Pump Inlet | 20. Cooling Pump Speed (GPM) |
| 10. Pump Oil Drain | 21. Panel Air Intake |
| 11. Cooling Pump | 22. GPM Output Flow Display |

II. Setup and Operation

⚠ DANGER Follow all OSHA safety protocols and all safety instructions in your Microtunneling System Operator's Manual. Failure to do so WILL cause serious injury or death.

1. Place water cooling tank on the job site a safe distance from the launch shaft but close enough to the control container. The power and control cable is 100 ft. (30 m).



⚠ DANGER Hazardous Voltage! Disconnect and lockout/tagout power from source before connecting cooling tank to control container. Failure to do so WILL cause serious injury or death.



2. With power shut down and in lockout/tagout, connect cooling pump power cable (A) to control container cooling tank power cable connection (B) on bulkhead.

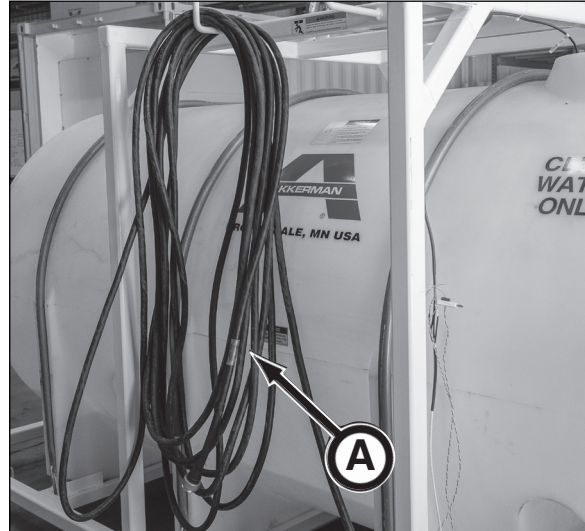

IMPORTANT: BEFORE connecting or disconnecting cooling pump power cable, be sure the 480V main disconnect breaker in the control container is OFF. Cooling power bulkhead connector will have power ANYTIME the 480V main disconnect is ON and power cable is connected.

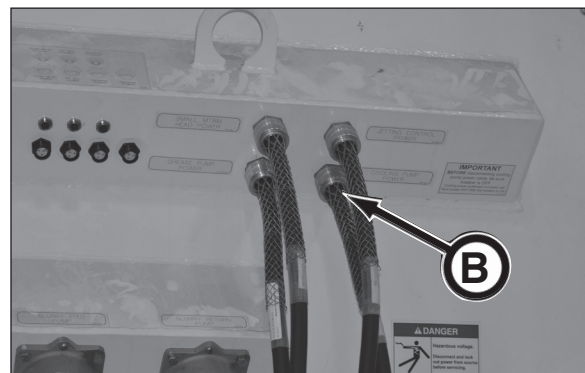

(continued on next page)

3. Connect 5 pin mini control cable from water tank cooling VFD control connection (A) to Cooling VFD Control connection (B) on control container bulkhead.

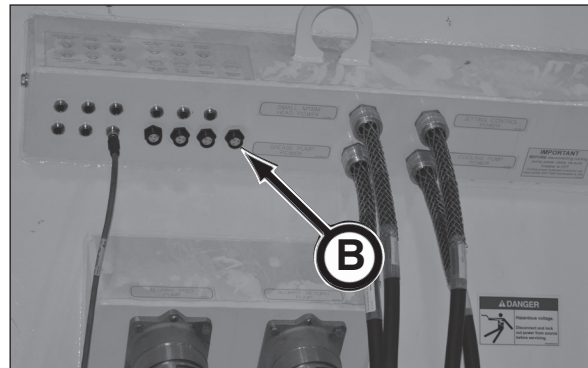
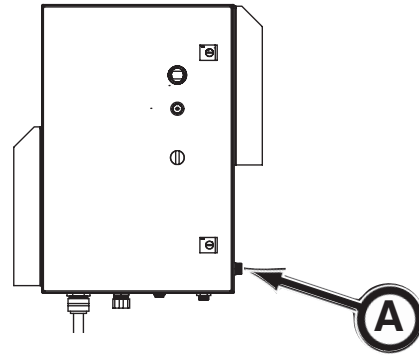

4. Hook up water supply (C) to water inlet port (D) on water tank. Maximum supply pressure is 100 psi.

IMPORTANT: Water source MUST provide clean water. Failure to do so will damage pump and MTBM components.

- Only clear water is recommended, no pond or river water.
- Pre-Filter to 50-100 mesh is recommended.

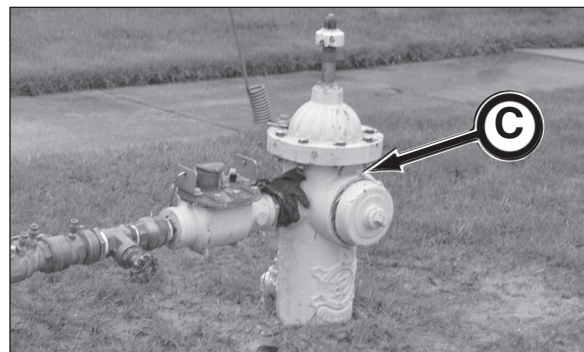

5. Hook up tunnel supply hose to cooling pump discharge connection (E).

NOTICE

At this point do not connect tunnel supply hose to the MTBM tunnel cooling line until the pressure relief valve is set properly (see step 15).

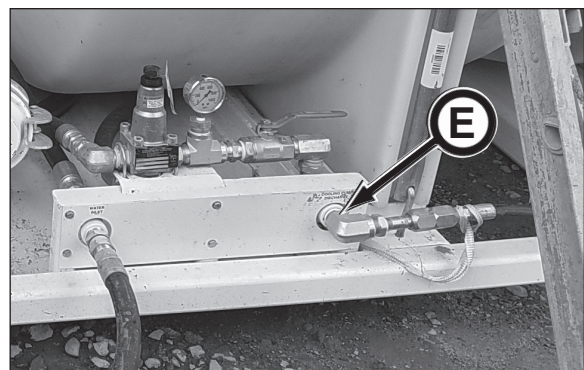

(continued on next page)

⚠ DANGER Hazardous voltage. Disconnect and lock out/tag out power from source before servicing.



6. Lock out/tag out power to the control container remote hydraulic power pack and the power container (if used).

7. Push in all E-Stop buttons (control container console, remote hydraulic power pack bulkhead, power container and pit box) to prevent accidental powering of equipment.

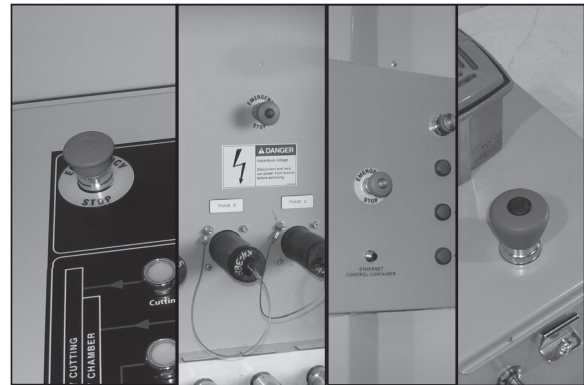

8. **BEFORE** powering up, let all job site personnel know that you are going to power up the equipment. **DO NOT POWER UP EQUIPMENT UNTIL ALL UNAUTHORIZED PERSONNEL ARE CLEAR OF THE JOB SITE.**



9. With **verification** for start up approval from all microtunneling system equipment operators and workers, start up the generator or other power source.

10. In the control container, flip the Main Disconnect to the ON position. This will provide power to the control container.



(continued on next page)

1685 0-20 GPM Water Cooling Tank Instructions - Setup and Operation

- Flip cooling pump disconnect (A) in control container to the ON position.

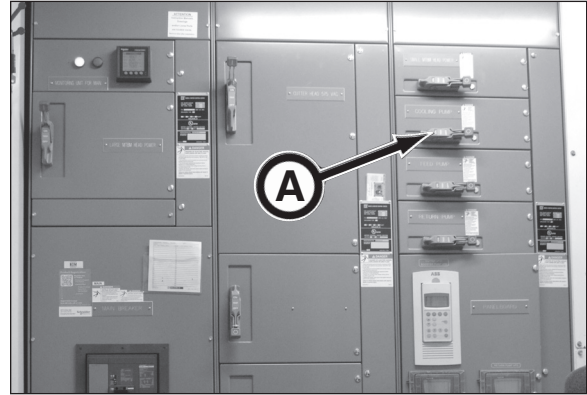

- Turn on water supply.
- Fill the water tank with clean water by moving the control switch (B) to the Auto position.

AUTO: automatically fills the tank as needed with a float switch in the tank.
 ON: manually fills tank to desired level until the switch is turned off.
 OFF: No filling of tank.

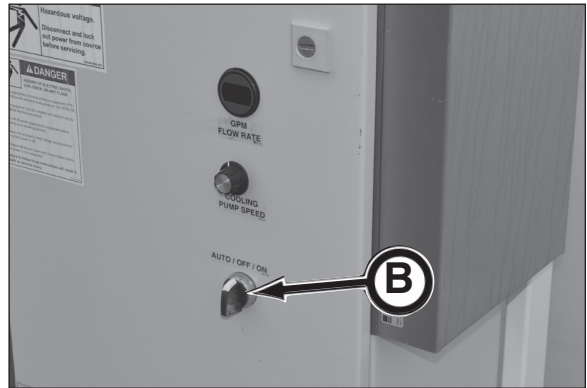

- On the control screen, click the Cooling Pump Start button (C).

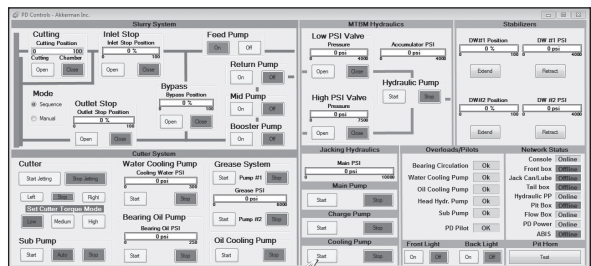

(continued on next page)

15. Adjust the PRV (pressure relief valve) (A) as follows:

a. Determine the working tunnel pressure setting (typically 250 psi) by reviewing the pressure ratings of your components; motor jackets, pump, oil cooler and cooling hoses/lines.

NOTICE

The maximum pump pressure is 1,000 psi. So if components are rated at 1,000 psi or more, set the relief to 950 psi to protect the pump.

b. Close ball valve (B).

c. Check pressure reading on pressure gauge (C) for the current pressure setting. If needed, loosen jam nut (D) on PRV valve and turn adjustment screw (E) CCW to decrease pressure or CW to increase pressure to the desired tunnel working pressure.

d. Once pressure is correct, tighten jam nut (D).

e. Fully open ball valve (B).

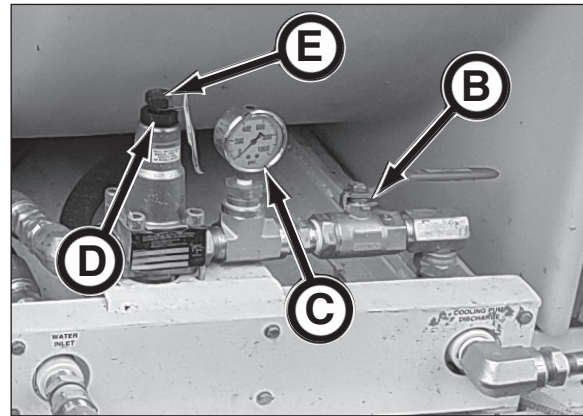
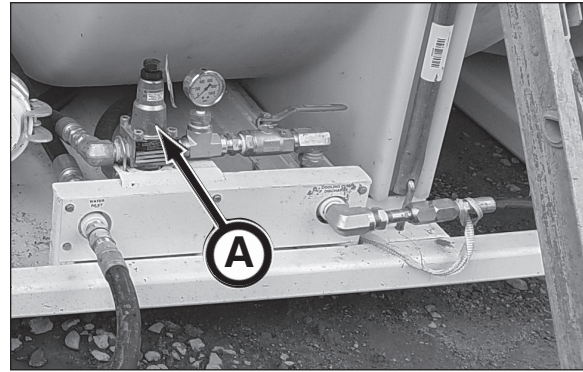

16. Turn off the cooling water by clicking the Cooling Pump Stop button (F) on the control screen.

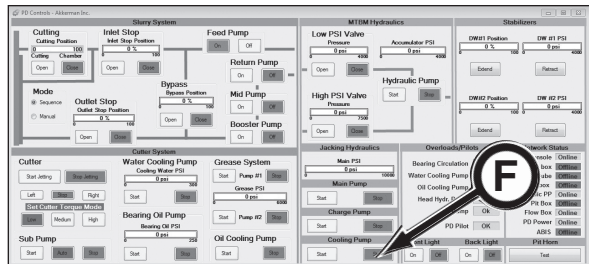

17. Connect the tunnel supply hose installed in step 5 to the MTBM tunnel cooling line.

18. Set the flow rate with the Cooling Pump Speed control (G). The flow rate will display on the GPM Output Flow display (H).

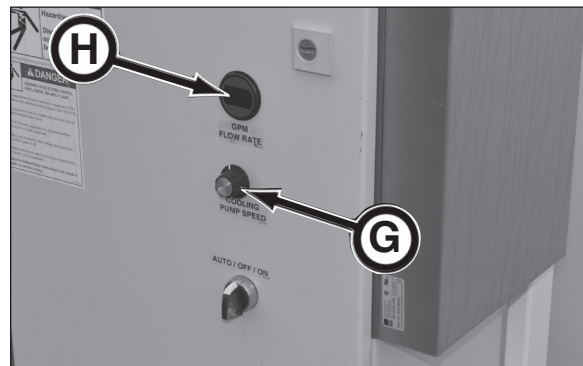

• **Center Drive MTBMs:**

- SL30 - SL52.5: 3 gpm @ 250 psi
- SL58 - SL74: 6 gpm @ 250 psi

• **Periphery Drive MTBMs:**

Follow the cooling water temperature & supply table as shown to the right: Adjust accordingly based on component temperatures.

NOTICE

The flow rate can be changed with the pump stopped or running.

(continued on next page)

SL60P	
Temp	GPM
40° F	6.9
45° F	7.9
50° F	8.8
55° F	9.9
60° F	10.9
65° F	11.8
70° F	13.1
75° F	14.4
80° F	15.7
85° F	16.9
90° F	18.2

SL74P, SL82P, SL86P	
Temp	GPM
40° F	10.6
45° F	12.1
50° F	13.6
55° F	15.2
60° F	16.7
65° F	18.2
70° F	20.2
75° F	22.1
80° F	24.1
85° F	26.0
90° F	28.0

Cooling Water Temperature & Supply Tables

19. Connect supply hose from high pressure jetting suction (A) connection to the water inlet connection (B) on the high pressure jetting pump.
20. The 1685 0-20 GPM Water Cooling Tank is ready for operation.

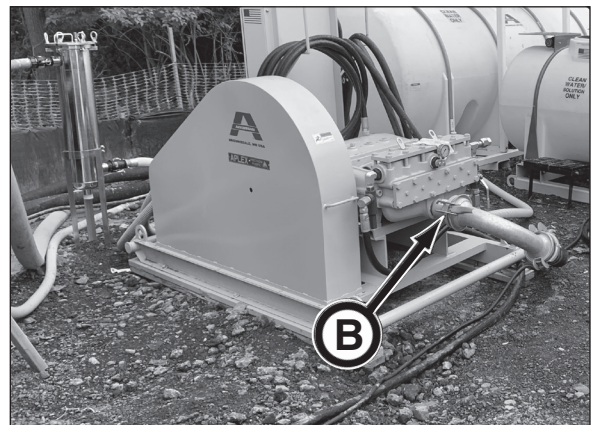
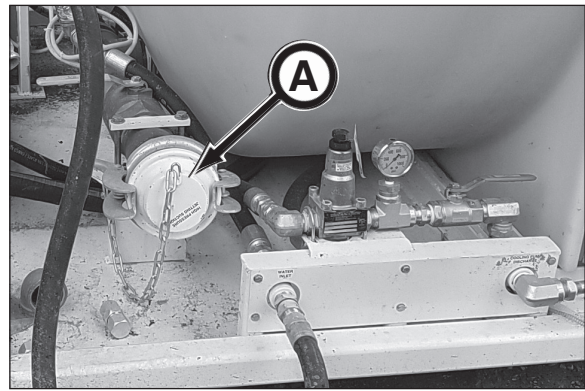

III. Cold Weather Operation

Freezing temperatures during the tunneling process, creates the necessity to prepare the site and equipment for the cold weather. Failure to do so will cause damage to components and supporting equipment.

There are various methods of keeping equipment from freezing:

- Tent working areas with a heating system when possible.
- When working with water (including bentonite), it needs to be constantly circulated to prevent freezing. Otherwise the equipment must be drained and/or treated with a RV anti-freeze solution to prevent freezing.
- If slurry pumps, bentonite pump and/or water cooling pumps will be shut off for a considerable length of time and the temperature is at or below freezing, the fluids must be drained or treated with RV anti-freeze. Refer to pump manufacturer for more information.
- Water tanks must be drained or treated with RV anti-freeze.
- Drain hoses to prevent freezing and keep low areas properly drained to prevent freezing damage.
- Motors with water jackets must be flushed including water lines and add RV anti-freeze.
- For diesel engines, use a diesel conditioner as well as a non-gelling winter fuel.
- For all equipment, use proper lubricant based on ambient temperature to prevent damage.
- Use compressed air to purge a system of water. Be sure the discharge valve is open before doing so.
- Install heaters for hydraulic systems.
- Maintain a continuous slurry bypass can prevent overnight freezing.
- A spoil (muck) dump needs to be located carefully since the wet loose material will freeze forming a pointed pile instead of a mound.



If systems were shut down for freezing weather, be sure to start systems slowly and let them run for at least five minutes to allow for warm up and in the case of a pump, to displace any surface ice that may have accumulated in the fluid before going back to full operation mode.

Remember it is also critical to keep the work site safe and employees comfortable during the freezing weather. Good training, supervision, proper clothing and limiting personal exposure to the weather is essential for keeping personnel and equipment safe on the job site.

IV. Transporting

⚠ WARNING Suspended load may fall and cause severe personal injury or death.

Do not enter area under or around a load.



Transporting Guidelines

1. Know the local, state, and federal transportation regulations.
2. Obtain required permits for transporting.
3. Remove any obstacles from the trailer floor.
4. Clean debris from equipment.
5. Load and unload on level ground.
6. Water cooling tank must be transported with an empty tank.
7. If lifting equipment with a hoist or other lifting device, the equipment lifting eyes and sling must be inspected for damage before lifting. If damaged, replace.
8. Securely fasten equipment to trailer floor.
9. Secure all loose items in control container.
10. Observe the lifting instructions below:

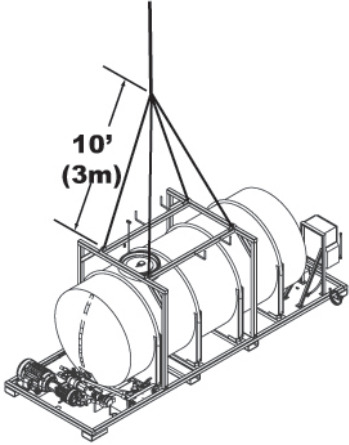
	<h1>NOTICE</h1>
	<h3>TANK FRAME LIFTING INSTRUCTIONS</h3> <ul style="list-style-type: none">- Tank frame MUST BE PICKED UP EMPTY.- Tank frame weight, empty is 3,500 lbs (1,588 kg).- Lifting with a crane requires a four part sling with legs a minimum of 10 ft. long.- Tank frame MUST lift freely. If tank is stuck to the ground, it MUST be broken loose prior to lifting.- Tank frame lifting eyes MUST be inspected prior to each lift. Any damage MUST be repaired prior to lifting. <p>1252-014</p>

V. Maintenance

NOTICE Use the item number in the chart to refer to the detailed maintenance procedures starting on the next few pages.

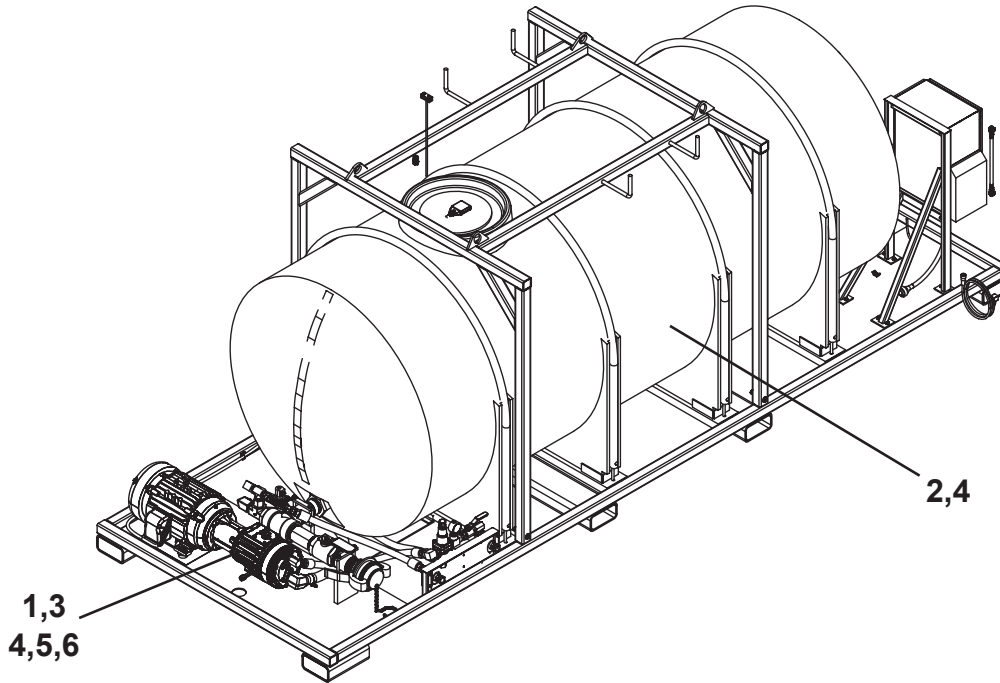

PRIOR TO EACH DRIVE LAUNCH

ITEM	COMPONENT	SERVICE	REQUIREMENT	MATERIAL
1.	Water Cool. Pump	Check Oil Level	Add oil if necessary.	10W30 Motor Oil
2.	Tank	Fill	Fill with fresh, clean water.	

DAILY OR EVERY 10 HOURS OF OPERATION

ITEM	COMPONENT	SERVICE	REQUIREMENT	MATERIAL
3.	Water Cool. Pump	Check Oil Level	Add oil if necessary.	10W30 Motor Oil
4.	Water Cool. Pump	Flush & Drain	In freezing weather.	

AFTER FIRST 100 HOURS, THEN EVERY 1000 HOURS THEREAFTER

ITEM	COMPONENT	SERVICE	REQUIREMENT	MATERIAL
*5.	Water Cool. Pump	Drain & Fill	Pump Oil Capacity - 1.1 US qt.	10W30 Motor Oil

* Drain and fill earlier with any signs of contamination.

YEARLY OR EVERY 1000 HOURS OF OPERATION

ITEM	COMPONENT	SERVICE	REQUIREMENT	MATERIAL
6.	Water Cool. Pump	Drain & Fill	Pump Oil Capacity - 1.1 US qt.	10W30 Motor Oil

PRIOR TO EACH DRIVE LAUNCH

1. CHECK WATER COOLING PUMP OIL LEVEL

Check water cooling pump (A) oil level and the condition of the oil.

The drive motor cooling pump is filled with 10W-30 motor oil.

Use a high quality 10W-30 motor oil when adding or changing lubricant.



1. Clean area around check/fill cap (B).
2. Remove check/fill cap.
3. If additional oil is needed, add a high quality SAE 10W-30 motor oil. The oil level should be 1/4 in. (6 mm) from top of the fill port.

Oil capacity is approximately 1.1 US quarts (1.05 L).

4. If oil shows signs of contamination, drain oil and refill with clean oil.
5. Replace check/fill cap.

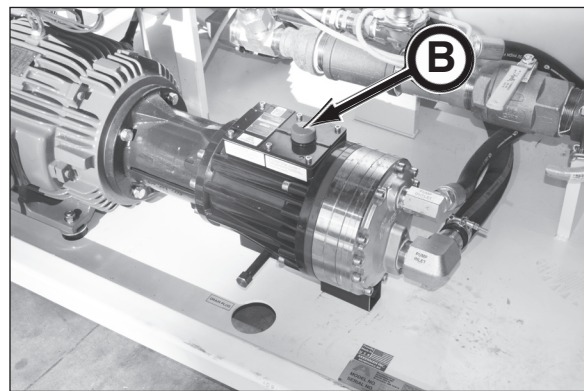

2. FILL WATER TANK

Fill water tank with fresh, clean water. Refer to page 5, step 12 for filling procedure.

The tank capacity is 1,685 gal (6,378 L).



(continued on next page)

DAILY OR EVERY 10 HOURS OF OPERATION

3. CHECK WATER COOLING PUMP OIL LEVEL

Check water cooling pump (A) oil level and the condition of the oil.

The drive motor cooling pump is filled with 10W-30 motor oil.

Use a high quality 10W-30 motor oil when adding or changing lubricant.

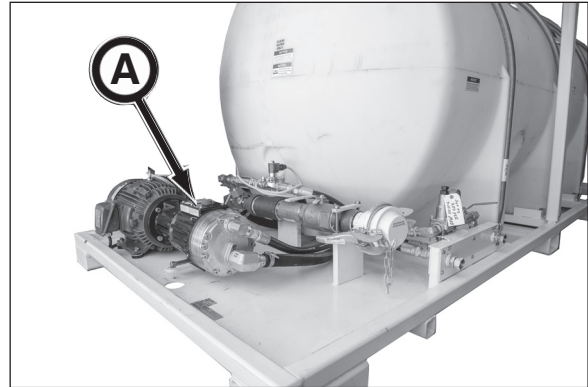

1. Clean area around check/fill cap (B).
2. Remove check/fill cap.
3. If additional oil is needed, add a high quality SAE 10W-30 motor oil. The oil level should be 1/4 in. (6 mm) from top of the fill port.

Oil capacity is approximately 1.1 US quarts (1.05 L).

4. If oil shows signs of contamination, drain oil and refill with clean oil.
5. Replace check/fill cap.

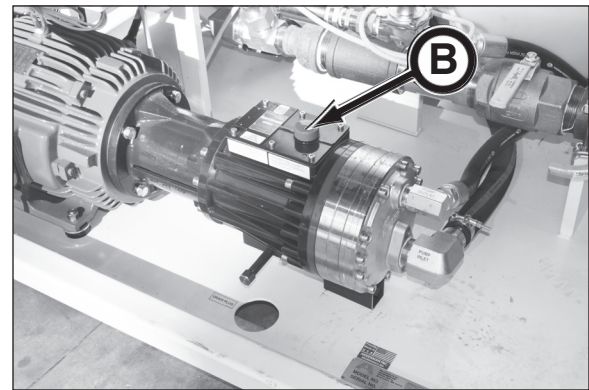

4. FLUSH & DRAIN WATER COOLING TANK COMPONENTS

In freezing weather, remove cap or hose from 3" outlet (C). Remove drain plug from pump (D). Flush and drain pump and all fluid lines. With water completely drained, replace plugs. Failure to do so will cause damage to pump components.

The tank must also be drained or add a RV anti-freeze solution in freezing weather unless a suitable heat source is used for keeping the tank temperature above freezing.

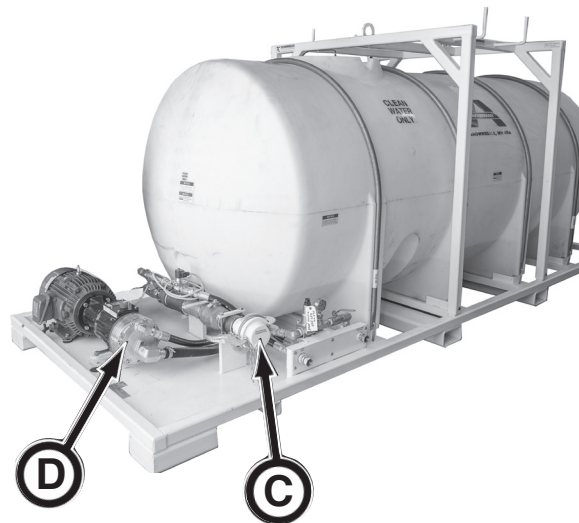

AFTER FIRST 100 HOURS, THEN EVERY 1000 HOURS OF OPERATION

5. DRAIN & FILL COOLING PUMP OIL

Drain and fill cooling pump (A) of oil as follows:

1. Clean area around check/fill cap (B) and gear case oil drain plug (C).
2. Loosen check/fill cap (B) for ease of draining oil. Remove gear case oil plug (C) and drain oil from gear case.
3. Replace gear case oil drain plug and remove check/fill cap.
4. Add 1.1 US quart (1.05 L) of a high quality SAE 10W-30 motor oil through check/fill port. Oil level should be:

1/4 in. (6 mm) from top of the fill port
5. Replace check/fill cap.

NOTICE Anytime the oil shows signs of contamination, drain oil and refill with clean oil.

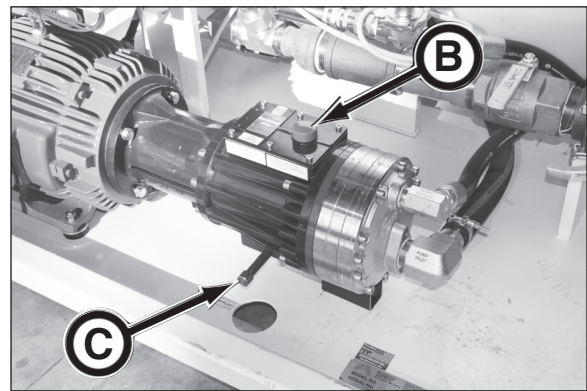
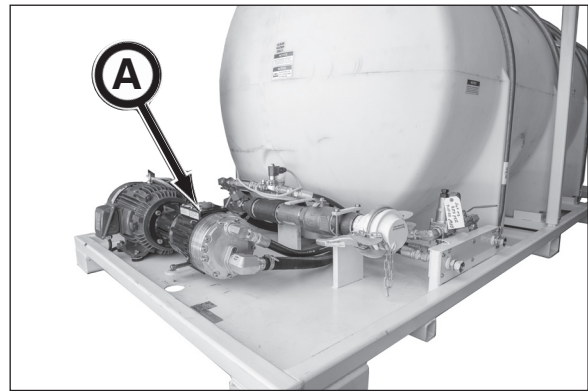

YEARLY OR EVERY 1000 HOURS OF OPERATION

6. DRAIN & FILL COOLING PUMP OIL

Drain and fill cooling pump (A) of oil as follows:

1. Clean area around check/fill cap (B) and gear case oil drain plug (C).
2. Loosen check/fill cap (B) for ease of draining oil. Remove gear case oil drain plug (C) and drain oil from gear case.
3. Replace gear case oil drain plug and remove check/fill cap.
4. Add 1.1 US quart (1.05 L) of a high quality SAE 10W-30 motor oil through check/fill port. Oil level should be:

1/4 in. (6 mm) from top of the fill port
5. Replace check/fill cap.

NOTICE Anytime the oil shows signs of contamination, drain oil and refill with clean oil.

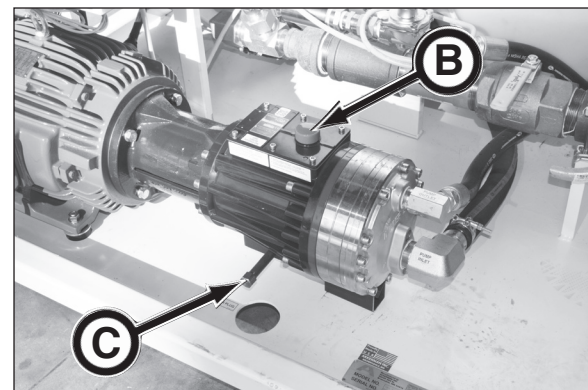
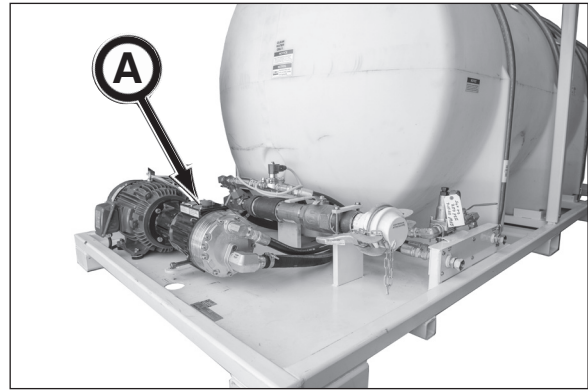

VI. Storage

PREPARING FOR STORAGE

1. Clean equipment thoroughly.
2. Repair worn or damage parts.
3. Repaint equipment where necessary.
4. Remove cap or hose from 3" outlet. Remove drain plug from pump. Flush and drain pump and all fluid lines. With water completely drained, replace plugs. If necessary, flush equipment with RV antifreeze to prevent freezing.
5. Inspect power cable for damage. Clean connections with electric contact cleaner and blow dry with compressed air. Use industrial strength bags to cover all cable connection ends, then tape the bags to the cable to prevent contamination.
6. Coil power cable neatly on the cooling tank power cable hangers.
7. If possible, store equipment under cover and out of the weather in a ventilated area.

REMOVING FROM STORAGE

1. Clean equipment thoroughly.
2. Check to make sure all decals including safety decals are clean and readable.
3. Check condition of wires and cables. Repair or replace as necessary.
4. Check for leaks. Repair or replace as necessary.
5. Fill water cooling system tank with clean water (refer to II. Setup and Operation).
6. Check condition of all hoses and connections. Tighten, repair or replace with new as needed.
7. Review this instruction for the cooling tank operation and maintenance.

VII. Troubleshooting

Problem	Cause	Solution
No flow from tank.	No power:	Connect control container to power source.
	A. 480V main disconnect is OFF.	Flip main disconnect to ON.
	B. Cooling pump disconnect is OFF.	Flip cooling pump disconnect to ON.
	C. Cooling tank power cable not connected to control container bulkhead connection.	Connect cooling tank power cable to container bulkhead.
	D. Control cable not connected or damaged cable.	Connect control cable from Cooling VFD Control on container to VFD connection on water tank control panel.
	E. An E-Stop button(s) is pushed in.	Pull out ALL E-Stop buttons.
	F. Cooling pump start/stop on control screen is in STOP mode.	Press cooling pump START button.
Motor and/or pump malfunction.	Motor and/or pump malfunction.	Repair or replace motor or pump.
	Water supply not connected or not turned on.	Connect water supply and/or turn supply on.
	Motor does not turn.	Check for VFD fault.
Pump flows are inconsistent.	External power source (generator) output is erratic.	Inspect and troubleshoot generator.
	Motor and/or pump malfunction.	Repair or replace motor or pump.
Pump flow is inadequate.	Flow rate not adjusted for project.	Readjust flow control. Additional flow required on long tunnels due to line loss.
	PRV not set properly.	Reset PRV valve.
The tank auto fill does not operate properly.	Float switch malfunction.	Repair or replace float switch.

VIII. Specifications

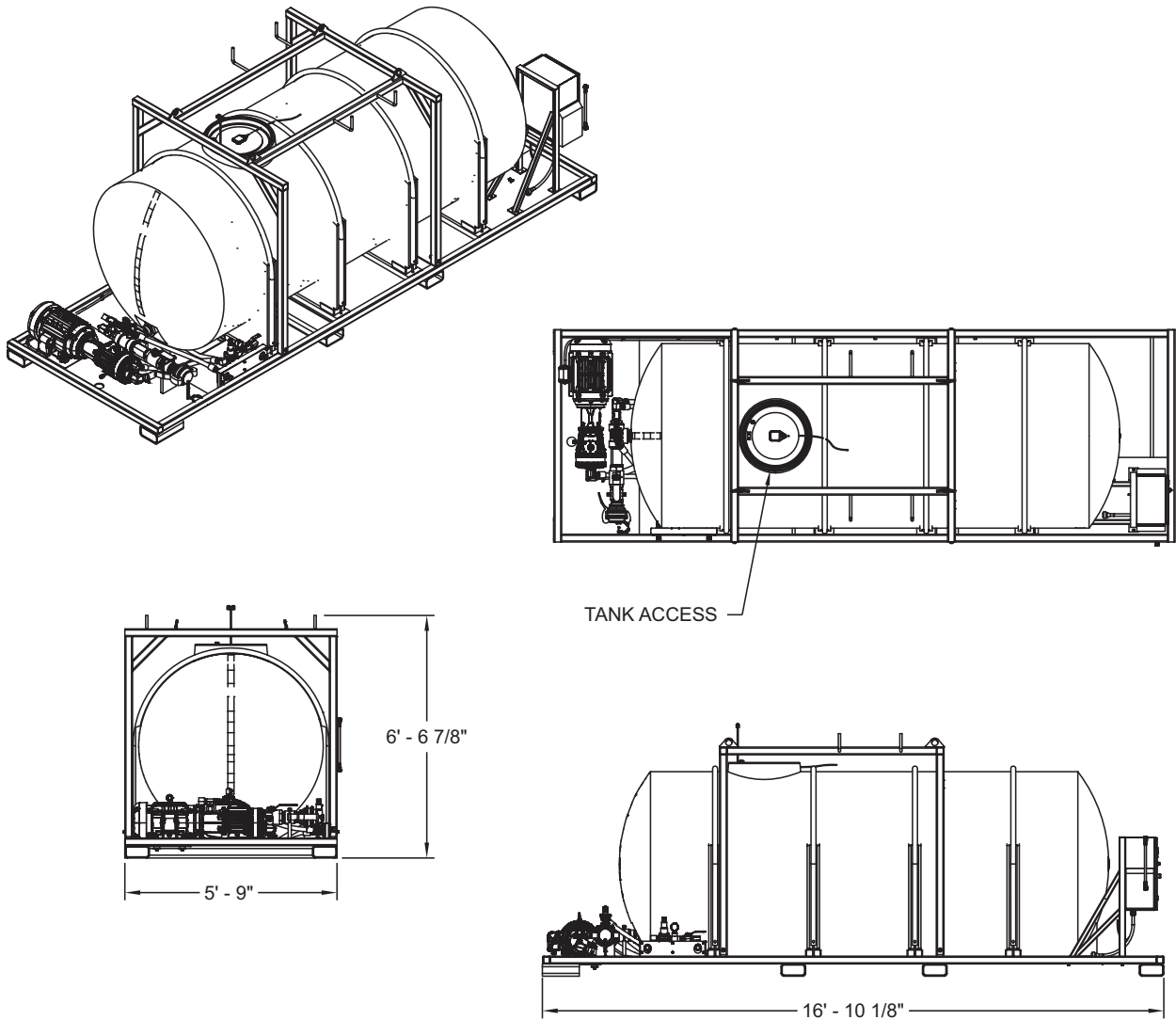

Tank Capacity	1,685 gallon (6,378 L)
Weight (Empty)	3,500 lbs. (1,588 kg)
Electric Motor Drive (Variable Speed / Variable Output)	7.5 HP @ 1200 RPM
Pump Maximum Flow	20 GPM
Pump Maximum Pressure	1,000 psi
Maximum Water Supply Inlet Pressure	100 psi
Automatic Fill Feature.....	Float Switch
Output Flow	Digital Readout

IX. Electrical Schematics

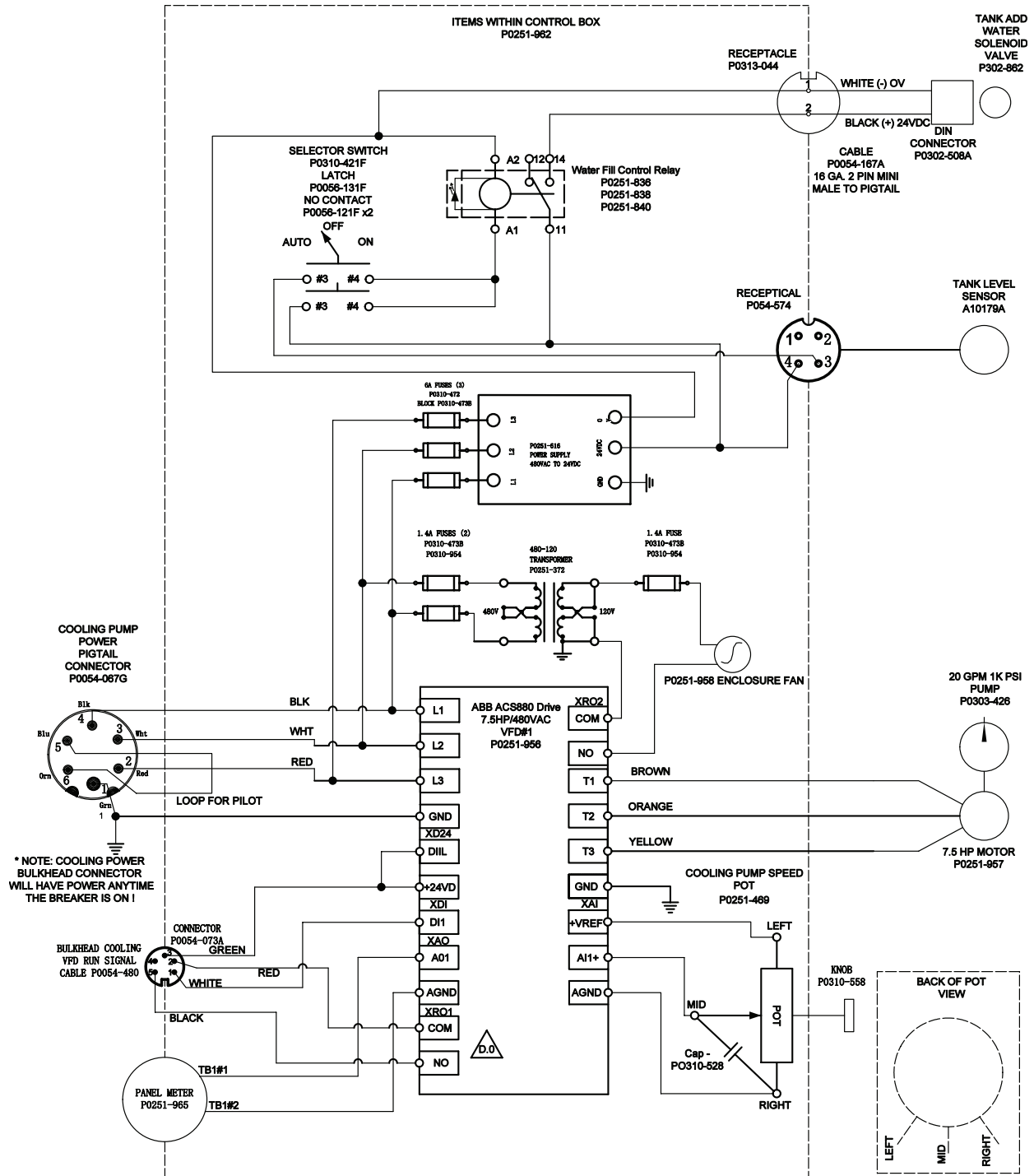

CONTROL CONTAINER COOLING CIRCUIT MODIFICATION FOR VFD DRIVEN COOLING PUMP FA10178F

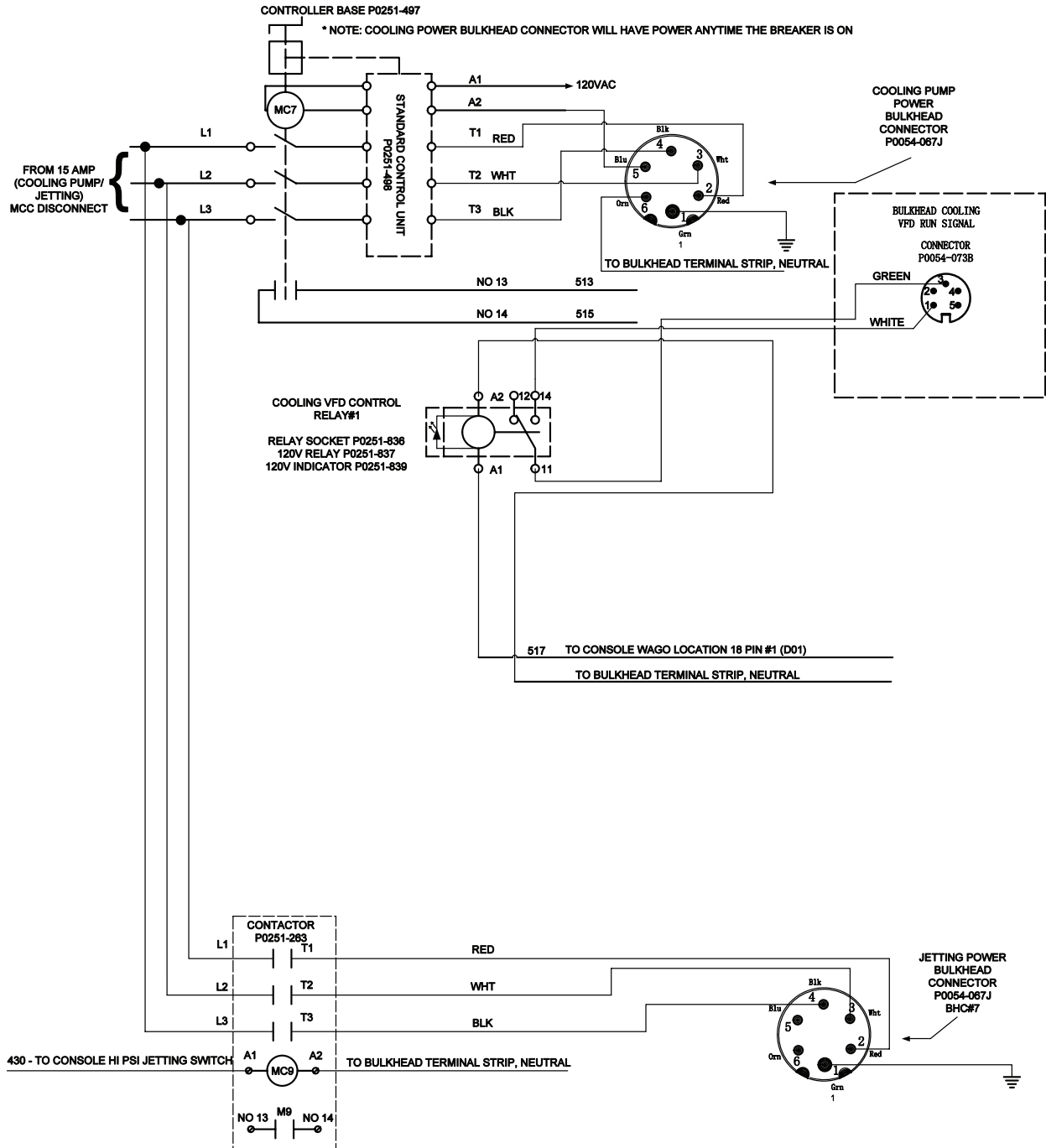

X. Warranty

Akkerman warrants that all equipment manufactured by it be free from defects due to workmanship or material when normally used and serviced for a period of 90 days from the date of shipment by Akkerman. Normal wear and tear to the equipment, including, but not limited to, wear on the cutter face tooling, hydraulic filters, augers, casings, slurry line and seals is not covered by this warranty. Akkerman does not warrant that the equipment meets the requirements of any particular safety code or rule governing equipment classification. If the Customer has questions about local safety codes, rules or ordinances, authorities local to the project should be consulted.

In order to be considered as a potential warranty claim, the component in question must be returned to Akkerman (freight prepaid) for factory inspection and analysis, and determination of warranty applicability. No warranty is provided for electronics or electrical components of any kind. The validity of all warranty claims are subject to the discretion and determination of the Akkerman Aftermarket Support Department. All such determinations are final.

XI. Identification Numbers

Model and serial numbers are required when ordering parts or requesting service information. Record your model and serial number below.

1685 0-20 GPM WATER COOLING TANK (A)

Model Number _____

Serial Number _____

