



# **OPERATOR'S MANUAL**

## **Tunnel Boring Machine 960B Wheel Machine**

**BH S/N: F30750F**

**Publication No. 050080A**

Rev No. 130228

Akkerman Inc. 58256 266th Street Brownsdale, MN 55918  
Phone: 507-567-2261 Fax: 507-567-2605 email: [akk@akkerman.com](mailto:akk@akkerman.com)

**SERVICE • RELIABILITY • INNOVATION**



# Introduction

This operator's manual contains important safety, operation, and maintenance information for your Akkerman Tunnel Boring Machine (TBM). You must read and understand this manual, your haul unit operator's manual, pump unit operator's manual, and your gas detection system operation manual before you operate and maintain this equipment. Keep this manual with your TBM at all times. Directions in this manual are referenced from the launch shaft going forward to the reception shaft, unless otherwise noted. Additional copies of this manual may be purchased from the Akkerman Aftermarket Support Department, or downloaded from the Akkerman web site at [www.akkerman.com](http://www.akkerman.com).

The contractor is responsible for the overall safety program on the job site. Use this manual as a part of the safety program.

The use of second rate parts could affect the efficient performance of the Tunnel Boring Machine. ALWAYS use genuine Akkerman parts.

Understand safety signal words, DANGER, WARNING, CAUTION, SAFETY INSTRUCTIONS, and NOTICE. When you see these words in this manual or on safety decals mounted on your equipment, follow the safety message to avoid personal injury and/or property damage.

**▲ DANGER** Indicates an extremely hazardous situation which, if not avoided, WILL result in death or serious injury.

**▲ WARNING** Indicates a potentially hazardous situation which, if not avoided, COULD result in death or serious injury.

**▲ CAUTION** Indicates a potentially hazardous situation, which, if not avoided, MAY result in minor or moderate injury. It may also be used to alert against unsafe practices.

**SAFETY INSTRUCTIONS** Usually consists of individual messages stating procedures or actions that must be followed for the safe operation of a product.

**NOTICE** Identifies potential property damage and important installation, operator, or maintenance information.



**Akkerman 960B Tunnel Boring Machine**

Pipejacking and tunneling is a type of "trenchless technology" that utilize a tunnel boring machine (TBM). The TBM is advanced through the ground by hydraulic jacking cylinders on a jacking frame or pump unit from the launch shaft. As the TBM is advanced, powerful hydraulic motors rotate an inner drum. A cutterhead or closed face attachment is connected to the drum. As it rotates, the attachment teeth excavate the face and the spoils fall into the drum. Scoops and paddles in the drum dump the spoils onto a conveyor which carries the material to the dirt bucket. Once the dirt bucket is full, the dirt bucket is removed from the pipeline via a haul unit to the unloading area in the launch shaft where the dirt bucket is hoisted out of the shaft and unloaded.

If you find any errors with this manual or know of ways to improve procedures, please let us know. Email your comments via the form on the Contact Us page of the Akkerman web site, or mail your suggestions to: Akkerman Inc, ATTN: Technical Publications, 58256 266th Street, Brownsdale, MN 55918.

Akkerman Inc. reserves the right to improve its products without notice or obligation.

# Contents

<b>Safety</b> .....	<b>1</b>	<b>Controls &amp; Instruments (continued)</b>	
Be Alert For Safety Information .....	1-1	Boring Head Control .....	4-5
Read Operator's Manual .....	1-1	Conveyor Controls .....	4-6
Wear Protective Clothing .....	1-1	Steering Controls .....	4-7
Lockout Power Before Servicing .....	1-2	Dirt Wing Control .....	4-8
Hydraulic Oil/Fluids Under Pressure .....	1-2	Drum Advance Cylinder Control .....	4-9
Beware of Suspended Loads .....	1-2	Motor Control Box .....	4-9
Keep Personnel Away From Moving Parts ....	1-3	Pit Box Controls & Indicators .....	4-10
Unauthorized Welding .....	1-3	Closed Face or Auxiliary Control .....	4-11
Regularly Clean/Inspect Equipment .....	1-3	Hydraulic Reservoir .....	4-12
Inspect Electrical Connections .....	1-3	Gear Ring Oiler .....	4-12
Using Tunnel Power Cable .....	1-4	Pressure Gauges .....	4-13
Contact With Power Cable .....	1-4	Hourmeters .....	4-13
Practice Safe Maintenance .....	1-4	Return Filter Indicators .....	4-14
Test Tunnel Ventilation .....	1-5		
Slippery When Wet .....	1-5	<b>Pre-Start Inspection</b> .....	<b>5</b>
Fire Prevention .....	1-5		
Conveyor Operation .....	1-6	<b>Operation</b> .....	<b>6</b>
Keep Away From Belt .....	1-6	Operating Guidelines .....	6-1
Keep Away From Auger .....	1-6	System Overview .....	6-3
Stay Away From Crane .....	1-7	Cutter Head Attachments .....	6-4
Keep Riders Off Haul Unit .....	1-7	Recommended Tools & Equipment .....	6-5
Avoid Tunnel Wall Contact .....	1-7	Site Planning .....	6-5
Watch For Conveyor .....	1-7	Site Preparation .....	6-6
No Smoking In Shaft Or Tunnel .....	1-8	System Set-Up .....	6-7
Keep Job Site Clean & Organized .....	1-8	Connecting Power Source To Pit Box & TBM ..	6-15
Lockout Power Before Servicing Haul Unit ...	1-8	Checkout Equipment Prior To Start-Up .....	6-18
Avoid Pinch Points .....	1-9	Using Emergency Stop .....	6-18
Avoid Laser Light Exposure .....	1-9	TBM Start-Up Procedure .....	6-19
Recycle Waste .....	1-9	Launching The Tunnel Boring Machine .....	6-23
		Operating The Conveyor .....	6-33
<b>Safety Decals</b> .....	<b>2</b>	Making Steering Adjustments .....	6-35
Tunnel Boring Machine, 960B		Accessing Front Of TBM /Encountering	
Left Side .....	2-1	An Obstruction .....	6-36
Right Side .....	2-2	Adjusting Overcut (Dirt Head Only) .....	6-36
Belt Conveyor .....	2-3	Adjusting TBM Roll .....	6-37
Laser Sight .....	2-4	Using Gas Detector .....	6-38
		Using Haul Unit .....	6-38
<b>Terminology</b> .....	<b>3</b>	Using Closed Face or Auxiliary Control .....	6-39
Tunnel Boring Machine		Adding Pipe .....	6-40
960B .....	3-1	Filling TBM Hydraulic Reservoir .....	6-45
TBM Control Valves .....	3-2	Daily Shut Down .....	6-46
Pressure Gauge Console .....	3-3	Removing TBM & Jacking System .....	6-47
Main Electrical Control Box .....	3-4		
Motor Control With E-Stop .....	3-5	<b>Transporting</b> .....	<b>7</b>
Pit Box .....	3-6	Transporting Guidelines .....	7-1
Cutter Head Attachments .....	3-7	Lifting Instructions .....	7-2
Conveyor - Belt .....	3-8		
Laser Light Stand .....	3-9	<b>Lubricants</b> .....	<b>8</b>
		Hydraulic Reservoir Lubricant .....	8-1
<b>Controls &amp; Instruments</b> .....	<b>4</b>	Electric Motor Bearing Grease .....	8-1
Emergency Stop .....	4-1	Grease .....	8-2
Gas Detector .....	4-1	Storing Lubricants .....	8-2
Main Power Switch .....	4-2		
Conveyor Safety Switch .....	4-3		
Power Phase Indicators .....	4-4		
Incoming Power Light .....	4-5		

(continued on next page)

<b>Periodic Maintenance.....</b>	<b>9</b>	<b>Storage .....</b>	<b>10</b>
Lubrication and Maintenance Intervals .....	9-1	Preparing For Storage .....	10-1
Before Performing Maintenance .....	9-1	Removing From Storage .....	10-1
Lockout Power Before Servicing .....	9-2		
Hydraulic Oil/Fluids Under Pressure .....	9-2	<b>Troubleshooting .....</b>	<b>11</b>
Avoid Pinch Points .....	9-2	TBM 960B .....	11-1
Welding .....	9-3	Conveyor .....	11-5
Maintenance Charts .....	9-4	TBM Hydraulic Schematic .....	11-6
<b>TBM .....</b>	<b>9-4</b>	Electrical Schematics	
Prior To Each Drive Launch .....	9-4	Electrical Control Box .....	11-7
Detailed Procedures .....	9-9	Motor Control Box .....	11-8
Daily or Every 10 Hours .....	9-5	Pit Box .....	11-9
Detailed Procedures .....	9-15		
Weekly or Every 50 Hours .....	9-6	<b>Specifications .....</b>	<b>12</b>
Detailed Procedures .....	9-22	Tunnel Boring Machine .....	12-1
Every 500 Hours .....	9-7	Conveyor .....	12-2
Detailed Procedures .....	9-25	Yoke .....	12-2
Every 1000 Hours .....	9-7	Skids .....	12-3
Detailed Procedures .....	9-26		
Annually .....	9-7	<b>Identification Numbers .....</b>	<b>13</b>
Detailed Procedures .....	9-27		
After Each Drive .....	9-8	<b>Material Safety Data Sheets .....</b>	<b>14</b>
Detailed Procedures .....	9-28		
<b>Belt Conveyor.....</b>	<b>9-30</b>	<b>Warranty .....</b>	<b>15</b>
Prior To Each Drive Launch .....	9-30		
Detailed Procedures .....	9-33		
Daily or Every 10 Hours .....	9-31		
Detailed Procedures .....	9-39		
Weekly or Every 50 Hours .....	9-32		
Detailed Procedures .....	9-44		

**NOTES**

# Safety

---

## BE ALERT FOR SAFETY INFORMATION

When you see this safety alert symbol on your equipment or in this manual, be alert to the possibility of personal injury or property damage.

Read all safety information.

Keep safety decals clean and in good condition. Replace missing or damaged safety decals.



**ATTENTION!  
BECOME ALERT!  
YOUR SAFETY IS INVOLVED!**

---

## READ OPERATOR'S MANUAL

**⚠️ WARNING** Unsafe operation or maintenance can cause severe injury or death.

Read and understand the Operator's Manual before operating or servicing this equipment.

Any unauthorized modifications will void the warranty.

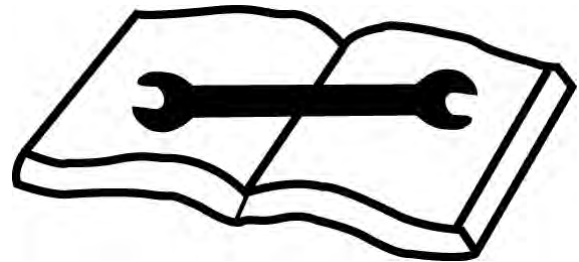

---

## WEAR PROTECTIVE CLOTHING

Wear OSHA approved protective clothing, such as hard hat, gloves, safety goggles, earmuffs or ear plugs, face shield, and steel-toed boots, when operating and servicing this equipment.

Wear reasonably close fitting clothing and remove jewelry before working on or near this equipment. This will help prevent the danger of catching them in moving parts or controls.



---

## LOCKOUT POWER BEFORE SERVICING

**⚠ WARNING** Failure to lockout power before servicing can cause severe personal injury or death.

This TBM contains high voltage electricity.

LOCKOUT main power supply before servicing. Electrical repairs must be performed only by a certified electrician.



---

## HYDRAULIC OIL/FLUIDS UNDER PRESSURE

**⚠ WARNING** Escaping oil or other fluids under pressure can penetrate your skin causing serious injury or death.

Release all pressure before performing maintenance or repairs. Never weld near pressurized fluid lines.

DO NOT use your hands to check for leaks. When searching for leaks, use a piece of wood or cardboard.

Contact medical help immediately if any oil or fluid is injected into your skin. A serious infection or reaction can emerge without proper medical treatment.



---

## BEWARE OF SUSPENDED LOADS

**⚠ WARNING** Suspended loads may fall and cause severe personal injury or death.

If a hydraulic hose from the boom of a crane or excavator breaks, the boom can fall instantly.

Do not enter area under or around a load.



---

## KEEP PERSONNEL AWAY FROM MOVING PARTS

**⚠ WARNING** Crushing hazard.  
Keep personnel away from inside of jacking frame.  
Failure to do so could result in serious personal injury or death.



---

## UNAUTHORIZED WELDING

**⚠ WARNING** Unauthorized welding can cause structural failure resulting in possible injury or death.

Do not weld on any structural member.  
Unauthorized welding or repair will void the warranty.

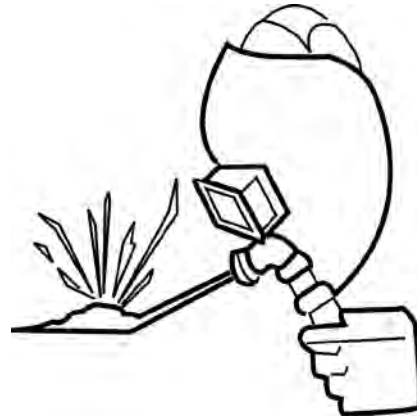

---

## REGULARLY CLEAN AND INSPECT EQUIPMENT

Remove any grease, oil, or debris buildup to avoid potential injury or equipment damage.

Inspect equipment for damage. If damaged, repair or replace immediately.

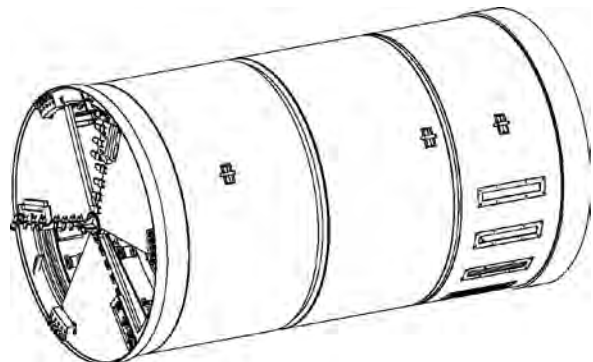

---

## INSPECT ELECTRICAL CONNECTIONS

**⚠ WARNING** Regularly inspect electrical connections to be sure they are secure. Failure to do so could cause an explosion if moisture enters an unsecured electrical connection.



---

## USING TUNNEL POWER CABLE

**⚠ DANGER** NEVER disconnect tunnel power cables when tunnel power is ON. Doing so WILL cause severe injury or death from electrical shock.



---

## CONTACT WITH POWER CABLE

**⚠ DANGER** Contact with a severed electrical cable WILL cause serious injury or death.

CONSTANTLY monitor electrical cables during drive to prevent cutting or stretching of any electrical cables.



---

## PRACTICE SAFE MAINTENANCE

**⚠ WARNING** Unexpected equipment movement may cause serious personal injury.

LOCKOUT power before performing any maintenance.

Shut down equipment before making repairs, adjustments, or removing obstructions.

Only trained and qualified personnel should perform any maintenance or repairs.

Keep the area around the equipment clean and dry when performing maintenance.

Do not service the machine while it is in motion.

Replace worn or damaged parts. Remove grease, oil, or debris buildup.

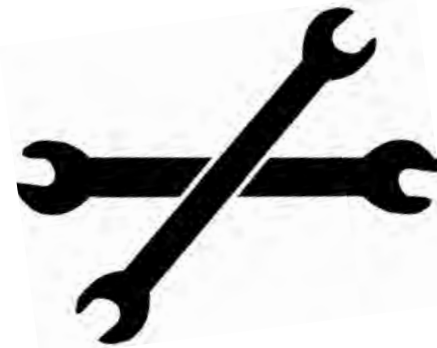

---

## TEST TUNNEL VENTILATION

**⚠ WARNING** Keep TBM, tunnel and shafts well ventilated at all times.

Use an approved air analyzer to detect hazardous gases and oxygen content.

Before and during the shaft operation, test for combustible and toxic gases and oxygen deficiency.

If the levels exceed OSHA prescribed levels, leave tunnel and shaft immediately! Do not activate or deactivate any electrical or hydraulic devices, since any sparks could cause an explosion.

Once ALL personnel are out of tunnel/shaft, cut power from power source.

Gases must be removed before reentering tunnel/shaft.

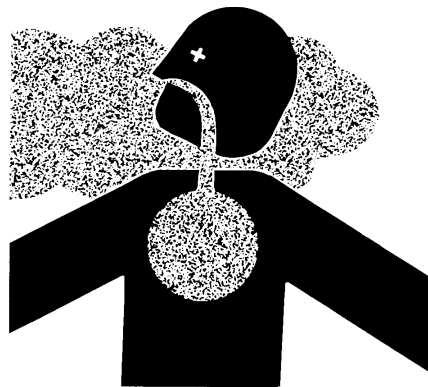

---

## SLIPPERY WHEN WET

**⚠ WARNING** Slips and falls can cause serious personal injury.

Ensure firm footing in wet or slippery conditions.

Replace skid-resistant material if it is damaged or missing to prevent slips and falls.

Remove any buildup of grease, oil, or debris.



---

## FIRE PREVENTION

**⚠ CAUTION** Fires can cause injury or property damage.

Keep equipment clean. Remove all debris from equipment.

Have a fire extinguisher available at all times. Keep the fire extinguisher fully charged.



---

## CONVEYOR OPERATION

**⚠ WARNING** Conveyor can jam in rotating cutterhead causing conveyor to swing into operator, resulting in severe personal injury.

While cutterhead is rotating:

1. Operator **MUST** remain seated in normal operating position.
2. Cutterhead drive dump valve (conveyor safety valve) **MUST** be tethered to conveyor.
3. ALL FOUR safety chains **MUST** be secured to conveyor.

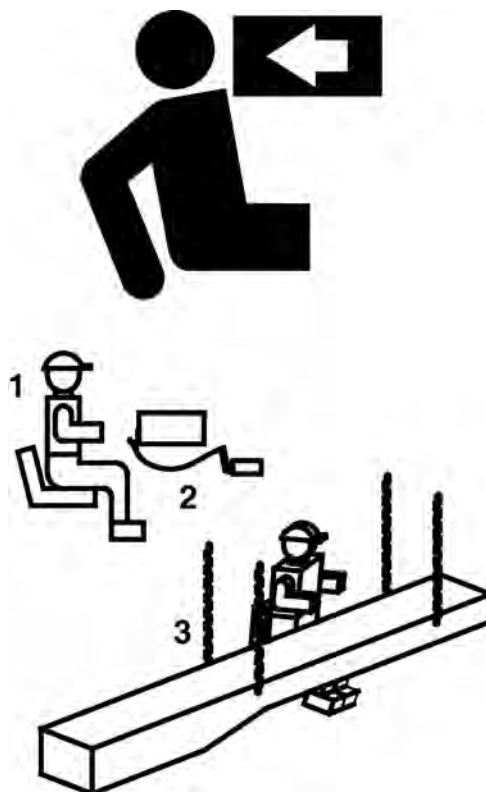

---

## KEEP AWAY FROM BELT CONVEYOR (IF EQUIPPED)

**⚠ DANGER** Contact with rotating conveyor belt or idler rollers will cause severe injury or death.

Keep hands, body, and objects clear of rotating conveyor.

Do not operate without covers and guards in place.

Lockout power before servicing belt conveyor.



---

## KEEP AWAY FROM AUGER (IF EQUIPPED)

**⚠ DANGER** Contact with rotating auger will cause severe injury or death.

Keep hands, body, and objects clear of operating auger.

Do not operate without covers and guards in place.

Lockout power before servicing.



---

## STAY AWAY FROM CRANE

**⚠ DANGER** Stay away from operating crane. If close to power lines, the crane, load, and ground may become electrified resulting in serious injury or death.



---

## KEEP RIDERS OFF HAUL UNIT

Allow only operator on operating seat when moving haul unit. Keep riders off.

Riders on haul unit can be easily injured by being struck by objects or being thrown off of the equipment. Riders can also obstruct the operator's view resulting in the equipment being operated in an unsafe manner.

A rider may be allowed in an empty dirt bucket (with contractor approval only), to transport personnel from the tunnel opening to the boring head. If allowed, the rider **MUST** be fully inside dirt bucket, including head and all other body parts, to avoid contact with obstructions. Also, rider cannot obstruct the operator's view.

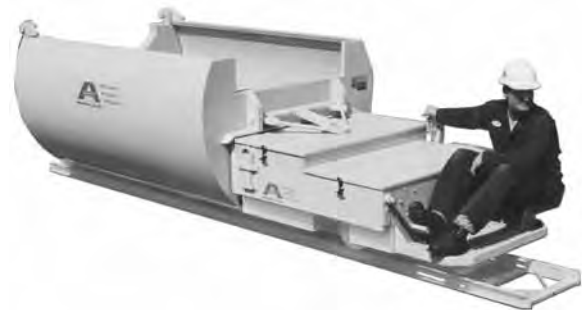

---

## AVOID TUNNEL WALL CONTACT

**⚠ WARNING** Contacting tunnel wall and other pipeline obstructions can cause severe personal injury or death.

Keep all body parts on haul unit while unit is moving.



---

## WATCH FOR CONVEYOR

**⚠ WARNING** Avoid contact with conveyor. Failure to do so could cause severe injury or death.

While moving haul unit into tunnel, avoid hitting the conveyor.



---

## NO SMOKING IN SHAFT OR TUNNEL

**⚠ WARNING** Smoking in shaft or tunnel could cause an explosion if combustible gases are present.

Do not smoke in shaft or tunnel.



---

## KEEP JOB SITE CLEAN AND ORGANIZED

**⚠ WARNING** Tripping can cause serious personal injury.

Be sure to keep job site clean and organized.



---

## LOCKOUT POWER BEFORE SERVICING HAUL UNIT

**⚠ WARNING** Failure to lockout power before servicing can cause severe personal injury or death.

Disconnect battery harness from contactor harness and remove battery pack from haul unit to LOCKOUT power before performing any maintenance.



---

## AVOID PINCH POINTS

**⚠ WARNING** Moving parts or the mishandling of parts can cause severe personal injury.

Keep hands away from moving parts.

Watch your fingers, hands, and legs while equipment is in operation.

Handle parts carefully to avoid crushing and pinch point hazards.



---

## AVOID LASER LIGHT EXPOSURE

**⚠ DANGER** Staring into laser light will cause severe injury.

Do not stare into laser guidance system light beam. Avoid direct eye exposure.

To avoid possible exposure to radiation in excess of acceptable emission limits, all repairs to laser must be performed by the original manufacturer or an authorized service technician.

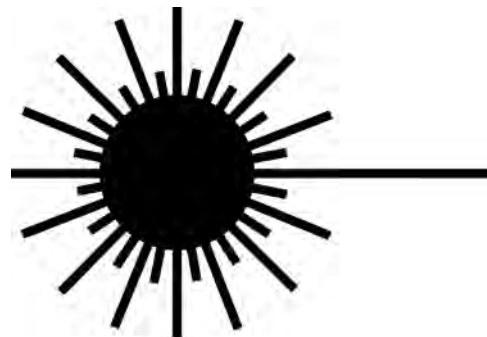

---

## RECYCLE WASTE

Follow local, state, federal, and international regulations when recycling or disposing of waste. Waste includes fluids/oil, fuel, filters, coolant, and batteries.

Use leakproof containers when draining fluids/oil. Do not pour waste on the ground, down a drain, or into any water source.

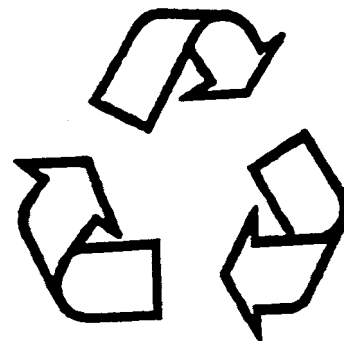

## **NOTES**

# Safety Decals

Keep all safety decals clean and readable. Use soft cloth, water, and a mild soap to clean the decals if they are too dirty to read. DO NOT clean safety decals with solvent. Solvent will damage the surface of the decal. Replace safety decals immediately if they are damaged, missing, or hard to read.

Serious injury or property damage can occur if safety instructions are not followed. Contact your Akkerman Aftermarket Support representative for free replacement safety decals.

If a part is replaced that has a safety decal on it, apply a new safety decal to the replacement part. Before applying a new decal, be sure the surface is clean and dry.

## TUNNEL BORING MACHINE - 960B - LEFT SIDE

**NOTICE**  
960B TBM LIFTING INSTRUCTIONS

**WARNING**  
Do not operate without guards in place.

**WARNING**  
Conveyer can jam in rotating, unshielded sawing conveyors to swing into operator, resulting in severe personal injury.

**NOTICE**  
Read and understand the Akkerman Boring operation and maintenance manual before attempting operation of this equipment.

**WARNING**  
While cutterhead is rotating:  
1. Operator MUST remain seated in normal operating position.  
2. Cutterhead drive dump valve MUST be fastened to conveyer.  
3. ALL FOUR safety chains MUST be secured to conveyor.

**NOTICE**  
Check grade and alignment often. To avoid excessive jacking pressure, gradually make any steering correction. Steering not must be free during right hand steering.

**WARNING**  
Unexpected jacking system movement may cause serious personal injury.

**WARNING**  
Shut down Pump Unit before making repairs, adjustments, or removing obstructions.

**WARNING**  
Keep Working Area and tunnel well ventilated at all times.  
Use an approved air analyzer to detect hazardous gases and oxygen content.

**NOTICE**  
GREASE DAILY, MORE OFTEN UNDER WET CONDITIONS

**WARNING**  
Tunnel boring machine (TBM) is top heavy. Any unintended movement may cause TBM to roll, resulting in serious injury or death upon contact. Use EXTREME caution while handling TBM in present rolling.

**NOTICE**  
Welding on TBM structure will damage the GASMAX gas detector.  
BEFORE performing authorized welding on TBM, remove the GASMAX gas detector by removing two mounting bolts and the four pin electrical connector.

**WARNING**  
PINCH POINTS! Watch your fingers, hands, and legs while equipment is in operation.

**WARNING**  
Tunnel boring machine (TBM) is top heavy. Any unintended movement may cause TBM to roll, resulting in serious injury or death upon contact. Use EXTREME caution while handling TBM to prevent rolling.

**NOTICE**  
CHANGE FILTER ELEMENT (S) WHEN INDICATED

**WARNING**  
PINCH POINTS! Watch your fingers, hands, and legs while equipment is in operation.

**EMERGENCY STOP**

**WARNING**  
Do not operate without guards in place.

**NOTICE**  
BEFORE operating TBM, the suction valve MUST be open and be strapped to prevent accidental closure of valve while operating.  
Attempting to operate the cutterhead with suction valve closed will damage the main drive pump.

**WARNING**  
Hazardous voltage. Disconnect and lock out power from source before servicing.

**WARNING**  
Contact with rolling tunnel boring machine (TBM) can cause serious injury or death.  
ALWAYS use cradles to secure TBM from rolling during transport.

**On Cradle**

# TUNNEL BORING MACHINE - 960B - RIGHT SIDE

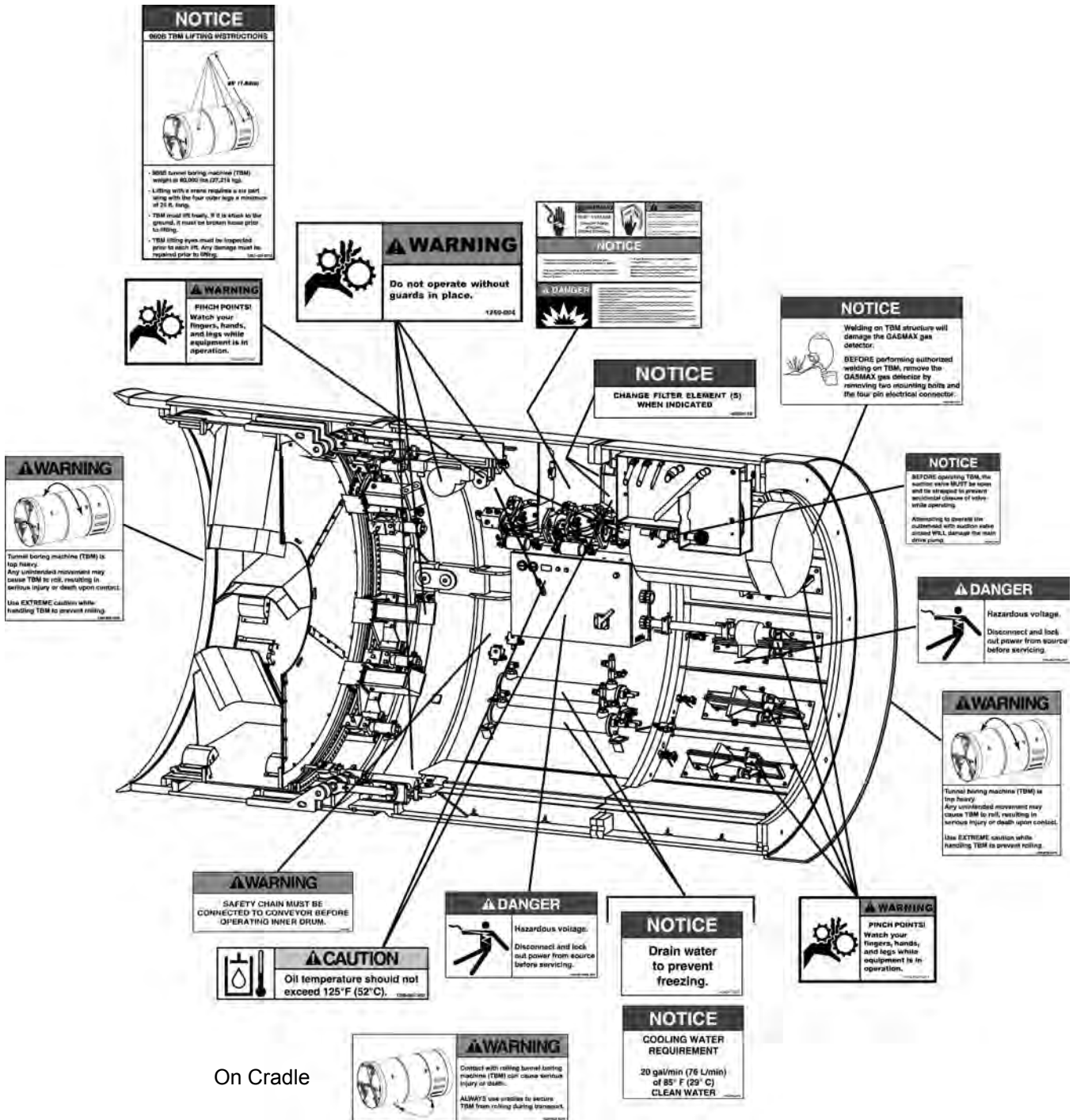

# BELT CONVEYOR

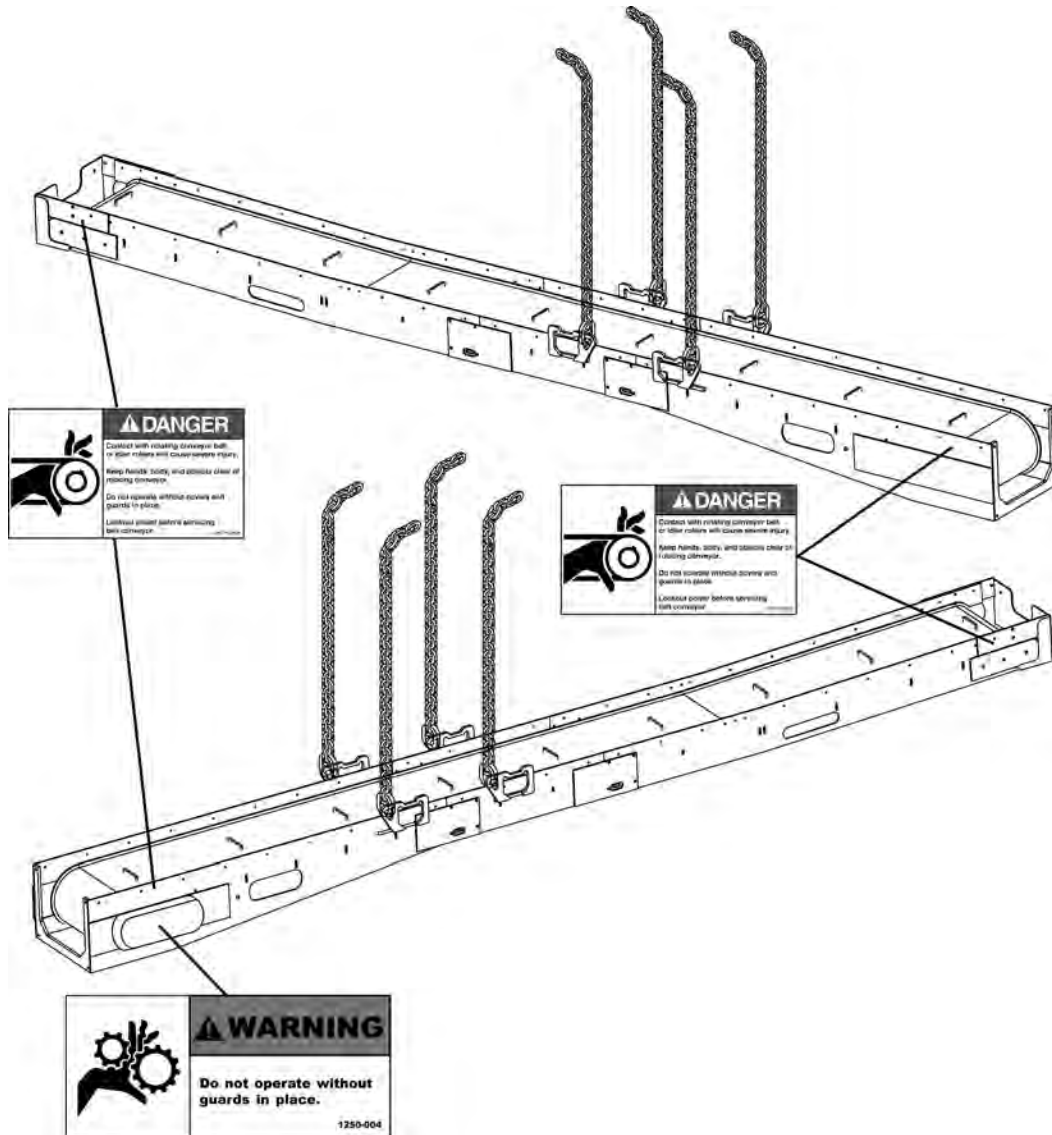

# LASER SIGHT

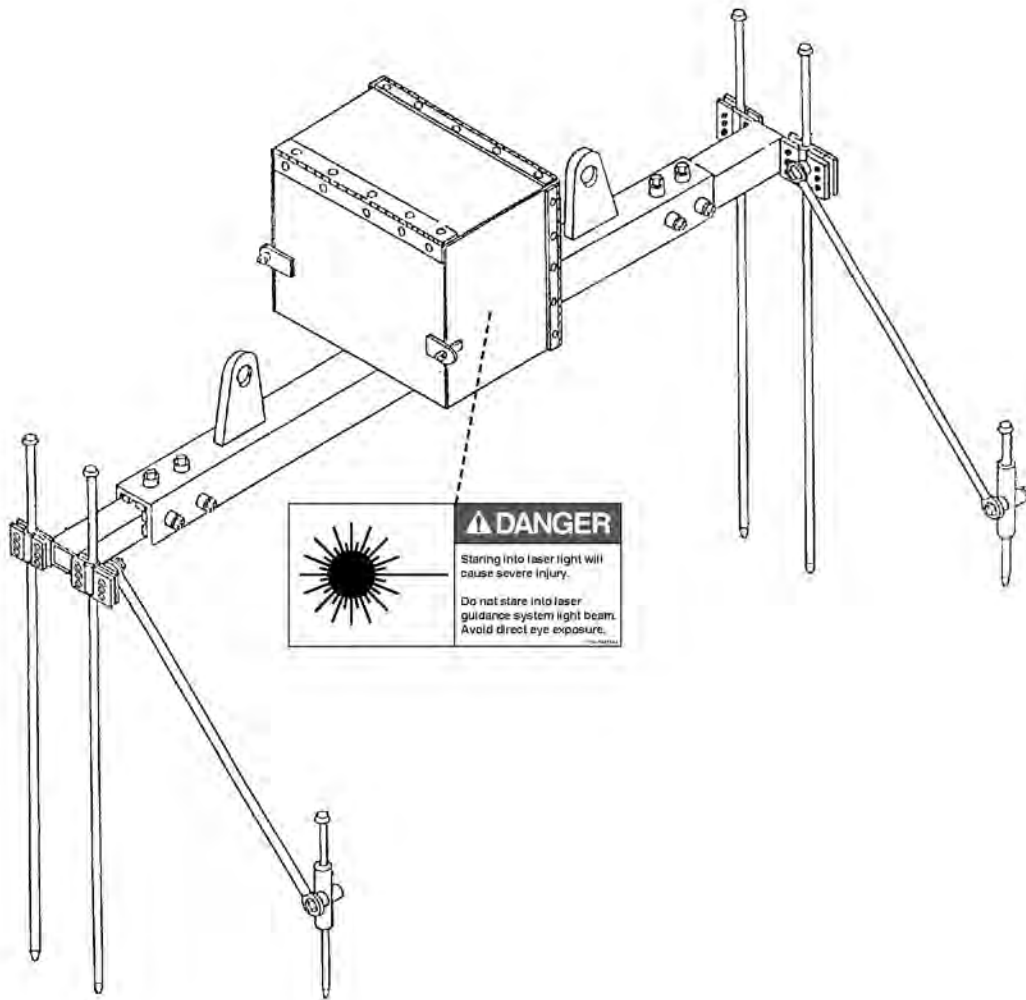

# Terminology

## TUNNEL BORING MACHINE - 960B

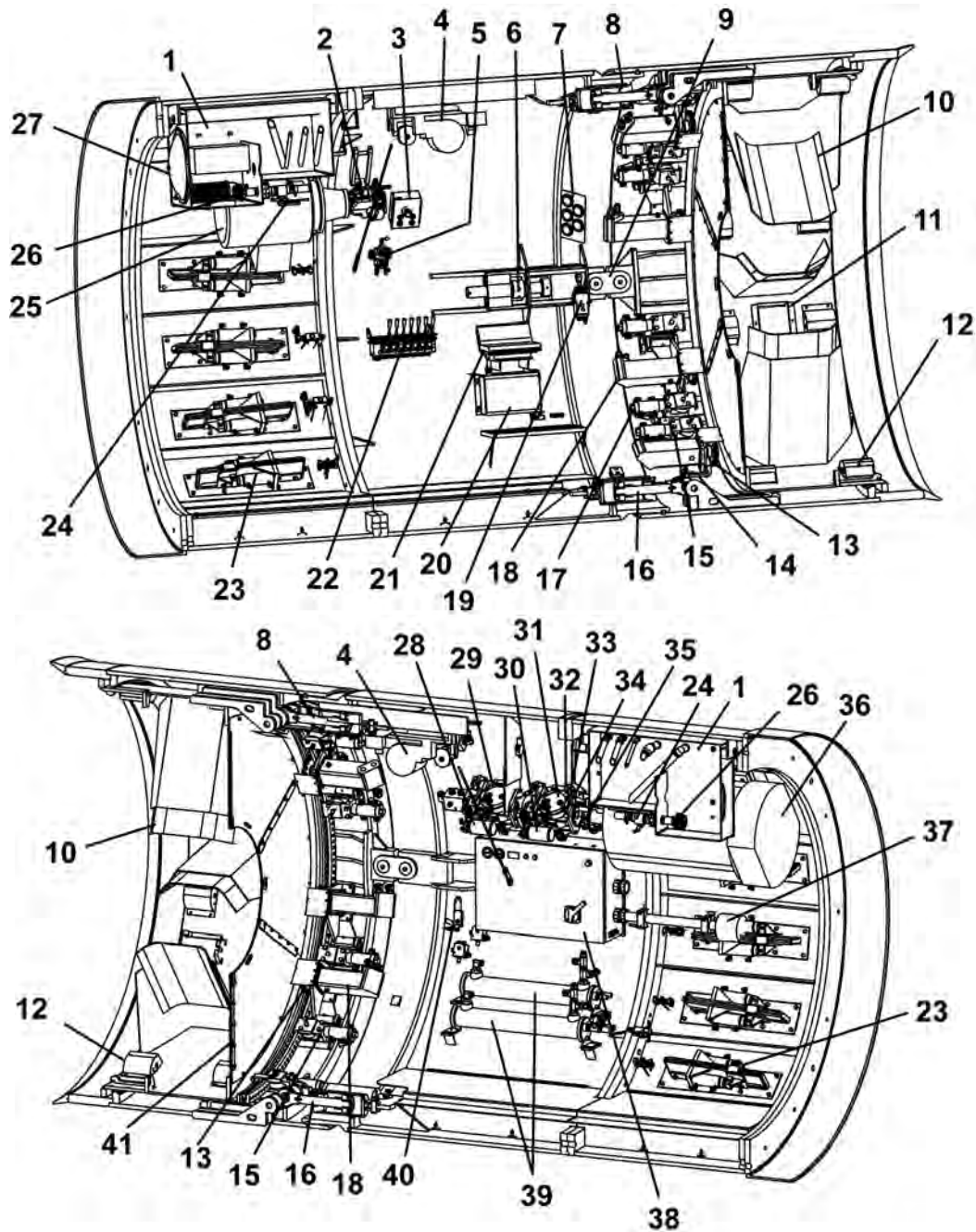

- |                                       |                                   |   |
|---------------------------------------|-----------------------------------|---|
| 1. Hydraulic Tank Reservoir 75 Gal.   | 15. Drum Advance Assembly         | 29. Boring Head Pump 2                  |
| 2. Auxiliary Pump                     | 16. Steering Cylinder (Bottom)    | 30. Boring Head Filter 1                |
| 3. Motor Control With E-Stop          | 17. Drum Advance Cylinder         | 31. Boring Head Pump 1                  |
| 4. Conveyor Lift Assembly             | 18. Drive Motor                   | 32. Auxiliary Pump Filter Indicator     |
| 5. Grade/Alignment Control            | 19. Boring Head/Conveyor Control  | 33. Boring Head Pump 1 Filter Indicator |
| 6. Steering Adjustment (Side to Side) | 20. Gear Ring Oiler Tank          | 34. Boring Head Pump 2 Filter Indicator |
| 7. Pressure Gauge Console             | 21. Operator Seat                 | 35. Gas Detection System                |
| 8. Steering Cylinder (Top)            | 22. TBM Control Valve             | 36. Boring Head Motor 200 HP            |
| 9. Steering Link                      | 23. Dirt Wing Cylinder Assembly   | 37. Incoming Power Connection           |
| 10. Dirt Paddle                       | 24. Boring Head/Aux Hyd. Shutoffs | 38. Main Electrical Control Box         |
| 11. Dirt Scoop                        | 25. Auxiliary Motor 50 HP         | 39. Hydraulic Oil Cooler                |
| 12. Drum Roller                       | 26. Boring Head/Aux Strainers     | 40. Conveyor Safety Switch              |
| 13. Drive Sprocket                    | 27. Reservoir Cleanout Cover      | 41. Bulkhead Seal                       |
| 14. Idler Roller                      | 28. Boring Head Filter 2          |   |

## TBM CONTROL VALVES

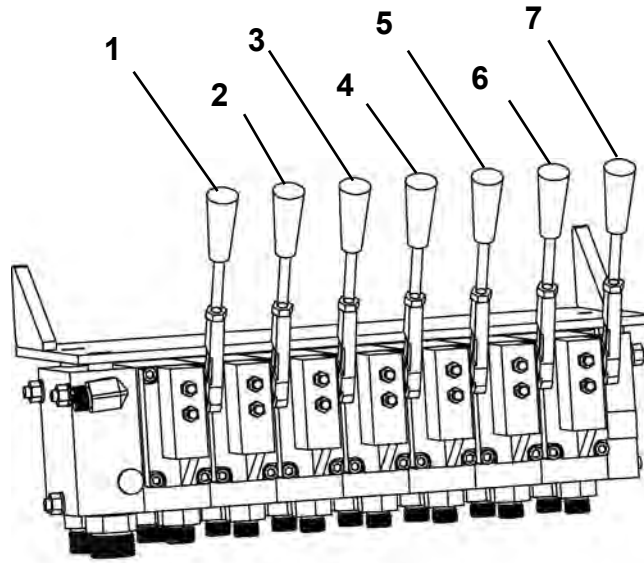

- |                           |                           |
|---------------------------|---------------------------|
| 1. Conveyor Drive         | 5. Steering Cylinders     |
| 2. Dirt Wings 1           | 6. Conveyor Lift          |
| 3. Dirt Wings 2           | 7. Drum Advance Cylinders |
| 4. Closed Face/ Auxiliary |                           |

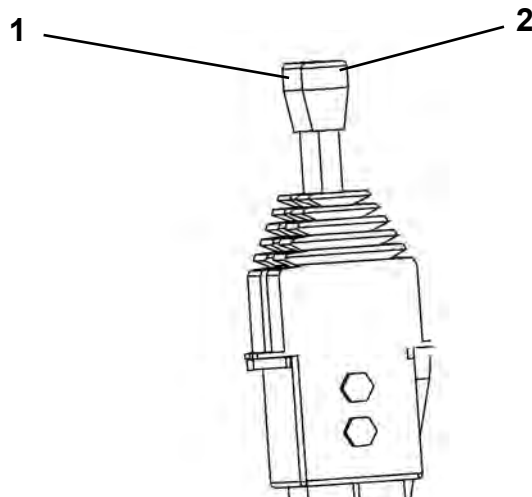

- |                      |
|----------------------|
| 1. Conveyor Drive    |
| 2. Boring Head Drive |

---

## PRESSURE GAUGE CONSOLE

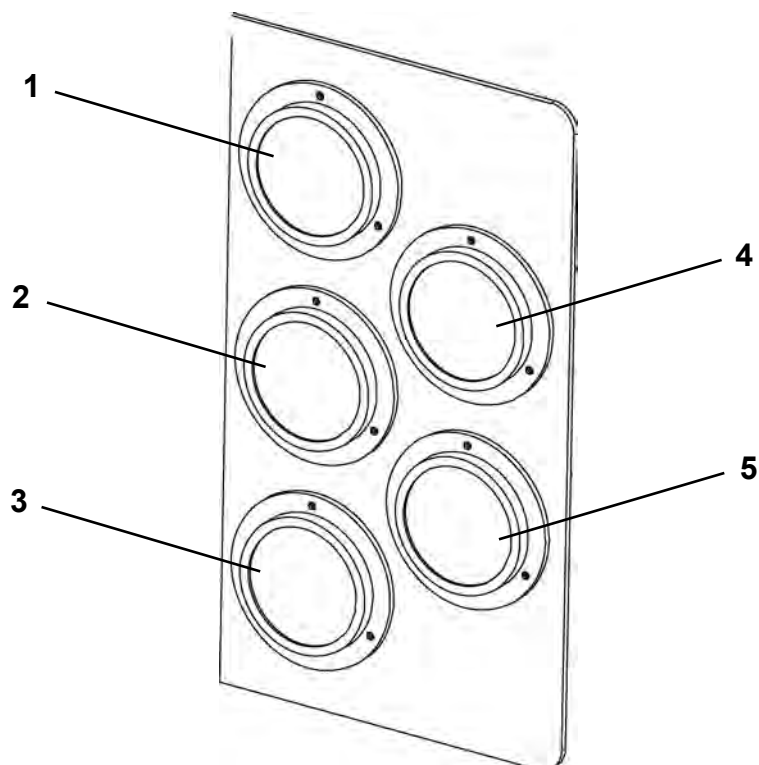

- 1. Auxliary Pressure Gauge
- 2. Boring Head CW Pressure Gauge
- 3. Boring Head CCW Pressure Gauge

- 4. Steering Cylinder Top Pressure Gauge
- 5. Steering Cylinder Bottom Pressure Gauge

## MAIN ELECTRICAL CONTROL BOX

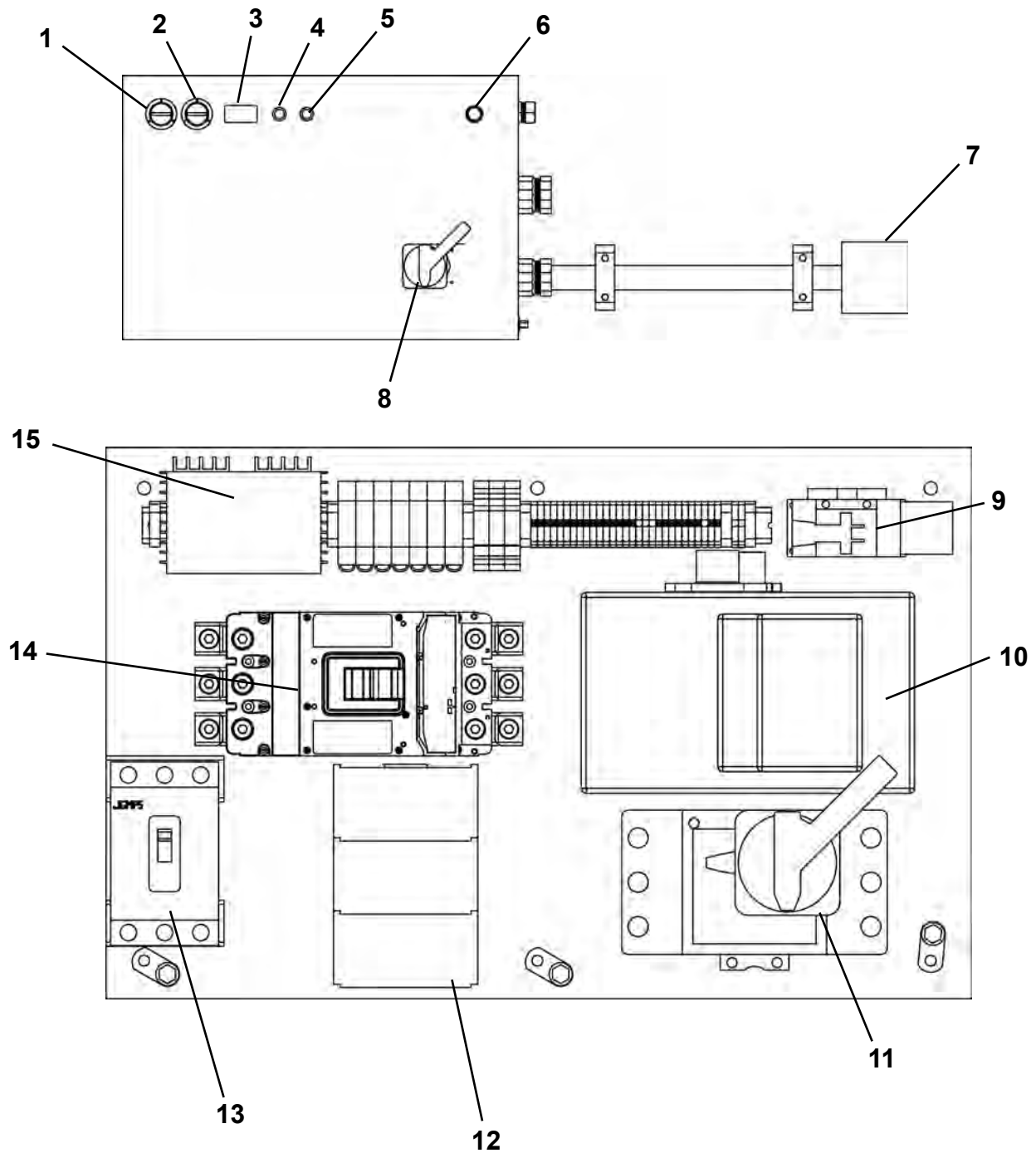

- |   |                                      |
|---|--------------------------------------|
| 1. Boring Head Motor Hourmeter          | 9. Auxiliary Motor 50 HP Contactor   |
| 2. Auxiliary Motor Hourmeter            | 10. Boring Head Motor Soft Start     |
| 3. Temperature Display                  | 11. Main Power Disconnect            |
| 4. Hydraulic Tank Empty Level Indicator | 12. Power Distribution Block         |
| 5. Conveyor Safety Switch Indicator     | 13. Auxiliary Motor Breaker          |
| 6. Incoming Power Indicator             | 14. Boring Head Motor 200 HP Breaker |
| 7. Tunnel Power Cable Connection        | 15. 24V Transformer                  |
| 8. TBM Main Power Switch                |                                      |

---

## MOTOR CONTROL WITH E-STOP

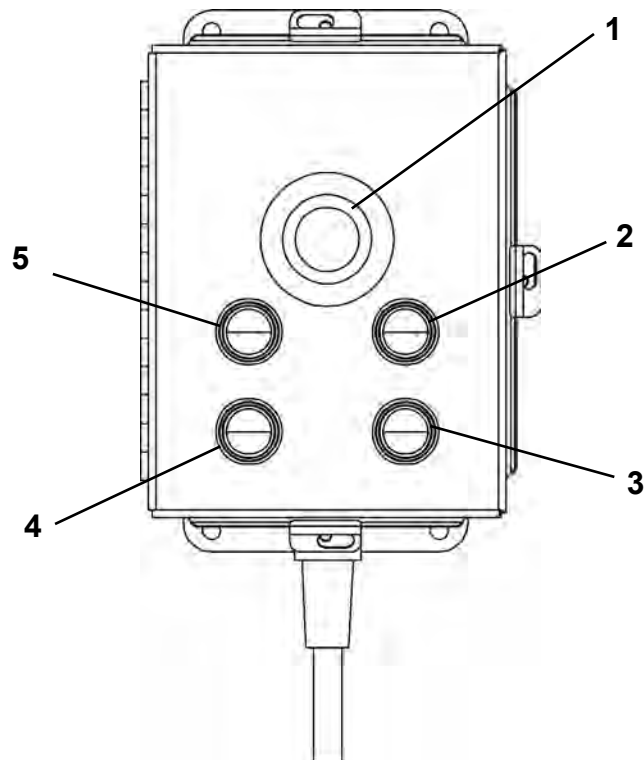

1. E-Stop Button
2. Auxiliary Motor 50 HP Start Button
3. Auxiliary Motor 50 HP Stop Button
4. Boring Head Motor 200 HP Stop Button
5. Boring Head Motor 200 HP Soft Start Button

## PIT BOX

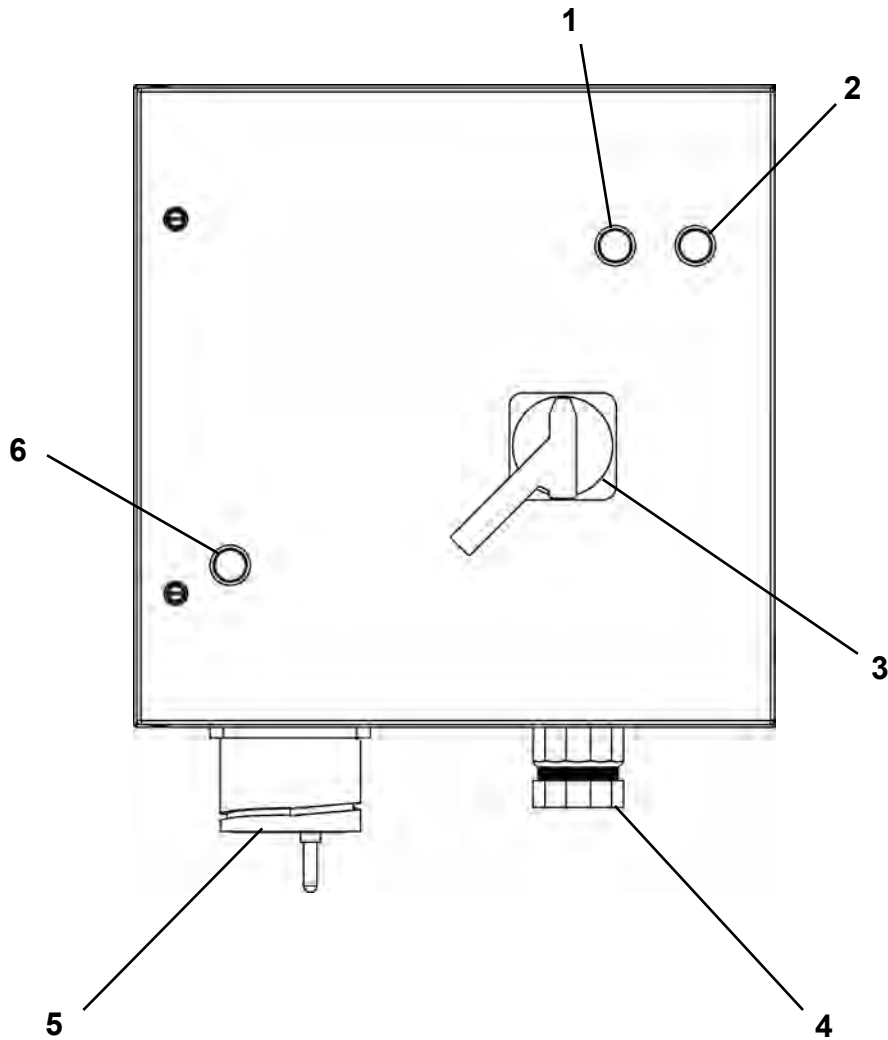

1. Power Phase OK Indicator - Green
2. Power Phase Error Indicator - Red
3. Main Power Disconnect
4. External Power Cable Connection
5. Tunnel Power Cable Connection (Pit Box To TBM)
6. Tunnel Power Light

# CUTTER HEAD ATTACHMENTS

**Dirt Head**

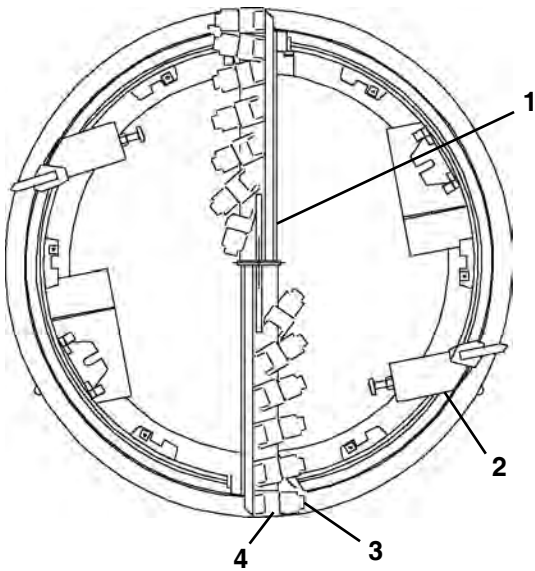

**Quad Carbide Bar Head**

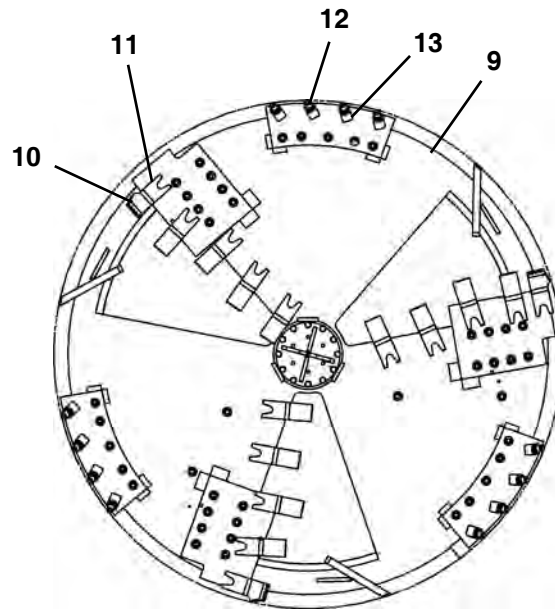
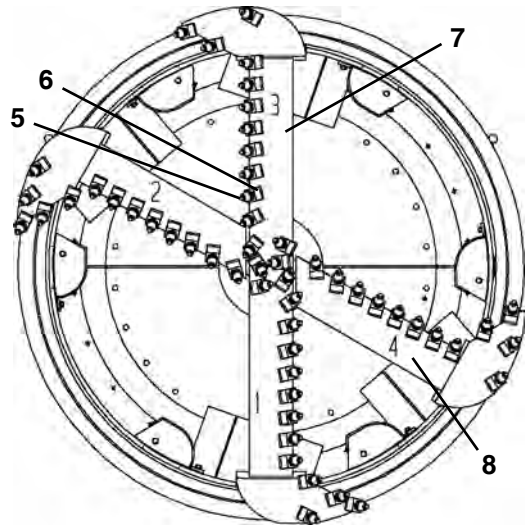

**Closed Face**

**Dirt Cutter**

- 1. Cutter Bar
- 2. Adjustable Cutter
- 3. Tooth Cutter
- 4. Tooth Pocket

**Quad Carbide Bar Head**

- 5. Carbide Tooth
- 6. Tooth Holder
- 7. Cutter Bar Weldment
- 8. Quad Bar Weldment

**Closed Face**

- 9. Closed Face
- 10. Cutter Tooth
- 11. Tooth Pocket
- 12. Cutter Bit
- 13. Bit Holder

## CONVEYOR - BELT

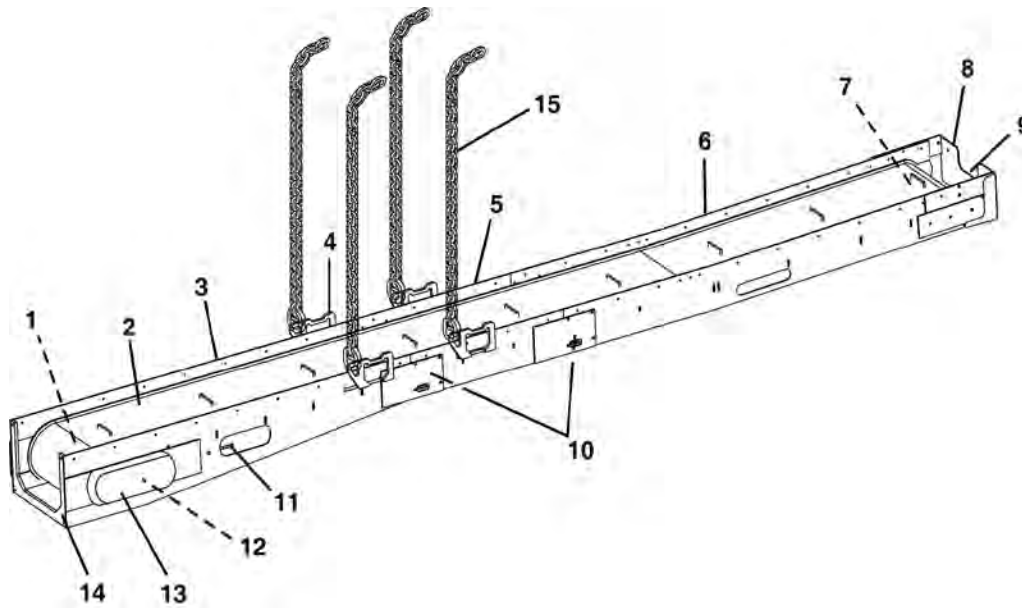

- 1. Drive Motor Frame Assembly
- 2. Belting
- 3. Drive Frame Assembly
- 4. Lift Bracket
- 5. Extension Frame Assembly

- 6. Feed Frame Assembly
- 7. Front Roller Assembly
- 8. Dirt Guard
- 9. Carrier Bearing
- 10. Idler Roller

- 11. Belt Tensioning Screw
- 12. Drive Motor & Roller Assembly
- 13. Conveyor Chain Cover
- 14. Drive Frame Free End Support
- 15. Safety Chain

## LASER LIGHT STAND

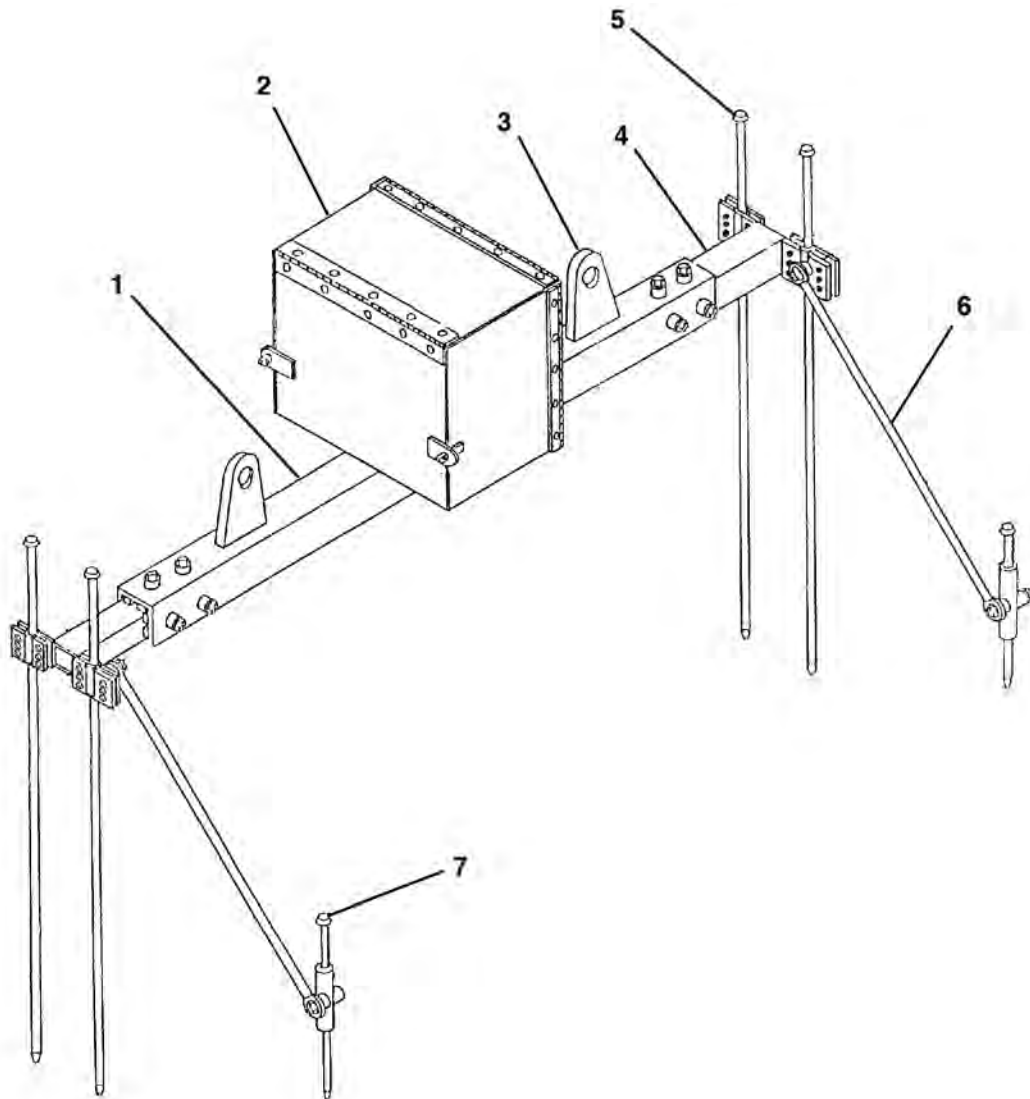

- 1. Adjustable Frame
- 2. Laser Box Assembly
- 3. Lift Bracket
- 4. Sliding Tube

- 5. Long Stake
- 6. Support Tube
- 7. Short Stake

## **NOTES**

# Controls & Instruments

## EMERGENCY STOP

**⚠ WARNING** Emergency Stop buttons MUST be tested and operating properly BEFORE operating Pump Unit and TBM. Failure to do so may cause severe injury or death.

Push E-Stop button (A) IN to stop all TBM electrical and hydraulic functions.

The E-Stop button will illuminate when it is pulled OUT.

The E-Stop button must be pulled out to restart operation.

The operating lights will not be functional when an E-Stop button is pushed IN.

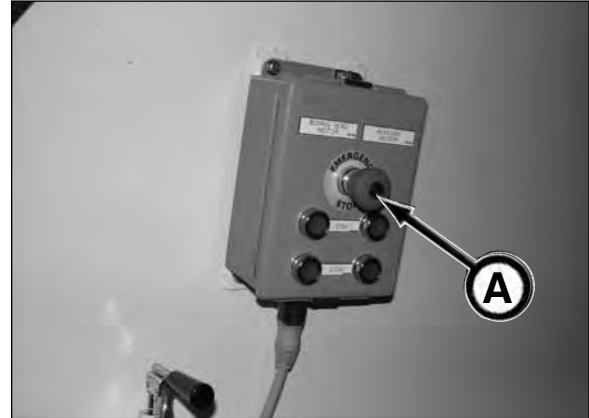

## GAS DETECTOR

**NOTICE** Refer to Akkerman Gas Detection System Operation & Parts Manual for operation and maintenance procedures.

**⚠ DANGER** The gas detection system installed in the TBM, monitors only methane gas levels. **Monitoring of all gas levels is the responsibility of the contractor.** This includes the accumulation of combustible and toxic gases, and depletion of oxygen. The contractor must keep the tunnel ventilated with fresh air.

The gas detection system includes the following primary components; the gas sensor, and transmitter/relay. The Akkerman system also provides a power supply for the system, and an audible and visual alarm system.

The transmitter has a LED/LCD display (B), depending upon the model of your gas detector. During normal operation, the current gas concentration is displayed. It is also used to display/scroll messages when in calibration mode or when a sensor fault is detected.

The four magnetic sensor controls are activated by a magnetic wand. Holding the magnetic wand over one of the magnetic sensor targets will activate that sensor. It may take several seconds for the magnetic sensor to activate. If the transmitter does not respond, remove the magnetic wand for several seconds and try again.

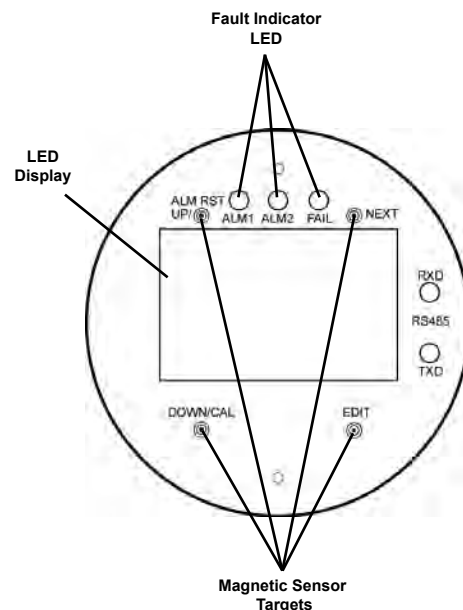
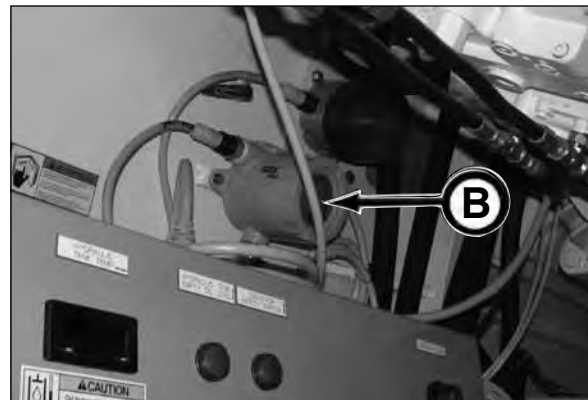

## MAIN POWER SWITCH

**⚠ DANGER** Hazardous voltage. Disconnect and lock out/tag out power from source before servicing.

**⚠ DANGER** If high voltage cables or cable connections are damaged, contact with cables/connections may result in electrical shock causing severe injury or death. Disconnect and lock out/tag out power from source before servicing.

**⚠ WARNING** Any electrical work performed on the pump unit or TBM must be completed by a certified electrician.

**NOTICE** All Emergency Stop buttons must be pulled out to restart operation.



Use the main power switch (A) on the TBM electrical box to provide power from the power source and pit box (B) to the TBM electrical components as follows:

1. With the power cables properly installed to the pit box (refer to Connecting Power To Pit Box in section 6, Operation) and the input power in proper phase (green light (C) is illuminated), lock out, tag out power on the pit box and external power source. If the red phase light (D) is illuminated, the phase power is incorrect. Two of the generator power leads must be reversed.

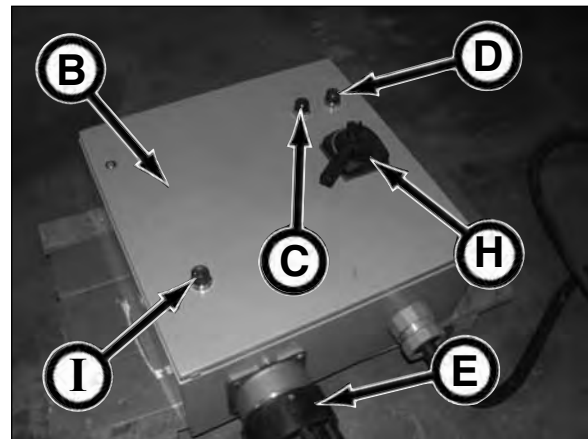

**IMPORTANT: DO NOT start up electric components if the red Power Phase Error light is illuminated. Doing so will run components backwards causing damage.**

2. Install the 480V power cable (E) from the pit box to the Incoming Power connection (F) from the TBM electrical box and the cable (G) from the E-Stop/Boring Head Motor/Auxiliary Motor control is connected to the electrical box.
3. Pull out all E-Stop buttons.
4. Turn on external power source with proper phase.
5. Turn pit box main power switch (H) to the ON position.
6. Check to be sure Tunnel Power light (I) is on.
7. Then check to be sure the incoming power light (J) on the electrical box is on. If the light is illuminated, turn on main power switch (A).
8. Once main power switch is turned to the ON position, the 480V power provides power to the 200 HP boring head motor and the 50 HP auxiliary motor. The 480V circuit also powers a transformer inside the electrical box which converts the 480V power to 24 VDC. The 24 VDC circuit provides power for the lights, gas detector empty level sensor, temperature sensor and the conveyor safety valve circuit.

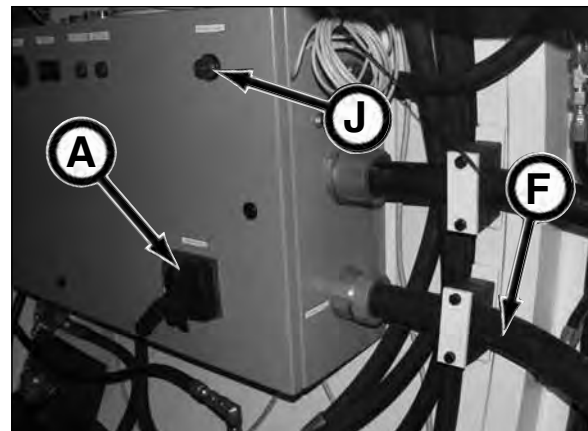

## CONVEYOR SAFETY SWITCH

The conveyor safety switch light (A) will illuminate when the tethered chain to the conveyor is pulled by excessive conveyor movement and trips the conveyor safety switch (B).

When the conveyor safety switch trips, the cutter head stops rotating.

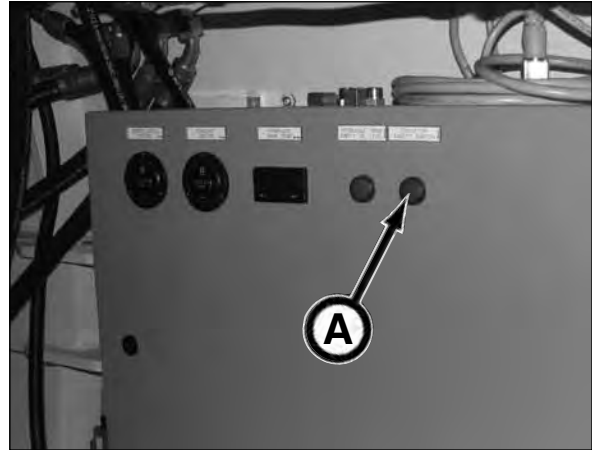

To reset the conveyor safety switch and to resume cutter head rotation, flip the valve lever down to the operation position (C).

Location (D) indicates the valve lever in the tripped position.

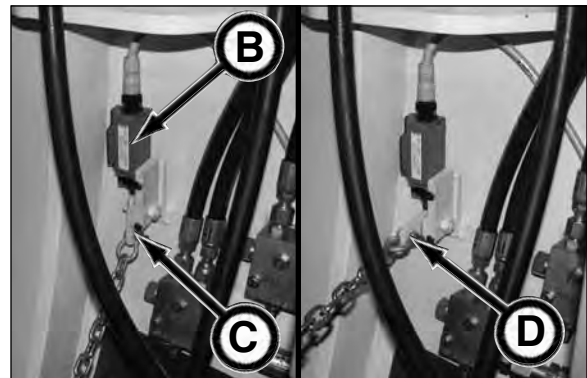

*Operation Position*

*Tripped Position*

## POWER PHASE INDICATORS

**⚠ WARNING** Any electrical work completed on the TBM must be performed by a certified electrician.

**IMPORTANT: DO NOT** start up electric motors if the red Phase Error light (B) is illuminated. Doing so will run motors backwards causing component damage.

The input power is monitored for proper three phase electrical power.

If the green Phase OK indicator light (A) is illuminated, this indicates that the external power source is installed correctly and that the main power in the TBM can be turned on providing the pilot circuit is complete (refer to Incoming Power Light in this section).

If the red Phase Error indicator light (B) is illuminated, this indicates that the external power source phase power is installed incorrectly. A certified electrician must disconnect and lock out tag out ALL power before attempting to reverse the two generator power leads.

The Phase Error light will also illuminate in the following conditions:

- Undervoltage (Less than 95%)
- Overvoltage (greater than 110%)
- Phase imbalance
- Phase loss

If it becomes necessary to troubleshoot the electrical fault, the 960B TBM is equipped with a Phase Detector (includes fault indicators). Gain access to the Phase Detector ONLY if it is required to help diagnose electrical issues. Lock out power, then open the pit box electrical cover to gain access to the Phase Detector (C).

Refer to the table to the right for the Phase Error LED status indicator codes. The LED status light is located on the inside of the main disconnect electrical box.

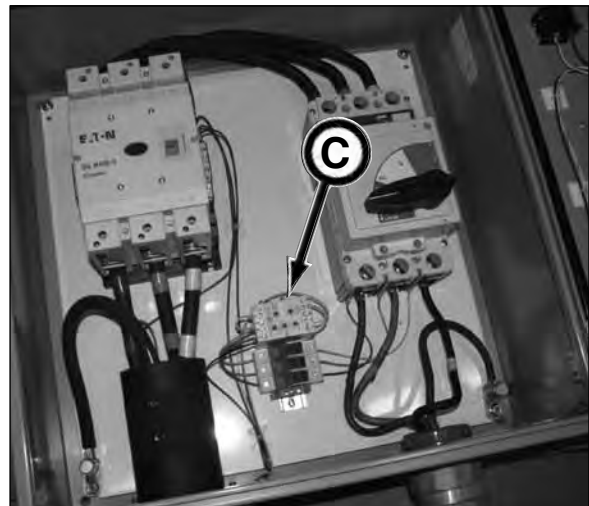
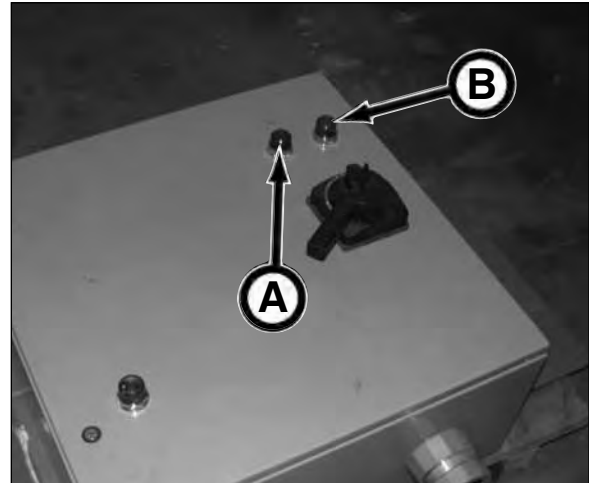

FAULT INDICATION CODE TABLE	
Led Status	Indicator
Green Steady	Normal / Relay ON
Green Flashing	Power Up / Restart Delay
Red Steady	Unbalance
Red Flashing	Under Voltage / Overvoltage
Amber Steady	Reversal
Amber Flashing	Loss
Green/Red Alternating	Under / Overvoltage Trip Pending
Red/Amber Alternating	Nominal Voltage Set Error

## INCOMING POWER LIGHT

The incoming power light (A) will illuminate when power is available from the power source and pit box.

There is a pilot circuit that must be complete before power is available in the TBM:

1. Power cable from power source connected to pit box.
2. Power cable from pit box to incoming power connection in TBM.
3. Mini power cable from electrical box to Boring Head/Auxiliary Motor control box connection.
4. E-Stop on motor control box must be pulled out.

Once the pilot circuit is complete, with the power source and pit box power switches to the ON position, the Tunnel Power light (B) on pit box and Incoming Power light on TBM electrical box will illuminate, indicating power is available and the TBM is available for use.

**IMPORTANT: BEFORE STARTING, be sure the green (Phase OK) indicator light is illuminated. Starting up electric components with the red (Phase Error) indicator light illuminated will run components backwards causing damage.**

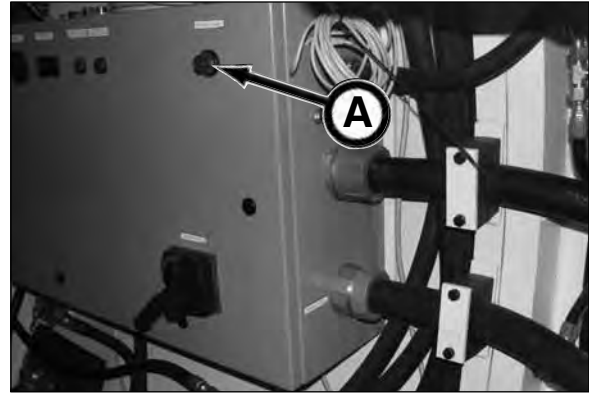

## BORING HEAD CONTROL

The Boring Head Control lever (C) controls the cutter head rotation. Move the lever as follows:

- PUSH - CW rotation\* (mining operation)
- PULL - CCW rotation\*

\* as viewed from operator seat, inside TBM

**NOTICE** Verify the control direction before mining.

The further the lever is moved from neutral, the faster the cutter head will rotate.



## CONVEYOR CONTROLS

### **Conveyor Lift**

The conveyor lift control (A) on the TBM control valve raises and lowers the conveyor. Move the control lever as follows:

- PUSH - raises conveyor
- PULL - lowers conveyor

### **NOTICE**

Do not over-raise the conveyor. If conveyor is completely raised when the steering cylinders are retracted, damage will result to conveyor and/or conveyor cables.

### **Conveyor Drive & Speed Control**

The conveyor drive lever (B) controls the forward/reverse direction and speed of the belt or auger conveyor. An additional conveyor drive & speed control (C) is located on the TBM control valve (7 bank valve), though this control is not equipped with the friction detent function.

The further the lever is moved from neutral, the faster the conveyor belt or auger will move. This control also is equipped with a friction detent, so the lever will remain in the desired position until you move it back to neutral position.

Move the lever as follows:

- PUSH - forward (towards reception shaft)
- PULL - reverse (towards launch shaft)

Control the speed of the conveyor so when the spoils drop on the conveyor, they do not pile up on the belt or in the auger. A change in TBM advancement rate or ground conditions will require an adjustment in the conveyor speed.

### **WARNING**

Running the conveyor too fast can cause severe injury from flying debris and cause possible machine damage. Slow the conveyor speed so there is continual controlled movement of the spoils into the dirt bucket.

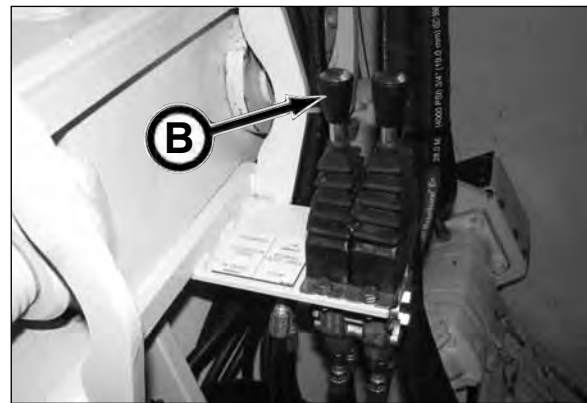
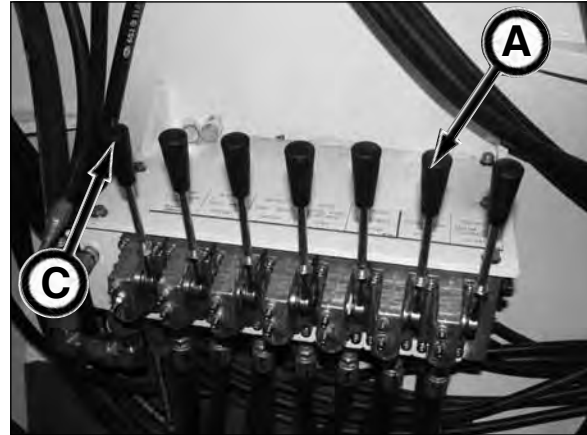

## STEERING CONTROLS

The steering controls include the steering selector (A), steering cylinder control (B), and steering adjustment nut (C).

When steering corrections are necessary, be sure to **make ONLY minor adjustments**. Making more extreme steering adjustments will increase the jacking forces due to the front and trailing sections are not in parallel.

### **Steering Selector**

Use the steering selector (A) to select the grade or alignment adjustment.

#### *GRADE (up/down)*

Move steering selector UP to select GRADE, then operate the steering cylinder control to adjust the steering cylinders. Once adjustment is made, move steering selector to Neutral position.

#### **NEUTRAL**

Move selector to middle position or Neutral to prevent accidental engagement of steering cylinders.

#### *ALIGNMENT (left/right)*

Move steering selector DOWN to select Alignment. Once adjustment is made, move steering selector to Neutral position.

*Left turn:* PULL (extend) steering cylinder control (B) while turning steering adjustment nut (C) forward.

*Right turn:* PUSH (retract) the steering cylinder control (B) while turning steering adjustment nut back.

### **Steering Cylinder Control**

The steering cylinder control lever (B) on the TBM control valve controls the extend and retract movement of the steering cylinders.

### **Steering Adjustment Nut Assembly**

The steering adjustment nut assembly (C) provides right to left manual steering adjustments by rotating the nut forward or backwards.

A steering wrench (D) may be used to rotate nut, otherwise relieve pressure on the nut by slightly moving steering cylinders and rotate nut by hand.

### **PRESSURE GAUGES**

The top steering cylinder pressure gauge (E) and bottom steering cylinder pressure gauge (F) indicate the active cylinder pressure. The maximum steering cylinder pressure to make steering corrections is 2,800 - 3,000 psi.

**IMPORTANT: DURING TBM ADVANCEMENT, DO NOT ALLOW STEERING CYLINDER PRESSURES TO EXCEED 3,000 PSI. DOING SO WILL CAUSE STRUCTURAL DAMAGE.**

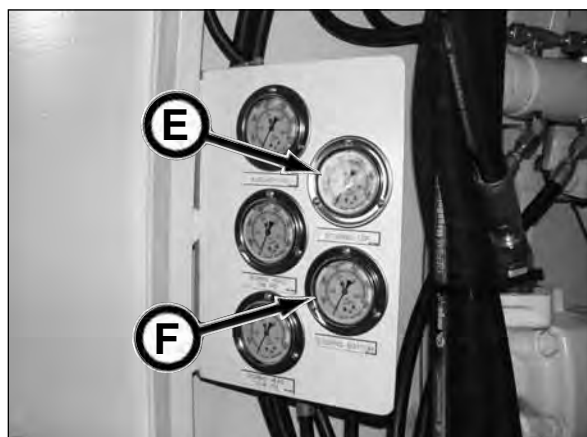
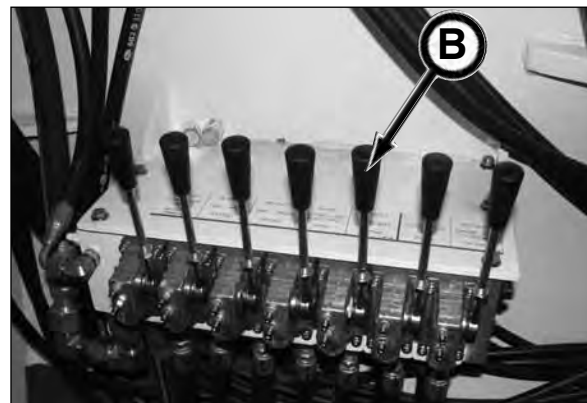
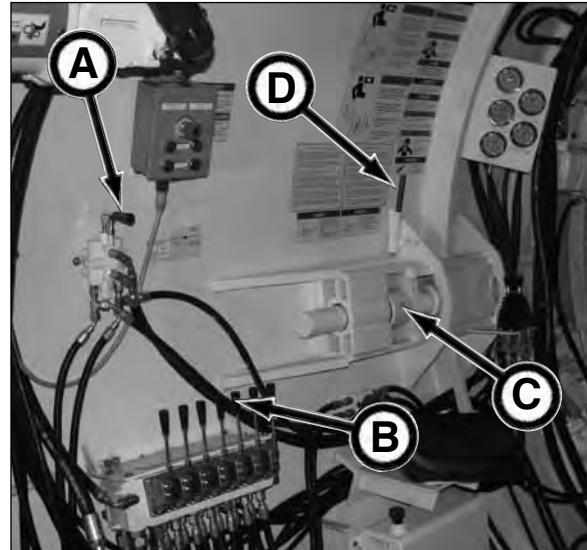

## DIRT WING CONTROL

The dirt wings (A) are used to control the TBM roll. If the TBM rolls 1/4 to 1/2" (6.35 to 12.7 mm) from level, dirt wings need to be extended.

There are various dirt wing configurations available for installation on the TBM. Contact your Akkerman Aftermarket Support representative for more information.

### *Extend Dirt Wings (B or C)*

Pull control lever (B or C) to extend dirt wings. The dirt wings are fully extended when the auxiliary pressure gauge (D) reads 2,800 - 3,000 psi.

### *Retract Dirt Wings (B or C):*

Pull control lever (B or C) to extend dirt wings. The dirt wings are fully retracted when the auxiliary pressure gauge (D) reads 2,800 - 3,000 psi.

Use the dirt wings as needed until the TBM roll is back to level position. The further the lever is moved from neutral, the faster the dirt wings will extend or retract.

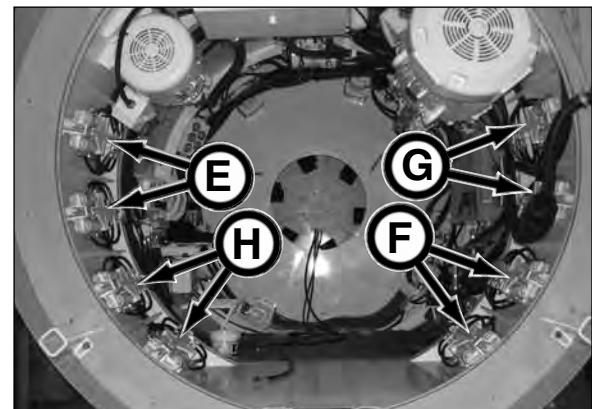
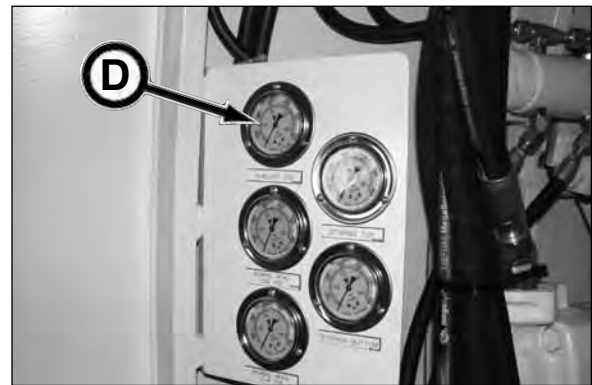
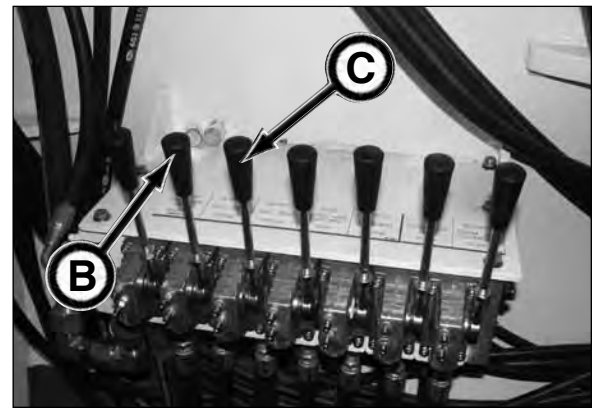
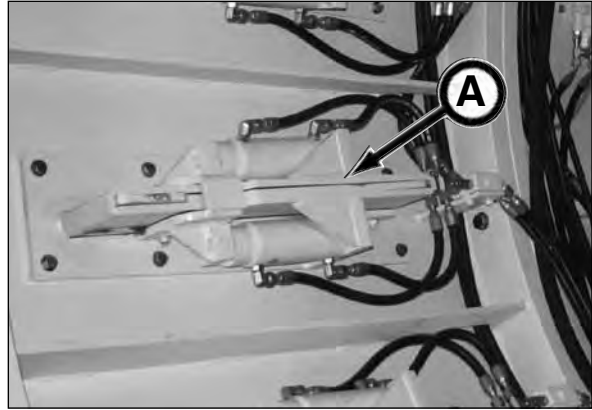

### CW Roll Control

Dirt Wing Control (B) will regulate the top two left dirt wings (E) and the bottom two right dirt wings (F). Using this control will roll the TBM in a CW direction.

### CCW Roll Control

Dirt Wing Control (C) will regulate the top two right dirt wings (G) and the bottom two left dirt wings (H). Using this control will roll the TBM in a CCW direction.

## DRUM ADVANCE CYLINDER CONTROL

The drum advance cylinders (A) move the inner drum in and out to allow front access to the machine in the event an obstruction is encountered or cutter teeth require replacement.

Use the Drum Advance Cylinder control lever (B) to regulate the drum advance cylinders as follows:

- PUSH - Retract drum advance cylinders
- PULL - Extend drum advance cylinders

Before launching TBM, fully extend the drum advance cylinders and retract the inner drum approximately 1/2" (13 mm). The drum advance cylinder full extension is 2.25" (57 mm).

**NOTICE** When using sand shelves, advance cylinders must be fully retracted. Extending advanced cylinders with sand shelves installed WILL cause damage to the inner drum.

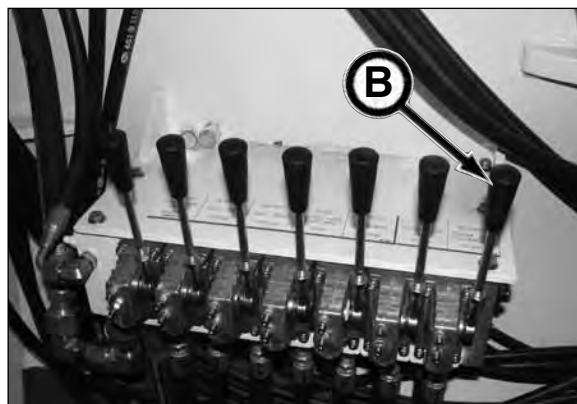
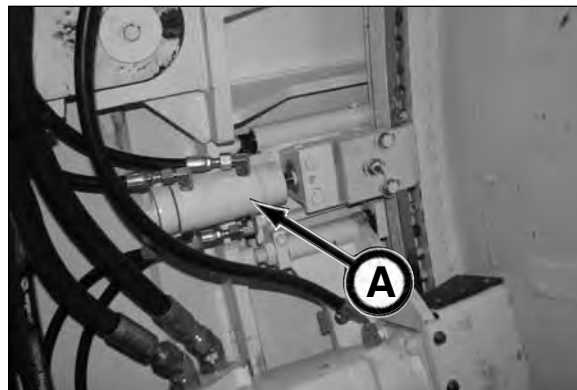

## MOTOR CONTROL BOX

The motor control box starts and stops the auxiliary 50 HP motor and the boring head 200 HP motor.

The boring head 200 HP motor is equipped with a soft start\* to eliminate the hard starting of the boring head motor.

**Auxiliary Motor**  
 Start Button (C)  
 Stop Button (D)

**Boring Head Motor**  
 Start Button (E)  
 Stop Button (F)

The motor control box also includes the E-Stop button (G):

Push E-Stop button IN to stop all TBM electrical and hydraulic functions.

The E-Stop button will illuminate when it is pulled OUT.

E-Stop button must be pulled out for motor operation.

\* For more information, refer to the Soft Starter User Manual.

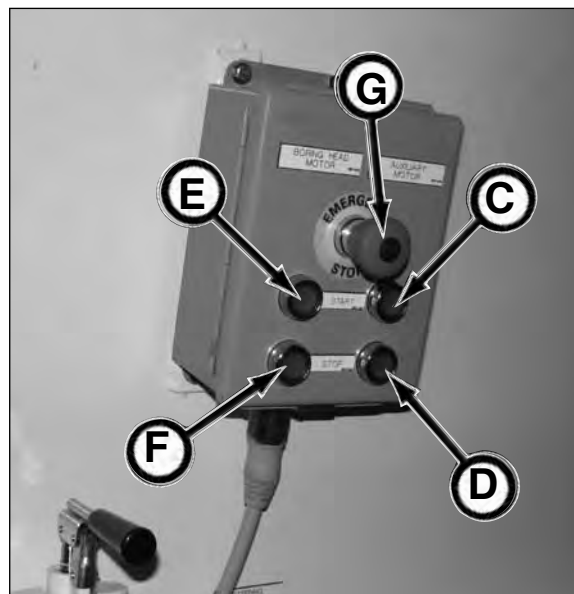

## PIT BOX CONTROLS & INDICATORS

**⚠ DANGER** Hazardous voltage. Disconnect and lock out/tag out power from source before servicing.

**⚠ DANGER** If high voltage cables or cable connections are damaged, contact with cables/connections may result in electrical shock causing severe injury or death. Disconnect and lock out/tag out power from source before servicing.

**⚠ WARNING** Any electrical work completed on the control container or the remote hydraulic power pack must be performed by a certified electrician.

The pit box controls the power from the external power source to the TBM.

The input power from the external power source is monitored for proper three phase electrical power.

With the external power source cable connected to the pit box (refer to section 6, Connecting Power Leads), check for proper phase power. If the green phase (Phase OK) indicator light (A) is illuminated, this indicates that the external power source phase power is installed correctly and that the main power switch (C) can be turned on for the tunnel power circuit.

If the red phase (Phase Error) indicator light (B) is illuminated, disconnect and lock out/tag out ALL power before attempting to reverse two of the generator power leads on the power circuit.

**IMPORTANT: DO NOT start up electric components if the red phase (Phase Error) indicator light is illuminated. Doing so will run components backwards causing damage.**

The Tunnel Power Light (D) will illuminate when power is available for the TBM. The light will illuminate whether or not power is in proper phase, so be sure to check that the green Phase OK light is illuminated before powering TBM.

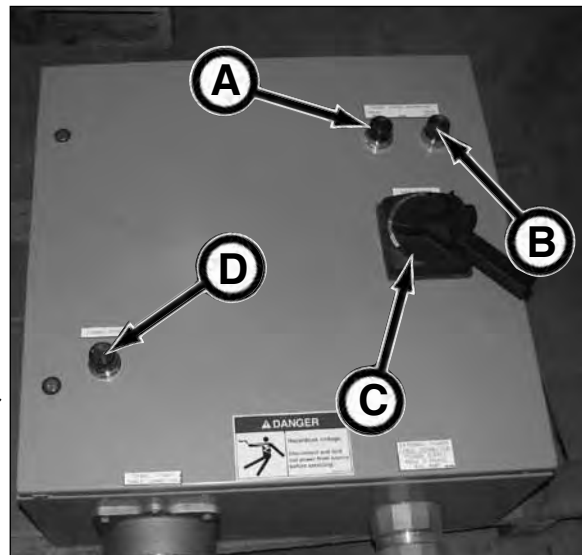

## CLOSED FACE OR AUXILIARY CONTROL

The Closed Face lever (A) controls the opening and closing of the doors on the optional closed face cutter head attachment (B) or other auxiliary hydraulic device. Used in unstable ground conditions, the hydraulically operated doors control subsidence of loose soil while excavating the ground.

A lubrication system (two water/lubrication ports on cutter head) is equipped on the closed face attachment to provide a method to lubricate the face if needed.

Move the control lever as follows:

- PUSH - closes doors (extends cylinders)
- PULL - opens doors (retracts cylinders)

BEFORE operating closed face, extend drum advance cylinders only enough to turn the inner drum without interference with TBM. For more information and operating guidelines, refer to section 6, Using Closed Face or Auxiliary Control.

At the end of each shift change, or at the end of the day, retract drum advance cylinders and close doors to prevent material flow into the TBM. For more information and operating guidelines, refer to section 6, Using Closed Face or Auxiliary Control.

**NOTICE** When using closed face attachment, check wear of inner drum rollers frequently as they will wear unevenly.

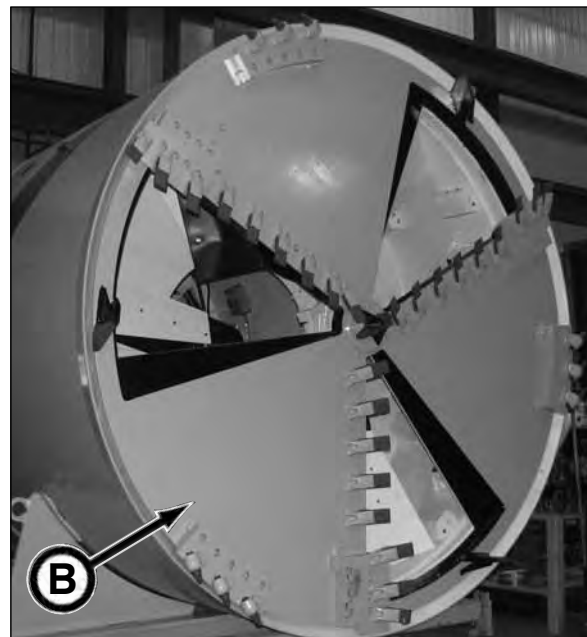
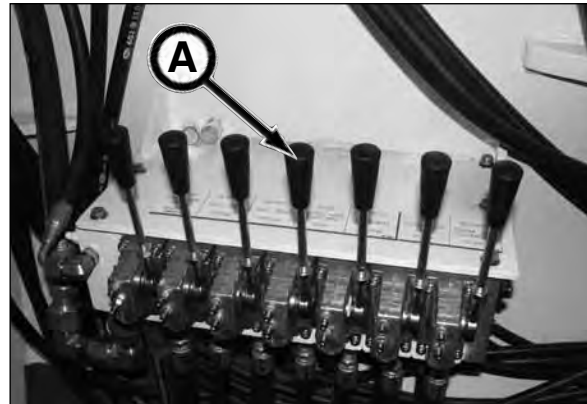

## HYDRAULIC RESERVOIR

The hydraulic system reservoir includes a sight gauge (A), a remote digital temperature display (B) and an empty oil level indicator (C). The reservoir capacity is 75 gal. (284 L).

If the oil level in the reservoir reaches the empty oil level sensor, the empty oil level indicator will illuminate providing the operator a visual warning that the reservoir must be refilled. Also, when the oil reaches the empty oil level sensor, the electrical motors that drive the hydraulic systems automatically shutdown to prevent damage to components. Refill reservoir immediately.

The hydraulic oil temperature should not exceed 125°F (52°C).

To fill hydraulic reservoir, refer to Filling Hydraulic Reservoir in section 6, Operation.

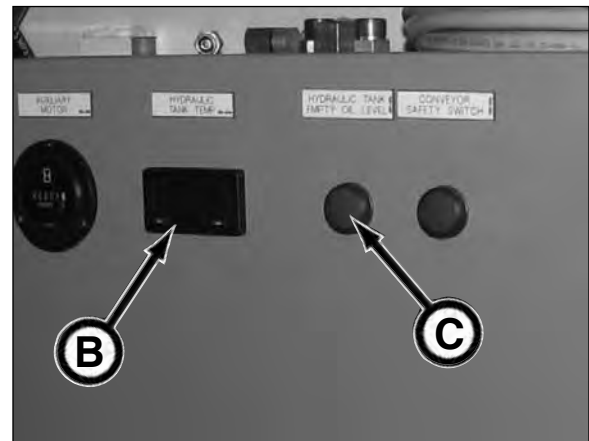
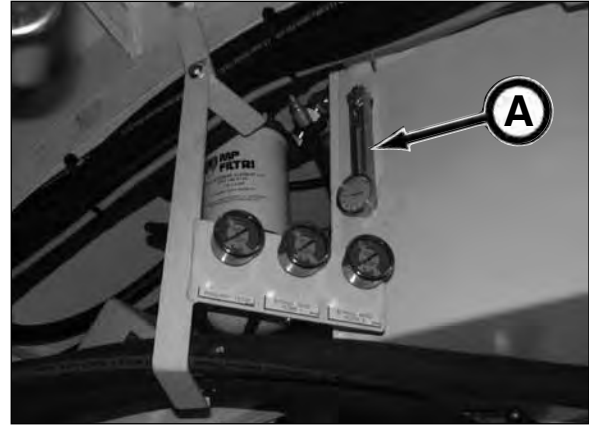

## GEAR RING OILER

Use the gear ring oiler (D) to lubricate the drive gear ring during operation. Be sure gear ring is being lubricated during operation. Failure to do so will cause premature wear/failure to drive gear.

Use the shutoff valve (E) to open and close oil flow from tank.

Adjust gear ring oiler (D) as follows:

- CW - decreases oil flow
- CCW - increase oil flow

Adjust gear ring oiler so the drive gear/rollers are lightly lubricated with oil. Typically a slow drip is sufficient.

Close shutoff valve during pipe change or other pause in tunneling otherwise the drive gear will be over lubricated.

Periodically check gear ring oil tank (F) level. Refill as necessary. Use oil for lubrication. DO NOT USE GREASE!

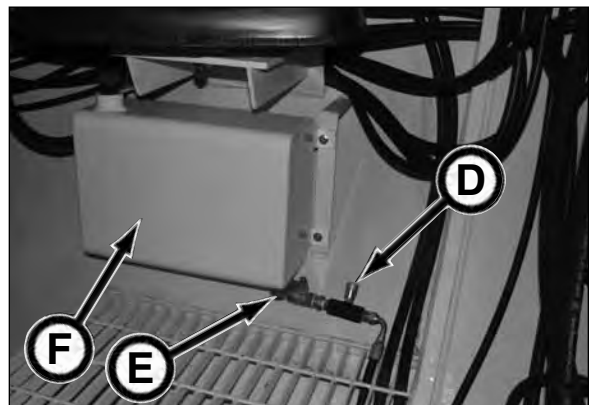

## PRESSURE GAUGES

There are five hydraulic pressure gauges installed on your tunnel boring machine for monitoring the various TBM pressures.

- A - Auxiliary Pressure
- B - Boring Head Pressure - CW
- C - Boring Head Pressure - CCW
- D - Steering Cylinder Pressure - Top
- E - Steering Cylinder Pressure - Bottom

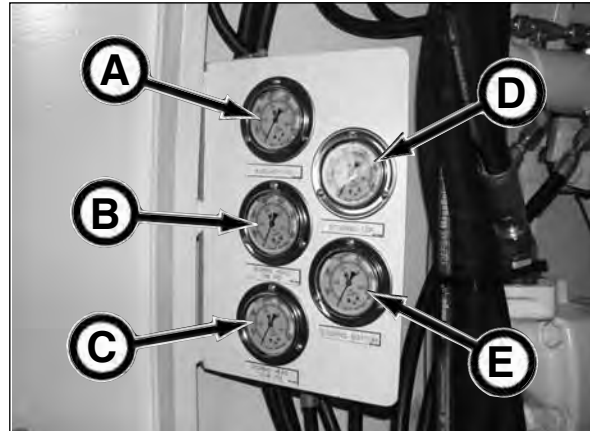

### Auxiliary Pressure (A)

The auxiliary pressure gauge monitors the inlet pressure to the 7 bank control valve. It displays the pressure for the conveyor, conveyor lift, dirt wings, steering cylinder control, and closed face cylinders.

The maximum system pressure is 3,000 psi.

### Boring Head Pressure (B, C))

The boring head pressure gauge monitors the hydraulic rotation pressure from boring head pumps. The maximum boring head rotation pressure is 3,000 psi.

### Steering Cylinder Pressure (D, E)

The maximum steering cylinder pressure to make steering corrections is 3,000 psi. The Steering PSI gauges show the active pressure in the cylinders.

**IMPORTANT: DURING TBM ADVANCEMENT, DO NOT ALLOW STEERING CYLINDER PRESSURES TO EXCEED 3,000 PSI. DOING SO WILL CAUSE STRUCTURAL DAMAGE.**

## HOURMETERS

The 960B is equipped with an individual hourmeter for each motor system. The hourmeter registers in full hours and 1/10th hours.

- Boring Head Motor (F)
- Auxiliary Motor (G)

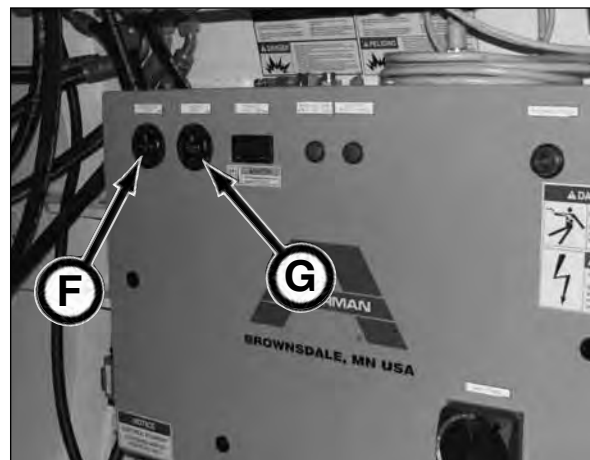

## RETURN FILTER INDICATORS

The auxiliary (A), boring head 1 (B) and boring head 2 (B) return filters on your TBM, filter the oil from the boring head and auxiliary pumps going back into the hydraulic reservoir.

To prevent under or over servicing of the hydraulic filter elements, a filter indicator has been installed for each filter assembly.

The green OK zone indicates that the filter is functioning properly.

The yellow zone indicates that the filter will soon require replacement.

Replace filter when the indicator needle on the gauge is in the red CHANGE zone.

### NOTICE

The indicator needle may display in the red CHANGE zone at initial start-up until the oil reaches normal operating temperature. If the indicator needle continues to display in the red CHANGE zone after reaching normal operating temperature, replace filter to prevent contamination.

Return Filter Indicators:

- Auxiliary Return Filter Indicator (D)
- Boring Head 1 Return Filter Indicator (E)
- Boring Head 2 Return Filter Indicator (F)

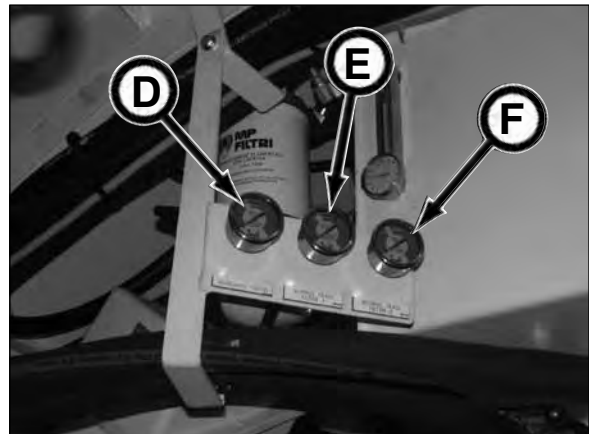
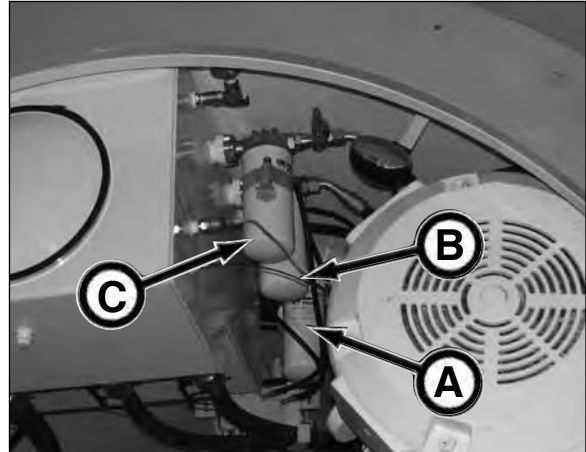

# Pre-Start Inspection

## **⚠ WARNING**

Do not operate this equipment until you read, study, and understand this manual and your haul unit, gas detection system, jacking frame, and power unit operation manuals. A daily inspection of the equipment must be performed to prevent severe personal injury or death and equipment damage.

The contractor is fully responsible for the safety of all personnel on the job site. Check with the contractor that all site preparation requirements are in place. Be sure to comply with all OSHA regulations, such as: an active safety program is in practice, a confined space permit is issued, personal protective equipment is being worn; flammable, combustible, and hazardous materials are properly stored; and a lockout/tagout procedure is in place.

Use the following checklist ✓ as a guide for your daily pre-start inspection.

	1. Use "ONE-CALL" notification to check for buried utility lines prior to tunneling.
	2. Check the excavated launch and reception shafts for proper shoring or bracing to prevent slides or cave-ins.
	3. Thoroughly clean equipment of mud and dirt. Keep job site clean and organized.
	4. Check condition of personal protective equipment. Replace equipment if defective.
	5. Contractor is responsible for all personnel to wear proper protective equipment on the job site.
	6. Remove combustible or flammable materials from equipment. Store materials properly.
	7. Test all Emergency Stop buttons on TBM and supporting equipment for proper operation at the start of each shift.
	8. Test air monitoring and ventilation detectors for proper operation.
	9. The gas detector sensor must be installed with the sensor facing down to ensure proper operation and to prevent the buildup of moisture or contaminants, such as oil and dirt.
	10. Thoroughly inspect all equipment for damage, including loose or missing hardware. Repair or replace before operating.
	11. Be sure all covers and guards are in place before operation.
	12. Check electrical lines for frayed, damaged, or worn insulation or wires. Replace damaged or worn electrical lines/connections.
	13. Check for fluid leaks. Repair leak or replace components.
	14. BEFORE starting, the phase power MUST be installed correctly. Otherwise damage will occur to components.
	15. Perform all lubrication and maintenance procedures. Refer to Section 9, Periodic Maintenance.
	16. Test each function and control to ensure correct operation.
	17. Check hydraulic hoses and lines for leaks, wear and/or damage. Replace any defective hoses and/or lines.
	18. Check oil level in hydraulic reservoir. Add as needed.
	19. Perform pre-start inspection on your equipment. Refer to your equipment's operator's manual.
	20. Conveyor MUST be secured with four safety chains to conveyor bracket in TBM, and chain from conveyor safety switch must be tethered to conveyor.
	21. Test the electrical motors for proper rotation prior to operation.
	22. Decals must be clean and legible.

## **NOTES**

# Operation

## OPERATING GUIDELINES

**⚠ WARNING** Do not operate this equipment until you read, study, and understand this manual and your haul unit, gas detection system, jacking frame, and power unit operation manuals. Failure to do so, could result in severe personal injury or death.

1. Before operating, read and understand the Safety, Pre-Start Inspection, Operation and Maintenance sections.
2. Do not operate this equipment while under the influence of alcohol, drugs, or medication.
3. Follow all Federal, State, and Local safety regulations and procedures.
4. Be sure OSHA prescribed safety protective equipment is being worn by all personnel.
5. Be sure the area is safe for operation. Keep worksite clean and orderly.
6. NEVER operate equipment if it has been engulfed with water. Contact your Akkerman Aftermarket Support representative for proper procedures on how to restore equipment for operation.
7. Have a fully charged fire extinguisher on the job site at all times.
8. Once survey is complete, perform a general visual inspection of the survey line to make sure it is in the same direction as the project bore. If not, the survey must be remarked. A good survey is critical for proper line and grade.
9. Before operating, thoroughly inspect all equipment and repair equipment problems. Check hoses for cuts or bulges. Replace worn or damaged hoses.
10. Be sure the excavated launch and reception shafts are properly shored or braced to prevent slides or cave-ins.
11. Test air monitoring and ventilation detectors for proper operation. Never enter a tunnel without air monitoring and ventilation detectors, such as combustible gas detectors and oxygen deficient detectors.
12. Fresh air must be supplied to all underground work areas in sufficient amounts to prevent any dangerous or harmful accumulation of dusts, fumes, mists, vapor or gases.
13. A fully trained and qualified signal person must direct the excavator or crane operator when lifting and lowering equipment, pipe and supplies into the launch or reception shafts.
14. Never walk or work under any part of the excavator or crane and suspended loads.
15. Test each function and control to make sure they work properly.
16. Lock out electrical power at the source (generator) before servicing electrical components.
17. Do not make any modifications to any Akkerman products. Doing so could cause structural failure and will void the warranty.
18. Check shields and guards. All must be in place and undamaged.
19. Before starting equipment, thoroughly inspect all equipment. Inform all job site personnel that the equipment will be starting up. Do not start until all unauthorized personnel are clear of the equipment.

*(continued on next page)*

**Operating Guidelines (continued)**

20. After start-up, observe all gauges, meters, controls and warning devices to assure they are functioning properly and their readings are within the operating range.
21. Never leave the operator's station without first releasing hydraulic pressure, performing daily system shutdown, and disconnecting the main power supply.
22. Lockout/tagout the main disconnect, shut off generator or other external power source, and attach a DO NOT OPERATE tag or similar warning tag to the main power disconnect before performing maintenance.
23. Check line and grade alignment often. Keep in mind if you are off one degree, the bore will be off nearly two feet per one hundred feet.
24. Keep hands, body, and objects clear of rotating conveyor or operating auger. Do not operate without covers and guards in place. Lockout power before servicing.
25. If this manual becomes lost, contact your Akkerman Aftermarket Support representative for a new manual or download this manual from the Akkerman web site at [www.akkerman.com](http://www.akkerman.com).
26. The operator must note and report any slow down of machine operating time that might be an early warning of future problems.
27. Do not make adjustments or repairs to any of the system components while in operation. All pressure must be released and electrical power must be in lock out, tag out before adjustments or repairs.
28. High pressure hydraulics are used on the jacking system. Be sure all cover and guards are in place before operating.
29. Check laser beam often to avoid mis-alignment. Keep boring head well ventilated to achieve a consistent temperature throughout the pipeline since changes in temperature inside the pipe can cause laser beam to stray off target.
30. BEFORE operating conveyor, the chain from the conveyor safety switch MUST be tethered to conveyor AND ALL FOUR safety chains MUST be secured to conveyor.
31. Conveyor must not be started until all personnel have been moved away from the conveyor and have been warned that the conveyor is about to start up.
32. Before operating conveyor, all guards and/or safety devices must be in place and operable to prevent any contact with conveyor.
33. The area around conveyor loading and unloading points must be kept clear of obstructions during conveyor operation.
34. Conveyor must be stopped and the power source in lockout/tagout before performing maintenance, repair, or servicing.
35. The conveyor must be in placed in lockout/tagout before attempting to remove a jam or overload.
36. Wear reasonably close fitting clothing and remove jewelry to prevent an entanglement hazard.
37. While cutterhead and conveyor are operating, the operator must remain seated in normal operating position.
38. During TBM advancement, do not allow steering cylinder pressures to exceed 3,000 psi. Doing so will cause hydraulic component & structural damage.

## SYSTEM OVERVIEW

### ***Tunnel Boring Machine (TBM)***

The purpose of the TBM is to excavate material at the cutter face and guide (steer) the pipe through the ground. As the TBM is advanced by the pipe jacking system, powerful hydraulic motors in the TBM rotate an inner drum. A cutter head or closed face attachment is connected to the drum. As it rotates, the attachment teeth excavate the face and the spoils fall into the drum. Dirt scoops and paddles in the drum dump the spoils onto a conveyor for removal from the pipe line.



Akkerman TBMs are articulated and hydraulically steerable in any direction. With the proper use of a laser, the strictest line and grade requirements can be maintained throughout the pipeline installation. An operator is positioned near the front of the machine to observe soil conditions and to monitor line and grade. A methane detection system is also standard equipment in Akkerman boring machines.

### ***Pipe Jacking System***

The pipe jacking system (5000 Pump Unit with thrust yoke or jacking frame) provides the horizontal thrust, using hydraulic cylinders, to push the TBM and pipe through the ground.

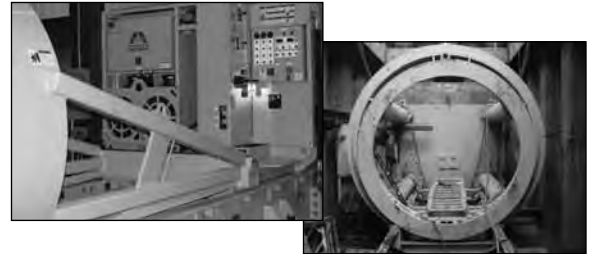

### ***Conveyor***

As the spoils are dropped onto the conveyor from the TBM inner drum, the conveyor carries the material to the dirt bucket on the haul unit. The conveyor transports the spoil from the front of the boring head to the dirt bucket on the haul unit. Conveyors are offered in several sizes to maximize the performance for each size boring head. A screw conveyor performs better in certain sticky or sloppy ground conditions.



### ***Haul Unit System***

The haul unit transports the spoils from the tunnel boring machine back to the launch shaft. A crane is then used to hoist the dirt bucket out of the shaft for unloading. The typical haul unit system is comprised of a haul unit, track, and dirt bucket.

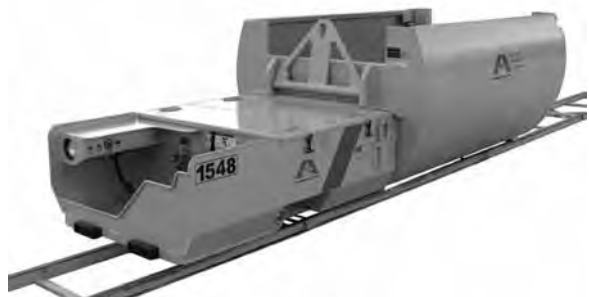

## CUTTER HEAD ATTACHMENTS

**Dirt Head**

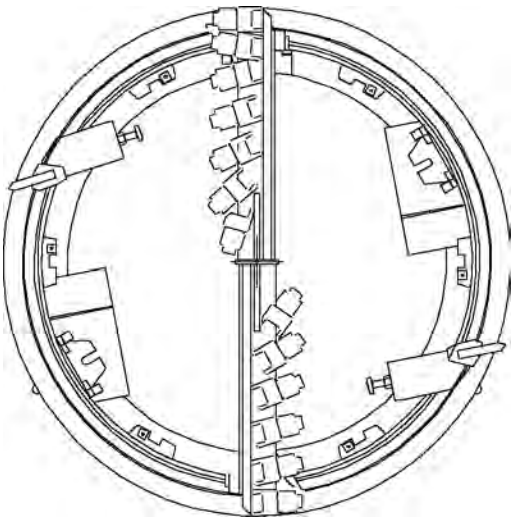

**Quad Carbide Bar Head**

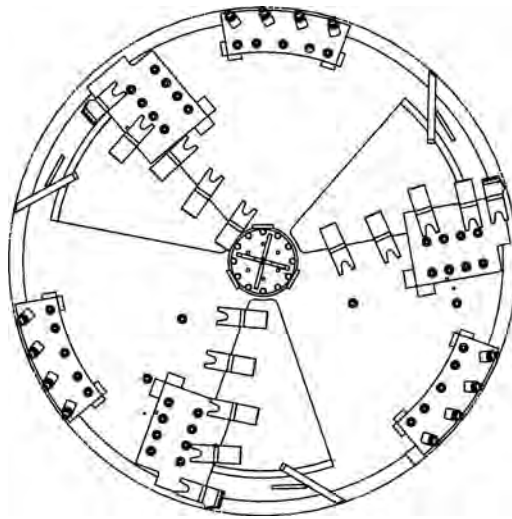
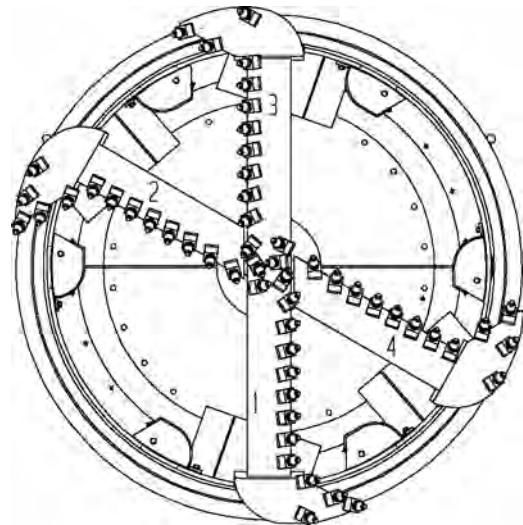

**Closed Face**

The 960B Tunnel Boring Machine is equipped with two cutter heads and may be interchanged underground.

- Dirt Cutter Head (clay, silty sand, etc.)
- Carbide Cutter Head (soft to medium hard rock)

A Closed Face Cutter Head is available and is used for boring in unstable ground conditions. The hydraulically operated doors control subsidence of loose soil while excavating the ground.

## RECOMMENDED TOOLS & EQUIPMENT

Below is a list of tools and equipment for most complex technical construction operations. Financial resources and equipment availability are as much of a deciding factor as immediate job site requirements in determining what items should be on hand. This list contains many items, some of which may only be needed in special situations.

1. Safety equipment, first-aid kit, fire extinguishers, and stokes-type stretcher.
2. Any other required safety gear, such as air monitoring and gas detection systems, including personal gas detectors.
3. Ventilation fan(s) and ducting.
4. Communications equipment and good quality flashlights.
5. Generator sized for the project's power requirements including an adequate fuel supply for the generator's minimum period of operation.
6. A crane sized to project requirements.
7. Adequate pumping capacity for launch and reception shaft sump, and process water overflow, potential storm event inflow, trash pump, and hoses.
8. Adequate job site lighting, crew safety vests, and traffic control devices/signage, and barricades.
9. Wash down hose and spray nozzle.
10. Measuring and surveying equipment; including sight level or theodolite, laser levels, plumb-bobs, string lines and 100' tape measure.
11. Secure tool and equipment storage.
12. Rubber-tired front-end loader with bucket and forks.
13. Skid steer loader.
14. Shovels, rakes, and brooms.
15. Bullfloat and trowels.
16. Concrete bucket, tremie hose and hopper.
17. Carpentry tools including circular saw, sawzall, extension cords, and cordless drill w/bits, and basic hand tools.
18. Hammer drill and masonry bits, small "rivet buster" type jackhammer, chisels.
19. Sledgehammer(s), pry and crowbars of all sizes, spud wrenches, and pick-bars.
20. Various sizes hydraulic bottle jack(s), railroad or house type jacks, portapower hydraulic jack cylinder kit.
21. Log chains, shackles and clevis'.
22. Chain or cable-type "come alongs."
23. Arc welder and cutting torch rigs, eye shields and required protective gear.
24. Disc and mini-disc grinders, and extra discs.
25. Mechanic's tools, including but not limited to; wrenches, sockets, allen wrenches, torque wrenches, pliers, screwdrivers, hammers, etc.
26. Grease gun.
27. Electrician's tools, including test meters, voltage indicator, ground fault indicator, and specialty hand tools.
28. Pipe wrenches, water pump pliers, pump packing removal kit.

## SITE PLANNING

It is important to carefully review the site and make sure that it is arranged in the most effective manner possible. Here is a list of equipment and site considerations that are typically needed for a TBM project.

### *Equipment:*

- |                             |                    |                         |
|-----------------------------|--------------------|-------------------------|
| - TBM                       | - Crane            | - Pipe Lubrication Pump |
| - Pipe Jacking System       | - Portable Welders | - Spoil Removal Truck   |
| - Skid and Jacking Frame    | - Small Generator  | - Portable Toilet       |
| - Generator Or Power Source | - Fork Lift        |                         |

### *Other site considerations:*

- |  |                         |                               |
|--|-------------------------|-------------------------------|
| - Spoil Removal Truck Access               | - Pipe Unloading area   | - Fresh Water Supply          |
| - Launch Shaft Size                        | - Hose Interconnections | - Electrical Interconnections |
| - Walkways                                 | - Pipe Staging Area     | - Jacking Shaft Access Area   |
| - Any Traffic or Other Physical Restraints |                         |                               |

## SITE PREPARATION

1. The contractor is fully responsible for the design and construction of the OSHA required launch and reception shafts. For setup and installation drawings specific to the project, pipe size and shoring type, contact the Akkerman Sales Department.

**⚠ WARNING** Gases may be present during excavation and could cause severe personal injury or death. Use an approved air analyzer to detect hazardous gases on the job site and in the tunnel at all times.

2. After the soil analysis, shaft layout design, and survey are complete, excavate the launch and reception shafts. Be sure the shafts will be well drained and use proper shoring or bracing in accordance with your local, state, and federal regulations.

3. Construct a shaft floor with a solid base suitable for the weight of the skid, yoke, pump unit, jacking frame, TBM system and pipe. Consult your civil and structural engineers for your shaft floor requirements.

4. Place steel plates on the jacking shaft floor for supporting the base of the skid (rails), jacking frame, TBM, and pipe.

5. Construct a concrete thrust block designed to withstand the applied load. A structural engineer must be consulted on the design of this block. This block must be square with the line of the tunnel axis and jacking frame assembly.

**NOTICE** If using a jacking frame, space must be provided for the mounting of the laser behind the jacking frame.

6. Proceed to System Set-Up in this section.

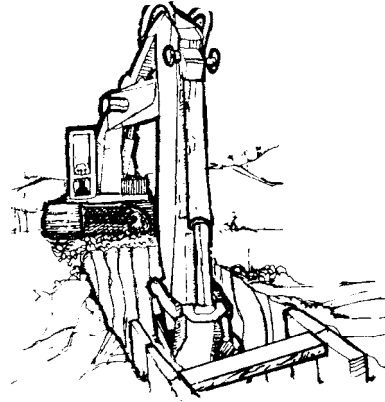

*AEM is the original author and publisher of the above illustration*



## SYSTEM SET-UP

**⚠ WARNING** Suspended loads may fall and cause severe injury or death. Do not allow anyone to enter area under or around a suspended load.

**NOTICE** Be sure the crane or excavator and all lifting equipment is rated to lift load. Remember, you may be able to lift the load in close at ground level, but as the load radius and elevation change, the lifting capacity of the crane or excavator or other lifting equipment decreases.



1. Lower skid assembly into launch shaft using lift eye assemblies (A) and place against the thrust block. Correct the skid assembly line and grade with leveling screws (see inset). Typically there should be at least 6 inches between the front of the jacking rails and the shaft wall to allow room for the cutterhead of the TBM.

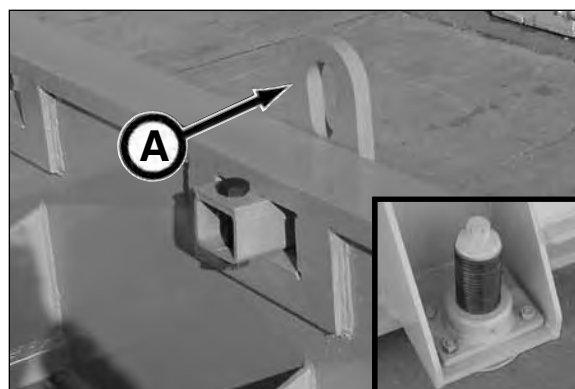

If necessary, lower other skid assembly(s) into launch shaft and mount to first skid assembly as follows:

- a. Align the skid sections using the locator pin (B).

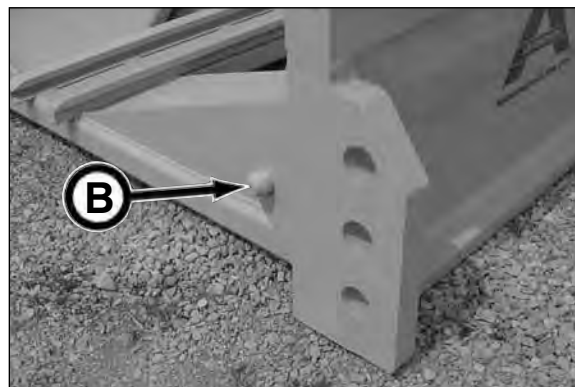

- b. When skid assemblies are properly aligned, mount with six 2 in. bolts and nuts.



(continued on next page)

- c. To complete mounting, install skid split bars (A) into side skid base assembly making sure the holes of the bar line up with the holes (B) in the skid assembly. Insert skid split pins (C) with slot of pin at the 12 o'clock position for set screw. Secure skid split pin with set screws (D).
- d. Continue mounting other skid sections, if required.

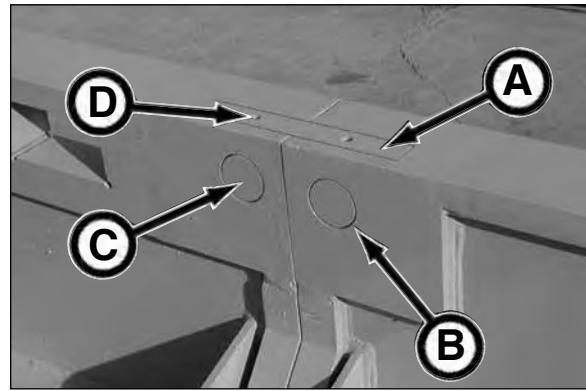

- e. Check to be sure that the skid assembly is making full contact against thrust block.

**NOTICE**

Both the left and right ends of the skid frame **MUST** be against thrust block, otherwise damage will occur to the skid frame during jacking operation.

- f. Once skid assemblies are properly joined, check for the proper line of the project bore. Adjust skid (s) as needed.
- g. Once skid assemblies are in the proper line, correct the skid assembly grade with leveling screws (E). Due to the weight of the skid assemblies, place a hydraulic jack below the jack pad (F) to raise or lower skid as needed for ease of adjusting grade with leveling screws.
- h. When completed, recheck line and grade and adjust as needed.

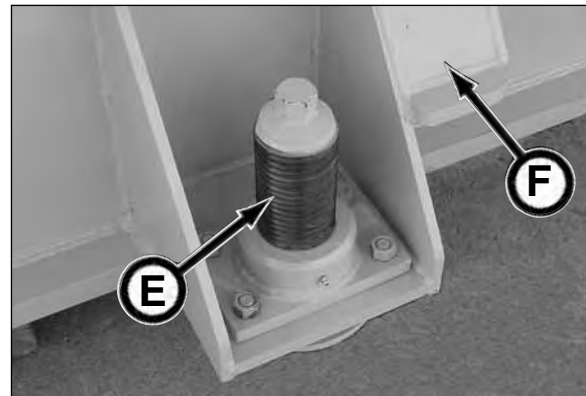

- 2. (Pump Unit, if used) Lower the pump unit onto skid assembly. Check to be sure the drive wheels are resting on the skid assembly top rails.

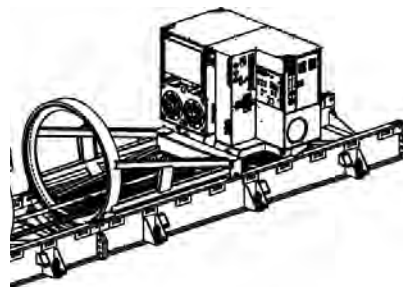

(continued on next page)

3. (Yoke, if used) Lower the yoke (in front of the pump unit) onto the lower skid assembly rails (A) , while making sure the yoke wheels are resting on the top skid assembly rails (B).

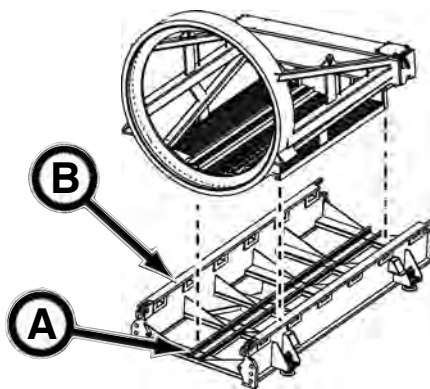

4. (If equipped with jacking frame) Recheck line and grade of skid assembly rails. Lower jacking frame onto skid assembly rails and make sure the frame is properly centered on the rails.

Lower power pack on a level, solid foundation an appropriate distance from the edge of the shaft to prevent shaft cave-in.

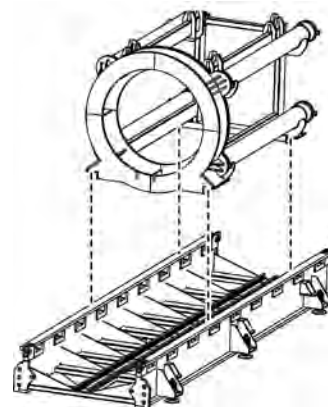

**WARNING** Tunnel boring machine is top heavy.

Any unintended movement may cause TBM to roll, resulting in serious injury or death upon contact.

Use EXTREME caution while handling TBM to prevent rolling.

**WARNING** Contact with rolling tunnel boring machine can cause serious injury or death.

ALWAYS use cradles to secure TBM from rolling during transport.

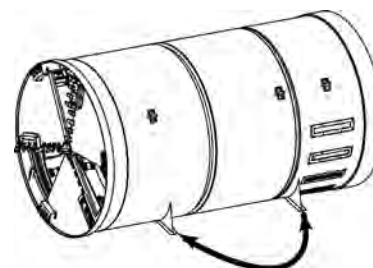
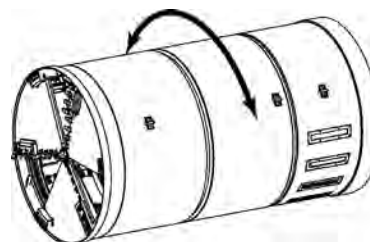

5. Lower tunnel boring machine (TBM) onto the front of the skid assembly. Be sure the cutter teeth on the TBM will not strike the skid assembly when the cutterhead is rotated.

**NOTICE** Remove cradle supports from TBM before placing TBM on skid assembly. Handle TBM carefully since it is top heavy.

(continued on next page)



6. Check TBM side to side level by placing level on the cylinder lift trolley rail (A). If not level, have crane operator move the TBM until TBM side to side is level.

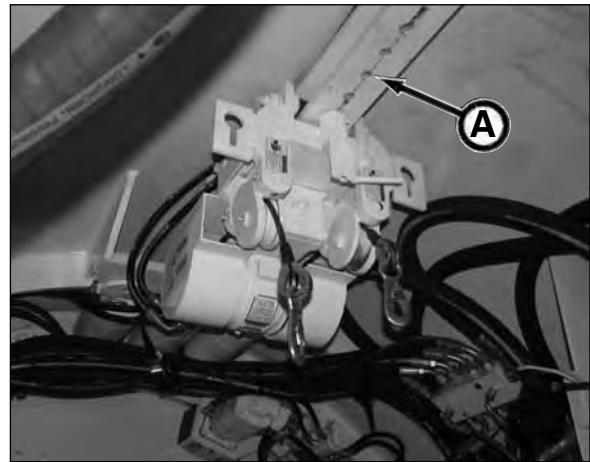

7. Place level on inner drum level bar (B) and rotate the inner drum as needed until level. This will position the target bolt (C) on the cutter bar in the proper location for setting the guidance system.



8. Check to be sure front drum is parallel with mid drum/dirt wing drum. Place a 4' level or other long straight edge between the front drum and mid drum sections (as shown). If mid section lines up with level or straight edge, then the front and back sections of the TBM are running parallel.

If there is a gap between the two sections, the sections are not parallel. Move steering cylinders or if needed, move the steering adjustment nut until there is no longer a gap.

**NOTICE**

The TBM line and grade **MUST** be steered parallel to the jacking system base.

9. Recheck jacking system base grade and alignment. Check machine elevation and make final pipe line calculations, allowing for cutter bit "over cut."

*(continued on next page)*



**⚠ DANGER** Staring into laser light will cause severe injury.

Do not stare into laser guidance system light beam. Avoid direct eye exposure.

To avoid possible exposure to radiation in excess of acceptable emission limits, all repairs to laser must be performed by the original manufacturer or an authorized service technician.

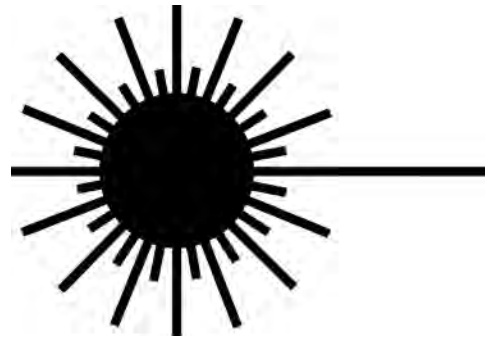

10. Lower the stand for the laser guidance system as close to the rear of the jacking shaft as possible without contacting skid assembly, jacking frame, pump unit or thrust block. Be sure the guidance system will not be affected by thrust applied to jacking system.



**NOTICE** For proper guidance system installation, refer to your laser manufacturer's installation requirements. Be sure laser beam has a clear path to target.

11. Place the generator or main power source as far away from the launch shaft as possible. This will reduce the noise to the operator and make it easier to communicate with the launch and reception shaft personnel.
12. (If required) Install the launch shaft seal and casing in the front of the launch shaft.
13. Recheck the jacking system base frame and alignment. Check machine elevation and make final pipe line calculations allowing for the cutter bit "over-cut." The TBM alignment and grade must be steered parallel to the jacking system base.



**⚠ WARNING** NEVER operate tunneling equipment without proper operating gas detection systems. Severe personal injury or death can occur without proper gas detection systems in place due to accumulation of combustible and toxic gases, and depletion of oxygen.

If the gas levels exceed MSHA/OSHA prescribed levels, leave tunnel immediately! Do not activate or deactivate any electrical or hydraulic devices, since any sparks could cause an explosion.

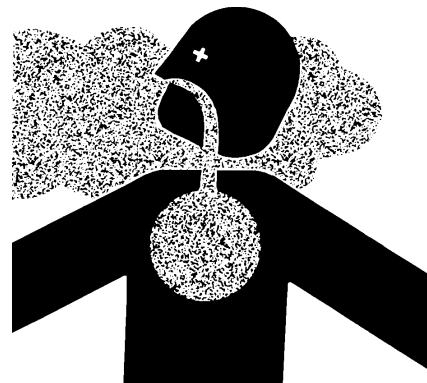

*(continued on next page)*

14. With power source in lock out tag out, connect electrical 480V power cable from generator or power source to the pit box connection (refer to Connecting Electrical Supply To Pit Box in this section).

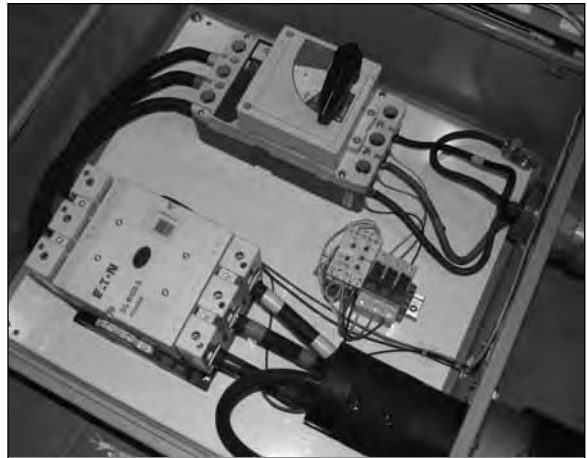

15. Install 480V power cable (A) (supplied) from pit box to power connection (B) in TBM (refer to Connecting Electrical Supply To Pit Box & TBM in this section).

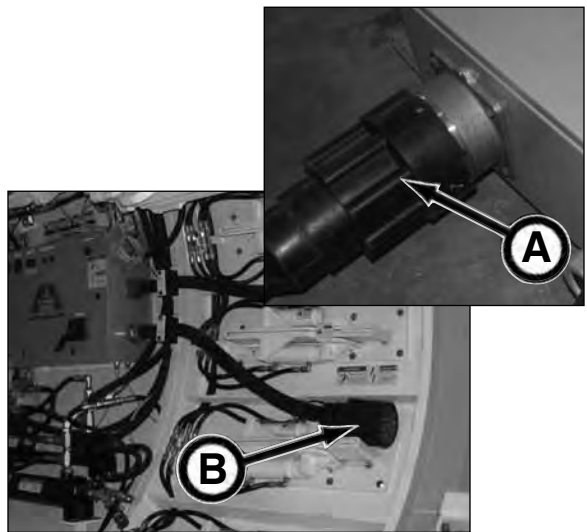

16. Connect the pump unit/jacking frame hydraulics and electrical connections (refer to your pump unit/power pack/jacking frame operation manual). The 5000 Pump Unit hydraulics will be used only for the thrust cylinders. The 960B is equipped with an on-board power pack to provide the hydraulics for the TBM functions.



(continued on next page)

**⚠ WARNING** PINCH POINTS! Watch your fingers, hands, and legs while equipment is in operation.



**⚠ WARNING** Conveyor is heavy and could drop while installing or operating, resulting in severe personal injury or death. Conveyor must be fastened securely to supports while moving conveyor into position. Once conveyor is in position, lifting cables and ALL FOUR conveyor safety chains MUST be secured to conveyor.



17. Carefully install conveyor into the TBM and connect the lifting cables to the front lifting position on the conveyor lifting eyes.
18. Lift the conveyor with the conveyor lift and slip bearing at the front of the conveyor onto the pin at the center of the cutter bar.



*(continued on next page)*

19. Connect the four safety chains to the conveyor and lower the conveyor lift just enough to provide adequate slack in the lift cables to move the lifting hooks to the rear (operating) position on the conveyor lifting eye.

**⚠ WARNING**

Conveyor can jam in rotating cutterhead causing conveyor to swing into operator, resulting in severe personal injury.

1. The conveyor safety valve MUST be tethered to conveyor and the operation MUST be tested before starting the conveyor to insure proper operation.
  2. ALL FOUR safety chains MUST be secured to conveyor.
  3. Operator MUST remain seated in normal operating position.
20. Fasten chain (A) from conveyor safety switch (B) to conveyor hook (C).

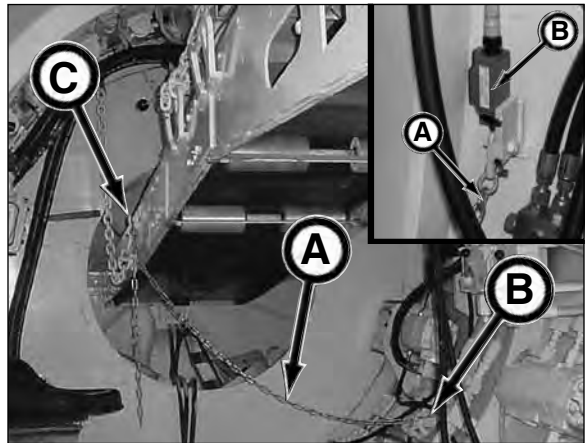

21. Connect conveyor supply and return hydraulic hoses to TBM quick disconnects (D).
22. Proceed to Connecting Power Source To Pit Box & TBM in this section.

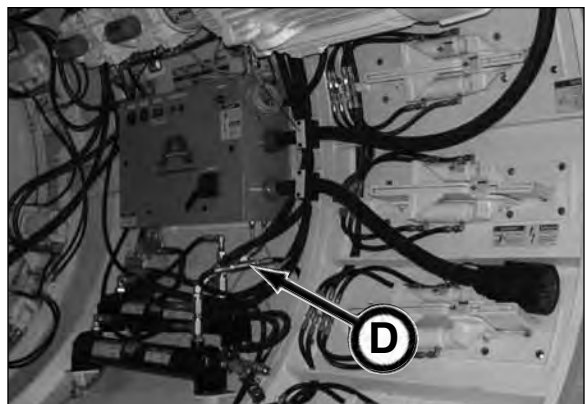

## CONNECTING POWER SOURCE TO PIT BOX & TBM

**⚠ DANGER** Hazardous voltage. Disconnect and lockout/tagout power from source before servicing.

**⚠ WARNING** Any electrical work complete on the 960B must be performed by a certified electrician.



1. Lockout/tagout power source.
2. Open pit box cover.
3. Route 480V, 3 Phase, 400 AMP power cable with ground through strain relief (A).

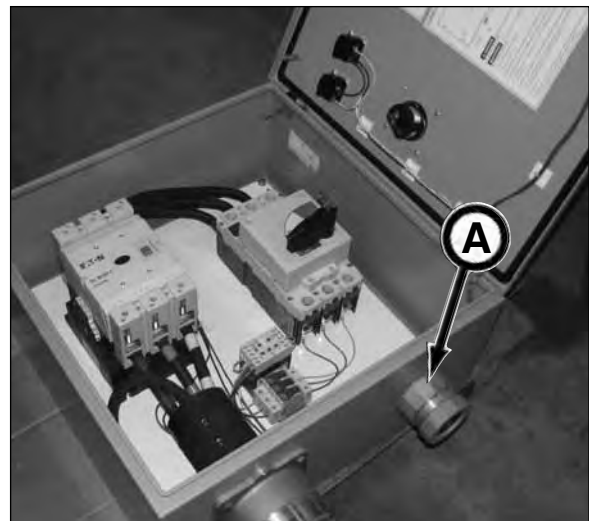

4. Connect (green) ground cable lead to pit box ground lug (B).
5. Install Brown (C), Orange (D) and Yellow (E) cable leads to 400 AMP breaker terminals (F).
6. Secure cable leads to breaker terminals using an allen head socket wrench.
7. Secure power cable to pit box by tightening nut (G) on strain relief. Pull on cable to ensure cable is securely mounted to strain relief.
8. Close cover.

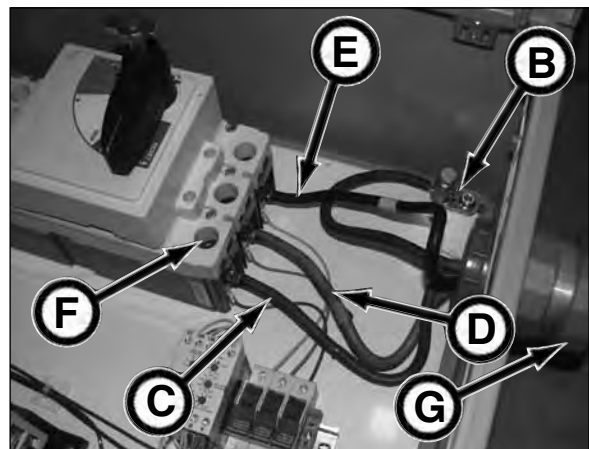

*(Continued on next page)*

9. Check for proper power phase as follows:

- With the 480V, 3 Phase, 400 AMP power cable properly installed to the pit box, push in E-Stop buttons, place pit box main power switch (A) in OFF position and power up the main power source.

- Check the power phase indicators on the pit box:

The input power is in proper phase if the green Phase OK indicator (B) is illuminated.

If the red Phase Error indicator (C) is illuminated, the input power is not in proper phase. Therefore, a certified electrician must lockout/tagout power source and reverse the two generator power leads.

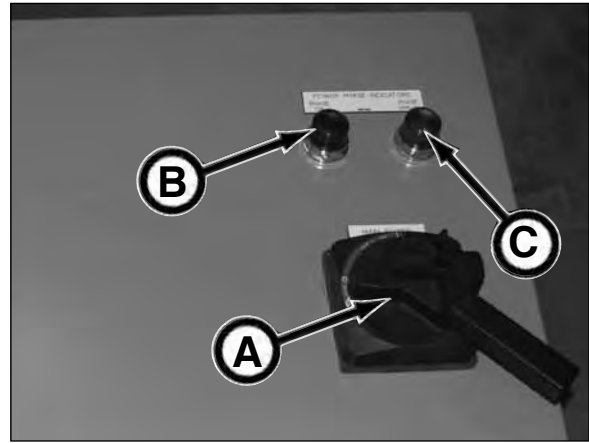

**IMPORTANT: DO NOT** start up electric components if the red Power Phase Error light is illuminated. Doing so will run components backwards causing damage.

10. Install the 480V power cable from the pit box to the Incoming Power connection (D) from the TBM electrical box.

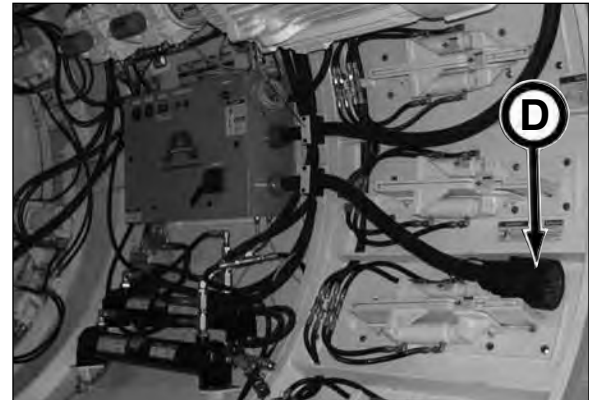

11. Be sure the cable (E) from the E-Stop/Boring Head Motor/Auxiliary Motor control is connected to the electrical box.

12. Pull out E-Stop buttons.

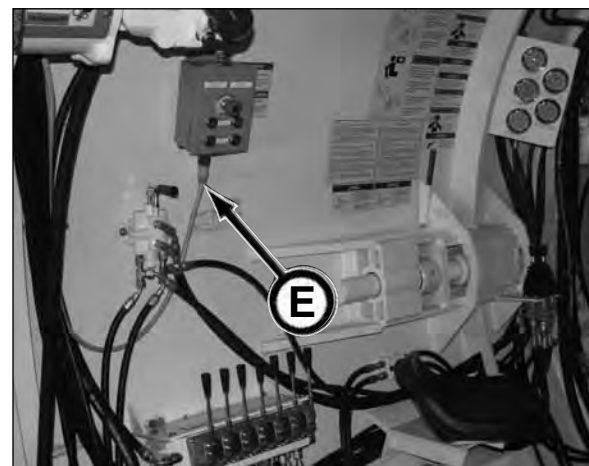

13. Turn on power source, turn on pit box main power switch (A) and check to be sure Tunnel Power light (B) on the Pit Box and Incoming Power light (C) on the TBM electrical box are illuminated. If lights are not illuminated, lockout/tagout power source and check to be sure power cables are properly connected. Recheck power.
14. Turn TBM main power switch (D) to the ON position to power the TBM (E-Stop buttons must be pulled out). The 480V power provides power to the 200 HP boring head motor and the 50 HP auxiliary motor. The 480V circuit also powers a transformer inside the electrical box which converts the 480V power to 24 VDC. The 24 VDC circuit provides power for the lights, gas detector empty level sensor, temperature sensor and the conveyor safety switch circuit.
15. Proceed to Checkout Equipment Prior To Start-Up in this section.

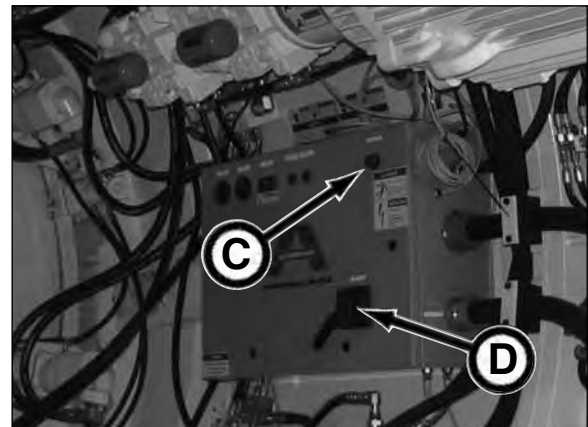
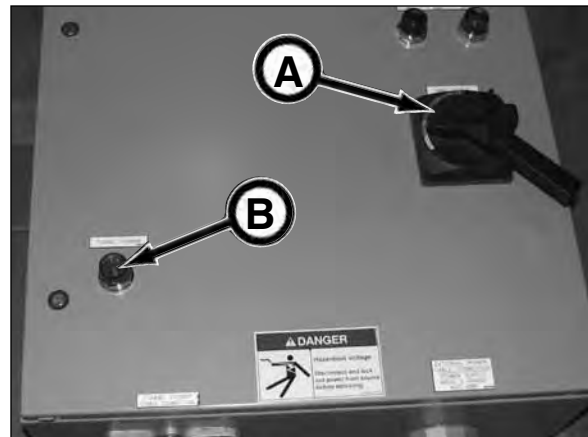

## CHECKOUT EQUIPMENT PRIOR TO START-UP

1. Perform equipment (including other supporting equipment such as 5000 Pump Unit or jacking system) maintenance as shown in Periodic Maintenance section.
2. Connect clean water supply hoses with 20 GPM minimum to oil coolers in TBM and heat exchanger in pump unit.

**NOTICE** If pumping 85+°F water, flow should be around 25 GPM.

3. Check the oil level in the TBM hydraulic reservoir and the pump unit hydraulic reservoir. Add oil if necessary.
4. Inspect conveyor lift cables daily and replace immediately at the first sign of wear or damage.
5. Check to be sure all suction valves are open and tie strapped to prevent accidental closing of valves.
6. Inspect all hoses and electrical lines for damage. Replace before operating.
7. Be sure all hydraulic hoses and electrical lines are properly installed.
8. Refer to your haul unit, gas detection system, pump unit, and jacking frame operation manuals for pre-start checks.
9. Be sure to check the operation of ALL E-Stop buttons before operating TBM.



## USING EMERGENCY STOP

**WARNING** ALL Emergency Stop buttons MUST be operating properly BEFORE operating TBM, Pump Unit and TBM. Failure to do so may cause severe injury or death.

### ***E-Stop on 960B TBM***

Push 960B Emergency Stop button (A) IN to stop all electrical and hydraulic power in the TBM.



*E-Stop on 960B TBM*

### ***E-Stop on Supporting Equipment***

For E-Stop operation on any supporting equipment, refer to the operation manual of the equipment.

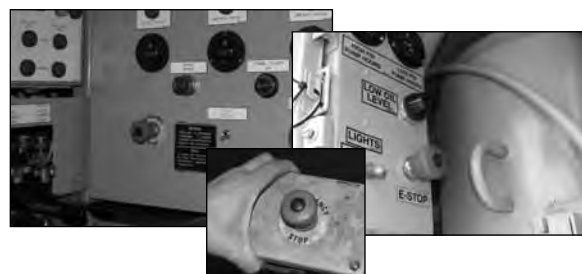

## TBM START-UP PROCEDURE

1. The 5000 Pump Unit/jacking frame start-up check must be performed prior to TBM start-up. Refer to 5000 Pump Unit operation manual for details

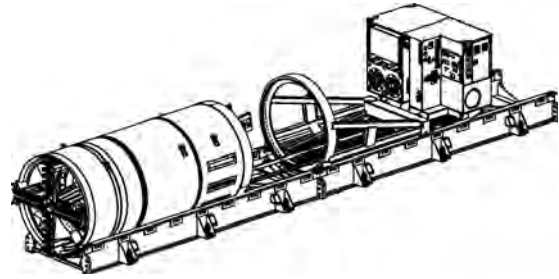

2. With power in lockout/tagout, connect the power source power cables to pit box and TBM. Refer to Connecting Power Source To Pit Box & TBM in this section. Be sure input power is in the proper phase.
3. Move pit box main power disconnect (A) and the TBM electrical box main power disconnect (B) to the OFF position.

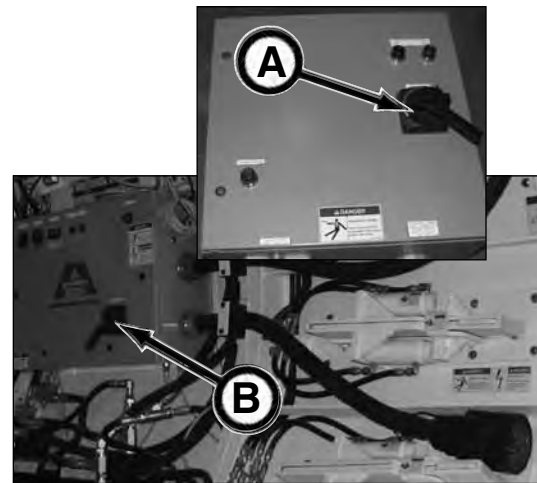

4. Move all TBM, pump unit/jacking frame control valve handles to the neutral or OFF position.



5. Turn on external power source. Check input power phase by making sure Phase OK light (C) is illuminated on pit box.



*(continued on next page)*

6. Pull out E-Stop (A) on TBM motor control and pump unit/jacking frame.

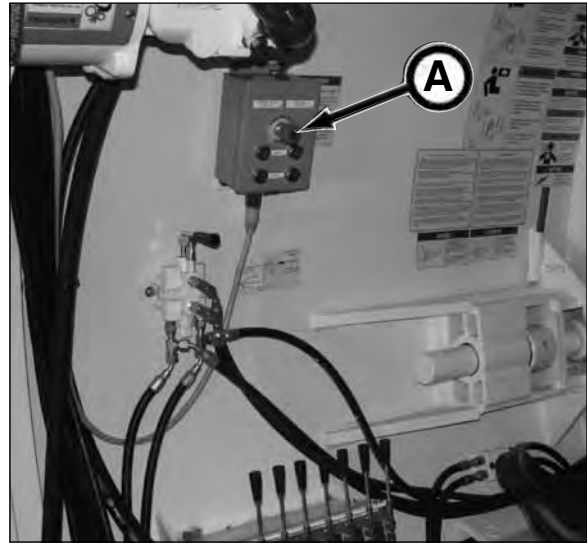

7. Move pit box main disconnect (B) to the ON position.

8. Check to be sure the pit box tunnel power light (C) and the TBM electrical box Incoming Power light (D) are illuminated. If lights are not illuminated, a certified electrician must troubleshoot the problem.

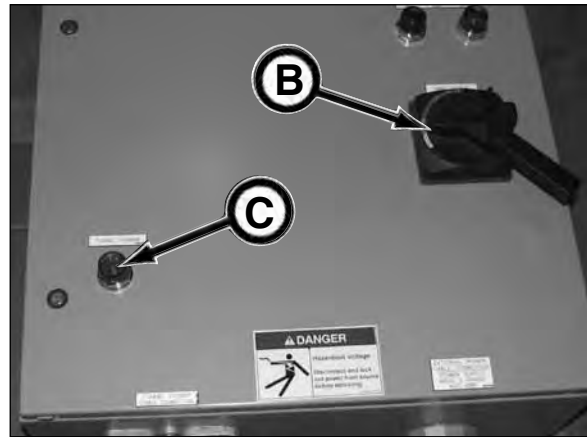

9. Move TBM electrical box main power disconnect switch (E) to the ON position.

10. Check E-Stop button (A) operation; all electrical power must shutdown when pushed in. If E-Stop does not operate correctly, a certified electrician must troubleshoot the problem. With proper operation, pull out E-Stop button to continue start-up procedure.

11. Check gas detection system (F) for proper operation and gas level. Refer to your Gas Detection System Operation manual for more information.

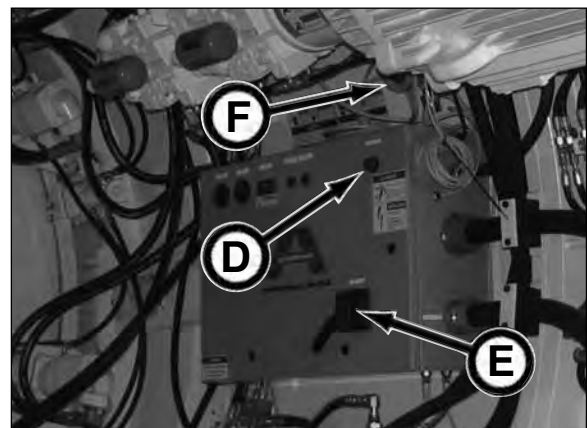

12. If Conveyor Safety switch light (A) is illuminated, the cutter head will not rotate.



13. Be sure conveyor lift safety chains are connected to conveyor and chain from conveyor safety valve switch is fastened to conveyor hook.



14. Check filter indicators. Replace if needed.
15. Check hydraulic reservoir oil level. Add oil if needed (refer to Filling TBM Hydraulic Reservoir in this section).



16. Power up the Boring Head motor by depressing Start button (B)
17. Power up the Auxiliary motor by depressing Start button (C).

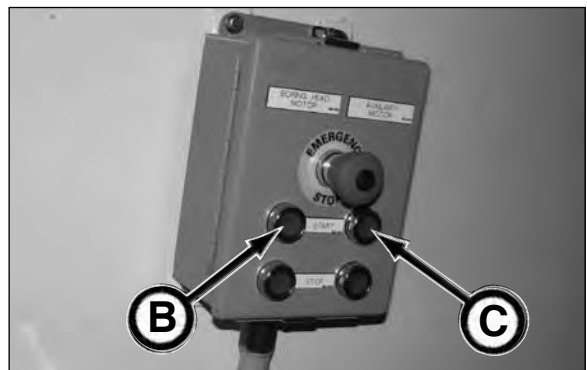

18. Check all hoses and fittings for leaks.
19. Be sure all guards are in place and securely fastened.

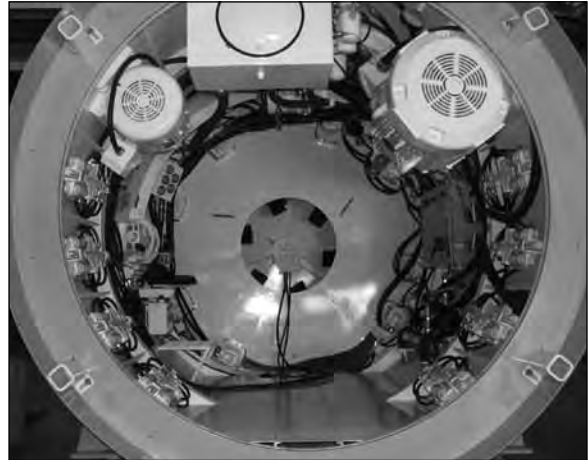

20. SLOWLY operate Conveyor Lift control (A) to determine the proper lift/lower movement speed.

**⚠ WARNING** Adjusting the lift speed too quickly for the operator to handle could cause severe injury or machine damage.

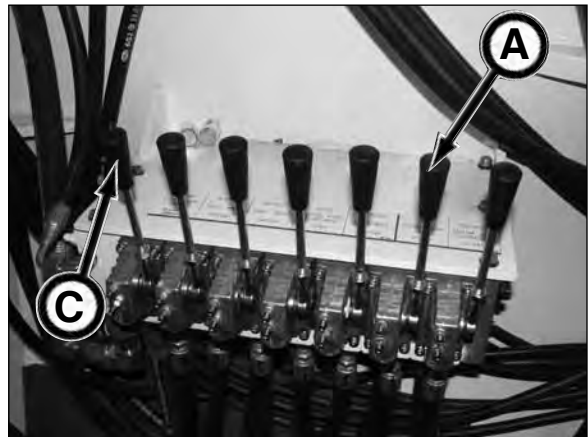

21. Operate conveyor with Conveyor Control (B) and adjust speed as needed.

The further the lever is moved from neutral, the faster the conveyor belt or auger will move. This control also is equipped with a friction detent, so the lever will remain in the desired position until you move it back to neutral position.

The 960B is equipped with an additional conveyor drive control (C) on the 7 bank valve. This control is not equipped with a friction detent.

- 22 Operate the Boring Head Control (D) and adjust rotation speed as needed with lever.

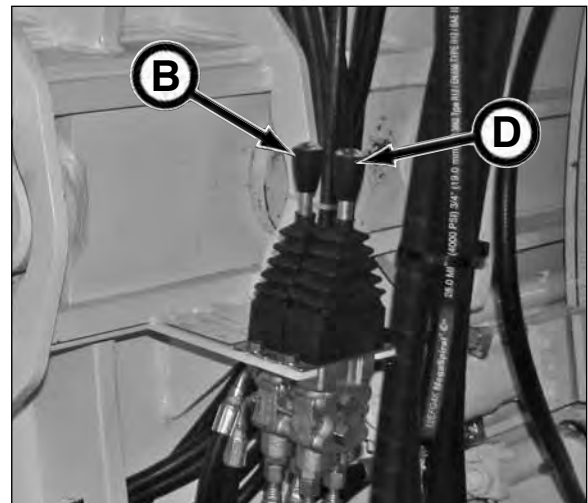

23. Check that the cutter bar mounting bolts are securely fastened.
24. Verify that the TBM operator is able to quickly evacuate the TBM in the event of an emergency.
25. Proceed to Launching The TBM in this section.



## LAUNCHING THE TUNNEL BORING MACHINE

Refer to your 5000 Pump Unit or jacking frame operation manual for proper operation during TBM launch. Keep in mind that the pump unit hydraulics will be used only for the thrust cylinders. The 960B is equipped with an on-board power pack to provide the hydraulics for the TBM functions.

### NOTICE

Perform TBM Start-Up Procedure BEFORE launching TBM.

### NOTICE

NEVER operate equipment if it has been engulfed with water. Contact your Akkerman Aftermarket Support representative for proper procedures on how to restore equipment for operation.

1. Move the conveyor to the operating position where spoils will fall into dirt bucket.

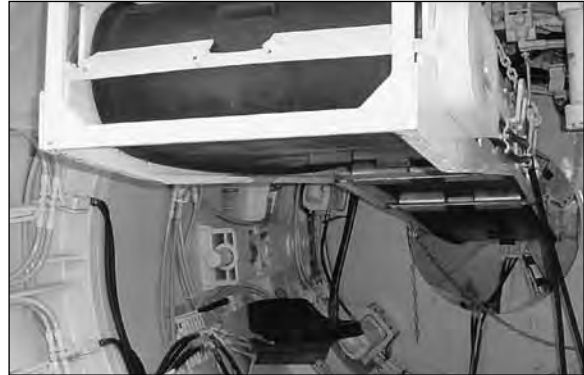

2. Fully extend inner drum advance cylinders with the Inner Drum Advance control (A) and then retract approximately 1/2" (13 mm).

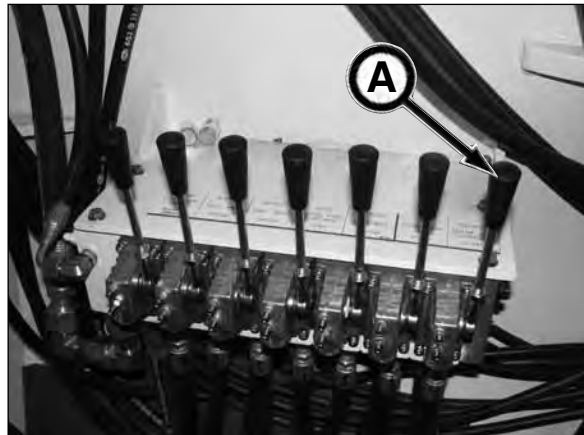

### ⚠ WARNING

Be sure that forward pull exists on the conveyor lifting cables and safety chains throughout the full advance travel. Failure to do so may cause severe injury from conveyor slipping out of the cutter bar center pin.

3. Return the conveyor to the maintenance position.



*(continued on next page)*

**⚠ DANGER** Staring into laser light will cause severe injury. Do not stare into laser guidance system light beam. Avoid direct eye exposure.

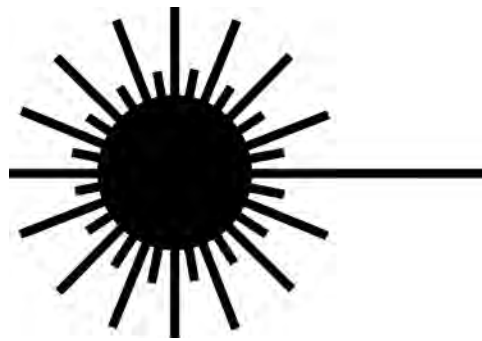

4. Set laser guidance system to grade and alignment, and be sure the laser beam has a clear path to the cutter bar target bolt.

**NOTICE** For proper guidance system installation, refer to your laser manufacturer's installation requirements.

**NOTICE** Typically after TBM is leveled and prior to launching the TBM, some operator's steer 1/2" to 3/4" (13 to 19 mm) up to compensate for the ground conditions at start up. The TBM has a tendency to dip once launched into the ground. This steering adjustment is dependent upon ground conditions.



5. Move the conveyor into the operating position.



6. Lower dirt bucket into position behind the conveyor. Do not install the haul unit at this time.



(continued on next page)

**⚠ WARNING**

Conveyor can jam in rotating cutter head causing conveyor to swing into operator, resulting in severe personal injury. While cutter head is rotating:

1. Operator MUST remain seated in normal operating position.
2. The conveyor safety valve (cutterhead drive dump valve) MUST be tethered to conveyor and the operation MUST be tested before starting the conveyor to insure proper operation.
3. ALL FOUR safety chains MUST be secured to conveyor before operating inner drum.

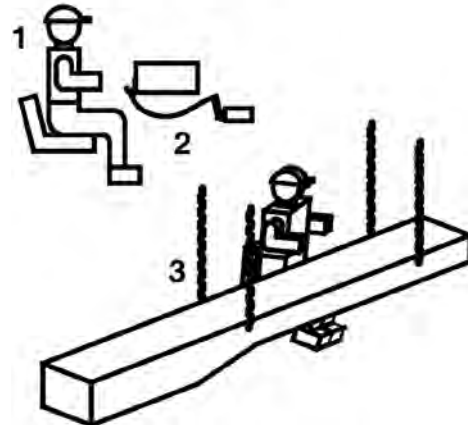

**⚠ DANGER**

Contact with belt conveyor rollers will cause severe injury or death. Keep hands, body, and objects clear of operating conveyor. Do not operate without covers and guards in place. Lockout power before servicing.



**NOTICE**

Refer to Operating The Conveyor in this section for more information.

7. Operate the conveyor with control (A) to desired speed, rotate cutter head with boring head control (B) and apply forward thrust to the TBM from pump unit or jacking frame.

**NOTICE**

Before rotating the cutter head, be sure the cutter teeth will not interfere with jacking system frame.

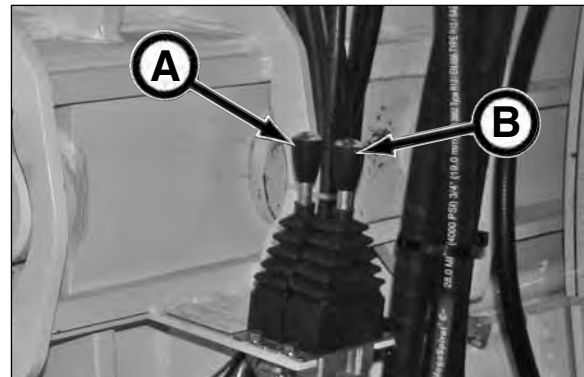

(continued on next page)

**NOTICE**

Use push blocks (A) to push TBM forward so yoke does not damage outside ring of TBM. Remove push blocks before installing first pipe.

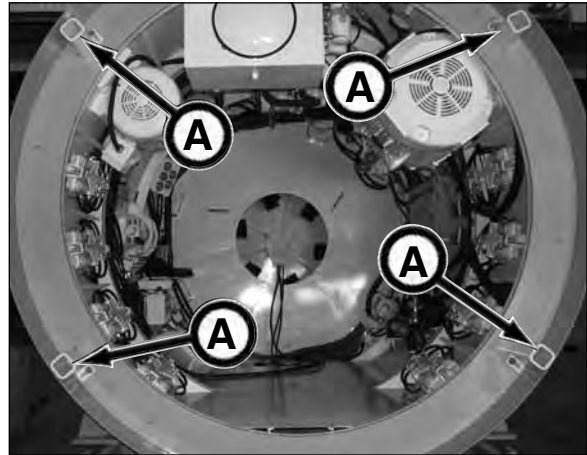

8. When the dirt bucket is full, flip the bucket lift eye up.



**WARNING**

Suspended loads may fall and cause severe injury or death. Do not allow anyone to enter area under or around a suspended load.



9. With a crane or excavator, check for clearances and carefully lift dirt bucket out of unloading area and move to dumping site.



*(continued on next page)*

10. Unload dirt bucket. The dirt bucket is self-dumping when using a two-line crane or when attaching a stationary line.



11. Check if TBM over cut is sufficient to allow steering corrections, but does not exceed job specifications. Readjust over cut (outside cutters are adjustable on dirt head-refer to Adjusting Overcut in this section) and check tooth wear daily and more often in severe conditions.
12. Check and adjust grade and alignment often (after each dirt bucket at a minimum) to avoid misalignment and excessive jacking pressure. Refer to Making Steering Adjustments and Adjusting TBM Roll in this section.

13. Continue operation until the TBM has been advanced forward enough to lower the trailing section of the TBM or the first pipe into place.
14. Shut down the TBM by moving the TBM Main Power switch and the pit box Main Power switch to the OFF position. Return all controls to the OFF or neutral position.

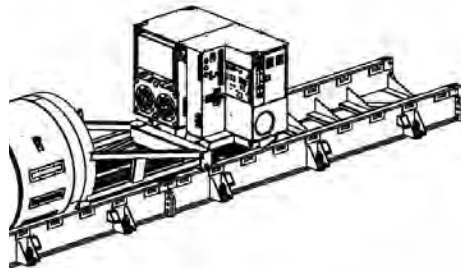

**⚠ DANGER** The Akkerman gas detection system only monitors methane gas levels. Monitoring of gas levels is the responsibility of the contractor. This includes accumulation of combustible and toxic gases, and depletion of oxygen. The contractor must keep the tunnel ventilated with fresh air AT ALL TIMES.

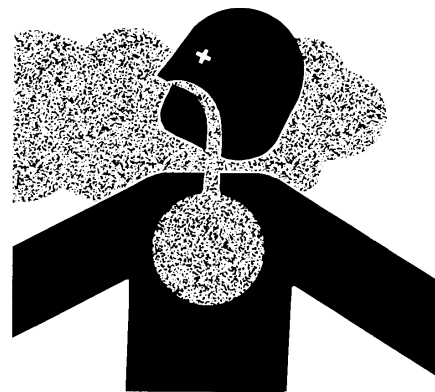

*(continued on next page)*

15. Move the TBM Main Power switch (A) AND the Pit Box main power switch (B) in the OFF position.

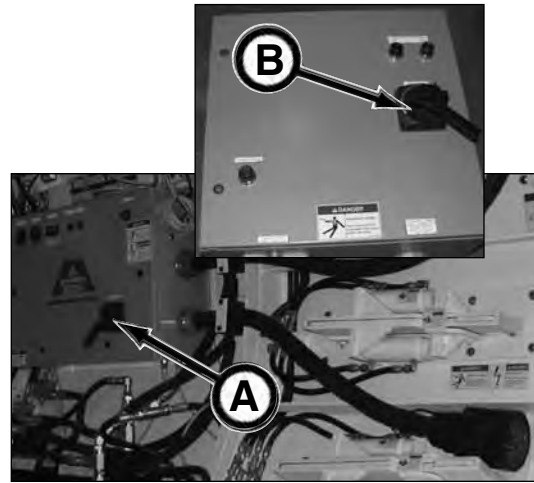

16. Disconnect the ventilation, electrical and communication lines. Once the pipe is in place on the jacking system base, quickly reconnect lines by routing through the next pipe.
17. Retract the pump unit/yoke/jacking frame far enough to lower the first pipe on the jacking system base (skid).



**⚠ WARNING** Suspended loads may fall and cause severe injury or death. Do not allow anyone to enter area under or around a suspended load.



18. Lower the first pipe onto the jacking system base.



*(continued on next page)*

19. Apply forward thrust until the first pipe mates with the TBM.



20. When the first pipe has been set, install the first haul system track (A) and secure to TBM. Refer to Installing Track in the Operation section of your Haul Unit Operator's Manual for track installation.

**NOTICE**

Be sure there is always track connecting the pipeline to the rear of the jacking frame/yoke/jacking frame for the haul unit and the loading and unloading of the dirt bucket.



21. If not already done so, reconnect the ventilation supply line, power cables and communication lines.

**WARNING**

Suspended loads may fall and cause severe injury or death. Do not allow anyone to enter area under or around a suspended load.



22. Lower haul unit onto the track with the operator end of the haul unit installed towards the front of the TBM.



(continued on next page)

23. Recheck laser guidance system accuracy often (both with and without forward thrust applied) to avoid making improper steering corrections. In most situations, the conveyor must be lowered to check line and grade target.

**NOTICE** The more often the target position is checked, the less adjustment that will be required.

**NOTICE** Relevel inner drum every time the target position is checked.



24. Lower dirt bucket into place on the haul unit.

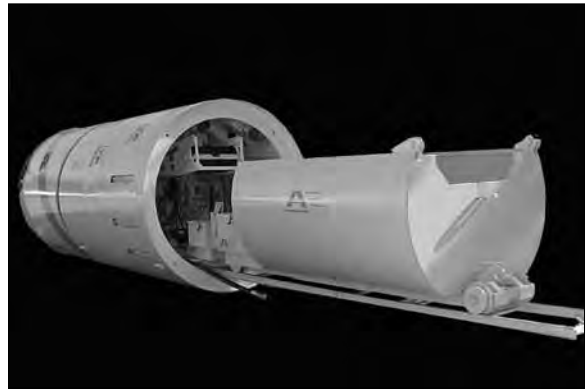

**⚠ WARNING** Avoid contact with conveyor. Failure to do so could cause severe injury or death.

While moving the haul unit into the tunnel, avoid hitting the conveyor and other obstructions.



(continued on next page)

**NOTICE**

For information on operating the haul unit, refer to Operating The Haul Unit in the Operation section of your Haul Unit Operator's Manual.

25. Move the haul unit to the front of the tunnel until dirt bucket is in position to catch spoils from conveyor.

**NOTICE**

Haul Unit track can get slippery. Therefore when operating the haul unit, **GO SLOW!** Also, remember that the haul unit forward momentum will carry the haul unit past the point where the brake is applied.



26. Alert everyone in tunnel and launch shaft areas that the power will be turned on. Once it is safe, move pit box main power switch (A) and TBM main power switch (B) to the ON position.

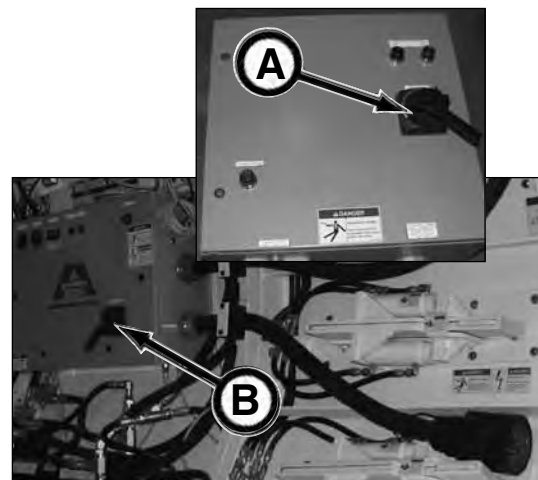

*(continued on next page)*

27. Power up the Boring Head motor by depressing Start button (A)
28. Power up the Auxiliary motor by depressing Start button (B).

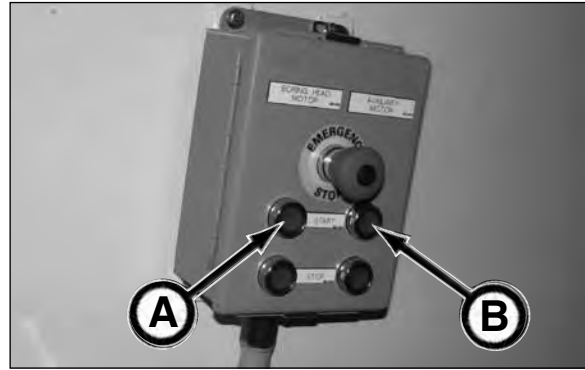

29. Continue pipe jacking process for each additional pipe section (adding power cables, ventilation supply, bentonite hoses, IJS hoses and track as necessary, refer to Adding Pipe in this section) until pipe line is complete. When pipe line is complete, refer to Removing Jacking System in this section.

**NOTICE**

If there is a possibility that the maximum jacking capability will exceed the maximum jacking force of your jacking system or pipe, intermediate jacking stations should be installed (contact your Akkerman Aftermarket Support representative for more information).



## OPERATING THE CONVEYOR

**⚠ WARNING** Conveyor can jam in rotating cutterhead causing conveyor to swing into operator, resulting in severe personal injury. While cutterhead is rotating:

1. Operator **MUST** remain seated in normal operating position.
2. The conveyor safety valve (cutterhead drive dump valve) **MUST** be tethered to conveyor and the operation **MUST** be tested before starting the conveyor to insure proper operation.
3. ALL FOUR safety chains **MUST** be secured to conveyor.

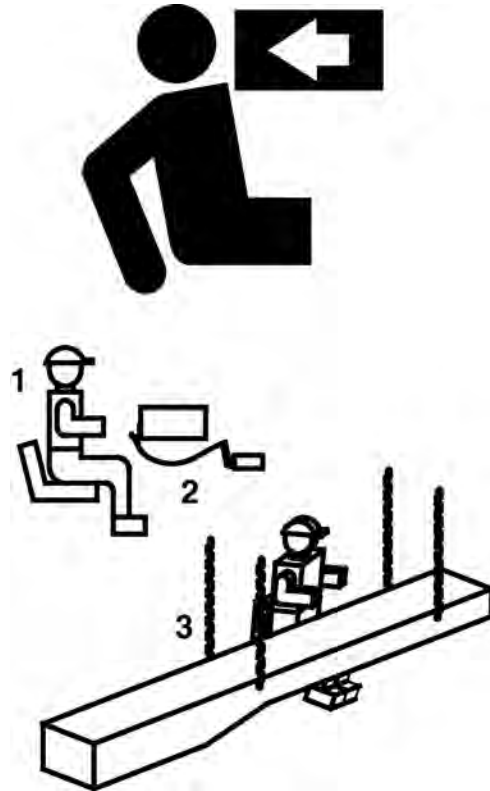

### Conveyor Operation Guidelines:

1. Check conveyor for damage before operating. Repair or replace damage or wear before operating.
2. Operator **MUST** remain seated in normal operating position.
3. Cutter head drive dump valve cable (stop cord) **MUST** be tethered.
4. ALL FOUR safety chains **MUST** be secured to conveyor before operating inner drum.
5. Avoid contact with conveyor.
6. Keep hands, body, and objects clear of operating conveyor.
7. Do not operate without covers and guards in place.
8. Lockout power before performing maintenance or repairs on conveyor.
9. NEVER perform maintenance to conveyor while the conveyor is running.
10. While conveyor is running, DO NOT try to dislodge material from pulleys.
11. NEVER use a shovel, or other hand tool to clean material buildup while the conveyor is running.
12. Before operating conveyor, check to be sure the belt is properly tensioned.

1. With conveyor properly installed and all guards in place, inform all personnel in tunnel that the conveyor is going to start up and to stay clear of the conveyor.
2. Move conveyor into operating position with conveyor lift control (A), using control to adjust lift speed.

**⚠ WARNING** Adjusting the lift speed too quickly for the operator to handle could cause severe injury or machine damage.

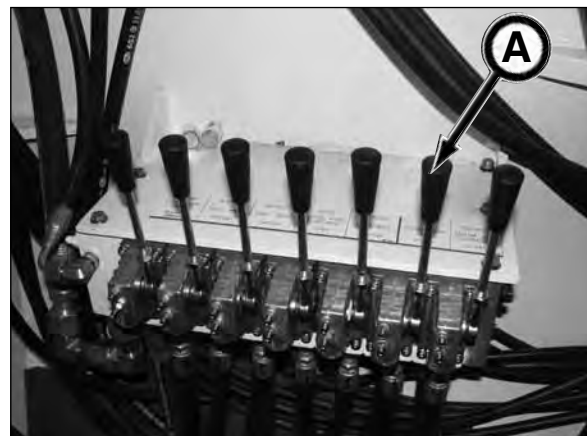

(continued on next page)

3. Move dirt bucket into position to catch spoils from conveyor.

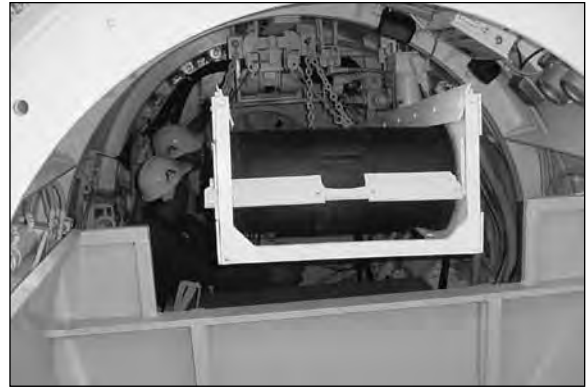

**WARNING** Running the conveyor too fast can cause severe injury from flying debris and cause possible machine damage. Slow the conveyor speed so there is continual controlled movement of the spoils into the dirt bucket.

4. Operate conveyor control (A) to control the direction and speed of the belt or auger conveyor.

The further the lever is moved from neutral, the faster the conveyor belt or auger will move. This control also is equipped with a friction detent, so the lever will remain in the desired position until you move it back to neutral position.

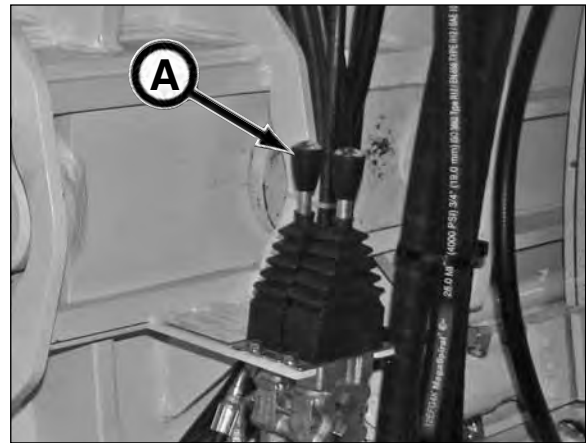

**NOTICE** Control the speed of the conveyor so when the spoils drop on the conveyor, they do not pile up on the belt or in the auger. A change in ground conditions will require periodic adjustments to the conveyor speed.



## MAKING STEERING ADJUSTMENTS

**NOTICE** Steering adjustments are typically made when the dirt bucket is removed from the launch shaft, then the conveyor is lowered to expose the laser beam on the target bolt area.

**NOTICE** The more often the target position is checked, the less steering adjustments will be required.

When steering corrections are necessary, be sure to **make ONLY minor adjustments over several feet**. Making more extreme steering adjustments will increase the jacking forces due to the front and trailing sections are not in parallel.

Use the steering selector (A) to select the grade or alignment adjustment.

**GRADE (up/down):**

Move steering selector (A) UP to select Grade, then operate the steering cylinder control (B) as needed to adjust the steering cylinders accordingly. This will move the front drum up or down. **DO NOT** use steering nut for grade adjustment.

**ALIGNMENT (left/right):**

Move steering selector (A) DOWN to select Alignment.

**Left Turn:** PULL (extend) steering cylinder control (B) while turning steering adjustment nut (C) forward.

**Right Turn:** PUSH (retract) the steering cylinder control (B) while turning steering adjustment nut (C) back.

A steering wrench (D) may be used to rotate nut, otherwise relieve pressure on the nut by slightly moving steering cylinders and rotate nut by hand.

**NOTICE** If steering nut is hard to turn, tap the steering cylinder lever to relieve pressure.

**NOTICE** Move steering nut simultaneously with steering cylinder so that no excessive force is on the nut.

**IMPORTANT: DURING TBM ADVANCEMENT, DO NOT ALLOW STEERING CYLINDER PRESSURES TO EXCEED 3,000 PSI. DOING SO WILL CAUSE HYDRAULIC COMPONENT & STRUCTURAL DAMAGE.**

The top steering cylinder pressure gauge (E) and bottom steering cylinder pressure gauge (F) indicate the active cylinder pressure. The maximum steering cylinder pressure to make steering corrections is 2,800 - 3,000 psi,.

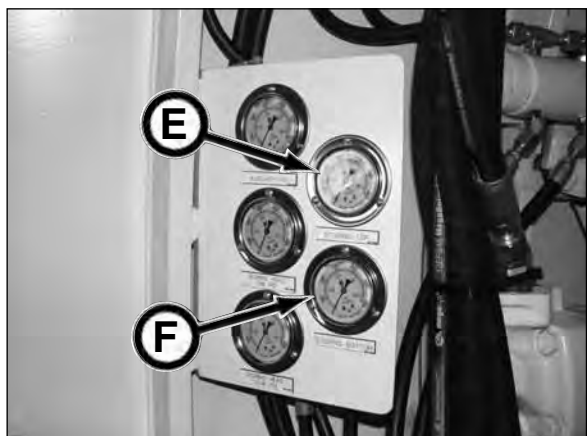
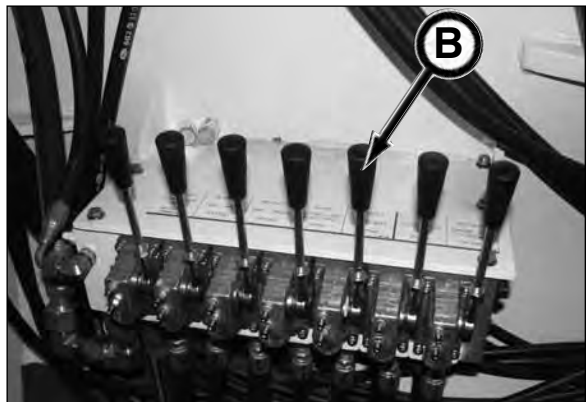
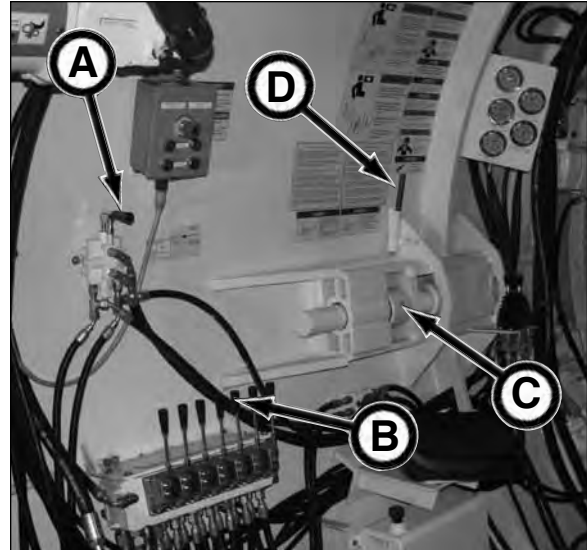

## ACCESSING FRONT OF TBM / ENCOUNTERING AN OBSTRUCTION

To access the front of the machine and the face of the bore, retract the drum advance cylinders (A) with drum advance cylinder control lever (B). Be sure to perform the lockout, tagout procedure before accessing the front of the TBM to prevent accidental startup.

This method allows for the removal of large obstructions, whether planned or unexpected and makes it easy to perform routine maintenance and repairs.

Use drum advance lever as follows:

- PUSH - Retract drum advance cylinders
- PULL - Extend drum advance cylinders

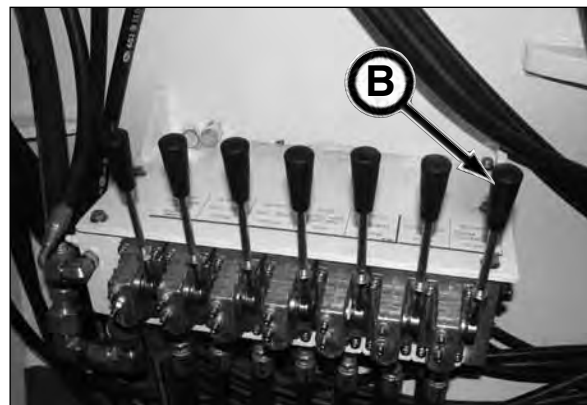
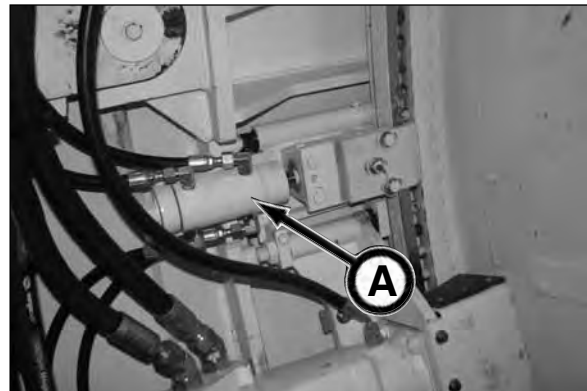

## ADJUSTING OVERCUT (DIRT HEAD ATTACHMENT ONLY)

The typical overcut is 1.50" (38 mm) larger than the product pipe diameter, which allows space for steering and the addition of bentonite. Keep in mind that too large of an overcut can lead to uncontrollable steering. Contact your Akkerman Aftermarket Support representative if your desired overcut is more than 1.50" (38 mm).

1. Loosen nut (C), set screw (D), and nut (E).
2. Readjust bolt (F) to move cutter (G) to desired overcut.
3. Retighten nut (E).
4. Retighten set screw (D).
5. Retighten nut (C).

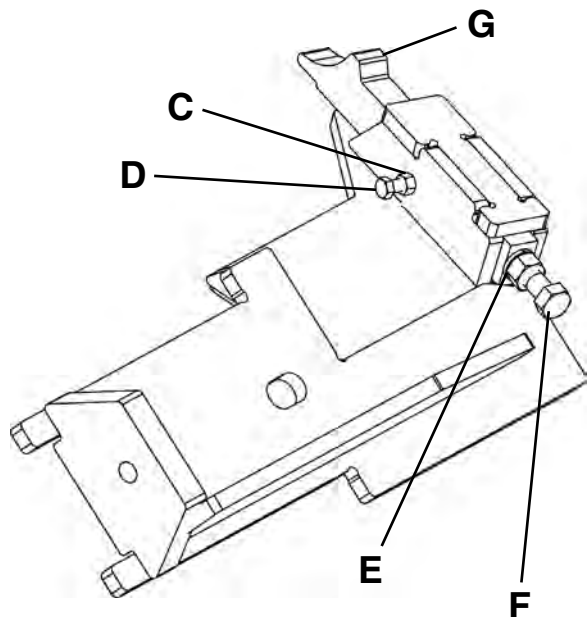

## ADJUSTING TBM ROLL

**NOTICE** The clockwise (CW) and counterclockwise (CCW) directions listed below are referenced from the launch shaft going forward to the reception shaft.

If the TBM rolls 1/4" to 1/2" (6 to 13 mm) from level, the dirt wings (A) need to be extended. The dirt wings are fully extended when the auxiliary pressure gauge (B) reads 2,800 - 3,000 psi.

Control the TBM roll with dirt wing levers (C,D) as follows:

### CW Roll Control

Dirt Wing Control (C) will regulate the top two left dirt wings (E) and the bottom two right dirt wings (F). Using this control will roll the TBM in a CW direction.

### CCW Roll Control

Dirt Wing Control (D) will regulate the top two right dirt wings (G) and the bottom two left dirt wings (H). Using this control will roll the TBM in a CCW direction.

Keep the dirt wings extended until the TBM roll is back to level position.

**NOTICE** Do not use both the CW and CCW dirt wings simultaneously. Doing so will create excess friction requiring more thrust to advance the TBM and will cause damage to the dirt wings.

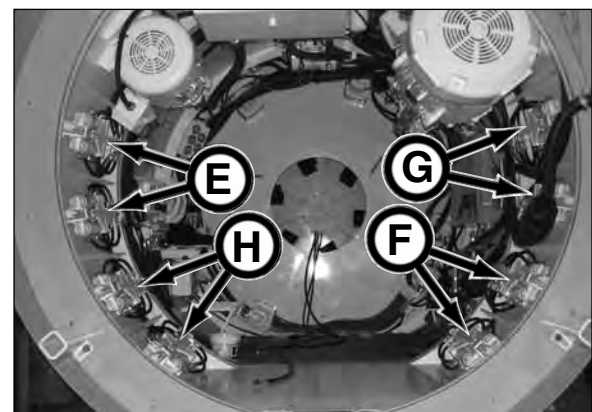
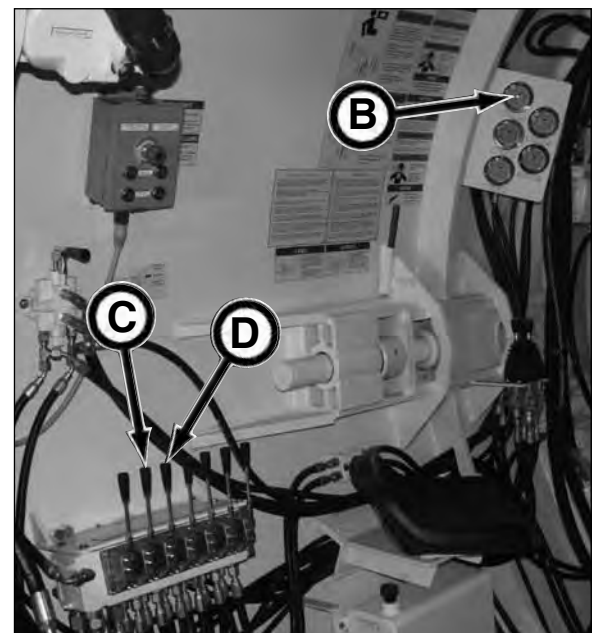
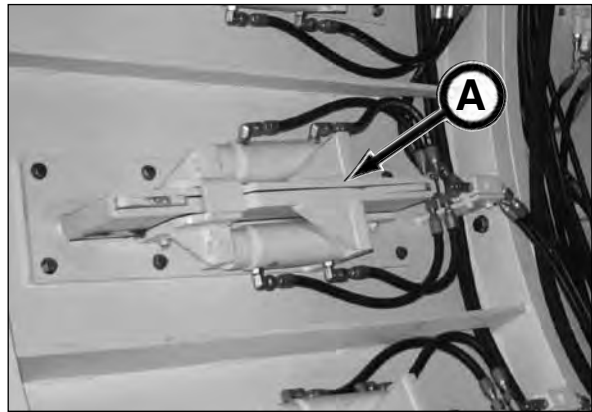

---

## USING GAS DETECTOR

Refer to your Gas Detection System Operation & Parts Manual for properly operating the gas detector.

**⚠ DANGER** Be aware that the harmful effects of entering an oxygen-deficient atmosphere can be so immediate that it is impossible to retreat to safety.

The gas detection system installed in the TBM system, monitors only methane gas levels.

**Monitoring of all gas levels is the responsibility of the contractor.** This includes the accumulation of combustible and toxic gases, and depletion of oxygen. The contractor must keep the tunnel ventilated with fresh air.

The gas detection system installed in the TBM CANNOT be the only methane or other combustible monitoring system. The gas concentration must be checked by other portable detectors to inspect the tunnel at the beginning of each shift to determine that the tunnel is gas free before any tunnel equipment is energized or personnel are allowed to enter the tunnel. The contractor is responsible for providing air analyzers to detect hazardous gases or oxygen deficiency on the job and in the tunnel at all times.



---

## USING HAUL UNIT

**⚠ WARNING** Contacting tunnel wall and boring head components can cause severe injury or death. Keep all body parts on Haul Unit while unit is moving.

Refer to your Haul Unit Operator's Manual for the proper safety, operation, and maintenance information.

Keep all tooling or other support equipment off of the haul unit.



## USING CLOSED FACE OR AUXILIARY CONTROL

The Closed Face lever (A) controls the opening and closing of the doors on the optional closed face cutter head attachment. Used in unstable ground conditions, the hydraulically operated doors control subsidence of loose soil while excavating the ground.

Move the lever as follows:

- PUSH - close doors (extends cylinders)
- PULL - open doors (retracts cylinders)

A lubrication system (two water/lubrication ports on cutter head) is equipped on the closed face attachment to provide a method to lubricate the face if needed.

Operating Guidelines:

1. BEFORE operating closed face, extend drum advance cylinders only enough to turn the inner drum without interference with TBM.
2. Connect water/lubrication hose to 1/2" fitting on closed face attachment to lubricate clay or abrasive materials.
3. Open doors only as needed while advancing to prevent over excavating.
4. When retracting steering cylinders for closure of closed attachment to TBM cutter ring, monitor pressure gauge for pressure spike indicating closed face closure.
5. When using closed face attachment, check wear of inner drum rollers frequently as they will wear unevenly.
6. At each shift change, or at the end of the day, close doors and completely retract inner drum to prevent material flow into the TBM.

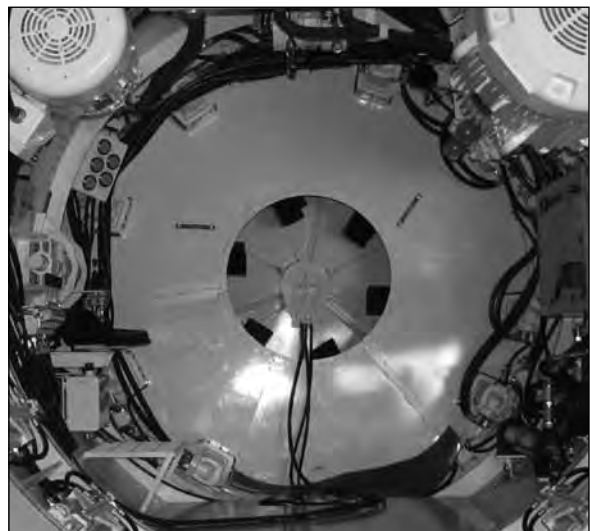
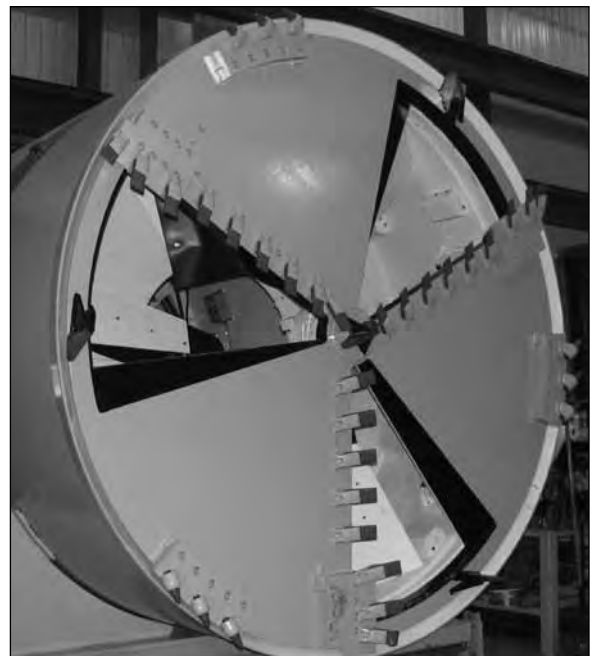
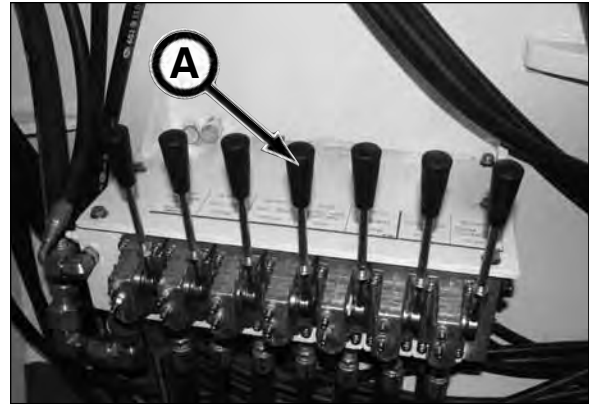

## ADDING PIPE

**⚠ WARNING** Suspended loads may fall and cause severe injury or death. Do not allow anyone to enter area under or around a suspended load.

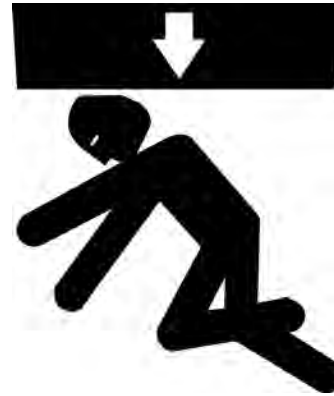

1. Continue jacking until the TBM has been jacked far enough into the ground to allow adequate space to add one section of pipe.

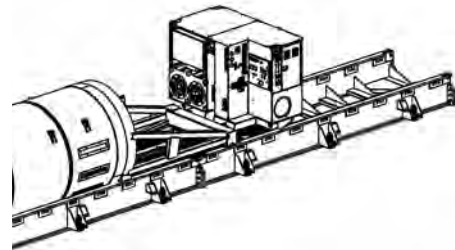

2. Return all controls on the pump unit/jacking frame and TBM to the OFF or neutral position.



3. Stop the boring head and auxiliary motors by depressing the Boring Head STOP button (A) and the Auxiliary Motor STOP button (B).

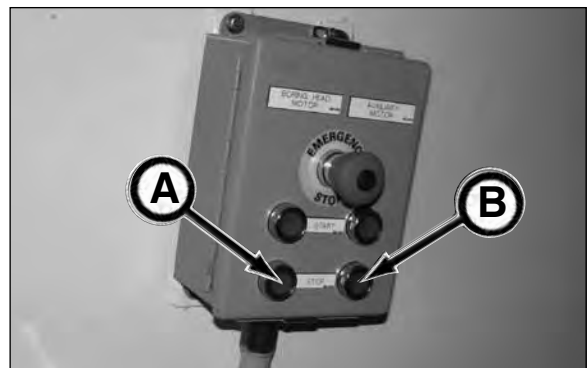

*(continued on next page)*

**⚠ DANGER** Contact with electrical power WILL cause severe injury or death from electrical shock. NEVER disconnect tunnel power cables when tunnel power light is ON.



4. Move the TBM main power switch (A) and the pit box main power switch (B) to the OFF position. Place pit box switch in lockout/tagout to prevent any accidental powering of TBM.

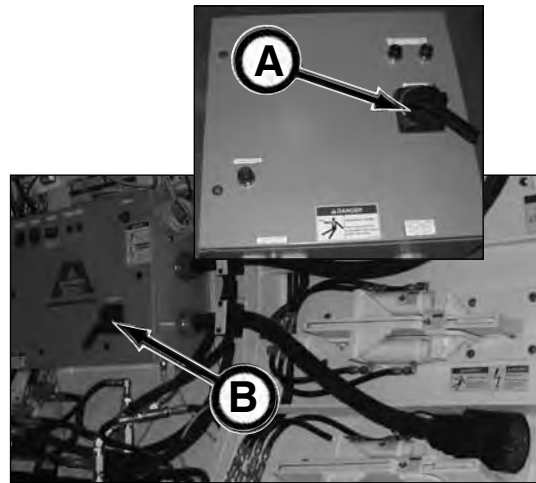

5. Push IN TBM E-Stop (C).



*(continued on next page)*

**⚠ DANGER** Contact with electrical power WILL cause severe injury or death. NEVER disconnect tunnel power cables when tunnel power light is ON. The tunnel power switch MUST be in lockout/tagout before connecting or disconnecting power cables.



6. Disconnect the 480V electrical cable, communication line, ventilation supply, water supply hoses, bentonite hoses (if used), and IJS hydraulic hoses and cable (if used). Be sure all electrical lines, hose connections and cables are positioned in a clean, dry location and are out of the way of the next pipe, and any pinch point areas.

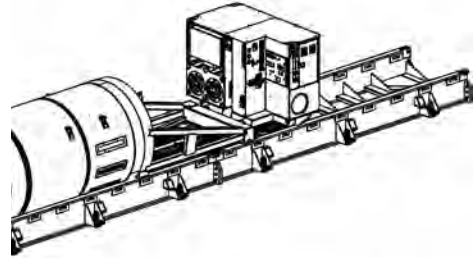

7. Disconnect track from pipeline.

8. Perform a visual machine inspection by checking the following items: all fluid levels, leaks, filter indicators and machine damage. Make repairs before operating.



9. Retract pump unit and yoke/jacking frame back far enough to lower a section of pipe.

10. Lower the next pipe into shaft and wipe off and lubricate the sealing ring to ensure proper sealing before setting pipe.



*(continued on next page)*

11. Use pump unit/jacking frame controls to travel to back of pipe and mate the yoke with the pipe.



12. Use pump unit/jacking frame controls to mate pipe with TBM.



**⚠ DANGER** Contact with severed electrical cables WILL cause severe injury or death. Constantly monitor electrical cables during the jacking process to prevent cutting or stretching of any electrical cables.



13. Clean electrical and hose connections before reinstalling.
14. Reinstall ventilation supply, 480V electrical cable, communication line, bentonite hoses (if used), and IJS hydraulic hoses and cable (if used).

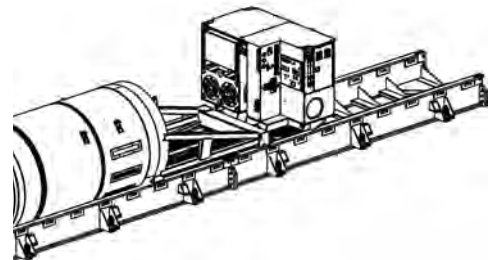

*(continued on next page)*

15. Install new pipe track to pipeline track. Sections of track will need to be added as new pipe is lowered. Be sure there is always track connecting the pipeline and the yoke/jacking frame for the haul unit and the loading and unloading of the dirt bucket.



16. Once it is communicated to all job site personnel that the TBM power and the machine operation will be resumed, remove lockout/tagout from pit box main power switch (A).

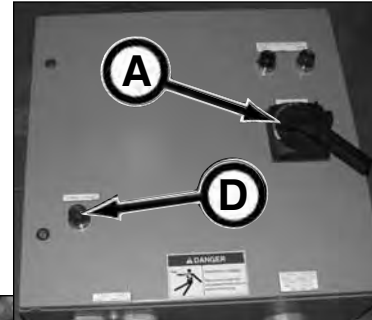

17. Pull out E-Stop button (B).

18. Move pit box main power switch (A) and TBM main power switch (C) to the ON position. This will illuminate the Tunnel Power light (D) and the Incoming Power light (E) which provides the operator a quick visual indicator that power is ON in the tunnel and to take all necessary precautions with high voltage electricity.

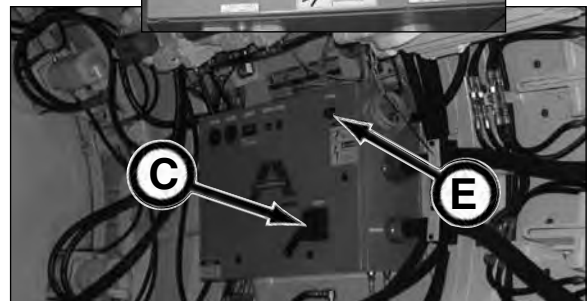

19. Power the Boring Head motor by depressing Start button (F)

20. Power up the Auxiliary motor by depressing Start button (G).

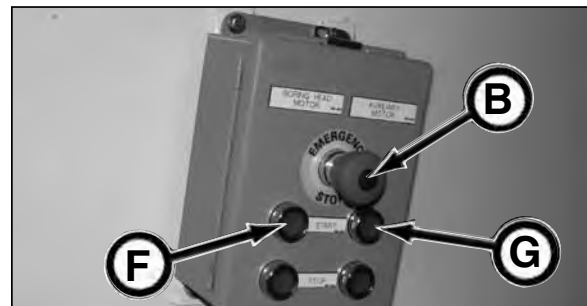

**▲ DANGER** Staring into laser light will cause severe injury. Do not stare into laser guidance system light beam. Avoid direct eye exposure.

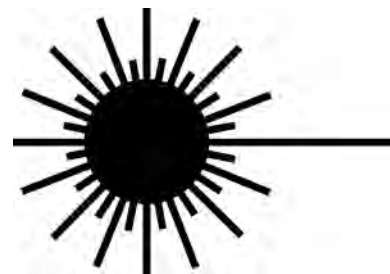

21. Recheck laser guidance system accuracy often, with and without forward thrust applied, to avoid making improper steering corrections.

22. Repeat pipe installation for subsequent pipe.



## FILLING TBM HYDRAULIC RESERVOIR

The 960B TBM is equipped with a fill quick coupler connection for pumping hydraulic oil through the auxiliary filter before entering hydraulic reservoir.

1. Be sure tank breather valve (A) is open. The tank breather valve should always be open except during shipping or moving the TBM.
2. Connect male quick coupler end (B) to customer supplied fill hose end.
3. Clean area around female quick coupler (C).
4. Connect fill hose with male quick coupler to female quick coupler.
5. Start pump (customer supplied) to fill reservoir with CLEAN ISO-VG-68 20W Premium hydraulic oil or equivalent.

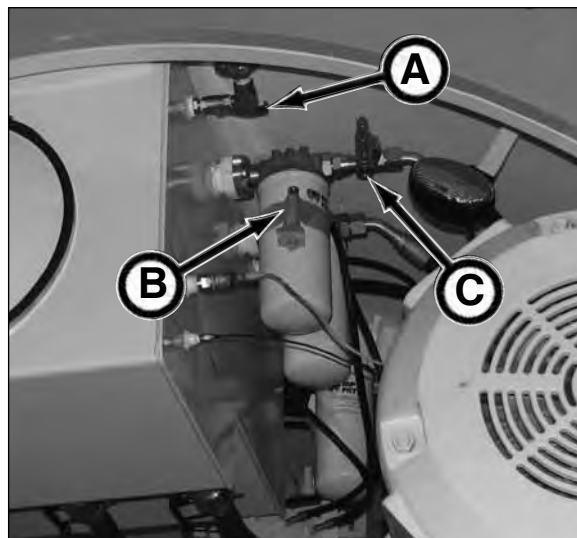

6. Carefully watch the tank volume on the level gauge (D) so the oil in the tank will not overflow. The reservoir capacity is 75 gal. (284 L).

7. Once reservoir is filled, remove fill pump hose with male quick coupler.

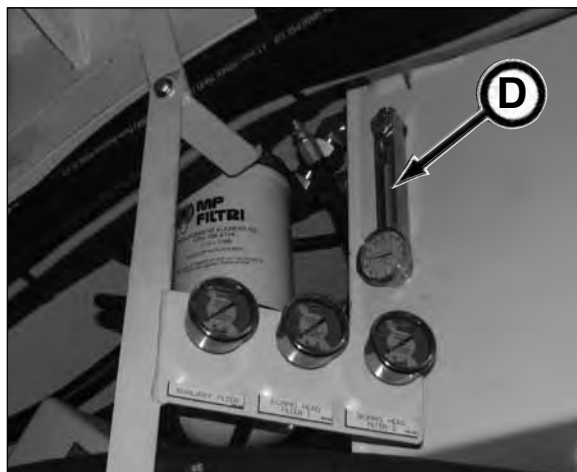

## DAILY SHUT DOWN

1. Return all controls on the pump unit/jacking frame and TBM to the OFF or neutral position.
2. Stop the boring head and auxiliary motors with STOP buttons (A).
3. Shut off water supply to TBM oil coolers (B)  
Drain water if freezing temperatures are possible.
4. Shut off water supply to pump unit heat exchanger. Drain water if freezing temperatures are possible.
5. Move the TBM main power switch (C) to the OFF position.
6. Push IN TBM E-Stop button (D).
7. Move the pit box main power switch (E) to the OFF position.
8. Lockout/tagout pit box main power switch.
9. Lockout/tagout main power source.
10. Shut down pump unit/jacking frame (refer to operation manuals). Lockout/tagout power.
11. Perform a visual system inspection by checking the following items: all fluid levels, leaks, and machine damage. Make repairs before operating. Also check to be sure all electrical and hydraulic connections are properly connected and secured.
12. If not already installed, install sump pumps in the launch and reception shafts to keep shafts dry.

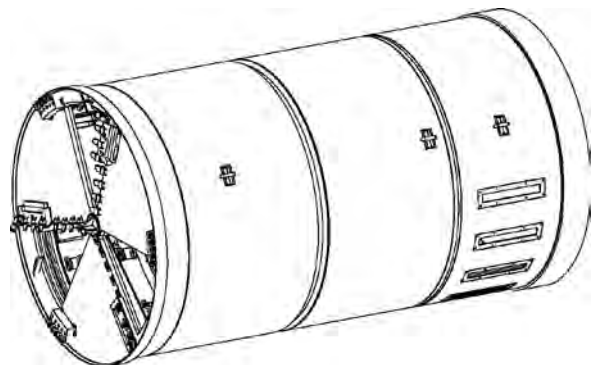
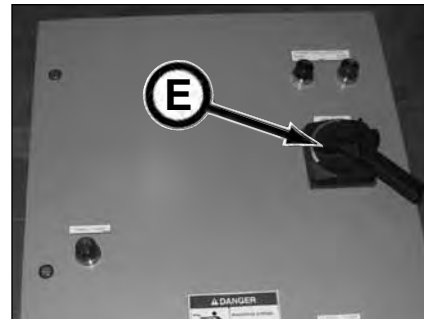
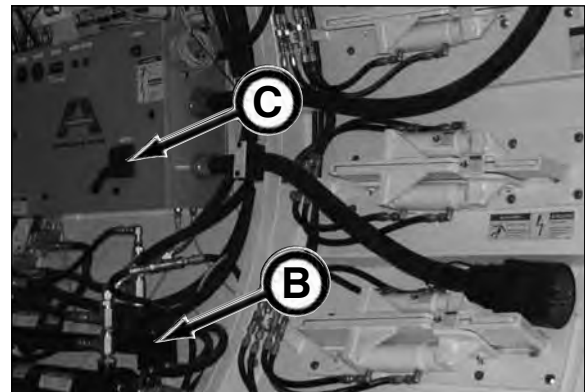
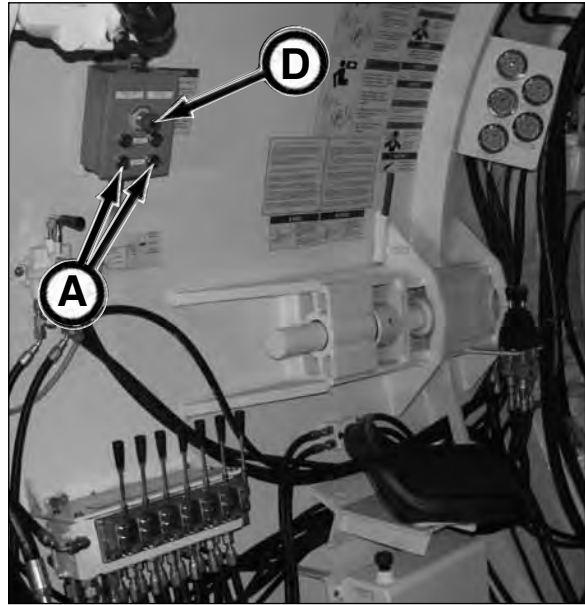

### NOTICE

The pump unit and TBM should not be engulfed with water. Damage will result. If equipment becomes engulfed with water, contact your Akkerman Aftermarket Support representative for proper procedures on how to restore equipment for operation.

## REMOVING TBM AND JACKING SYSTEM

**⚠ WARNING** Any electrical work completed on the TBM and jacking system **MUST** be performed by a certified electrician.

When pipe line is complete and TBM is in reception shaft, remove the TBM as follows. For pump unit or jacking system removal, refer to your operation manual.

1. Shutdown the Boring Head motor by depressing Stop button (A)
2. Shutdown the Auxiliary motor by depressing Stop button (B).

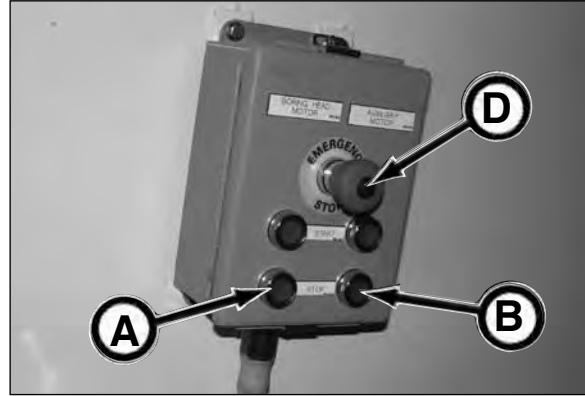

3. Move TBM main power switch (C) to the OFF position.
4. Push IN E-Stop button (D).

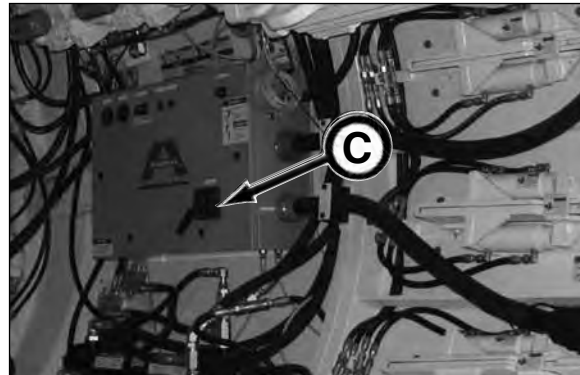

5. Move pit box main power switch (E) to the OFF position.
6. Lockout/tagout pit box main power switch.
7. Lockout/tagout main power source.

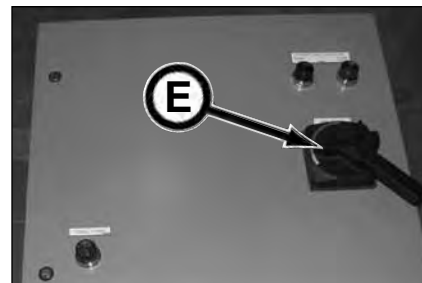

*(continued on next page)*

**⚠ WARNING** Failure to lockout power before servicing can cause severe personal injury or death.

This TBM contains high voltage electricity.

LOCKOUT main power supply before servicing.  
Electrical repairs must be performed only by a certified electrician.



8. Disconnect electrical power cables and store them in a clean, dry location.

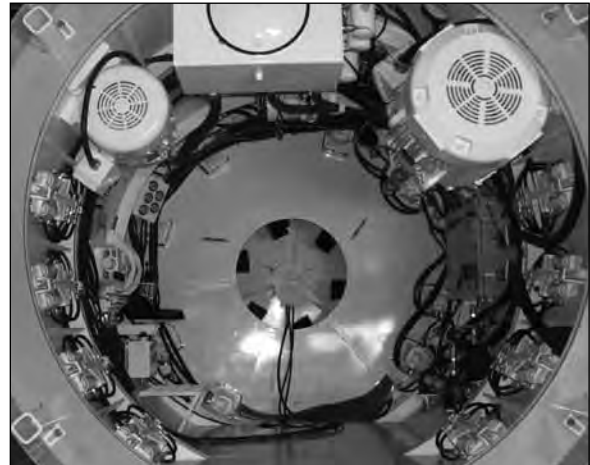

**⚠ WARNING** Escaping oil or other fluids under pressure can penetrate your skin causing serious injury or death.

Release all pressure before performing maintenance or repairs. Never weld near pressurized fluid lines.

DO NOT use your hands to check for leaks.  
When searching for leaks, use a piece of wood or cardboard.

Contact medical help immediately if any oil or fluid is injected into your skin. A serious infection or reaction can emerge without proper medical treatment.



9. Release pressure on hydraulic hoses. Disconnect IJS hydraulic hoses (if used); reclaim hydraulic oil in hoses. Store hoses in a clean, dry location.

10. Disconnect communication line, ventilation supply, water supply lines, bentonite hoses (if used), and IJS hydraulic hoses and cable (if used). Store water lines, hoses and cable in a clean, dry location.

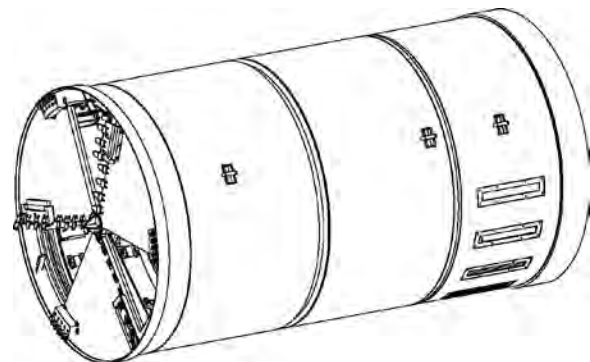

*(continued on next page)*

**NOTICE**

If using Intermediate Jacking Stations (IJS), the outer shell will remain in pipe line.

11. If IJS are used:
  - a. remove IJS #1 valve, cylinder segments, and cap hoses, lines, valve and cylinder ports. Cut off valve and cylinder segment bolts. Close IJS #1 gap by operating IJS #2.
  - b. remove IJS #2 valve, cylinder segments, and cap hoses, lines, valve and cylinder ports. Cut off valve and cylinder segment bolts. Close IJS #2 gap by operating IJS #3.
  - c. remove IJS #3 valve, cylinder segments, and cap hoses, lines, valve and cylinder ports. Cut off valve and cylinder segment bolts. Close IJS #3 gap by operating jacking cylinders (if IJS #3 is the last IJS).

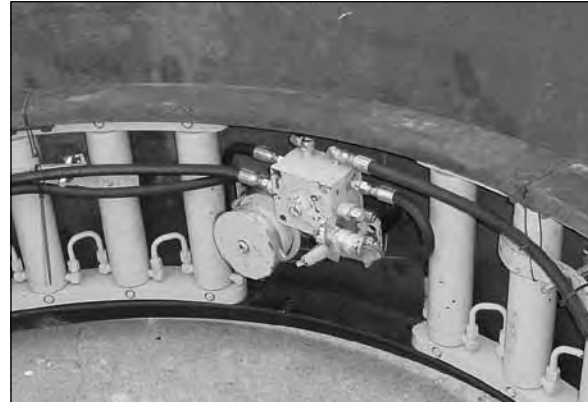

**WARNING**

Suspended loads may fall and cause severe personal injury or death. Do not allow anyone to enter area under or around a suspended load.



**WARNING**

Tunnel boring machine is top heavy. Any unintended movement may cause TBM to roll, resulting in serious injury or death upon contact.

Use EXTREME caution while handling TBM to prevent rolling.



**WARNING**

Contact with rolling tunnel boring machine can cause serious injury or death.

ALWAYS use cradles to secure TBM from rolling during transport.

12. Remove TBM (add cradles to TBM to prevent rolling), haul unit and track.
13. Remove pump unit/jacking frame, yoke and skid(s).



*Operation*

## **NOTES**

# Transporting

## TRANSPORTING GUIDELINES

**⚠ WARNING** Suspended load may fall and cause severe personal injury or death.

Do not enter area under or around a load.



1. Know the local, state, and federal transportation regulations.
2. Obtain required permits for transporting.
3. Close tank breather valve (A) before moving or transporting TBM to prevent hydraulic oil from spilling out of the breather. Breather valve must be opened after transport to prevent pressure buildup in tank.
4. Remove any obstacles from the trailer floor.
5. Clean debris from equipment.
6. Load and unload on level ground.
7. If lifting equipment with a hoist or other lifting device, the equipment lifting eyes and sling must be inspected for damage before lifting. If damaged, replace.
8. ALWAYS use cradles to secure TBM from rolling during transport.
9. Securely fasten equipment to trailer floor.
10. Secure all loose items.
11. Observe the lifting instructions on the following page.

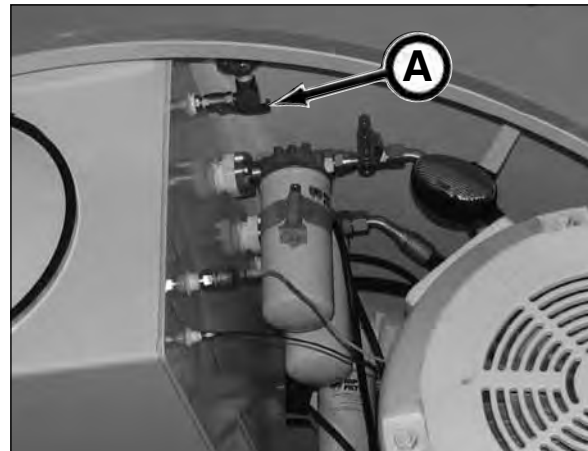

## LIFTING INSTRUCTIONS

### Handling TBM

Tunnel boring machine is top heavy.

Any unintended movement may cause TBM to roll, resulting in serious injury or death upon contact.

Use **EXTREME** caution while handling TBM to prevent rolling.

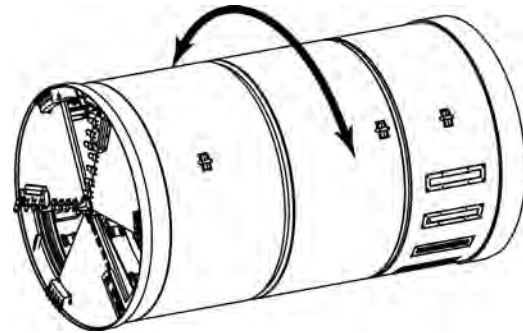

### Use Cradle Supports During Transport

Contact with rolling tunnel boring machine can cause serious injury or death.

**ALWAYS** use cradles to secure TBM from rolling during transport.

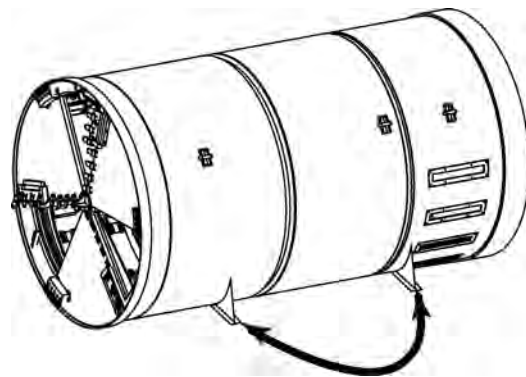

### 960B TBM (SN 30750F) Lifting Instructions:

- 960B tunnel boring machine weight is 60,000 lbs. (27,216 kg).
- Lifting with a crane requires a six part sling with the four outer legs a minimum of 25 ft. (7.62 m) long.
- TBM must lift freely. If it is stuck to the ground, it must be broken loose prior to lifting.
- TBM lifting eyes must be inspected prior to each lift. Any damage must be repaired prior to lifting

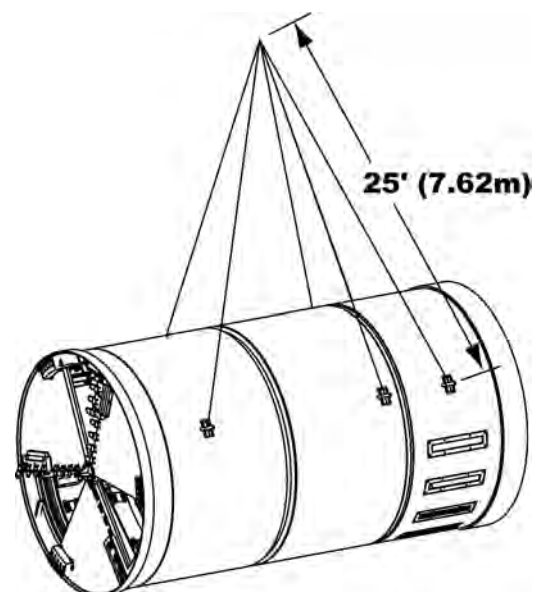

# Lubricants

## NOTICE

Use of inferior lubricants can affect the efficient performance of your tunnel boring machine equipment. Always use high quality lubricants as specified in this section. Refer to the Periodic Maintenance section for proper lubrication quantity, and maintenance intervals.

Refer to your pump unit/jacking frame and haul unit operation manuals for proper lubricants.

## HYDRAULIC RESERVOIR LUBRICANT

The 960B hydraulic reservoir is filled with ISO-VG-68 20W Premium Hydraulic Oil.

The hydraulic reservoir capacity is 75 gal. (284 L).

## NOTICE

If using a too heavy of viscosity oil in cold temperatures, hydraulic oil pump damage could result due to pump cavitation. On the contrary, using ISO 32 oils above 150°F operating temperatures (oil temp. in reservoir) will result in reduced hydraulic power to functions.

Recommended hydraulic oil:

Ambient Temp.	Hydraulic Oil
-25°F to 60°F (-32°C to 16°C)	ISO 32
0°F to 95°F (-18°C to 35°C)	ISO 46
32°F to 105°F (-0°C to 41°C)	ISO 68

## NOTICE

If you change to a different oil, use a reputable oil supplier to meet or exceed the ISO-VG-68 or API GL-1/GL-2 oil specification. Do not mix oil manufacturers or grades.



## ELECTRIC MOTOR BEARING GREASE

The electric motor lubrication grease fittings are lubricated with Mobil Polyrex® EM grease.

The Polyrex EM grease is a specially formulated grease for electric-motor bearings.

Use Mobil Polyrex® EM grease or equivalent when lubricating the lubrication fittings.

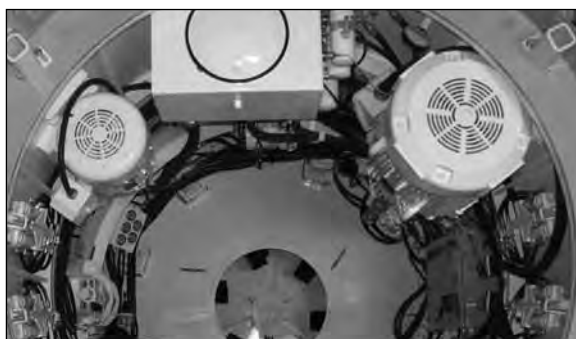

---

## GREASE

The lubrication fittings are greased with Mobilgrease® XHP222 Premium Lubricating Grease unless otherwise specified.

The XHP222 grease is a multi-purpose, high performance, high temperature, lithium grease.

Use Mobilgrease® XHP222 Premium Lubricating Grease or equivalent when lubricating the lubrication points.



---

## STORING LUBRICANTS

Your equipment can operate at maximum performance only if clean lubricants are used. Use clean containers to handle all lubricants.

Lubricants should be stored in an area protected from dust, moisture, and other contaminants.



# Periodic Maintenance

**⚠ WARNING** Review the Safety section in this manual before performing maintenance. Failure to do so, could cause severe injury or death.

Maintenance and repairs must only be performed by a qualified service technician.

---

## LUBRICATION & MAINTENANCE INTERVALS

The requirements for lubrication and maintenance are shown on the maintenance charts in this section.

Intervals of maintenance are based on normal operating conditions. If operating under more difficult conditions, use a shorter time interval between maintenance.

Use the motor hourmeters to help determine proper maintenance intervals.

The hourmeters register in full hours and 1/10ths hours.



---

## BEFORE PERFORMING MAINTENANCE

1. Push IN all E-Stop button(s).
2. Relieve hydraulic pressure.
3. Do not work on hydraulic system if oil temperature exceeds 125° F (51° C).
4. **Lockout all power. Perform lockout/tagout procedure.**



---

## LOCKOUT POWER BEFORE SERVICING

**⚠ WARNING** Severe personal injury or death can result from unexpected pump unit startup or machine movement.

LOCKOUT power before attempting to make repairs or adjustments to this equipment, unless otherwise indicated. Proper lockout will prevent accidents and save lives. Performing the lockout will also prevent the equipment from moving or operating unexpectedly.



---

## HYDRAULIC OIL/FLUIDS UNDER PRESSURE

**⚠ WARNING** Escaping oil or other fluids under pressure can penetrate your skin causing serious injury or death.

Release all pressure before performing maintenance or repairs. Never weld near pressurized fluid lines.

DO NOT use your hands to check for leaks. When searching for leaks, use a piece of wood or cardboard.

Contact medical help immediately if any oil or fluid is injected into your skin. A serious infection or reaction can emerge without proper medical treatment.



---

## AVOID PINCH POINTS

**⚠ WARNING** Moving parts or the mishandling of parts can cause severe personal injury.

Keep hands away from moving parts.

Watch your fingers, hands, and legs while equipment is in operation.

Handle parts carefully to avoid crushing and pinch point hazards.



## WELDING

### UNAUTHORIZED WELDING

**⚠ WARNING** Unauthorized welding can cause structural failure resulting in possible injury or death.

Do not weld on any structural member. Unauthorized welding or repair will void the warranty.

### WELDING ON TBM STRUCTURE

**NOTICE** Welding on TBM structure will damage the GASMAX gas detector.

BEFORE performing authorized welding on TBM, remove the GASMAX gas detector by removing two mounting bolts and the four pin electrical connector.

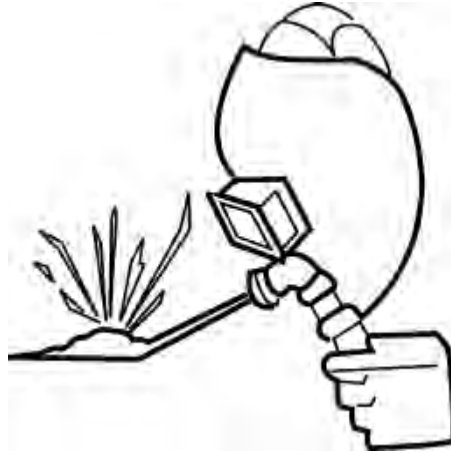

## MAINTENANCE CHARTS - TBM

Use the item number in the chart to refer to the detailed maintenance procedures later in this section.

**NOTICE**

The belt conveyor maintenance is located later in this section.

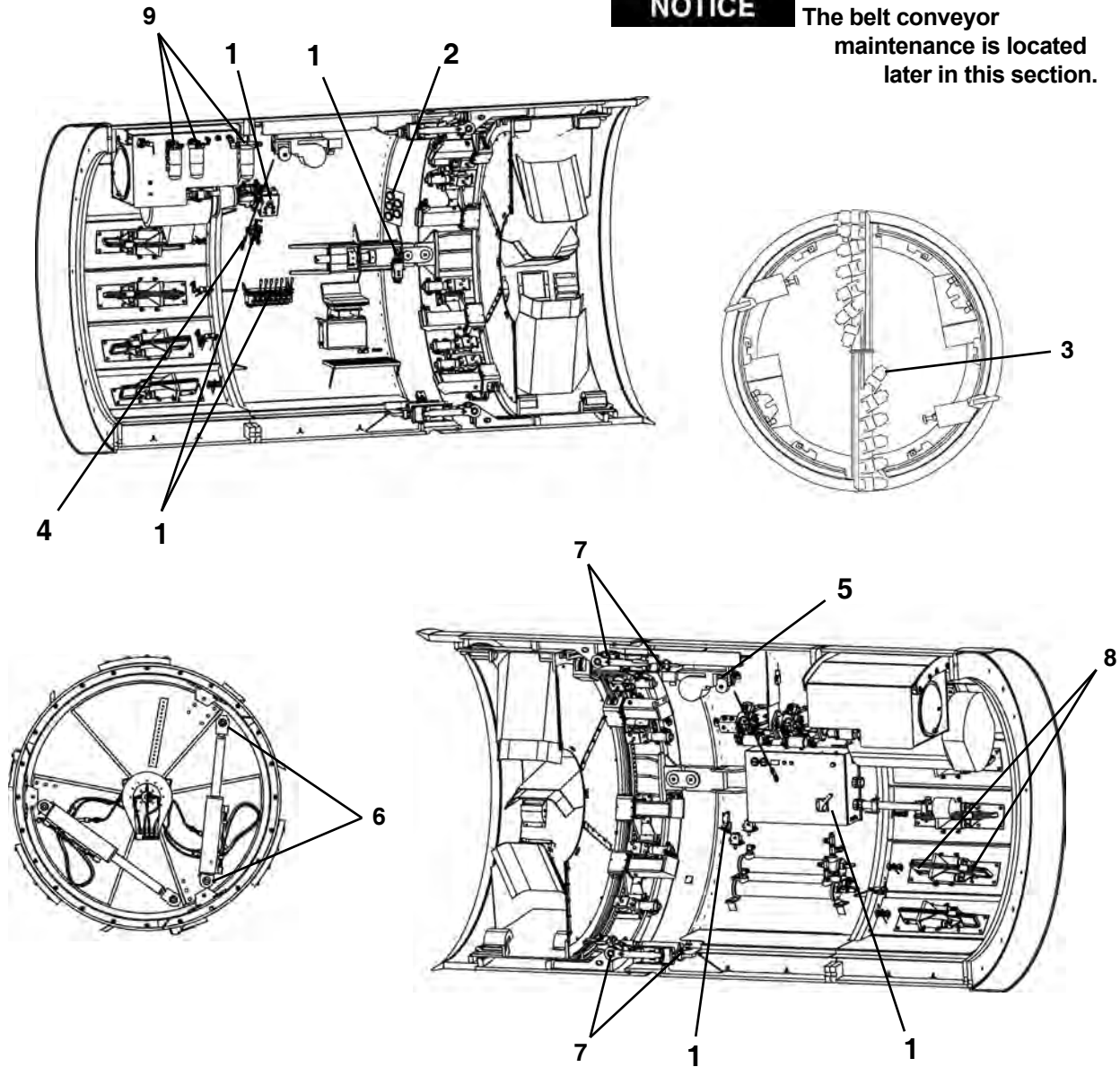

**PRIOR TO EACH JOB LAUNCH**

ITEM	COMPONENT	SERVICE	REQUIREMENT	MATERIAL
1.	Controls	Check Operation		
2.	Gauge	Check Operation		
3.	Cutter Teeth	Check	Replace if damaged.	
4.	Steering	Check Line & Grade		
5.	Conveyor Lift	Lubricate (7 places)	Lubricate until grease is forced out.	Mobil XHP222
6.	Closed Face	Lubricate	Lubricate until grease is forced out.	Mobil XHP222
7.	Steering Cylinder	Lubricate (2 per cyl)	Lubricate until grease is forced out.	Mobil XHP222
8.	Dirt Wing Pins	Lubricate (2 per cyl)	Lubricate until grease is forced out.	Mobil XHP222
9.	Return Filter	Check (3 Filters)	Replace filter(s) per indicator.	Filter Element
*10.	Hoses/Pwr Cables	Inspect	Replace if cracks/wear visible.	
*11.	Decals	Inspect	Must be legible. Replace as needed.	
*12.	Haul Unit, Pump Unit & Jack Frame	Perform Maintenance	Refer to your machine's maintenance manual.	

\* Not Shown

Periodic Maintenance - TBM - Daily Or Every 10 Hours Of Operation Or Shift Change

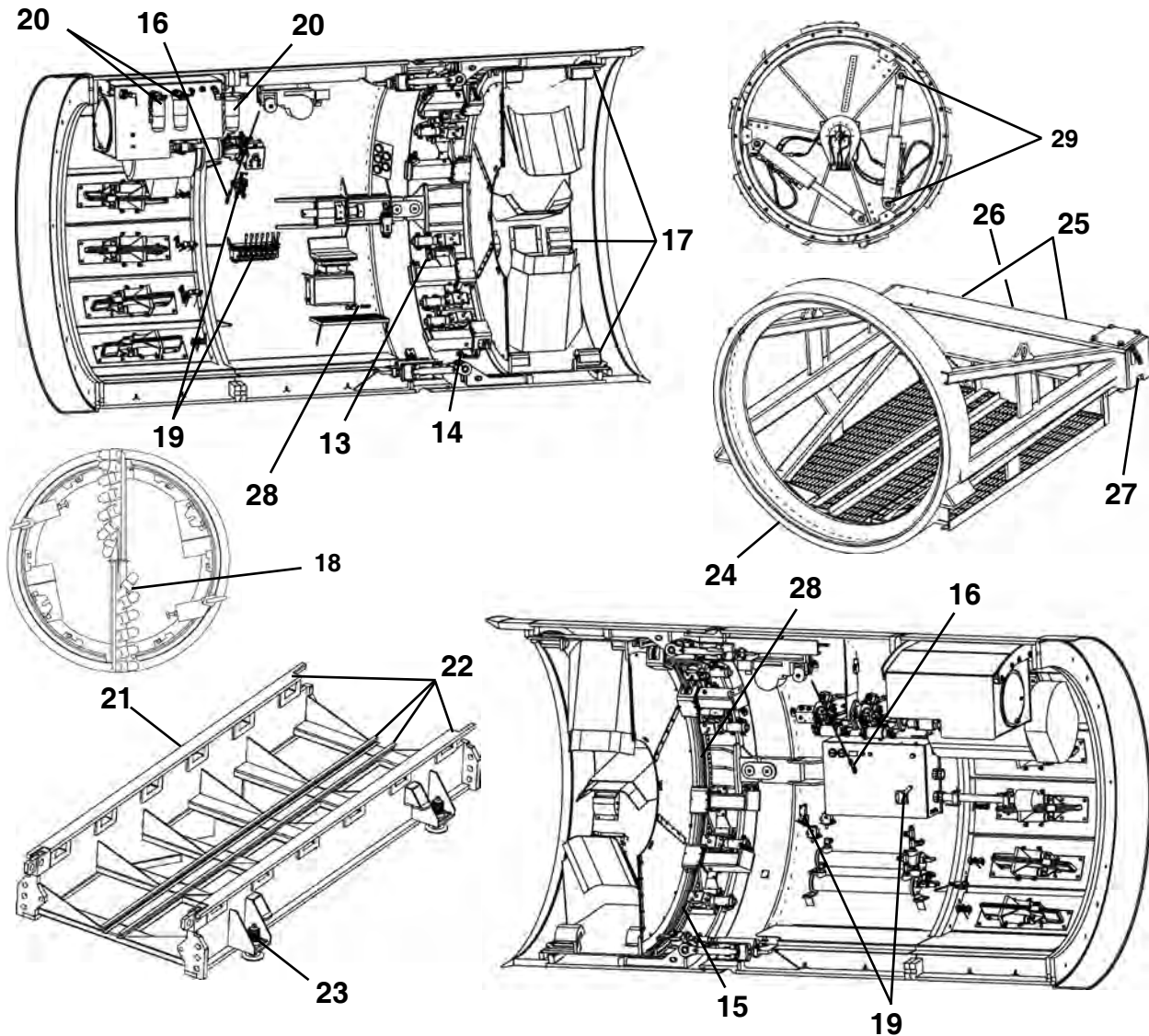

**DAILY OR EVERY 10 HOURS OF OPERATION OR SHIFT CHANGE**

ITEM	COMPONENT	SERVICE	REQUIREMENT	MATERIAL
13.	Thrust Roller	Lubricate	Lubricate until grease is forced out.	Mobil XHP222
14.	Idler Roller	Lubricate	Lubricate until grease is forced out.	Mobil XHP222
15.	Drive Gear Roller & Bolts	Inspect	Roller spools must rotate freely & replace bolts/rollers when worn > 1/8"	
16.	Conveyor Lift Cable	Inspect	Replace at first sign of wear or damage.	
17.	Drum Roller	Lubricate	Lubricate until grease is forced out.	Mobil XHP222
18.	Cutter Bar & Teeth	Inspect & Adjust	Adjust over cut and replace worn or damaged teeth.	
19.	Controls	Check For Proper Operation		
20.	Return Filter	Check	Replace filter(s) per indicator.	Filter Element
21.	Skid Base	Inspect	If damaged, repair or replace.	
22.	Rails	Inspect	If damaged, repair or replace.	
23.	Leveling Screws	Lubricate	Lubricate generously.	Mobil XHP222
24.	Yoke Frame	Inspect	If damaged, repair or replace.	
25.	Ram Retaining Pins	Inspect	If damaged, repair or replace.	
26.	Retaining Pin Stop	Inspect	If damaged, repair or replace.	
27.	Yoke Wheels	Lubricate	Lubricate until grease is forced out.	Mobil XHP222
28.	Gear Ring	Lubricate	Maintain lubrication to gear ring.	
29.	Closed Face	Lubricate	Lubricate until grease is forced out.	Mobil XHP222
*30.	Hoses/Pwr Cables	Inspect	Replace if damaged before operating.	

\* Not Shown

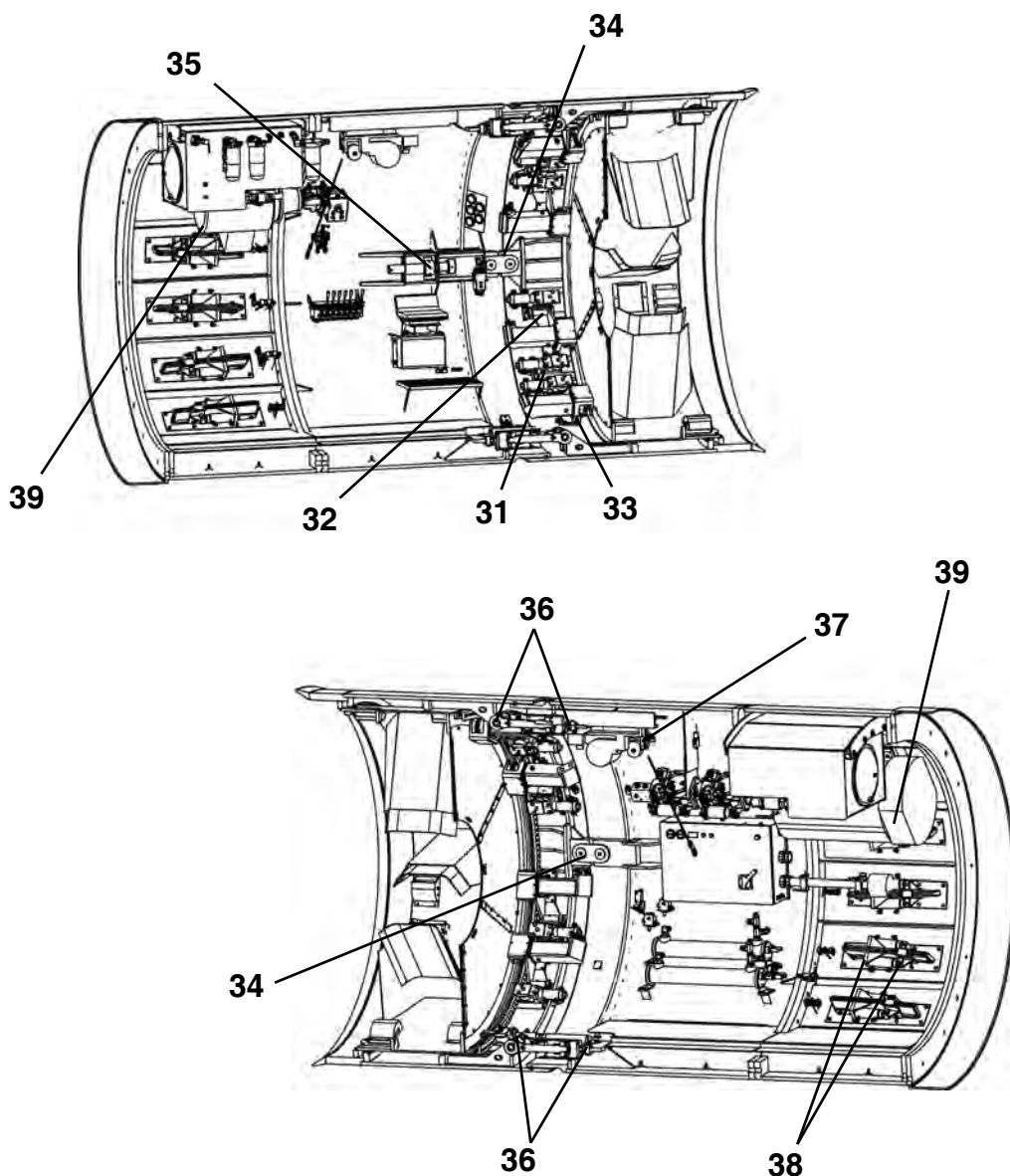

**WEEKLY OR EVERY 50 HOURS OF OPERATION**

ITEM	COMPONENT	SERVICE	REQUIREMENT	MATERIAL
31.	Thrust Bracket Guides & Cyl Pin	Lubricate and check pin for damage.	Lubricate until grease is forced out.	Mobil XHP222
32.	Motor Bracket Pivot Pin	Lubricate	Lubricate until grease is forced out.	Mobil XHP222
33.	Drive Motor To Gear	Check Clearance	1/16" to 1/8" max. clearance	
34.	Steering Link	Check for elongation.	Replace if > 3/16".	
35.	Steering Link	Lubricate nut & threads.	Lubricate thoroughly.	Anti seize lube
36.	Steering Cylinder	Lubricate	Lubricate until grease is forced out.	Mobil XHP222
37.	Conveyor Lift	Lubricate	Lubricate until grease is forced out.	Mobil XHP222
38.	Dirt Wing Pins	Lubricate	Lubricate until grease is forced out.	Mobil XHP222
39.	Motors	Check	Ventilation openings clean and drain holes open.	

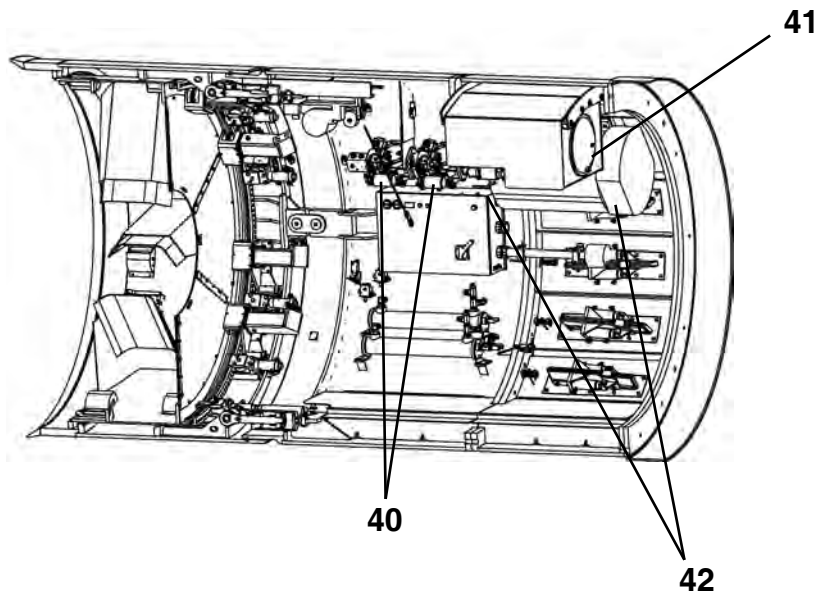
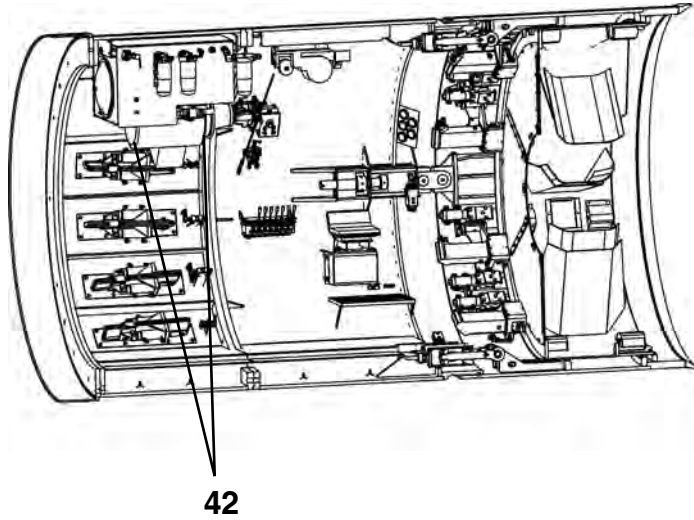

**EVERY 500 HOURS OF OPERATION**

ITEM	COMPONENT	SERVICE	REQUIREMENT	MATERIAL
40.	BH Pump Filter	Replace (2 Places)	Replace with new.	Filter

**EVERY 1000 HOURS OF OPERATION**

ITEM	COMPONENT	SERVICE	REQUIREMENT	MATERIAL
41.	Hydraulic Reservoir	Drain and replace	Drain and fill with new oil.	ISO-VG-68-20W

**ANNUALLY**

ITEM	COMPONENT	SERVICE	REQUIREMENT	MATERIAL
42.	Electric Motor Brgs.	Lubricate (2 per motor)	2 Shots	Mobil Polyrex EM

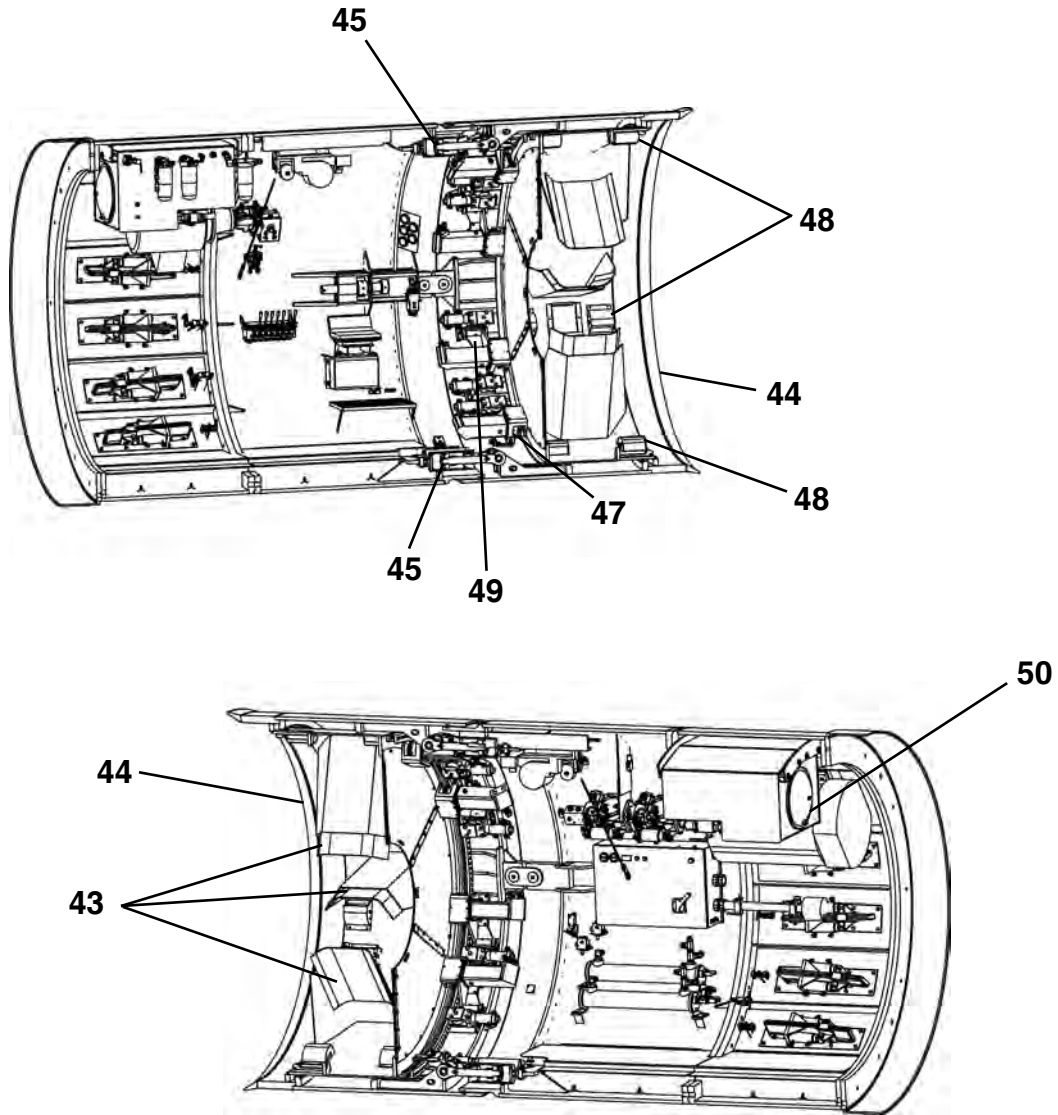

**AFTER EACH DRIVE**

ITEM	COMPONENT	SERVICE	REQUIREMENT	MATERIAL
43.	Dirt Paddles	Inspect	Replace if damaged.	
44.	Cutter Ring	Inspect For Damage		
45.	Steering Cylinders	Inspect	If damaged, repair or replace.	
*46.	Lifting Eye	Inspect	Repair if damaged before lifting.	
47.	Motor Sprocket	Inspect	Replace when flat is < 3/8".	
48.	Drum Roller	Inspect	If worn, replace. Bearing spins freely, no play.	
49.	Motor Bracket	Inspect & Tighten Bolts	If damaged, repair or replace.	
50.	Hydraulic Reservoir	Drain Water	Drain until water is removed.	

\* Not Shown

## PRIOR TO EACH JOB LAUNCH

### 1. CHECK CONTROL OPERATION

Before launching TBM, be sure to check all TBM, Pump Unit/jacking frame, haul unit controls and other supporting equipment for proper operation. If controls do not function properly, repair or replace BEFORE operation.

CHECK THE FOLLOWING CONTROLS FOR PROPER OPERATION:

ALL E-Stops, and gas detectors:  
check for proper operation

Conveyor Controls:  
conveyor lift - up and down  
conveyor drive - forward and reverse  
conveyor safety switch - MUST stop  
cutterhead rotation

Inner Drum Controls:  
inner drum advance cylinder - extend and retract

Boring Head Controls:  
cutterhead rotation - CW and CCW rotation

Steering Controls:  
steering cylinder - extend and retract

Dirt Wing Controls  
cylinder control - extend and retract

Auxiliary or Closed Face Controls  
check control operation

Pump Unit Controls

Haul Unit Controls

Jacking Frame/IJS Controls

Lights

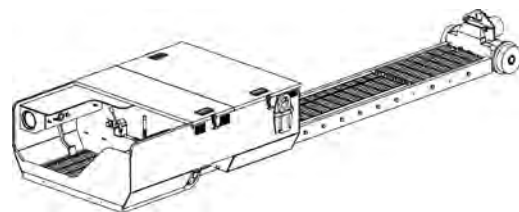
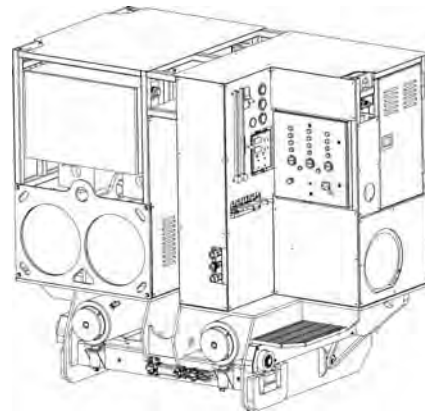
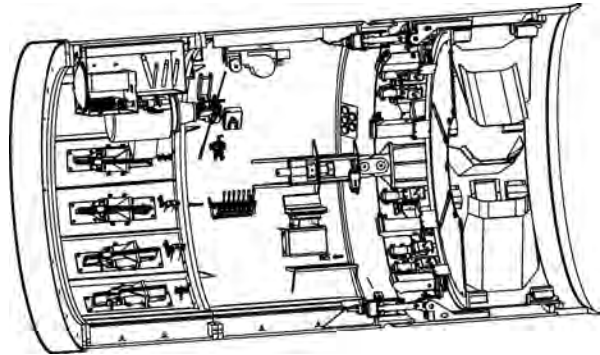

## 2. CHECK GAUGE OPERATION

Check system pressures for proper operation.  
If systems are not functioning properly, repair or replace system components BEFORE operation.

TBM

Auxiliary pressure (A) ..... 2,800 - 3,000 psi  
Boring head (CW) pressure (B)...2,800 - 3,000 psi  
Boring head (CCW) pressure (C)..2,800 - 3,000 psi  
Steering pressure\* (D/E) ..... 2,800 - 3,000 psi

\* The maximum steering cylinder pressure to make steering corrections is 3,000 psi. The Steering PSI gauges show the active pressure in the cylinders.  
**IMPORTANT: DURING TBM ADVANCEMENT, DO NOT ALLOW STEERING CYLINDER PRESSURES TO EXCEED 3,000 PSI. DOING SO WILL CAUSE HYDRAULIC COMPONENT & STRUCTURAL DAMAGE.**

5000 Pump Unit/Jacking Frame

Refer to your operation manual for proper system pressures.

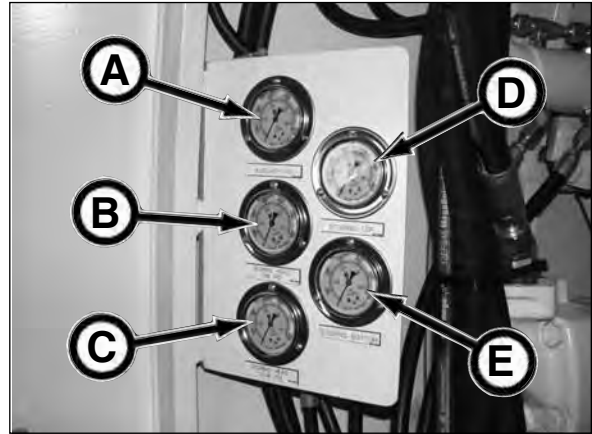

## 3. CHECK CUTTER TEETH

Check all cutter teeth. Repair or replace as necessary.

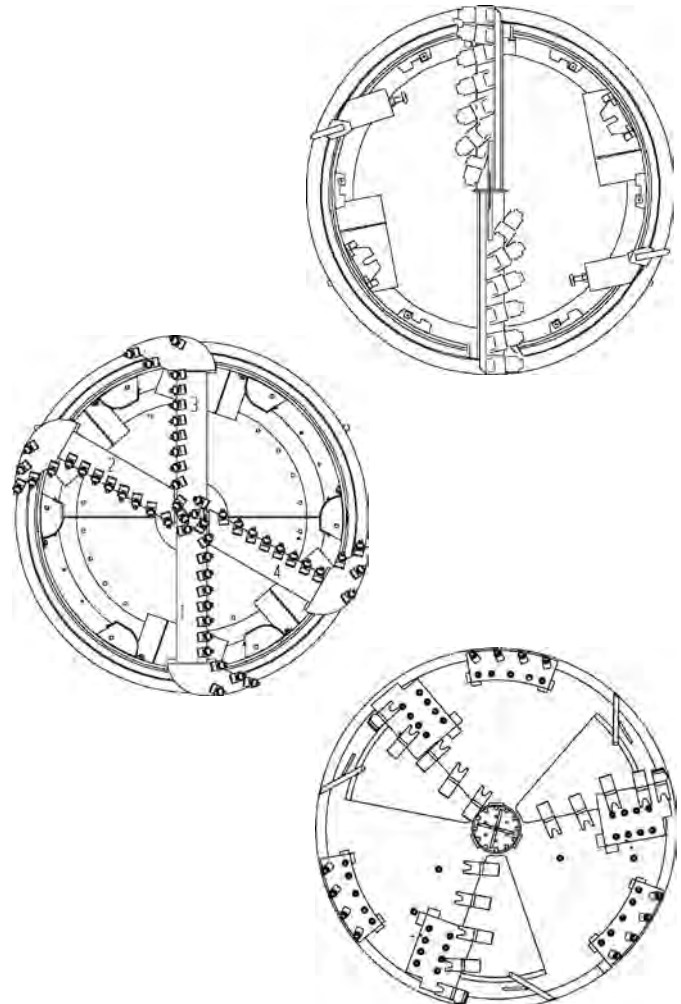

#### 4. CHECK LINE & GRADE

Check line and grade before launching. Adjust as needed using the steering cylinders and steering adjustment assembly.

Be sure to check line and grade alignment often, with and without forward thrust applied. Keep in mind if you are off one degree, the bore will be off nearly two feet per one hundred feet.



#### 5. LUBRICATE CONVEYOR LIFT

Lubricate conveyor lift with Mobilgrease® XHP222 or equivalent until grease is forced out.

- Trolley bracket pins (A) - 4 places
- Cable pulley bearing (B) - 2 places
- Adjustment pin (C) - 1 place

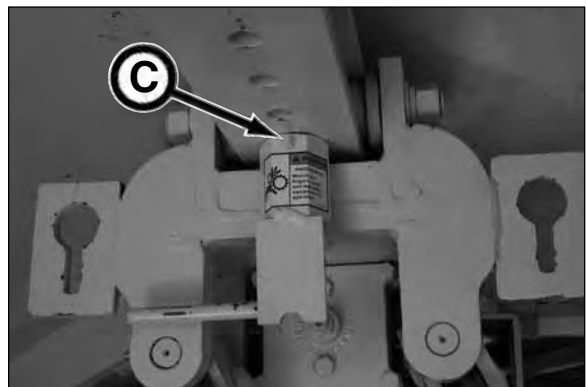
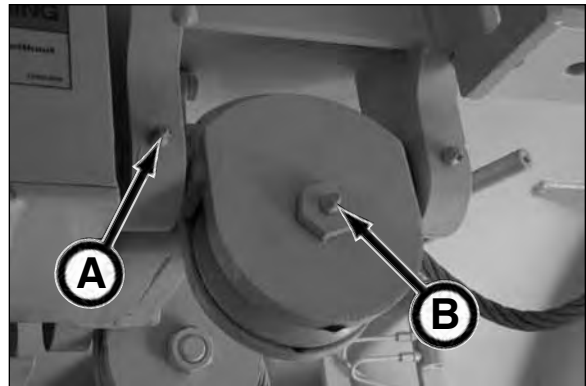

## 6. LUBRICATE CLOSED FACE CYLINDERS & DOORS (IF EQUIPPED)

Lubricate closed face doors (A) with Mobilgrease® XHP222 or equivalent until grease is forced out.

Lubricate closed face cylinders (B) with Mobilgrease® XHP222 or equivalent until grease is forced out.

The number of cylinders vary depending upon the size of the TBM.

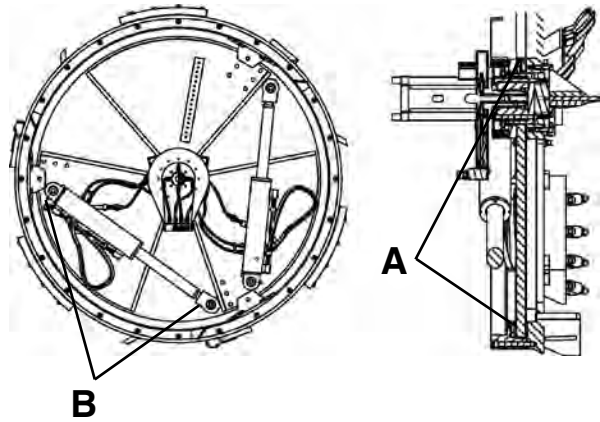

## 7. LUBRICATE STEERING CYLINDERS

Lubricate steering cylinders (C) with Mobilgrease® XHP222 Premium Lubricating Grease or equivalent until grease is forced out.

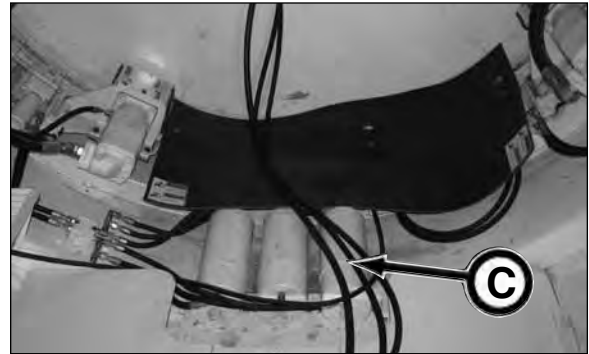

*Bottom Steering Cylinders*

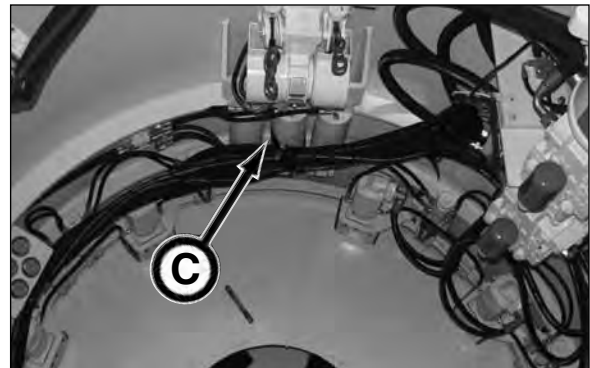

*Top Steering Cylinders*

## 8. LUBRICATE DIRT WING PINS

Lubricate all dirt wing pins (D) with Mobilgrease® XHP222 Premium Lubricating Grease or equivalent until grease is forced out.

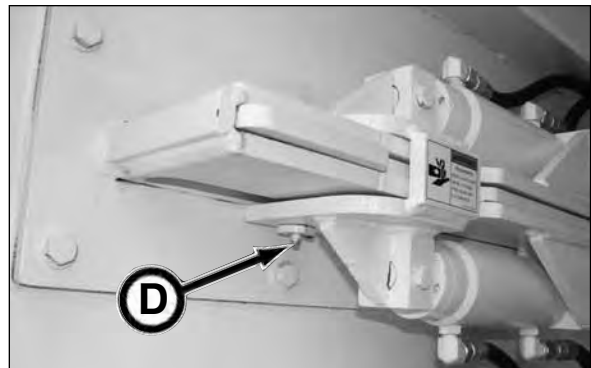

## 9. CHECK RETURN FILTER INDICATORS

The auxiliary (A), boring head 1 (B) and boring head 2 (C) return filters on your TBM, filter the oil from the boring head and auxiliary pumps going back into the hydraulic reservoir.

To prevent under or over servicing of the hydraulic filter elements, a filter indicator has been installed for each filter assembly.

The green OK zone indicates that the filter is functioning properly.

The yellow zone indicates that the filter will soon require replacement.

Replace filter when the indicator needle on the gauge is in the red CHANGE zone.

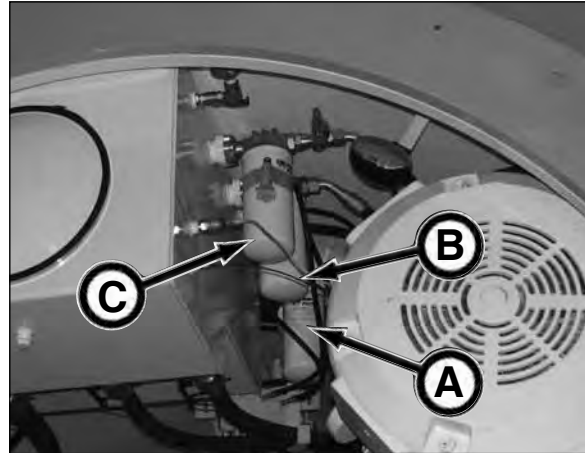

### NOTICE

The indicator needle may display in the red CHANGE zone at initial start-up until the oil reaches normal operating temperature. If the indicator needle continues to display in the red CHANGE zone after reaching normal operating temperature, replace filter to prevent contamination.

Return Filter Indicators:

- Auxiliary Return Filter Indicator (D)
- Boring Head 1 Return Filter Indicator (E)
- Boring Head 2 Return Filter Indicator (F)

All filters require replacement if any of the following situations occur:

- A major component fails.
- Any sign of water contamination from an oil analysis or if oil is milky or foaming.
- A hydraulic oil sample indicates large particle contamination.

1. With power LOCKED OUT, clean and dry area around filter(s).

2. Remove filter. Dispose of filter properly.

### NOTICE

Remove filter gasket if stuck in filter housing.

3. Fill new filter with clean hydraulic oil.

4. Lubricate new filter gasket with a light coating of clean hydraulic oil.

5. Install new filter. Hand tighten only. Follow instructions on filter.

6. Check for leaks.

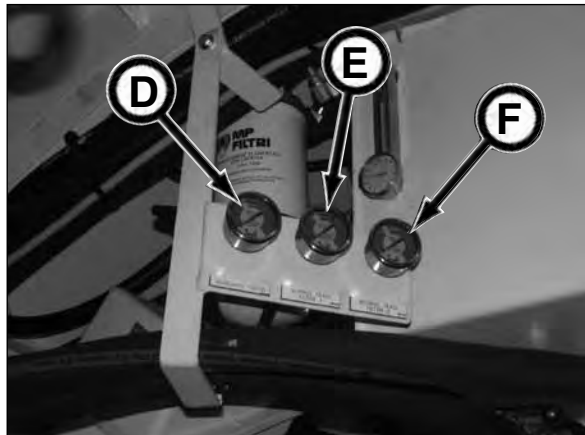

### 10. INSPECT HYDRAULIC HOSES & POWER CABLES

Inspect ALL hydraulic hoses and power cables for cracks, wear or damage. Repair or replace BEFORE operation.

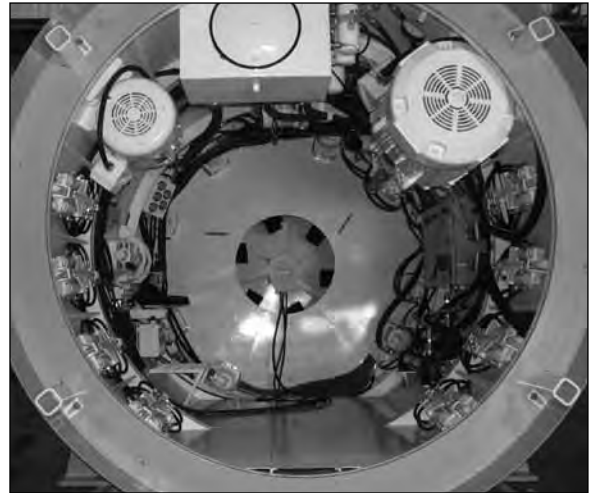

### 11. INSPECT DECALS

Inspect ALL decals, operational and safety decals to be sure they are clean and readable.

Use soft cloth, water, and a mild soap to clean the decals if they are too dirty to read. DO NOT clean safety decals with solvent. Solvent will damage decals. Replace decals immediately if they are damaged, missing, or hard to read.

Before applying a new decal, be sure the surface is clean and dry.



### 12. PERFORM MAINTENANCE ON ALL SUPPORTING EQUIPMENT

Be sure all TBM supporting equipment such as the haul unit, pump unit, jacking frame, and generator are properly maintained and are operating properly. Be sure to repair or replace equipment before operating TBM. Refer to the operation and maintenance manuals of the equipment.

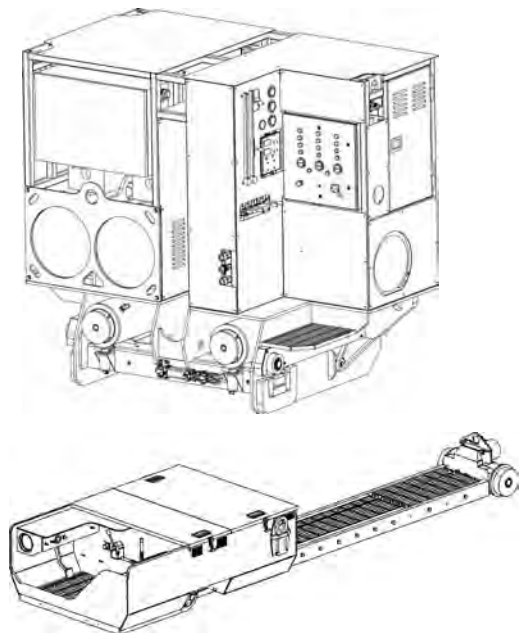

## DAILY OR EVERY 10 HOURS OF OPERATION OR SHIFT CHANGE

### 13. LUBRICATE THRUST ROLLERS

Lubricate all thrust rollers (A) with Mobilgrease® XHP222 or equivalent until grease is forced out.

The rollers should be lubricated more often if subjected to wet conditions.

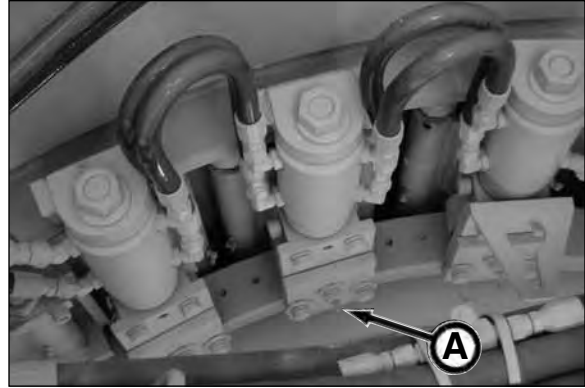

### 14. LUBRICATE IDLER ROLLERS

Lubricate idler rollers (B) with Mobilgrease® XHP222 or equivalent until grease is forced out.

The rollers should be lubricated more often if subjected to wet conditions.

The number of idler rollers vary depending upon the size of the TBM.

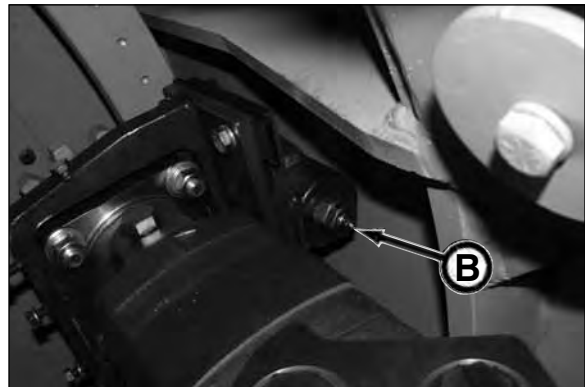

### 15. INSPECT DRIVE GEAR ROLLER & HARDWARE

Inspect drive gear bolts and nuts (C) for damage. Replace if worn or damaged.

Check that roller spools (D) rotate freely. If not replace roller.

If roller spools are worn more than 1/8" (3 mm), the spools and bolts/nuts must be replaced.

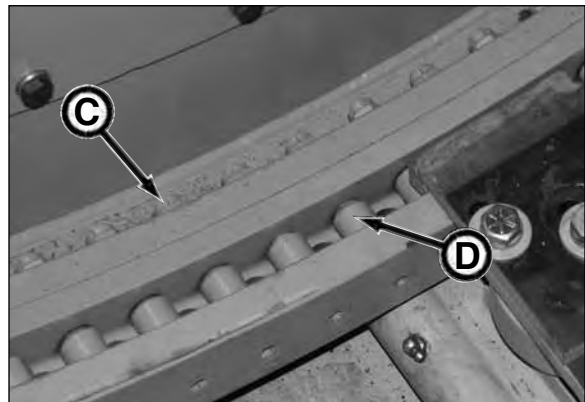

### 16. INSPECT CONVEYOR LIFT CABLES

Inspect conveyor lift cables, hooks, protective sleeves and cable clamps (E) for wear or damage.

Replace cables, hooks, protective sleeves and cable connectors as a set at the first sign of wear or damage.

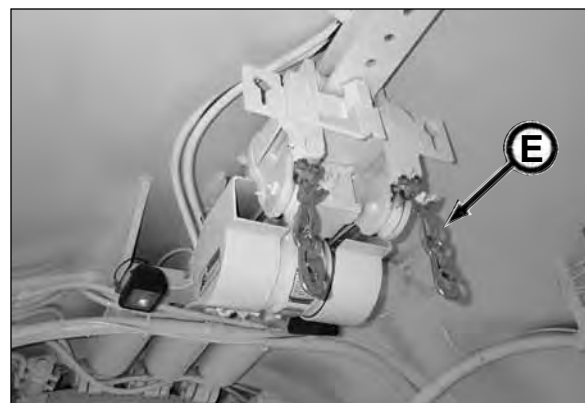

### 17. LUBRICATE DRUM ROLLERS

Lubricate drum rollers (A) with Mobilgrease® XHP222 or equivalent until grease is forced out.

The rollers should be lubricated more often if subjected to wet conditions.

The number of drum rollers vary depending upon the size of the TBM.

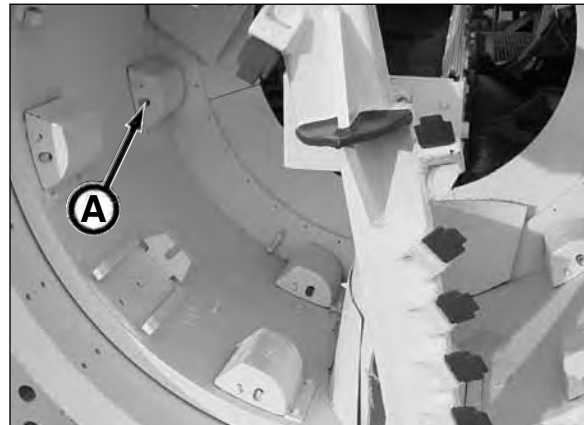

### 18. INSPECT CUTTER BAR & TEETH

Inspect cutter bar and teeth for wear or damage. Repair or replace as needed.

Check overcut (dirt cutter only) and adjust accordingly as described below.

The typical overcut is 1.50" which allows space for steering and the addition of bentonite. Keep in mind that too large of an overcut can lead to uncontrollable steering.

1. Loosen nut (B), set screw (C), and nut (D).
2. Readjust bolt (E) to move cutter (F) to desired overcut.
3. Retighten nut (D).
4. Retighten set screw (C).
5. Retighten nut (B).

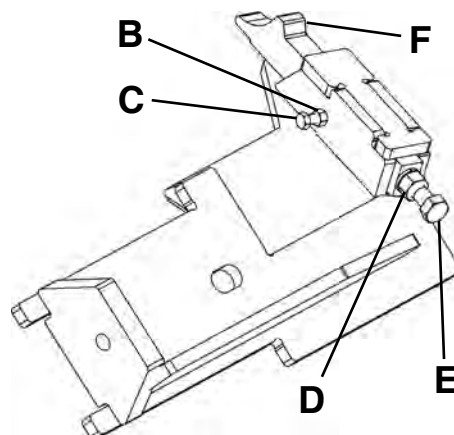

## 19. CHECK CONTROL OPERATION

Before operating TBM or at each shift change, be sure to check all TBM, Pump Unit, haul unit controls and other supporting equipment for proper operation. If controls do not function properly, repair or replace BEFORE operation.

CHECK THE FOLLOWING CONTROLS FOR PROPER OPERATION:

ALL E-Stops, and gas detectors:  
check for proper operation

Conveyor Controls:  
conveyor lift - up and down  
conveyor drive - forward and reverse  
conveyor safety switch - MUST stop  
cutterhead rotation

Inner Drum Controls:  
inner drum advance cylinder - extend and retract

Boring Head Controls:  
cutterhead rotation - CW and CCW rotation

Steering Controls:  
steering cylinder - extend and retract

Dirt Wing Controls  
cylinder control - extend and retract

Auxiliary or Closed Face Controls  
check control operation

Pump Unit Controls

Haul Unit Controls

Jacking Frame/IJS Controls

Lights

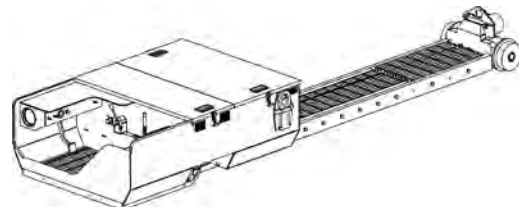
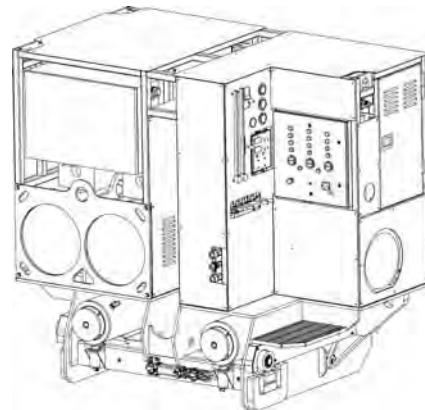
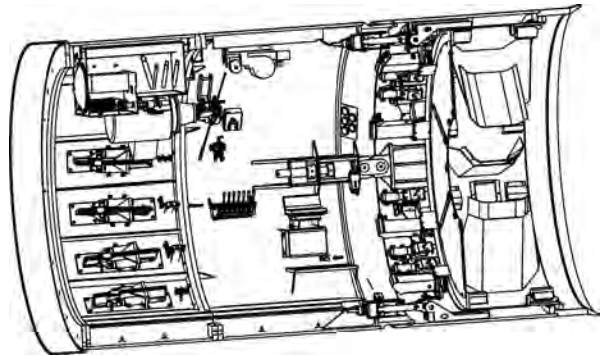

## 20. CHECK RETURN FILTER INDICATORS

The auxiliary (A), boring head 1 (B) and boring head 2 (C) return filters on your TBM, filter the oil from the boring head and auxiliary pumps going back into the hydraulic reservoir.

To prevent under or over servicing of the hydraulic filter elements, a filter indicator has been installed for each filter assembly.

The green OK zone indicates that the filter is functioning properly.

The yellow zone indicates that the filter will soon require replacement.

Replace filter when the indicator needle on the gauge is in the red CHANGE zone.

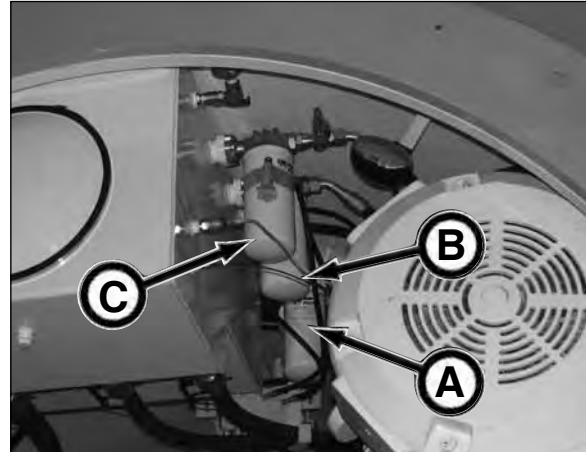

### NOTICE

The indicator needle may display in the red CHANGE zone at initial start-up until the oil reaches normal operating temperature. If the indicator needle continues to display in the red CHANGE zone after reaching normal operating temperature, replace filter to prevent contamination.

Return Filter Indicators:

- Auxiliary Return Filter Indicator (D)
- Boring Head 1 Return Filter Indicator (E)
- Boring Head 2 Return Filter Indicator (F)

All filters require replacement if any of the following situations occur:

- A major component fails.
- Any sign of water contamination from an oil analysis or if oil is milky or foaming.
- A hydraulic oil sample indicates large particle contamination.

1. With power LOCKED OUT, clean and dry area around filter(s).

2. Remove filter. Dispose of filter properly.

### NOTICE

Remove filter gasket if stuck in filter housing.

3. Fill new filter with clean hydraulic oil.

4. Lubricate new filter gasket with a light coating of clean hydraulic oil.

5. Install new filter. Hand tighten only. Follow instructions on filter.

6. Check for leaks.

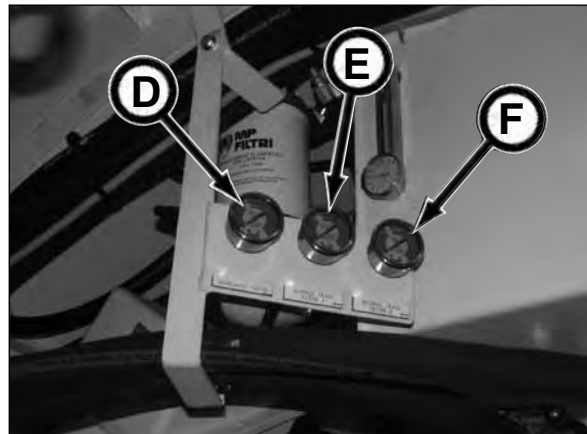

## 21. INSPECT SKID BASE

Visually inspect skid base for cracks or other damage. Also check for damaged, loose, or missing hardware. Replace with new.

If cracks or damage are present, contact your Akkerman Aftermarket Support representative for authorized repair or replacement procedures.

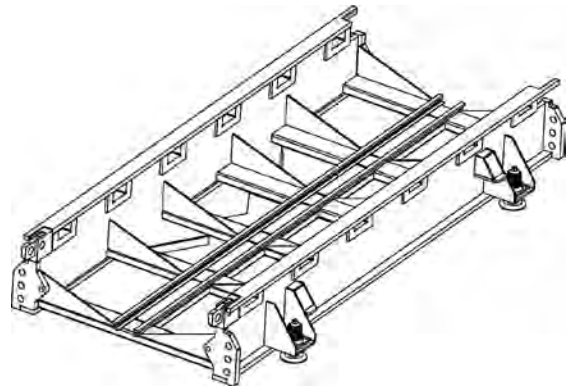

## 22. INSPECT RAILS

Clean and inspect rails (A) for cracks or other damage.

If cracks or damage are present, contact your Akkerman Aftermarket Support representative for authorized repair or replacement procedures.

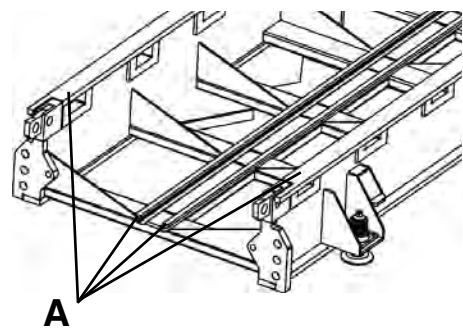

## 23. LUBRICATE LEVELING SCREWS

Lubricate leveling screws (B) with Mobilgrease® XHP222 Premium Lubricating Grease or equivalent.

Lubricate threads thoroughly.

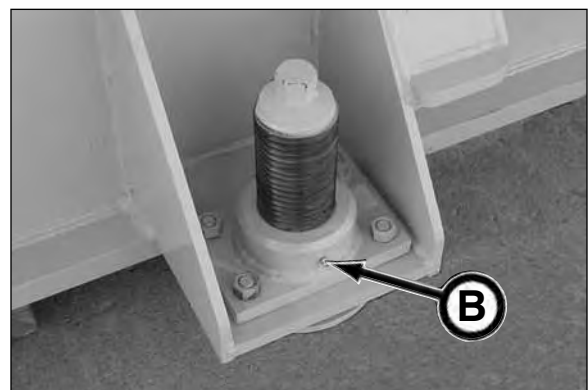

## 24. INSPECT YOKE FRAME

Visually inspect yoke for cracks or other damage. Also check for damaged, loose, or missing hardware. Replace with new.

If cracks or damage are present, contact your Akkerman Aftermarket Support representative for authorized repair or replacement procedures.

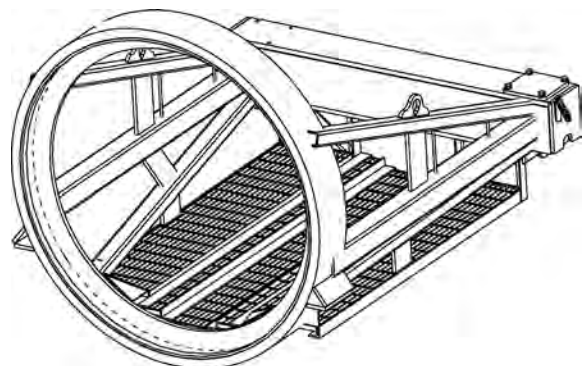

### 25. INSPECT RAM RETAINING PINS

Visually inspect retaining pins (A) (2 places) for damage.

If damage is present, replace with new.

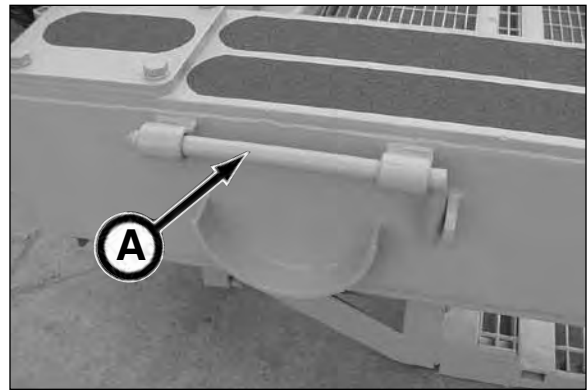

### 26. INSPECT RAM RETAINING PIN STOP

Visually inspect stop (B) or hardware for damage.

If damaged or missing, replace with new.

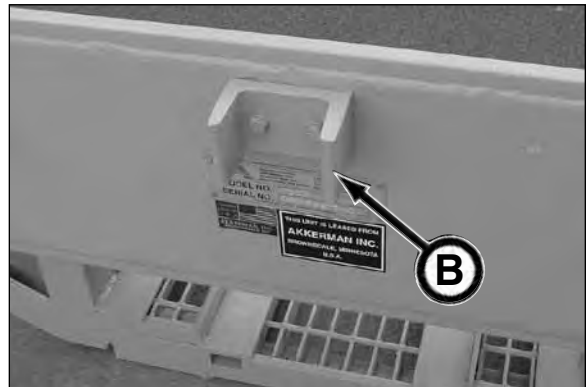

### 27. LUBRICATE YOKE WHEELS

Lubricate yoke wheels (C) with Mobilgrease® XHP222 Premium Lubricating Grease or equivalent.

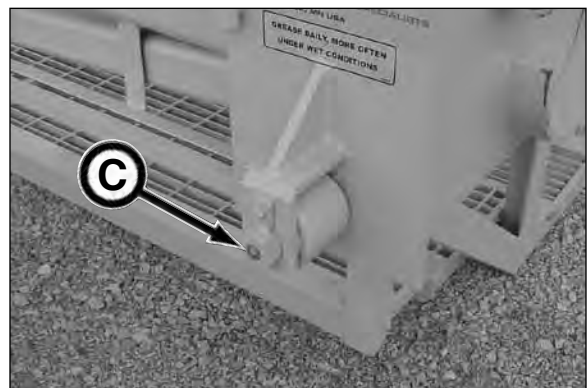

## 28. LUBRICATE GEAR RING

Lubricate gear ring by opening gear ring oiler valve (A) to lubricate the drive gear ring during operation. Be sure gear ring is being lubricated during operation. Failure to do so will cause premature wear/failure to drive gear.

Use the shutoff valve (B) to open and close oil flow from tank (C).

Adjust gear ring oiler as follows:

CW - decreases oil flow

CCW - increase oil flow

Adjust gear ring oiler so the drive gear/rollers are lightly lubricated with oil. Typically a slow drip is sufficient.

Close shutoff valve during pipe change or other pause in tunneling otherwise the drive gear will be over lubricated.

Periodically check gear ring oil tank level. Refill as necessary. Use oil for lubrication. **DO NOT USE GREASE!**

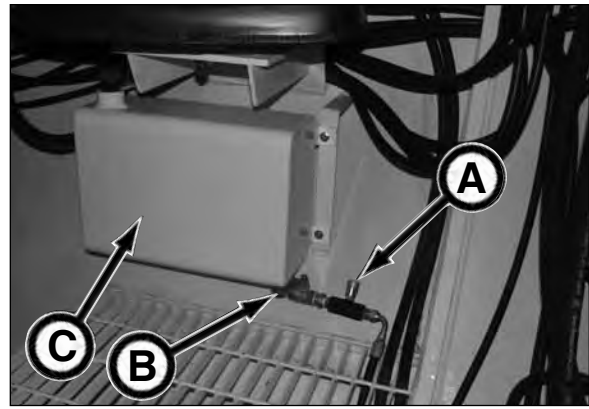

## 29. LUBRICATE CLOSED FACE CYLINDERS & DOORS (IF EQUIPPED)

Lubricate closed face doors (D) with Mobilgrease® XHP222 or equivalent until grease is forced out.

Lubricate closed face cylinders (E) with Mobilgrease® XHP222 or equivalent until grease is forced out.

The number of cylinders vary depending upon the size of the TBM.

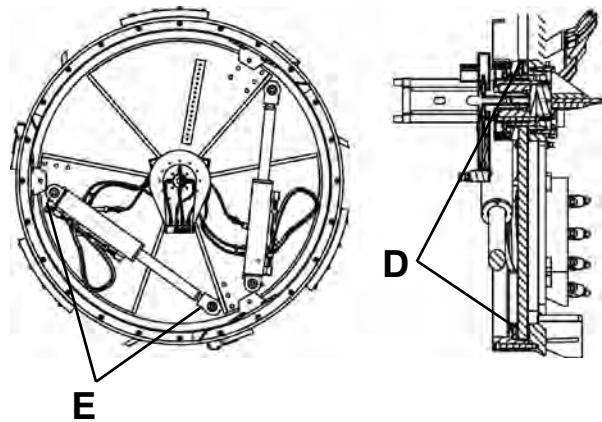

## 30. INSPECT HYDRAULIC HOSES & POWER CABLES

Inspect ALL hydraulic hoses and power cables for wear or damage. Repair or replace BEFORE operation.

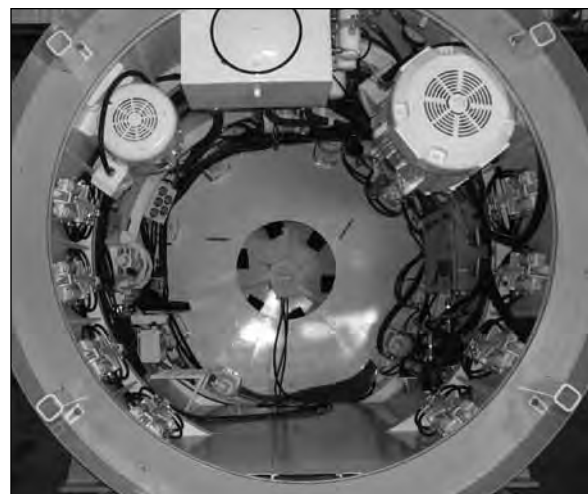

## WEEKLY OR EVERY 50 HOURS OF OPERATION

### 31. LUBRICATE THRUST BRACKET GUIDES & CYLINDER PIN

Lubricate thrust bracket guides (A) with Mobilgrease® XHP222 Premium Lubricating Grease or equivalent until grease is forced out.

Check cylinder pins (B) for wear or damage. Repair or replace before operating.

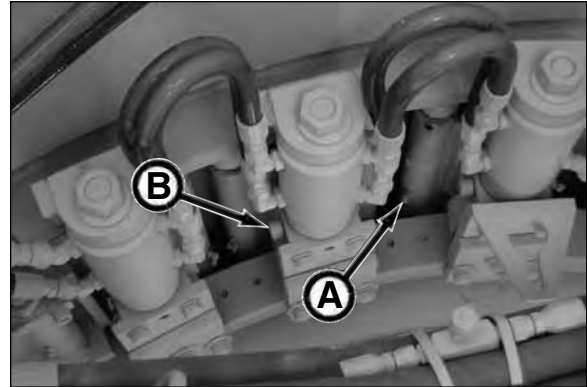

### 32. LUBRICATE MOTOR BRACKET PIVOT PIN

Lubricate pivot pin (C) with Mobilgrease® XHP222 Premium Lubricating Grease or equivalent until grease is forced out.

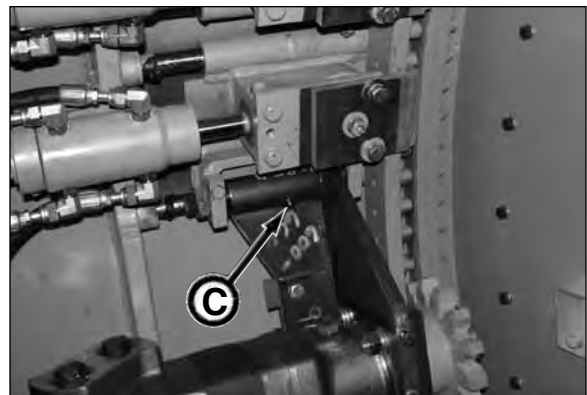

### 33. CHECK DRIVE MOTOR TO GEAR RING CLEARANCE (BACKLASH)

Check clearance (play or backlash) between drive motor assembly and gear ring. The clearance should be 1/16" - 1/8" (1.5 - 3 mm).

Check clearance by pushing drive motor. If there is not enough clearance (1/16" - 1/8" [1.5 - 3 mm]), use shims (D) as needed. If the clearance cannot be achieved, the idler roller shaft (E) must be replaced.

If the clearance between the drive motor assembly and gear ring is too loose, premature wear will result on gear ring spools and sprocket.

If the clearance between the drive motor assembly and gear ring is too tight, premature wear will result on idler roller shaft or cause shaft failure.

Be sure to replace motor guard before operating TBM.

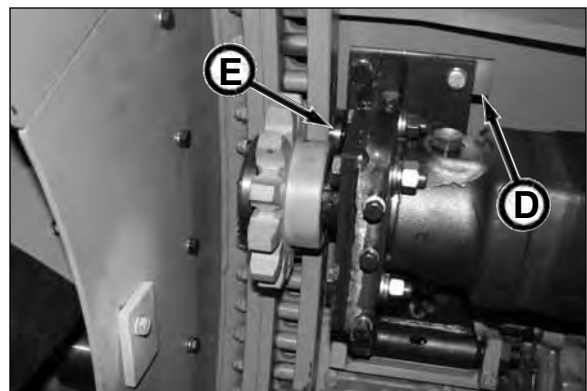

### 34. CHECK STEERING LINK FOR ELONGATION

Remove bolt and washer from steering link and check for elongation.

The maximum elongation is 3/16" (5 mm). If elongation exceeds 3/16" (5 mm), the steering link and hardware must be replaced.

If link or hardware is damaged, replace with new.

Repeat inspection on other steering link.

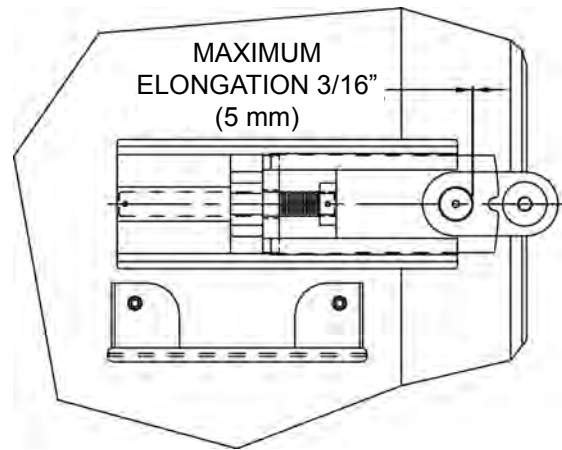

### 35. LUBRICATE STEERING LINK

Lubricate steering link nut (A) and threads (B) with anti seize lubricant.

Lubricate threads thoroughly.

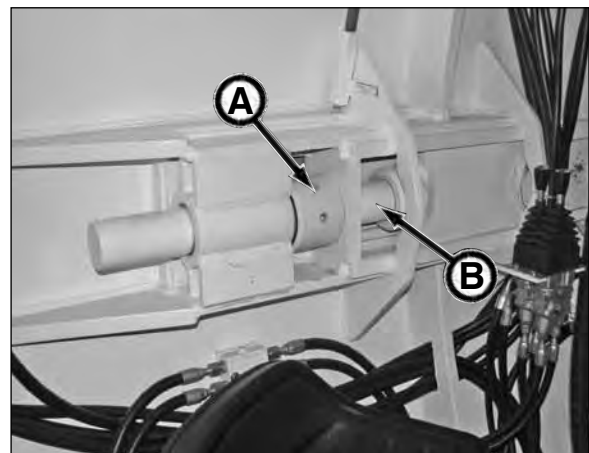

### 36. LUBRICATE STEERING CYLINDERS

Lubricate steering cylinders (C) with Mobilgrease® XHP222 Premium Lubricating Grease or equivalent until grease is forced out.

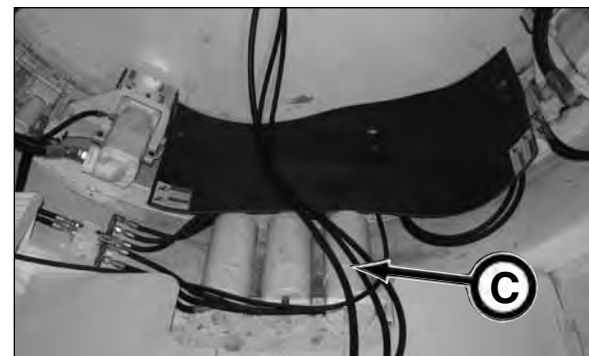

*Bottom Steering Cylinders*

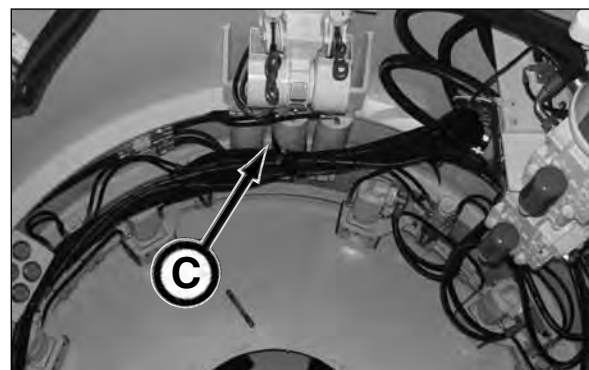

*Top Steering Cylinders*

### 37. LUBRICATE CONVEYOR LIFT

Lubricate conveyor lift with Mobilgrease® XHP222 or equivalent until grease is forced out.

- Trolley bracket pins (A) - 4 places
- Cable pulley bearing (B) - 2 places
- Adjustment pin (C) - 1 place

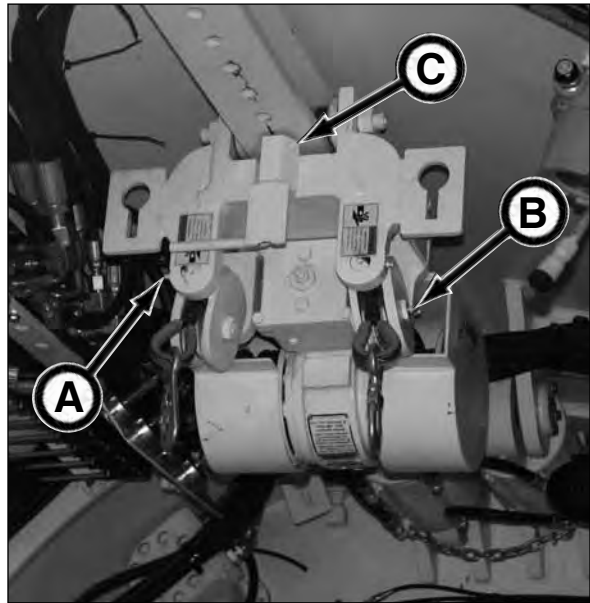

### 38. LUBRICATE DIRT WING PINS

Lubricate all dirt wing pins (D) with Mobilgrease® XHP222 Premium Lubricating Grease or equivalent until grease is forced out.

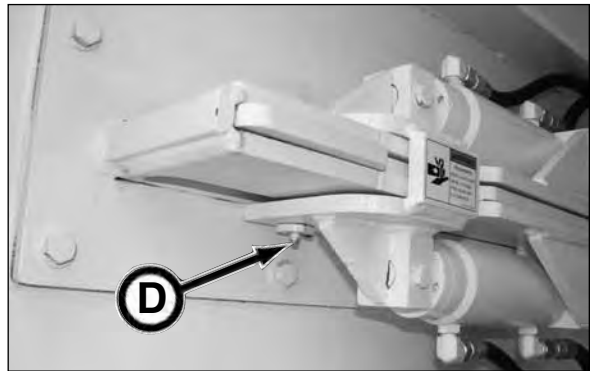

### 39. CHECK MOTORS

Inspect each motor (Boring head 200 HP motor and the auxiliary 50 HP motor) that the ventilation openings are clear to allow the free passage of air and that the drain holes are open.

Use compressed air (maximum 50 psi) to clear openings.

Grease and oil can be removed from the motors with a petroleum solvent.

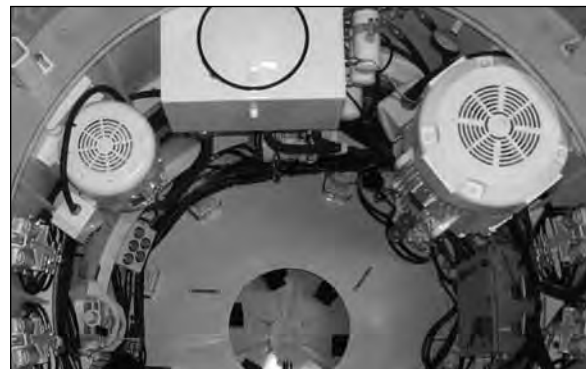

## EVERY 500 HOURS OF OPERATION

### 40. REPLACE BORING HEAD CHARGE PUMP FILTERS

Replace boring head charge pump filters (A) every 500 hours of operation or sooner if boring head system is sluggish or slow to start.

1. Move the boring head hydraulic suction ball valves (B) to the closed position.
2. Clean and dry area around charge pump filters.
3. Remove filters. Dispose of filters properly. Remove filter gasket if stuck in filter housing.
4. Lubricate new filter gasket with a light coating of clean hydraulic oil.
5. Install new filter. Hand tighten only. Follow instructions on filter.
6. Move the boring head hydraulic suction ball valves to the open position and tie strap to prevent valve closure.

**IMPORTANT: Before operating TBM, the suction valve MUST be open and tie strapped to prevent accidental closure of valve while operating. Attempting to operate the cutterhead with suction valve closed WILL damage the boring head drive pump.**

7. Check for leaks.

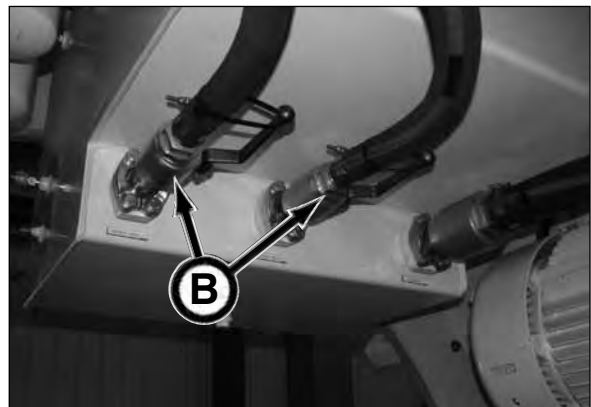
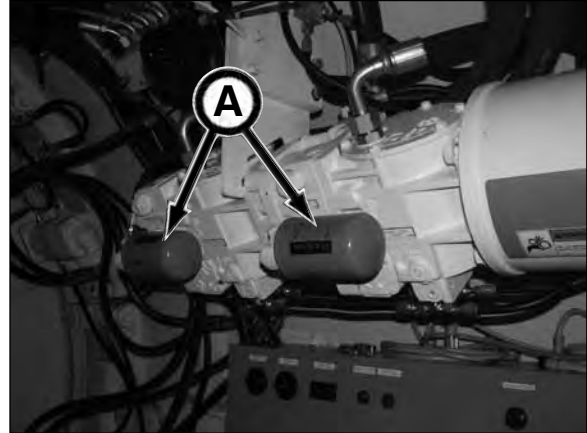

*Hydraulic Suction Valves Shown in Open, Tie Strapped Position*

## EVERY 1000 HOURS OF OPERATION

### 41. DRAIN & REPLACE HYDRAULIC OIL

Drain and replace the hydraulic oil reservoir (A) every 1000 hours or if any of the following situations occur:

- A major component fails.
- Any sign of water contamination from an oil analysis or if oil is milky or foaming.
- A hydraulic oil sample indicates large particle contamination.
- TBM becomes engulfed in water.

#### To Drain/Fill Oil Reservoir:

1. Clean and dry area around reservoir drain plug (B).
2. With a properly sized container to catch the drained oil from the reservoir, remove drain plug.
3. Once oil is drained, replace drain plug.
4. Dispose of oil properly.
5. Be sure tank breather valve (C) is open. The tank breather valve should always be open except during shipping or moving the TBM.
6. Connect male quick coupler end (D) to customer supplied fill hose end.
7. Clean area around female quick coupler (E).
8. Connect fill hose with male quick coupler to female quick coupler.
9. Start pump (customer supplied) to fill reservoir with CLEAN ISO-VG-68 20W Premium hydraulic oil or equivalent.

#### NOTICE

Refer to section 8, Lubricants for recommended hydraulic oil in certain ambient temperatures.

10. Carefully watch the tank volume on the level gauge (F) so the oil in the tank will not overflow. The reservoir capacity is 75 gal. (284 L).
11. Once reservoir is filled, remove fill pump hose with male quick coupler.

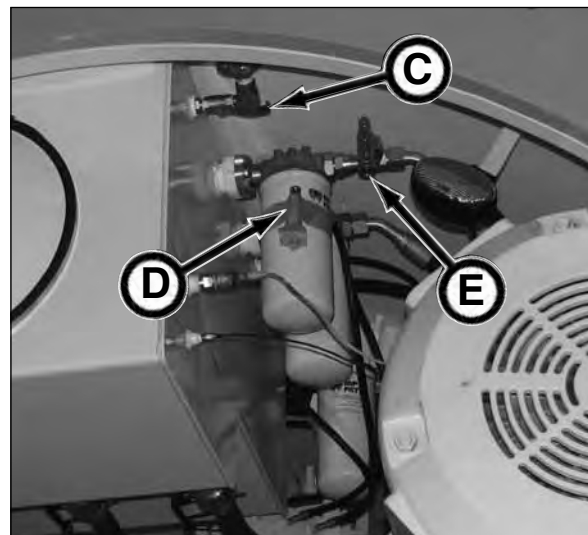
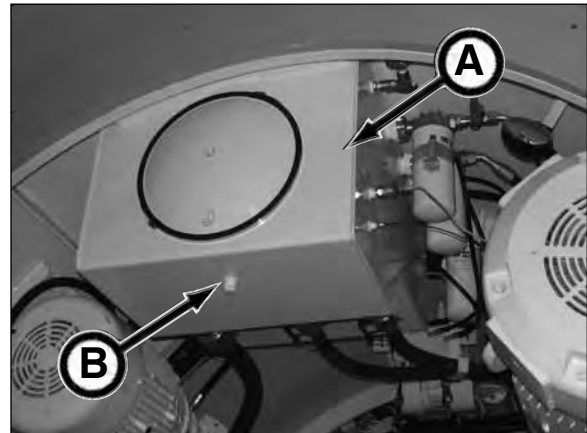

## ANNUALLY

### 42. LUBRICATE MOTOR BEARINGS

**NOTICE** For additional electric motor maintenance information, refer to the motor operation and maintenance manual.

Lubricate the electric motor bearings (A) with two shots of Mobil Polyrex® EM grease or equivalent (refer to nameplate on motor). There are two lubrication fittings on each of the boring head and auxiliary motors.

When adding lubricant, keep dirt out of the lubrication area. Wipe the fitting completely clean and use clean greasing equipment.

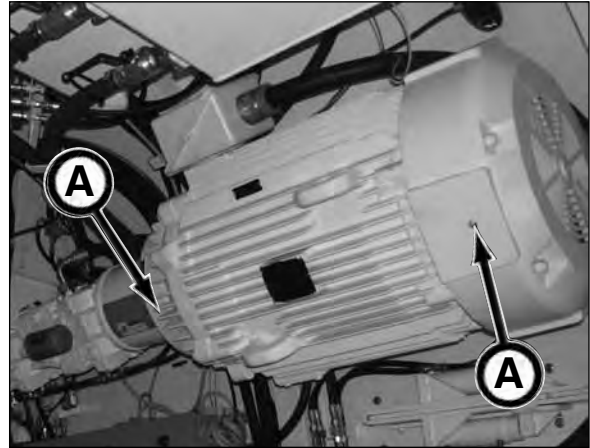

*Boring Head Electric Motor*

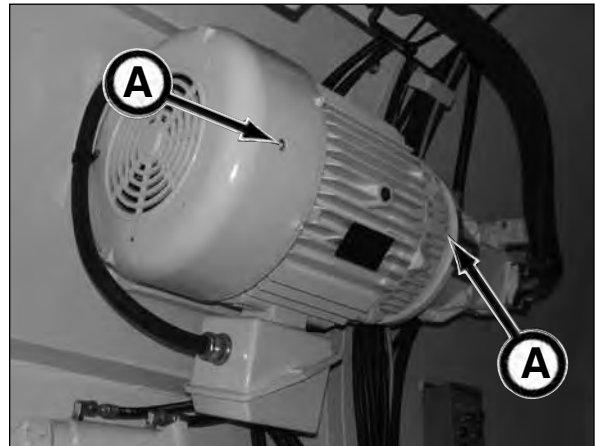

*Auxiliary Electric Motor*

## AFTER EACH DRIVE

### 43. INSPECT DIRT PADDLES

Inspect dirt paddles (A) for wear or damage. Replace dirt paddles as needed.

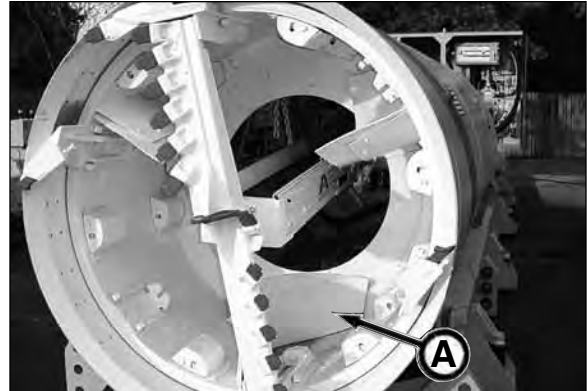

### 44. INSPECT CUTTER RING

Inspect cutter ring edge (A) for wear or damage. Cutter ring should not be dented, bent or flat. Repair as needed.

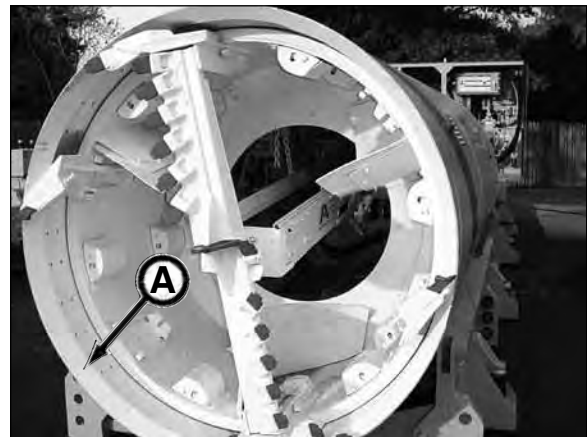

### 45. INSPECT STEERING CYLINDERS

Inspect steering cylinders (B) for wear or damage. Repair or replace before operating.

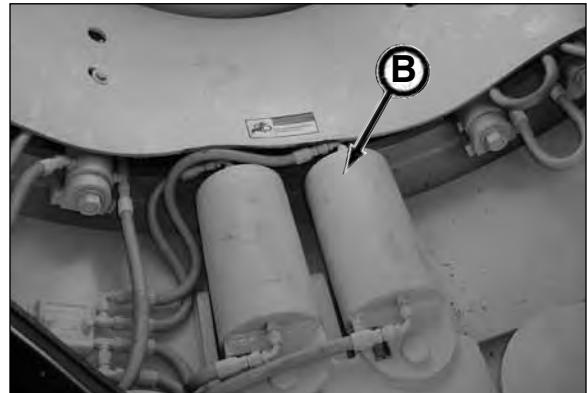

### 46. INSPECT LIFTING EYES

Inspect lifting eyes (C) for wear or damage. Worn or damaged lifting eyes MUST be replaced before lifting.

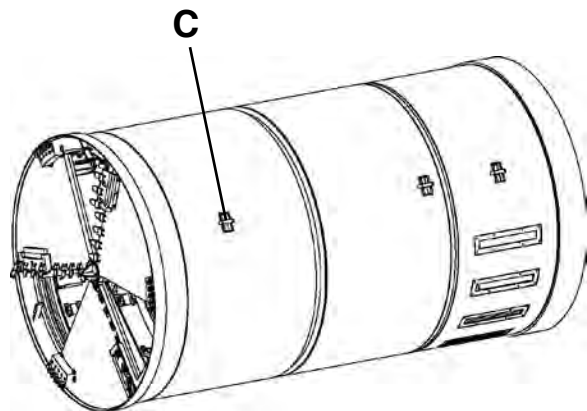

#### 47. INSPECT MOTOR SPROCKETS

Inspect motor sprocket for wear or damage. Remove guard and if sprocket tooth flat is less than 3/8" (9.5 mm), the sprocket must be replaced.

If sprocket is damaged, replace sprocket.

Replace covers before operation.

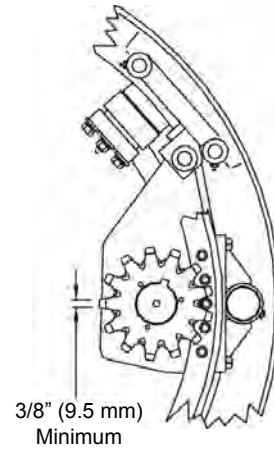

#### 48. INSPECT DRUM ROLLERS

Inspect drum rollers (A) for wear. If roller bearing does NOT spin freely or has play, replace drum roller bearings.

The drum rollers should rotate from the 2 o'clock to 10 o'clock position. If the rollers rotate less than 2 to 10 o'clock, remove shims (B). If rollers rotate more than 2 to 10 o'clock, add shims.

Replace covers before operation.

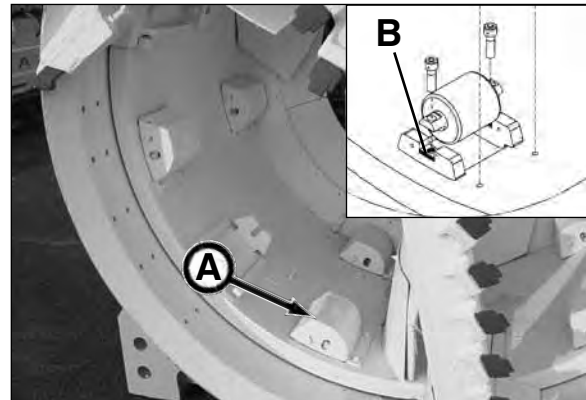

#### 49. INSPECT MOTOR BRACKET

Inspect motor bracket (C) and hardware for wear or damage. Replace as needed.

Replace covers before operation.

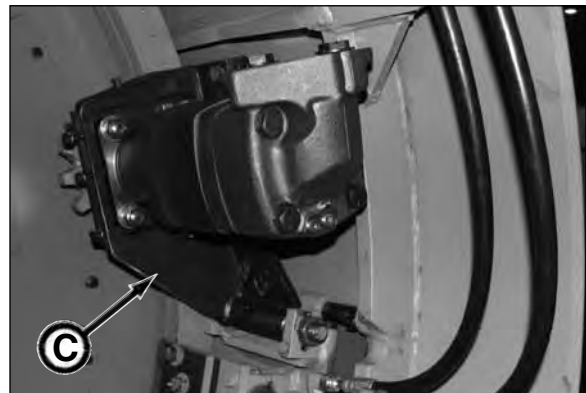

#### 50. DRAIN WATER FROM HYDRAULIC RESERVOIR

Remove water contamination by draining water from the reservoir (D) at the completion of each drive.

1. With the TBM on level ground, allow oil in hydraulic reservoir to settle overnight.
2. Loosen drain plug (E) and drain (into a properly sized catch pan) until there is no water in oil.
3. Once water is removed from tank, tighten drain plug.
4. Add hydraulic oil to reservoir (if necessary).

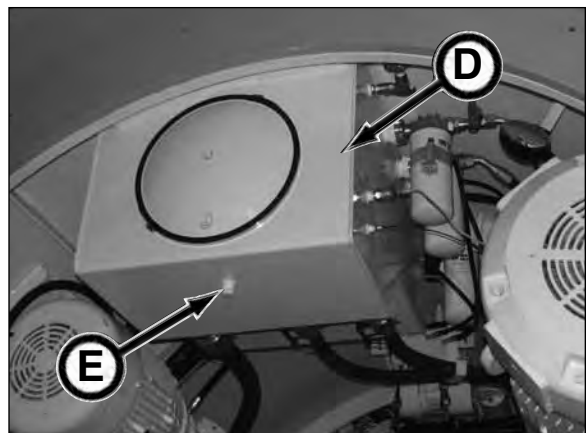

## MAINTENANCE CHARTS - BELT CONVEYOR

Use the item number in the chart to refer to the detailed maintenance procedures later in this section.

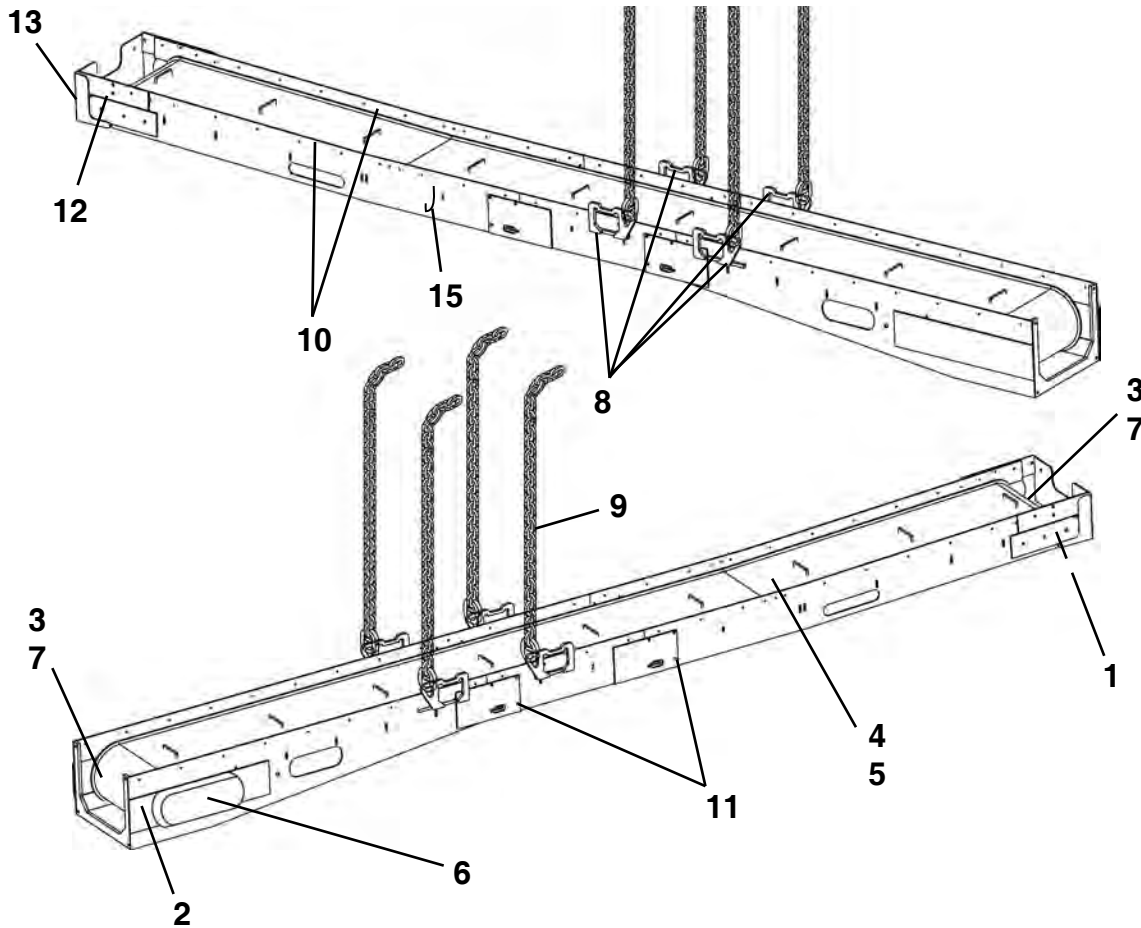

### PRIOR TO EACH JOB LAUNCH

ITEM	COMPONENT	SERVICE	REQUIREMENT	MATERIAL
1.	Front Roller	Inspect & Lubricate	If damaged, replace with new.	Mobil XHP222
2.	Drive Roller & Brg.	Inspect & Lubricate	If damaged, replace with new.	Mobil XHP222
3.	Roller Scrapers	Inspect	If damaged, replace with new.	
4.	Belt	Inspect	Replace if worn, cracked or damaged.	
5.	Belt Tension	Check	At center, max. 6" deflection.	
6.	Drive Chain	Inspect & Lubrication	Check for wear and tightness.	Mobil XHP222
7.	Belt Scrapers	Inspect	If damaged, replace with new.	
8.	Lift Eyes	Inspect	If damaged, replace with new.	
9.	Lifting Chain	Inspect	If damaged, replace with new.	
10.	Spoils Guide	Inspect	If damaged, replace with new.	
11.	Idler Rollers	Inspect & Lubricate	If damaged, replace with new.	Mobil XHP222
12.	Nose Bracket & Brg.	Inspect & Lubricate	If damaged, replace with new.	Mobil XHP222
13.	Dirt Guard	Inspect	If damaged, replace with new.	
*14.	Hydraulic Hoses	Inspect	If worn or damaged, replace with new.	
15.	Safety Hook	Inspect	If damaged, replace with new.	
*16.	Decals	Inspect		

\* Not Shown

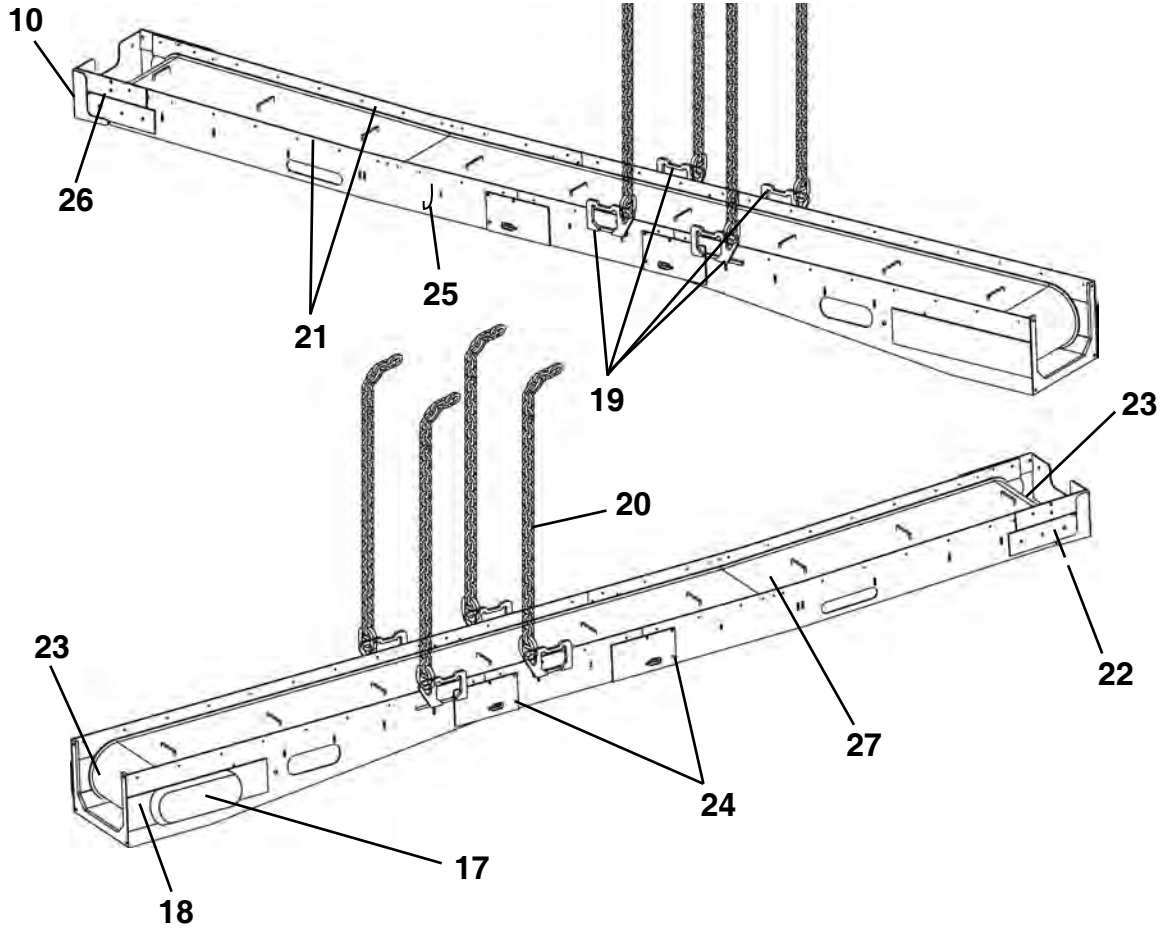

**DAILY OR EVERY 10 HOURS OF OPERATION OR EACH SHIFT CHANGE**

ITEM	COMPONENT	SERVICE	REQUIREMENT	MATERIAL
17.	Drive Cover	Inspect	If damaged, replace with new.	Mobil XHP222
18.	Drive Roller & Brgs.	Inspect & Lubricate	Replace if cracks/wear visible	
19.	Lift Eyes	Inspect	If damaged, replace with new.	
20.	Lifting Chain	Inspect	If damaged, replace with new.	
21.	Spoils Guide	Inspect	If damaged, replace with new.	
22.	Front Roller	Inspect	If damaged, replace with new.	
23.	Belt Scrapers	Inspect	If damaged, replace with new.	
24.	Idler Rollers	Inspect & Lubricate	If damaged, replace with new.	
25.	Safety Hook			
26.	Nose Bracket & Brg	Inspect & Lubricate	If damaged, replace with new.	
27.	Belt	Inspect	Replace if worn, cracked or damaged.	Mobil XHP222
*28.	Decals	Inspect		
*29.	Hydraulic Hoses	Inspect	If worn or damaged, replace with new.	

\* Not Shown

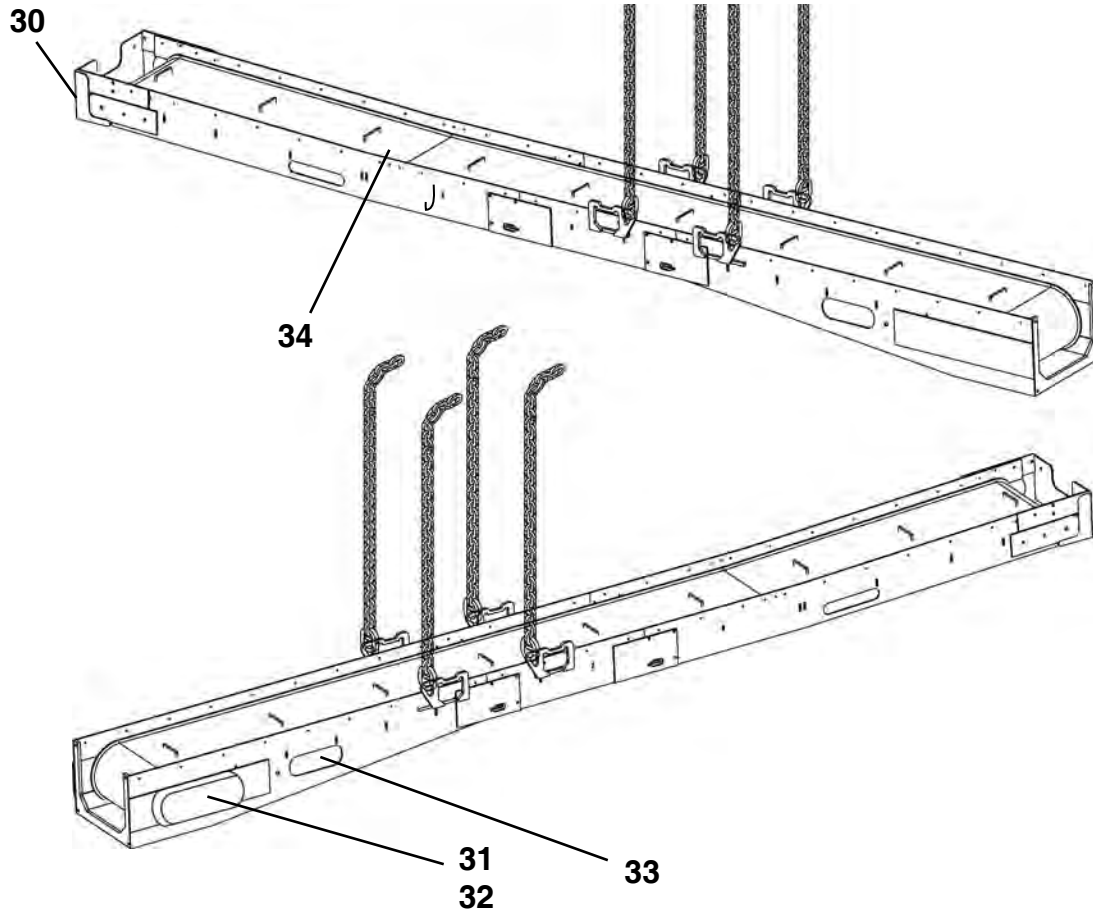

**WEEKLY OR EVERY 50 HOURS OF OPERATION**

ITEM	COMPONENT	SERVICE	REQUIREMENT	MATERIAL
30.	Dirt Guard	Inspect	If damaged, replace with new.	Mobil XHP222
31.	Drive Motor Bolts	Inspect for tightness	If damaged, replace with new.	
32.	Drive Chain	Inspect & Lubrication	Check for wear and tightness.	
33.	Belt Adjust Screw	Inspect & Lubricate		
34.	Belt Tension	Check	At center, max. 6" deflection.	

\* Not Shown

## PRIOR TO EACH JOB LAUNCH

### 1. INSPECT & LUBRICATE FRONT ROLLER

Inspect front roller (A) for wear or damage. If worn or damaged, replace with new.

Lubricate front roller bearings (B) (2 places) with Mobilgrease® XHP222 Premium Lubricating Grease or equivalent until grease is forced out.

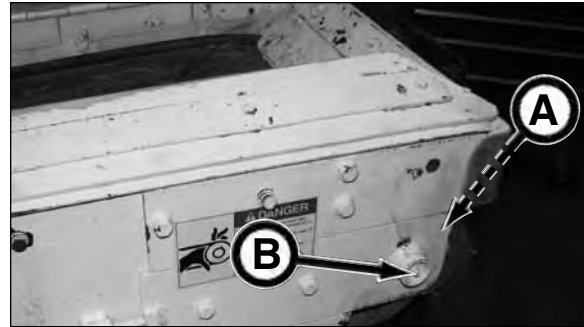

### 2. INSPECT & LUBRICATE DRIVE ROLLER & BEARING

1. Remove guard.
2. Inspect drive roller (C) for wear or damage. If worn or damaged, replace with new.
3. Lubricate drive roller pillow block bearings (D) (2 places) with Mobilgrease® XHP222 Premium Lubricating Grease or equivalent until grease is forced out.
4. Replace guard before operating conveyor.

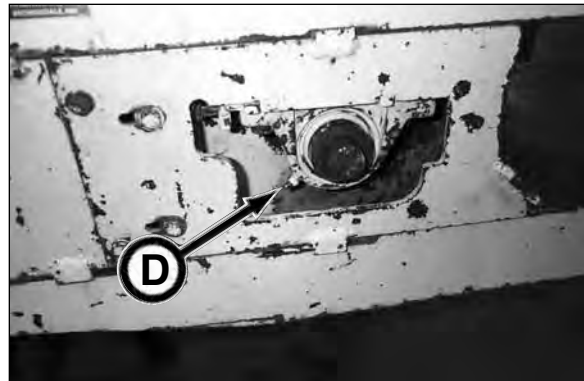
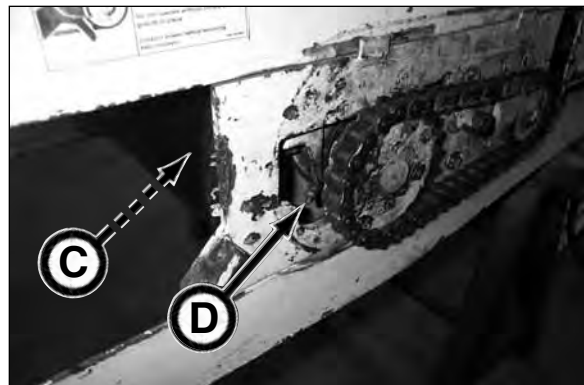

### 3. INSPECT ROLLER SCRAPERS

Inspect front roller (A) and the internal drive roller (B) scrapers for wear or damage. If worn or damaged, replace with new.

Check to be sure scrapers are adjusted so they are approximately 1/16 in. (1.5 mm) from the rollers.

Before operating conveyor, replace any cover/guards that were removed for this inspection.

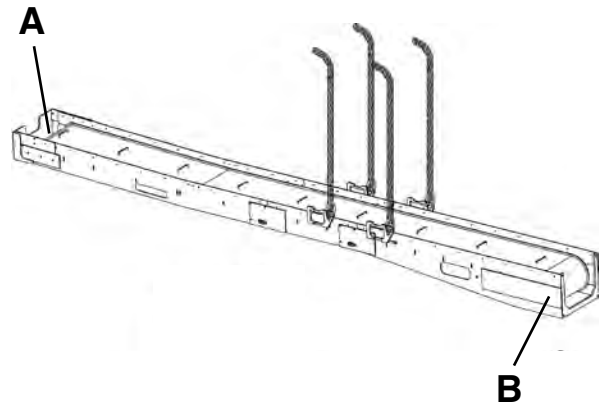

*Internal Drive Roller Scraper Adjustment*

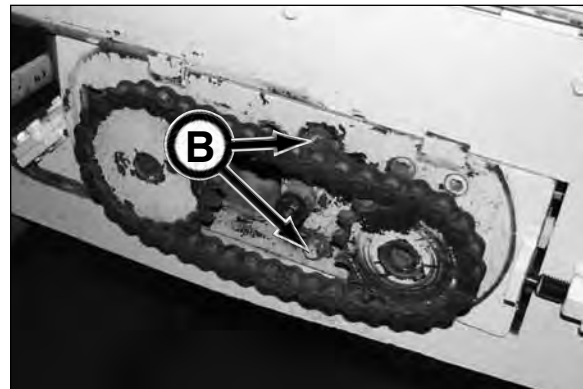

*Internal Drive Roller Scraper Adjustment*

### 4. INSPECT BELT

Inspect belt for cracks, wear, or damage. At the first sign of cracks, wear, or damage, replace conveyor belt.

Conveyor belt should be replaced if:

- The side ribs are worn to the point of no longer able to hold material.
- Cracks in the belt.
- Holes in the belt.
- Multiple belt lugs are missing.
- Belt can no longer be adjusted due to stretch in the belt.



## 5. CHECK BELT TRACKING & TENSION

**Check the belt tracking as follows:**

**⚠ WARNING** Contact with rotating conveyor belt or rollers will cause severe injury or death. Keep hands, body, and objects clear of rotating conveyor.

1. Remove or rotate spoil guides up out of the way of belt.
2. With personnel away from conveyor, start the conveyor belt rotation.
3. Observe the belt tracking the entire length of the conveyor. The gap between the belt and the conveyor must be the same on both sides.

**⚠ WARNING** NEVER adjust tracking while belt is rotating. Doing so can result in serious injury.

4. If the tracking requires adjustment, stop belt rotation and make small adjustments by using BOTH tracking adjustment bolts (A).
5. Start belt rotation and observe belt tracking. If further adjustment is needed, repeat steps 4 and 5 until the belt tracks straight on conveyor.
6. Once belt is tracking properly, stop belt rotation and lock out power to conveyor.

**Check conveyor belt tension by:**

1. Remove or rotate spoil guides up out of the way of belt.
2. In the center of the conveyor, lift the belt (B) and measure the deflection. The deflection should be a maximum of 6 in. (152 mm).

**NOTICE** Be sure the center rib on the under side of the belt stays in the groove of pulley.

**Adjusting conveyor belt tension:**

1. Use BOTH adjustment screws to tighten belt to a 6 in. (152 mm) deflection in the center of the conveyor. Use a tape measure to measure the distance from the conveyor frame (C) to the drive motor frame (D). This distance must be the same on both sides of the conveyor.

**NOTICE** Be sure to tighten BOTH adjustment screws the same rate or distance. Failure to do so will cause premature wear in the belt due to the tension being different on each side of the belt.

2. Once proper belt tension is achieved, the inner belt scrapers need to be readjusted for a 1/16 in. (1.5 mm) clearance.

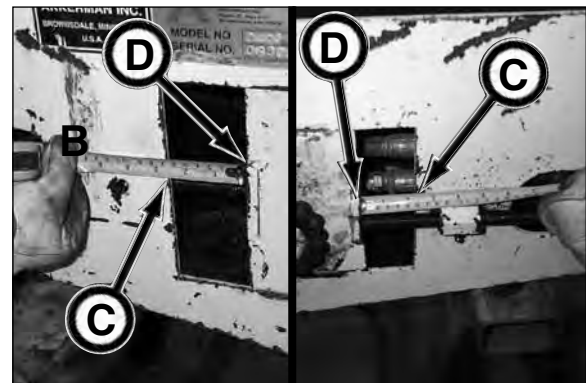

## 6. INSPECT & LUBRICATE DRIVE CHAIN

Inspect drive chain (A). If worn or damaged, replace with new.

Thoroughly lubricate chain with Mobilgrease® XHP222 Premium Lubricating Grease or equivalent.

Replace cover before operating conveyor.

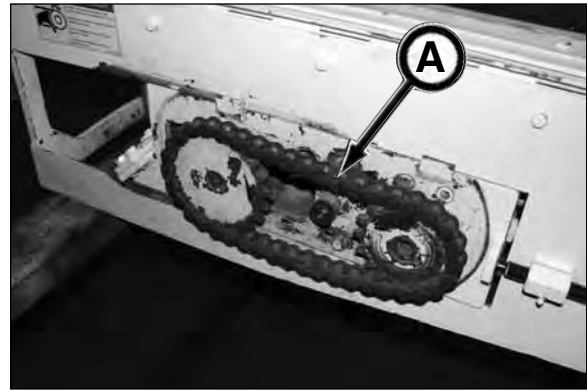

## 7. INSPECT BELT SCRAPERS

Inspect belt scrapers for wear or damage. If worn or damaged, replace with new.

Check to be sure scrapers are adjusted so they are approximately 1/16 in. (1.6 mm) from the belt.

**⚠ WARNING** Contact with rotating conveyor belt or idler rollers will cause severe injury or death. Keep hands, body, and objects clear of rotating conveyor.

Once scrapers are adjusted, run the conveyor belt and make sure the scrapers do not contact the belt. If so, the scrapers **MUST** be readjusted. Once adjusted, stop belt rotation and lock out power to conveyor.

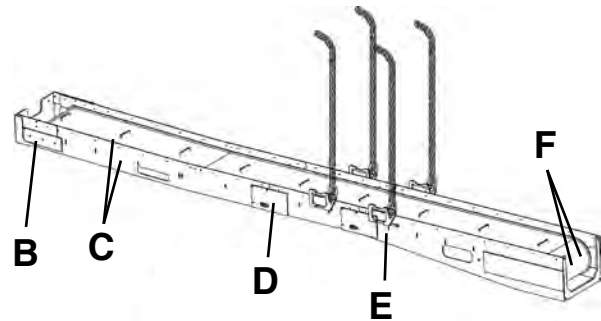

- B - Front End External Belt Scraper
- C - Inner Belt Scraper (2)
- D - Idler Roller Scraper for Extension Frame
- E - Idler Roller Scraper for Drive Frame
- F - External Belt Scraper (2)

## 8. INSPECT LIFTING EYES

Inspect lifting eyes (G) for wear or damage. If worn or damaged, replace with new.



### 9. INSPECT LIFTING CHAINS

Inspect lifting chains (A) for wear or damage. If worn or damaged, replace with new.

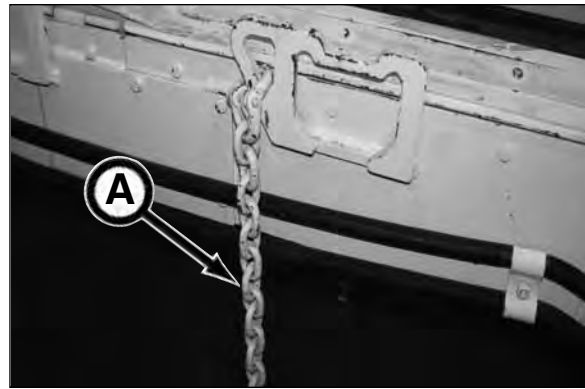

### 10. INSPECT SPOILS GUIDES

Inspect spoils guides (B) for wear or damage. If guide cannot be adjusted to within 1/4 in. (6.4 mm) of the belt, the guide should be replaced. Otherwise if damaged, replace with new.



### 11. INSPECT & LUBRICATE IDLER ROLLERS

Inspect idler rollers (C) for wear or damage. If worn or damaged, replace with new.

Lubricate idler roller bearings (D) (4 places) with Mobilgrease® XHP222 Premium Lubricating Grease or equivalent until grease is forced out.

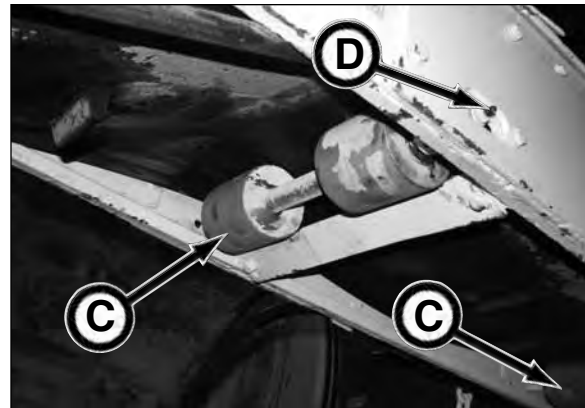

### 12. INSPECT & LUBRICATE NOSE BRACKET & BEARING

Inspect nose bracket (E) for wear or damage. If worn or damaged, replace with new.

Lubricate nose bearing (F) with Mobilgrease® XHP222 Premium Lubricating Grease or equivalent until grease is forced out.

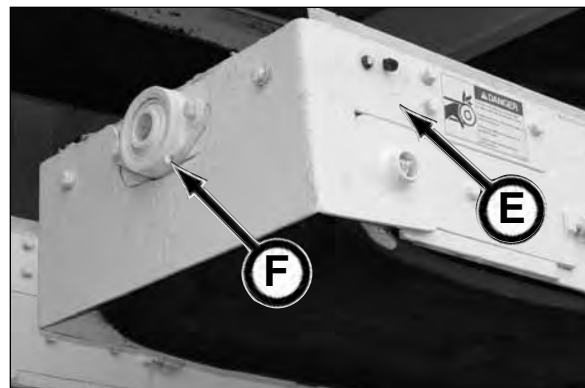

### 13. INSPECT DIRT GUARD

Inspect dirt guard (A) for wear or damage. If worn or damaged, replace with new.

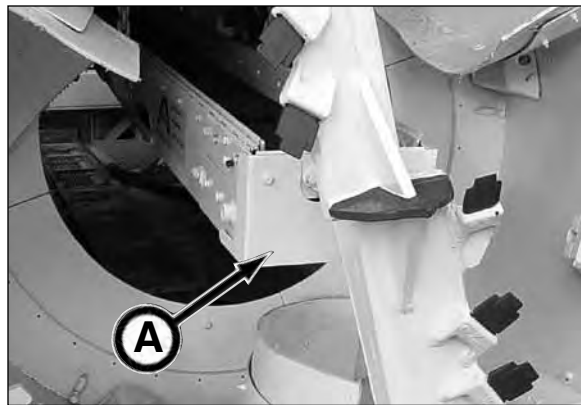

### 14. INSPECT HYDRAULIC HOSES

Inspect hydraulic hoses (B) for wear or damage. Repair or replace BEFORE operation.

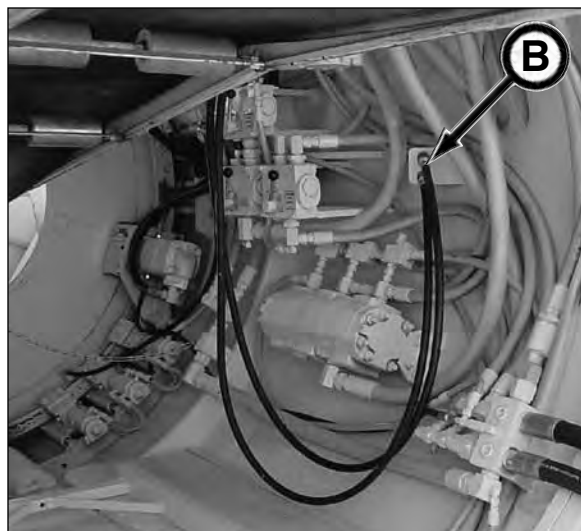

### 15. INSPECT CONVEYOR SAFETY HOOK

Inspect hook (C) for wear or damage. If worn or damaged, replace with new.



### 16. INSPECT DECALS

Inspect ALL decals, operational and safety decals to be sure they are clean and readable.

Use soft cloth, water, and a mild soap to clean the decals if they are too dirty to read. DO NOT clean safety decals with solvent. Solvent will damage decals. Replace decals immediately if they are damaged, missing, or hard to read.

Before applying a new decal, be sure the surface is clean and dry.



## DAILY OR EVERY 10 HOURS OF OPERATION OR EACH SHIFT CHANGE

### 17. INSPECT DRIVE CHAIN COVER

Inspect drive chain (A) for wear or damage. If worn or damaged, replace with new.

NEVER operate conveyor without cover in place.

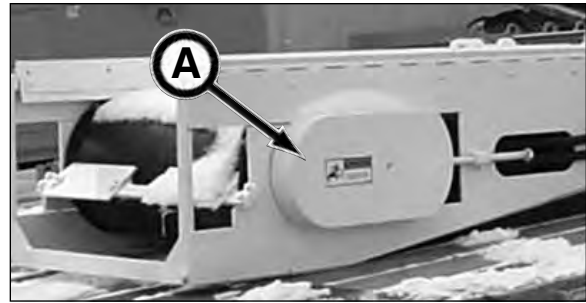

### 18. INSPECT & LUBRICATE DRIVE ROLLER & BEARING

1. Remove guard.
2. Inspect drive roller (C) for wear or damage. If worn or damaged, replace with new.
3. Lubricate drive roller pillow block bearings (D) (2 places) with Mobilgrease® XHP222 Premium Lubricating Grease or equivalent until grease is forced out.
4. Replace guard before operating conveyor.

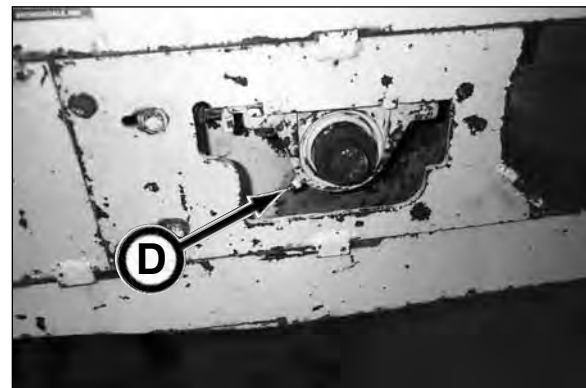
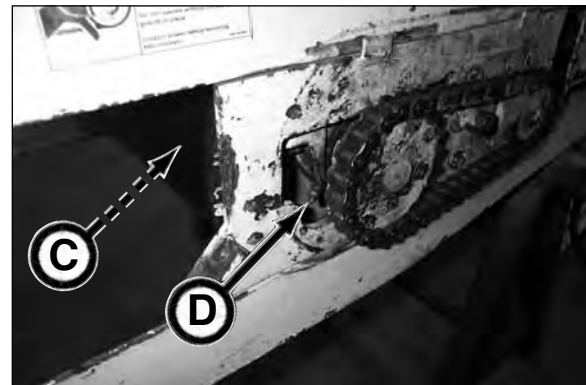

### 19. INSPECT LIFTING EYES

Inspect lifting eyes (E) for wear or damage. If worn or damaged, replace with new.



## 20. INSPECT LIFTING CHAINS

Inspect lifting chains (A) for wear or damage. If worn or damaged, replace with new.

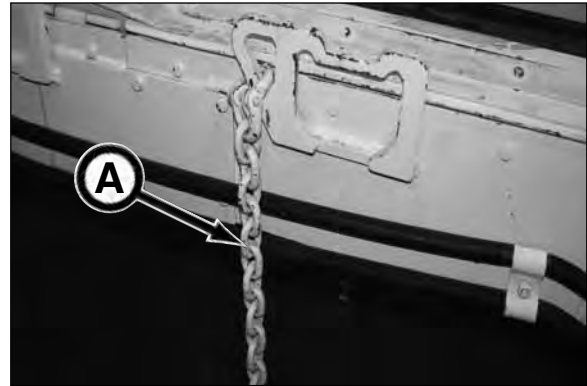

## 21. INSPECT SPOILS GUIDES

Inspect spoils guides (B) for wear or damage. If guide cannot be adjusted to within 1/4 in. (6.4 mm) of the belt, the guide should be replaced. Otherwise if damaged, replace with new.



## 22. INSPECT & LUBRICATE FRONT ROLLER

Inspect front roller (C) for wear or damage. If worn or damaged, replace with new.

Lubricate front roller bearings (D) (2 places) with Mobilgrease® XHP222 Premium Lubricating Grease or equivalent until grease is forced out.

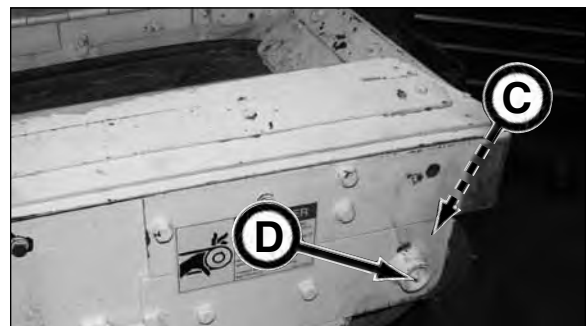

### 23. INSPECT BELT SCRAPERS

Inspect belt scrapers for wear or damage. If worn or damaged, replace with new.

Check to be sure scrapers are adjusted so they are approximately 1/16 in. (1.5 mm) from the belt.

**⚠ WARNING** Contact with rotating conveyor belt or idler rollers will cause severe injury or death. Keep hands, body, and objects clear of rotating conveyor.

Once scrapers are adjusted, run the conveyor belt and make sure the scrapers do not contact the belt. If so, the scrapers **MUST** be readjusted. Once adjusted, stop belt rotation and lock out power to conveyor.

- A - Front End External Belt Scraper
- B - Inner Belt Scraper (2)
- C - Idler Roller Scraper for Extension Frame
- D - Idler Roller Scraper for Drive Frame
- E - External Belt Scraper (2)

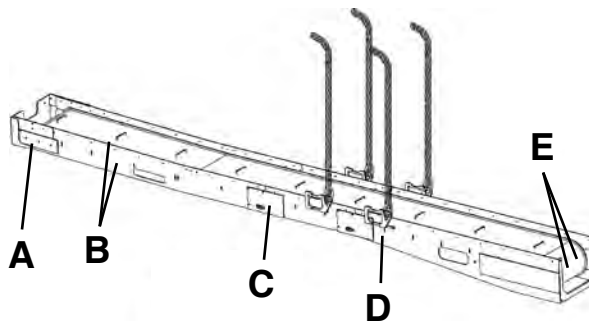

### 24. INSPECT & LUBRICATE IDLER ROLLERS

Inspect idler rollers (F) for wear or damage. If worn or damaged, replace with new.

Lubricate idler roller bearings (G) (4 places) with Mobilgrease® XHP222 Premium Lubricating Grease or equivalent until grease is forced out.

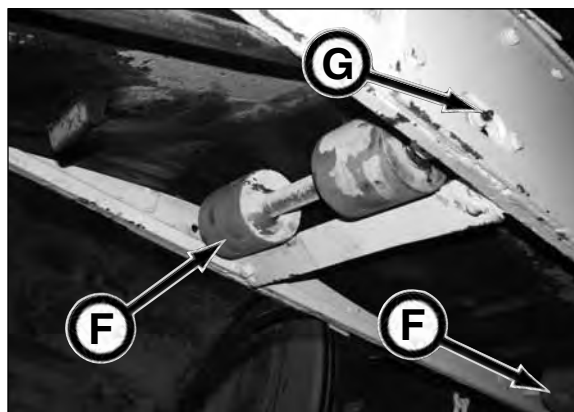

### 25. INSPECT CONVEYOR SAFETY HOOK

Inspect hook (H) for wear or damage. If worn or damaged, replace with new.



## 26. INSPECT & LUBRICATE NOSE BRACKET & BEARING

Inspect nose bracket (A) for wear or damage. If worn or damaged, replace with new.

Lubricate nose bearing (B) with Mobilgrease® XHP222 Premium Lubricating Grease or equivalent until grease is forced out.

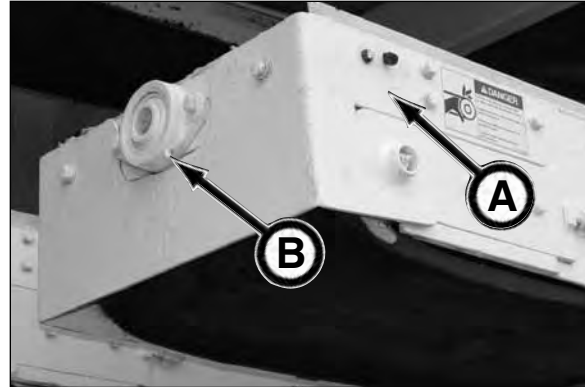

## 27. INSPECT BELT

Inspect belt for cracks, wear, or damage. At the first sign of cracks, wear, or damage, replace conveyor belt.

Conveyor belt should be replaced if:

- The side ribs are worn to the point of no longer able to hold material.
- Cracks in the belt.
- Holes in the belt.
- Multiple belt lugs are missing.
- Belt can no longer be adjusted due to stretch in belt.



## 28. INSPECT DECALS

Inspect ALL decals, operational and safety decals to be sure they are clean and readable.

Use soft cloth, water, and a mild soap to clean the decals if they are too dirty to read. DO NOT clean safety decals with solvent. Solvent will damage decals. Replace decals immediately if they are damaged, missing, or hard to read.

Before applying a new decal, be sure the surface is clean and dry.



## 29. INSPECT HYDRAULIC HOSES

Inspect hydraulic hoses (A) for wear or damage. Repair or replace BEFORE operation.

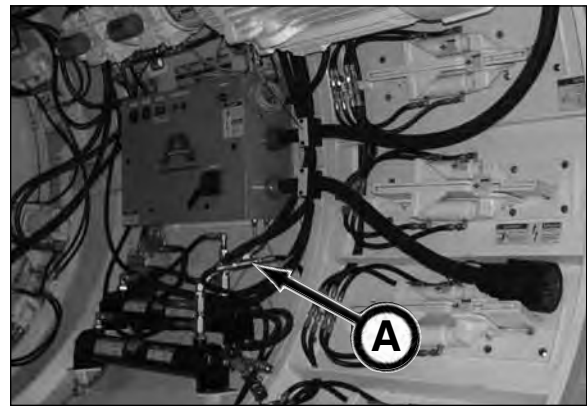
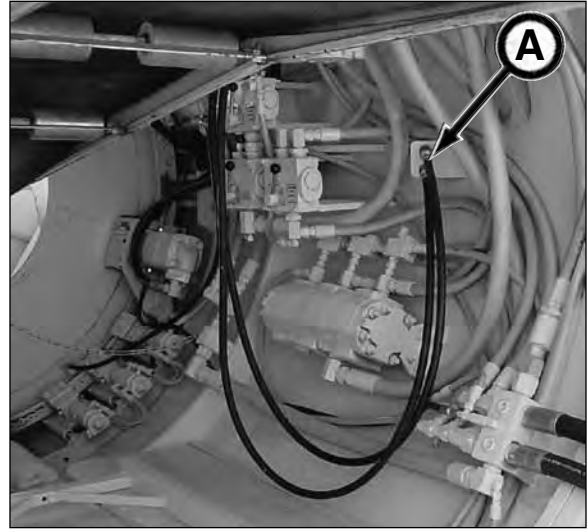

## WEEKLY OR EVERY 50 HOURS OF OPERATION

### 30. INSPECT DIRT GUARD

Inspect dirt guard (A) for wear or damage. If worn or damaged, replace with new.

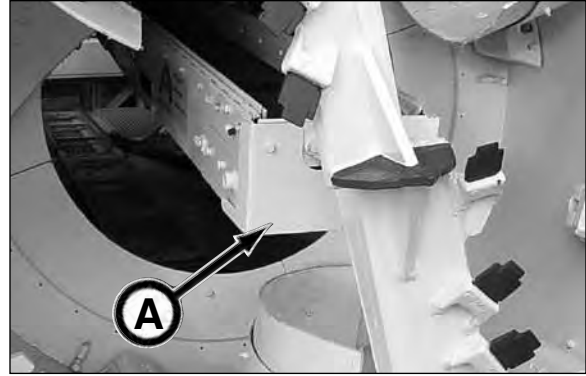

### 31. CHECK DRIVE MOTOR BOLT TIGHTNESS

Check drive motor bolt (B) tightness. Tighten bolts to the following torque:

3/8 in.	40 ft-lb. (54 N·m)
1/2 in.	90 ft-lb. (122 N·m)

If bolt (s) do not hold torque, the bolts must be replaced with new.



### 32. INSPECT & LUBRICATE DRIVE CHAIN

1. Inspect drive chain (C). If worn or damaged, replace with new.
2. Check chain tension. The center of the chain should have a maximum deflection of 3/16 in. (4.8 mm).

To adjust chain tension, loosen bolts (D) on pillow block bearings and tighten chain adjustment bolt (E) until the 3/16 in. (4.8 mm) deflection is achieved. Then retighten pillow block bearing bolts.

3. Thoroughly lubricate chain with Mobilgrease® XHP222 Premium Lubricating Grease or equivalent.

Replace cover before operating conveyor.

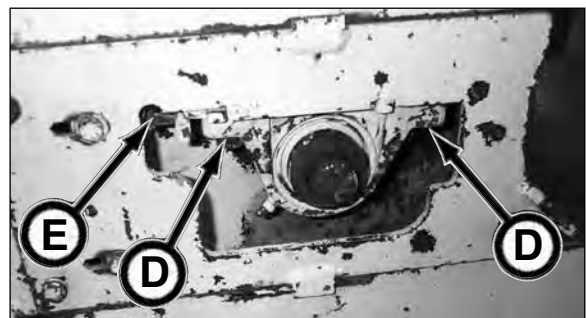
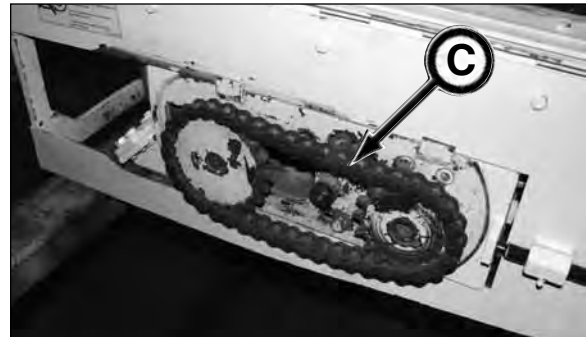

### 33. INSPECT & LUBRICATE BELT ADJUSTMENT SCREW

Inspect belt adjustment screw for wear or damage. If worn or damaged, replace with new.

Lubricate belt adjustment screw (2 places) with one shot of Mobilgrease® XHP222 Premium Lubricating Grease or equivalent.



### 34. CHECK BELT TRACKING & TENSION

**Check the belt tracking as follows:**

**⚠ WARNING** Contact with rotating conveyor belt or rollers will cause severe injury or death. Keep hands, body, and objects clear of rotating conveyor.

1. Remove or rotate spoil guides up out of the way of belt.
2. With personnel away from conveyor, start the conveyor belt rotation.
3. Observe the belt tracking the entire length of the conveyor. The gap between the belt and the conveyor must be the same on both sides.

**⚠ WARNING** NEVER adjust tracking while belt is rotating. Doing so can result in serious injury.

4. If the tracking requires adjustment, stop belt rotation and make small adjustments by using BOTH tracking adjustment bolts (A).
5. Start belt rotation and observe belt tracking. If further adjustment is needed, repeat steps 4 and 5 until the belt tracks straight on conveyor.
6. Once belt is tracking properly, stop belt rotation and lock out power to conveyor.



(continued on next page)

**Check conveyor belt tension by:**

1. Remove or rotate spoil guides up out of the way of belt.
2. In the center of the conveyor, lift the belt (A) and measure the deflection. The deflection should be a maximum of 6 in. (152 mm).

**NOTICE** Be sure the center rib on the under side of the belt stays in the groove of pulley.



**Adjusting conveyor belt tension:**

1. Use adjustment screws (2 places) to tighten belt to a 6 in. (152 mm) deflection in the center of the conveyor. Use a tape measure to measure the distance from the conveyor frame (B) to the drive motor frame (C). This distance must be the same on both sides of the conveyor.

**NOTICE** Be sure to tighten BOTH adjustment screws the same rate or distance. Failure to do so will cause premature wear in the belt due to the tension being different on each side of the belt.

2. Once proper belt tension is achieved, the inner belt scrapers need to be readjusted for a 1/16 in. (1.5 mm) belt clearance.



# Storage

---

## PREPARING FOR STORAGE

### NOTICE

Follow the lubrication and maintenance requirements in the Periodic Maintenance section.

1. Repair worn or damaged parts.
2. Wash all equipment thoroughly.
3. Lubricate all equipment grease points . Grease threads on bolts used for adjustments.
4. Retract all hydraulic cylinders if possible. If not, coat exposed cylinder rods with a corrosion preventive.
5. Repaint equipment where necessary.
6. Drain hydraulic oil, flush oil reservoir, change hydraulic filters, and refill hydraulic reservoir. Check for leaks.
7. Drain oil coolers/heat exchangers.
8. Wipe up lube spills. Dispose of rags and trash properly. Store oily rags and other flammable material in protective containers.
9. If possible, store equipment under cover and out of the weather in a ventilated, clean, dry area.
10. Do not smoke in areas where flammable materials are stored.
11. Remove laser guidance system and place it in storage box.
12. Store fuels and lubricants in properly marked containers.
13. Loosen belt on belt conveyor.

---

## REMOVING FROM STORAGE

### NOTICE

Follow the lubrication and maintenance requirements in the Periodic Maintenance section.

1. Clean equipment thoroughly.
2. Check to make sure all decals including safety decals are clean and readable.
3. Check condition of wires and cables. Repair or replace as necessary.
4. Remove the cylinder corrosion preventive from the cylinder rods if it is not compatible with hydraulic oil or seal materials.
5. Check for leaks. Repair or replace as necessary.
6. Check hydraulic oil level in reservoir. If fluid is low, check for leaks and add oil as required. Refer to Lubricants section.
7. Check condition of all hoses and connections. Tighten, repair or replace with new as needed.
8. Before operating, cycle hydraulic functions several times to purge air from the hydraulic system.
9. Tighten belt tension on belt conveyor.
10. Review this Operator's Manual.

*Storage*

## **NOTES**

# Troubleshooting

---

## TBM 960B

Problem	Cause	Solution
<b><i>No hydraulic power at boring head:</i></b>		
1. Check pressure reading at TBM - Gauge reads 0 psi.	Motors not running.	Turn on Boring Head motor.
	Motors not running due to soft starter fault.	Refer to Soft Starter User Manual.
	Conveyor safety switch is in tripped position.	Reset safety switch.
	Suction valves closed.	Open boring head and auxiliary suction valves.
2. No power to TBM.	Power cable not connected to pit box.	Secure all connections.
	Pit box not powered.	Turn on power.
	Pit box or main breaker is off.	Turn breaker on.
	Power cord not connected to motor control box.	Connect power cord.
	E-Stop pushed in.	Pull E-Stop out.

*(Continued on next page)*

<b>Problem</b>	<b>Cause</b>	<b>Solution</b>
<b>TBM Cutter Bar Stalling:</b>		
Pressure reading at TBM with drum stalled:		
1. Gauge reads 0 psi.	Conveyor safety switch tripped.	Reset switch.
2. Gauge reads more than 500 psi but less than 2000 psi.	Pump compensator set too low.	Reset to 3,000 psi.
	Charge pressure low.	Reset to 250 psi.
	Dirty charge filter(s).	Replace both charge filters.
	Pump weak.	Test/replace pump.
	Check if inner drum advance makes gauge read 2,800 psi when valve is held on and cylinders reach the end of travel.	
	1. If case drain flow is more than 1 GPM per motor: worn or damaged drive motor(s).	Repair or replace drive
	2. If case drain flow is less than 1 GPM per motor. motor ok, see 3 below.	
	3. Pump weak.	Test/replace pump.
3. Check pressure reading at gauge reads 2800 psi.	Worn/missing cutter teeth.	Replace.
	Obstacle in cut path.	Remove obstacle.
	If using CF, doors are closed.	Open doors as needed.
	Drive motor sprocket incorrectly engaged in drive gear.	Check gear wear and drive motor to gear ring clearance (backlash).
	Machine advancement rate too fast.	Slow advancement rate.
	Incorrect cutter teeth for ground condition.	Change to correct teeth.
	Insufficient number of drive motors installed.	Add drive motors.
	Motor(s) hydraulic hoses connected for wrong rotation on one or more motor.	Disengage all motors and test rotation.

(Continued on next page)

<b>Problem</b>	<b>Cause</b>	<b>Solution</b>
<b><i>TBM Dirt Wing will not extend/retract.</i></b>	Control valve pressure set too low.	Increase pressure.
	Bent dirt wing.	Repair or replace.
	Worn or damaged cylinder seal.	Replace seals.
	Material build up or obstruction in ramp travel area.	Remove dirt wing, disassemble and clean.
<b><i>TBM Drum Advance, Conveyor Lift or Steering does not operate.</i></b>	Control valve pressure is low.	Increase to 3,000 psi.
	Obstacle in travel area.	Remove obstacle.
	Worn or damaged cylinder seal.	Replace seal.
	Check valve did not release.	Replace check valve.
	Auxiliary pump malfunction.	Repair or replace pump.
<b><i>TBM Steering cylinder(s) collapse when forward thrust applied.</i></b>	Worn or damaged check valve.	Replace check valve.
	Faulty cylinder seals.	Replace seals.
	Obstruction against cutter ring.	Remove obstruction.
	Insufficient over-cut clearance.	Readjust over-cut (if available).
	Worn or damaged steering link adjustment screw.	Replace adjustment screw.
	Excessive thrust pressure.	Reduce thrust pressure.
	Faulty check valve.	Replace check valve.
<b><i>TBM will not steer up/down.</i></b>	Line/Grade selector valve not in correct position.	Up for grade. Down for line.
	Worn or damaged cylinder seals.	Replace seals.
	Check valve not releasing.	Replace check valve.
	Low operating pressure.	Reset pressure.
<b><i>TBM will not steer left/right.</i></b>	Steering link nut not being rotated to maintain free travel of shield.	Keep nut free while steering left or right.
	Steering links stretched.	Replace steering link.
	Refer to operation section of this manual for proper operation of steering controls.	

*(Continued on next page)*

<b>Problem</b>	<b>Cause</b>	<b>Solution</b>
<b><i>TBM inner drum will not advance/retract.</i></b>	Material build up in travel area.	Remove build up
	Worn or damaged cylinder seal.	Replace seal.
	Cutting face resistance too high.	Rotate inner drum while advancing.
<b><i>TBM inner drum cylinders collapse when forward thrust is applied.</i></b>	Worn or missing cutter teeth.	Replace teeth.
	Check for faulty valve.	Replace valve.
	Worn or damaged cylinder seal.	Replace seal.
	Faulty check valve.	Replace valve.
	Excessive thrust load.	Reduce thrust.
	Damaged thrust roller pins.	Replace pins.
<b><i>TBM inner drum turns too slowly (can build 2,800 psi).</i></b>	Pilot control not in full stroke.	Move control to full stroke.
	Charge filter plugged.	Replace charge filter.
	Loop flushing block stuck open.	Replace blocks.
<b><i>TBM inner drum turns too slowly in soft ground.</i></b>	Too many motors.	* Remove motor and cap lines.
<b><i>* Removing motors will reduce the cutting torque available. DO NOT exceed 5 rpm.</i></b>		
<b><i>TBM cutter head will not make full revolution.</i></b>	Obstruction in cut path.	Remove obstruction.
	Material build up under inner drum.	Remove build up and check for damage.
<b><i>No power in tunnel.</i></b>	Pit box not powered.	Turn on power.
	Power cable not connected to pit box.	Secure all connections.
	Pit box or main breaker is off.	Turn breaker on.
	Power cord not connected to motor control box.	Connect power cord.
	E-Stop pushed in.	Pull E-Stop out.

## CONVEYOR

Problem	Cause	Solution
<b>Conveyor Stalls:</b>		
1. Check conveyor operating pressure gauge - Gauge reads 500 - 1000 psi.		
<i>TEST: Disconnect conveyor hoses, turn valve on and read pressure gauge, turn valve off.</i>		
a. Gauge reads 2800 psi.	Low belt tension.	Tighten belt tension.
	Broken drive chain.	Replace drive chain.
	Worn or damaged conveyor drive motor.	Replace motor.
	Wet conveyor belt.	Tighten under belt scrapers.
b. Gauge reads less than 1500 psi.	Remote or main control valve not in full stroke.	Move control to full stroke.
	Conveyor safety switch tripped.	Reset.
	Motor worn/leaking.	Replace motor.
	Conveyor quick coupler faulty or not properly connected.	Properly connect coupler or replace.
2. Check conveyor operating pressure gauge - Gauge reads 2800 psi.		
	Obstacle lodged in belt or drive chain.	Remove obstacle. Check belt and drive chain for damage.
	Conveyor quick coupler faulty or not properly connected.	Properly connect coupler or replace.
	Damaged bearing on conveyor.	Replace bearing.

# TBM HYDRAULIC SCHEMATIC

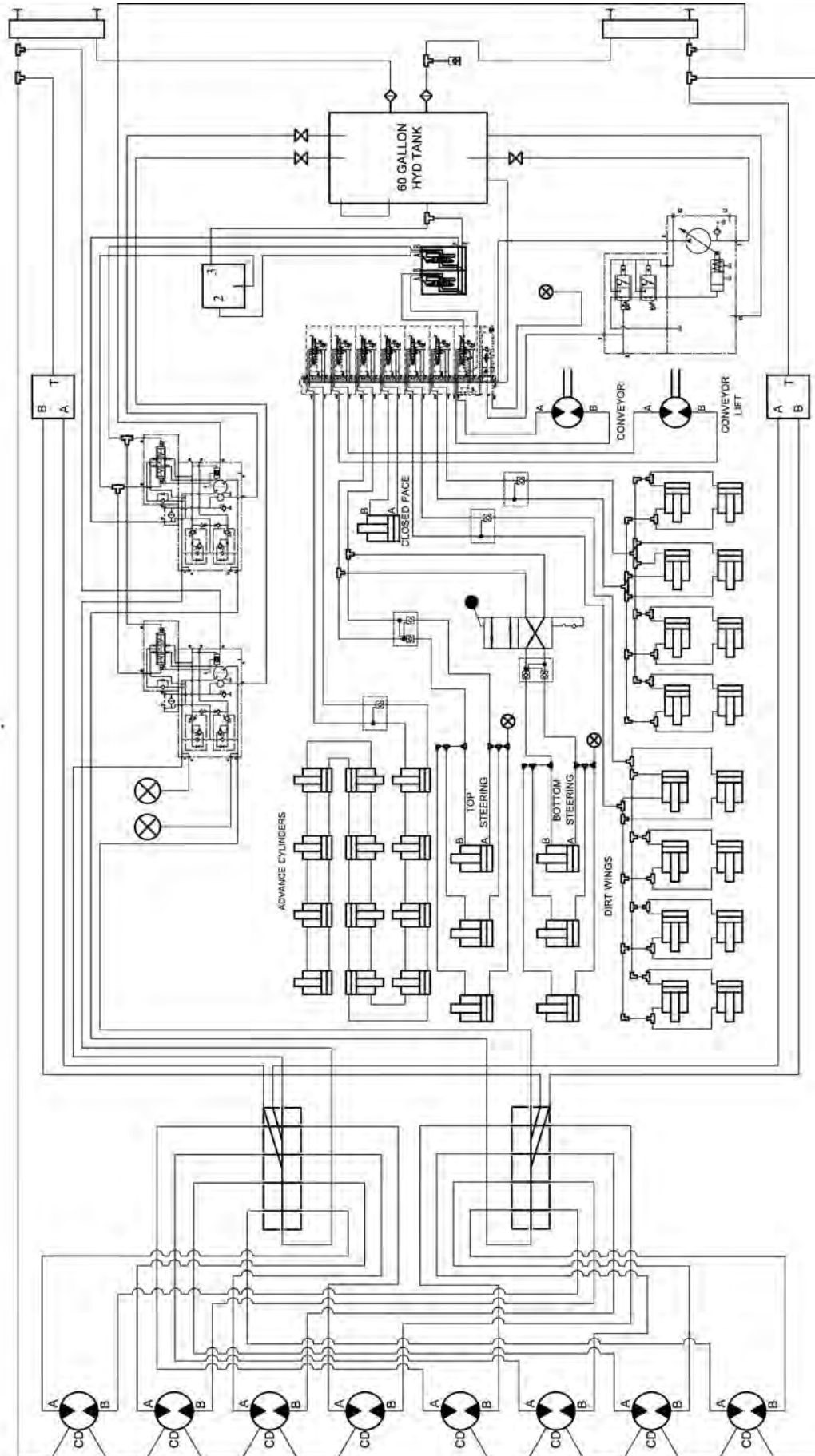

# ELECTRICAL SCHEMATIC - ELECTRICAL CONTROL BOX

REFERENCE TUNNEL CABLE F0054-361

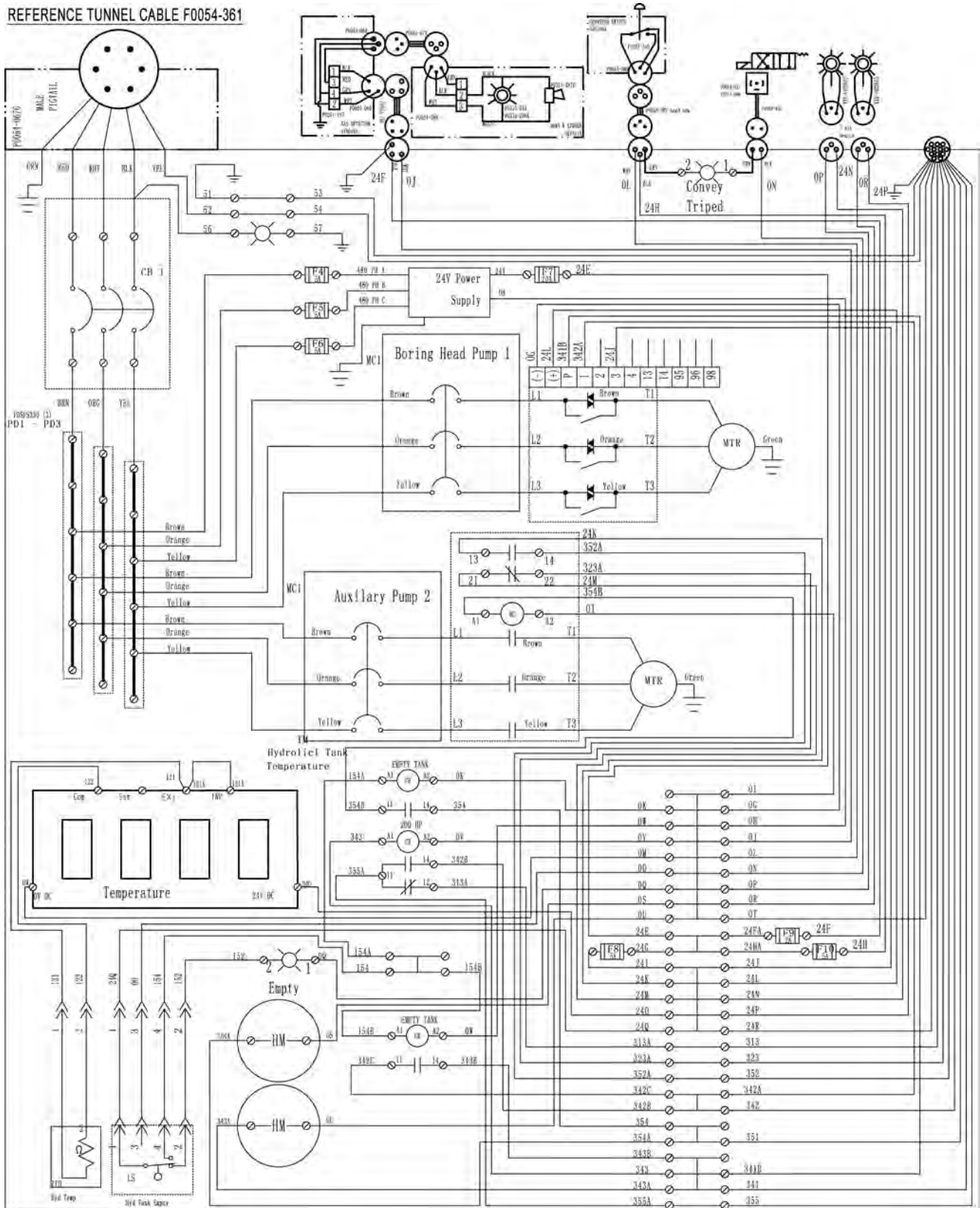

# ELECTRICAL SCHEMATIC - MOTOR CONTROL BOX

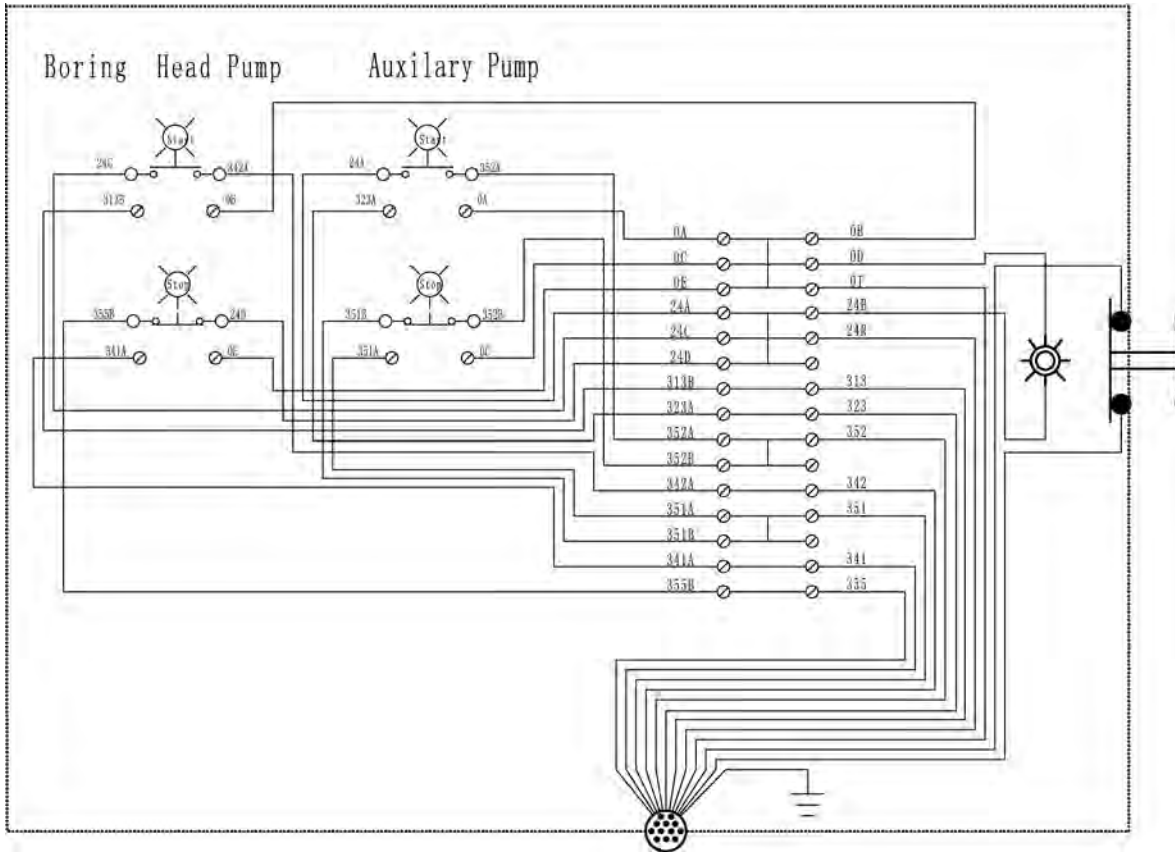

# ELECTRICAL SCHEMATIC - PIT BOX

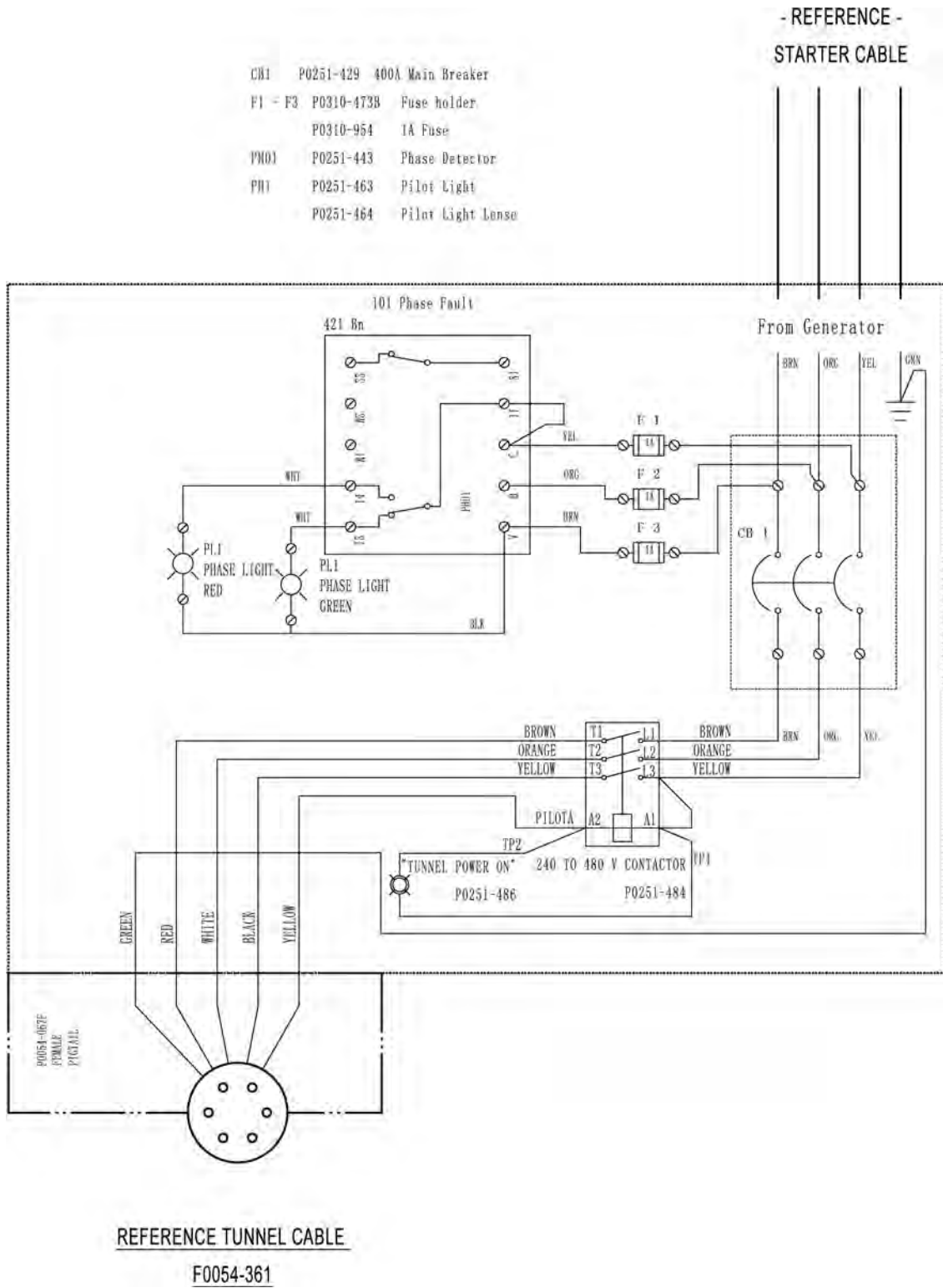

## **NOTES**

# Specifications

## TUNNEL BORING MACHINE

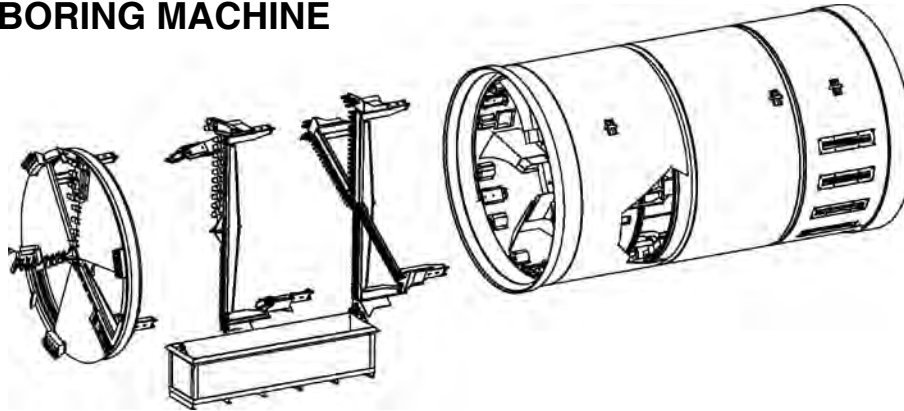

**Weight** (with Closed Face Attachment) ..... 60,000 lbs. (27,216 kg)

### TBM Dimensions

Outside Diameter ..... 114 in. (2,896 mm)  
 Cutting Diameter (overcut)..... 115.5 in. (2,934 mm)  
 Length (with bell ring, no attachment) ..... 205 in. (5,207 mm)

### Hydraulics (Closed Loop System)

Supply ..... 120 Gal @ 3,000 psi  
 Operating Pressure (Maximum) ..... 3,000 psi  
 Filtration ..... Three Return 10 Micron Filters  
 Reservoir ..... 75 gal. (284 L)  
 Cooling ..... Two hydraulic oil coolers (32 gpm @ 5 psi)

### Cutterhead Drive

Rotational Speed ..... Variable in CW  
 Drive Motors  
     Standard ..... (8) 57 CID  
     Maximum ..... 9 (total)  
 Drive Motor Horsepower ..... 30 HP @ 1,800 rpm  
 Cutting Torque ..... 200,000 ft-lbs.  
 Cutting Speed ..... 0 - 4 rpm

### Cutterhead

Standard ..... Dirt/Carbide Cutter Bar  
 Optional ..... Closed Face

### TBM Roll Control

Standard ..... Four Hydraulic CW Dirt Wings, Four Hydraulic CCW Dirt Wings

### Safety Circuit

E-Stop Button Control ..... System Shut Down  
 Conveyor Safety VSwitch ..... CW Rotation Shut Down

### Steering System

Articulation ..... 3 Degrees  
 Number of Cylinders ..... Six  
 Cylinder Stroke ..... 2.25 in. (57 mm)  
 Rated Pressure\* ..... 3,000 psi  
 Operating Pressure ..... 3,000 psi

**\* IMPORTANT: DURING TBM ADVANCEMENT, DO NOT ALLOW STEERING CYLINDER PRESSURES TO EXCEED 3,000 PSI. .**

### Gas Detector

..... Methane Gas

### Electrical

Boring Head Electric Motor (provides 120 gpm @ 3,000 psi)..... 200 HP  
 Auxiliary Electric Motor (provides 14 gpm @ 3,000 psi) ..... 50 HP  
 Operating Voltage ..... 480 VAC 3 Phase  
 Power Supply (to Pit Box) ..... 480VAC, 3 Phase, 60 Hz, 400 Amp  
 Power Supply (from Pit Box to TBM) ..... 480VAC, 3 Phase, 60 Hz, 400 Amp  
 Transformer (for control wiring)..... 480VAC to 24 VDC

*Akkerman Inc. reserves the right to improve its product without notice or obligation.*

---

## CONVEYOR

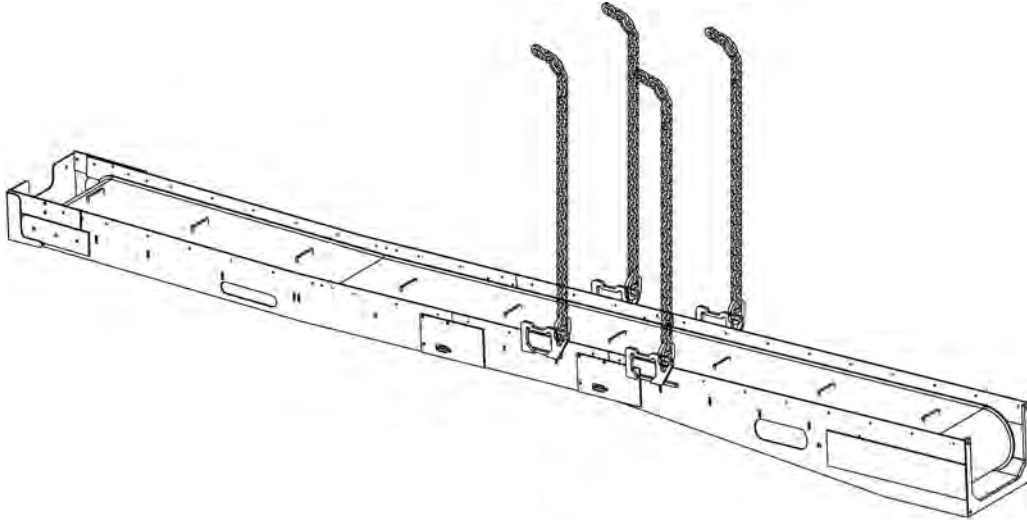

### Belt Conveyor

Model ..... 2415  
Belt Size ..... 24 in. (610 mm)  
Length ..... 15 ft (4,572 mm)

---

## YOKE

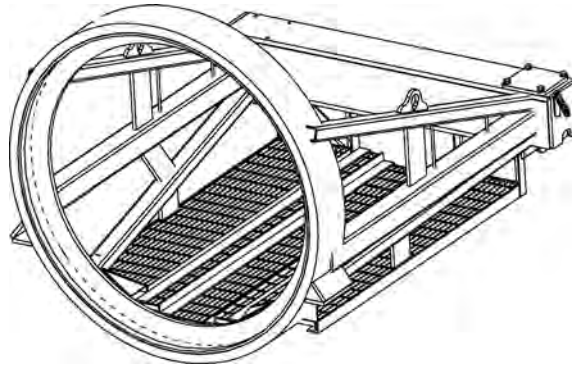

### Yoke

Model ..... 960  
Outside Diameter ..... 114 in. (2,896 mm)  
Inside Diameter ..... 96 in. (2,438 mm)  
Length ..... 123.41 in. (3,135 mm)  
Height ..... 114 in. (2,362 mm)

## SKIDS

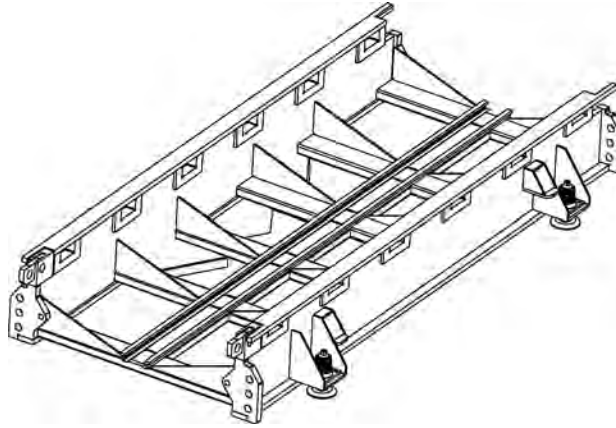

<b>Model</b>	<b>Width</b>	<b>Length</b>	<b>Height</b>	<b>Weight</b>
2.5 ft	80" (2,032 mm)	30" (762 mm)	25.5" (648 mm)	1,500 lbs. (680 kg)
7.5 ft	91" (2,311 mm)	90" (2,286 mm)	25.5" (648 mm)	4,200 lbs. (1,905 kg)
15 ft	91" (2,311 mm)	180" (4,572 mm)	25.5" (648 mm)	8,400 lbs. (3,810 kg)
22.5 ft	91" (2,311 mm)	270" (6,858 mm)	25.5" (648 mm)	12,600 lbs. (5,715 kg)

## **NOTES**

# Identification Numbers

Model and serial numbers are required when ordering parts or requesting service information. Record your model and serial numbers below.

## TUNNEL BORING MACHINE (A)

Model Number \_\_\_\_\_

Serial Number \_\_\_\_\_

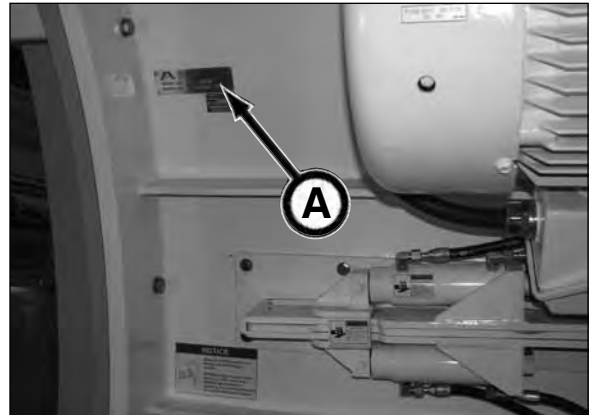

## BELT CONVEYOR (B)

Model Number \_\_\_\_\_

Serial Number \_\_\_\_\_

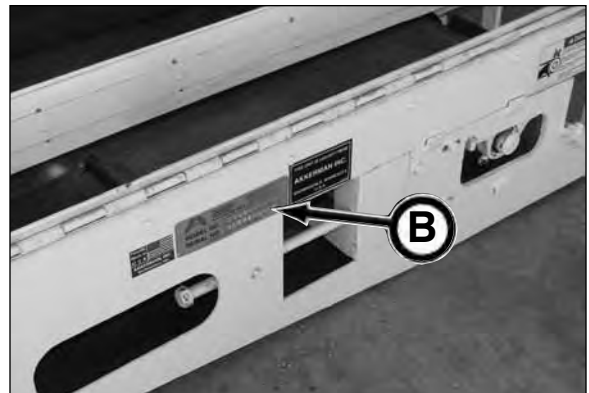

## SKID (C)

Model Number \_\_\_\_\_

Serial Number \_\_\_\_\_

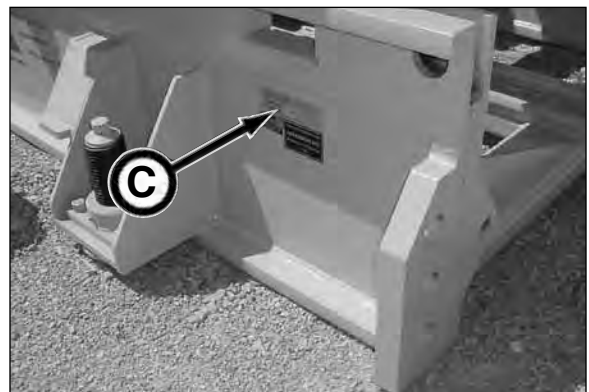

## YOKE (D)

Model Number \_\_\_\_\_

Serial Number \_\_\_\_\_

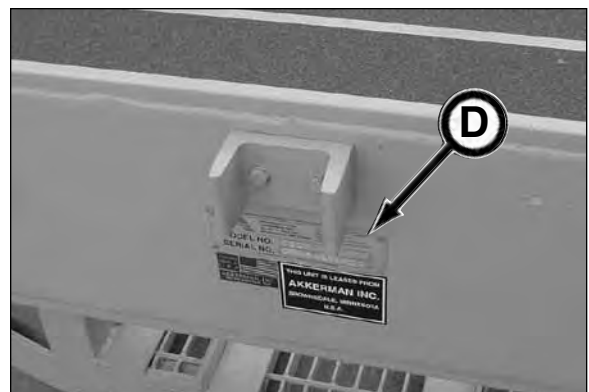

## **NOTES**

# Material Safety Data Sheets

The Federal Occupational, Safety, and Health Administration (OSHA) Standard 29 CFR 1910.1200, require that specific material safety data sheets (MSDS) be available to employees before operating this equipment. This may include information on substances contained in this equipment such as hydraulic fluid and gear lubricant.

Akkerman Inc. will provide, at no cost, MSDS which apply to its product line. Simply contact your Akkerman Aftermarket Support representative for a copy.

To ensure a prompt response to your MSDS request, include your return address (including zip or postal code) and the equipment's model numbers and serial numbers with your request.

## **NOTES**

# Warranty

Akkerman Inc. warrants that all equipment manufactured by it be free from defects due to workmanship or material under normal use and service for a period of 90 days. This warranty does not apply to normal wear items such as cutter teeth, filters, etc. Akkerman Inc. does not warrant the fitness of its equipment for a particular purpose or application.

*Warranty*

## **NOTES**