



# **OPERATOR'S MANUAL**

## **Sliplining System**

**SLS 50/100 SN: F40700F**  
**SLS Power Pack SN: F40862F**

**Publication No. 050163A**

Rev. No. 210525

© Akkerman Inc. 2021  
All Rights Reserved

Akkerman Inc. 58256 266th Street Brownsdale, MN 55918  
Phone: 507-567-2261 Fax: 507-567-2605 email: [akk@akkerman.com](mailto:akk@akkerman.com)

**SERVICE • RELIABILITY • INNOVATION**



# Introduction

This operator's manual contains important safety, operation, and maintenance information for your Akkerman Sliplining System. You must read and understand this manual before you operate and maintain this equipment. Directions in this manual are referenced from the launch shaft going forward to the reception shaft, unless otherwise noted. Keep this manual with your Sliplining equipment at all times. Additional copies of this manual may be purchased from the Akkerman Aftermarket Support Department, or downloaded from the Akkerman web site at [www.akkerman.com](http://www.akkerman.com).

**The contractor is responsible for the overall safety program on the job site. Use this manual as a part of the safety program.**

The use of parts other than genuine Akkerman parts could affect the efficient performance of the Sliplining System. ALWAYS use genuine Akkerman parts.

Understand safety signal words, DANGER, WARNING, CAUTION, SAFETY INSTRUCTIONS, and NOTICE. When you see these words in this manual or on safety decals mounted on your equipment, follow the safety message to avoid personal injury and/or property damage.

**▲ DANGER** Indicates an extremely hazardous situation which, if not avoided, WILL result in death or serious injury.

**▲ WARNING** Indicates a potentially hazardous situation which, if not avoided, COULD result in death or serious injury.

**▲ CAUTION** Indicates a potentially hazardous situation, which, if not avoided, MAY result in minor or moderate injury. It may also be used to alert against unsafe practices.

**SAFETY INSTRUCTIONS** Usually consists of individual messages stating procedures or actions that must be followed for the safe operation of a product.

**NOTICE** Identifies potential property damage and important installation, operator, or maintenance information.



## Akkerman Sliplining System

The Akkerman SLS 50/100 Ton Sliplining System is utilized for rehabilitation of deteriorating pipe lines/ sewer lines. The system is used for insertion of a pipe string into an existing live pipe/sewer line. Once the shaft is constructed, the top half of the existing pipe is removed at the spring line. The sliplining system is then anchored into the starting shaft. The new pipe is positioned on the elevator system, then is lowered into position. The thrust system is actuated to push the pipe axially into position. A retention winch is provided to retain the pipe string from flowing away from the jacking frame due to flow forces of the fluid. A gripping system is also provided and can be positioned at each end of the sliplining system to prevent the pipe string line from flowing back into the frame. The thrust system consists of planetary gearboxes with an interconnected roller chain mechanism. A draw bar is connected to the bottom of the chain on each side of the pipe. A pipe adapter ring is mounted on the draw bar to engage the pipe section. As the gearboxes are simultaneously rotated, the pipe section can be thrust in either direction. The power to the sliplining system is provided by an electric power pack which is located adjacent to the sliplining frame.

If you find any errors with this manual or have suggestions for improvement, please let us know. Email your comments via the Akkerman web site (Contact Us web page), or mail your suggestions to: Akkerman Inc, ATTN: Technical Publications, 58256 266th Street, Brownsdale, MN 55918.

Akkerman Inc. reserves the right to improve its product without notice or obligation.

## **NOTES**

# Contents

<b>Safety</b> .....	<b>1</b>	<b>Operation (continued)</b>	
Be Alert For Safety Information .....	1-1	Connecting Power Pack Hyd. Hoses To Sliplining Frame .....	6-8
Read Operator's Manual .....	1-1	Checkout Equipment Prior To Start-Up .....	6-10
Wear Protective Clothing .....	1-1	Wireless Remote Pendant Start Up .....	6-10
Keep First-Aid Accessible .....	1-1	Power Pack Start Up Procedure .....	6-12
Lockout Tagout Power Before Servicing .....	1-2	Setting Drive Pressure Limit Control .....	6-14
Hydraulic Oil/Fluids Under Pressure .....	1-2	Adjusting Drive Motor Speed Matching .....	6-16
Beware of Suspended Loads .....	1-2	Adjusting PVG Function Speed Control .....	6-18
Keep Away From Rotating & Moving Parts .....	1-2	Setting Display Time, Date & Brightness .....	6-20
Keep Personnel Away From Moving Parts .....	1-3	Viewing Input/Output Data .....	6-20
Inspect Electrical Connections .....	1-3	Viewing Faults .....	6-21
Unauthorized Welding .....	1-3	System Start-Up .....	6-22
Regularly Clean/Inspect Equipment .....	1-3	Check Hydraulics After System Start Up .....	6-23
Avoid Pinch Points .....	1-4	Launch Sequence & Adding New Pipe .....	6-24
Contact With Power Cable .....	1-4	Stopping The Power Pack 166 HP Motor .....	6-30
Practice Safe Maintenance .....	1-4	Filling Hydraulic Reservoir .....	6-31
Test Shaft/Tunnel Ventilation .....	1-5	Daily Shutdown .....	6-34
High Pressure Hydraulics .....	1-5	Remote Access Data .....	6-35
Slippery When Wet .....	1-5	Cold Weather Operation .....	6-39
Wear Safety Harness .....	1-6	Reconfiguring The Sliplining Frame .....	6-40
Fire Prevention .....	1-6	I. Changing Frame Width .....	6-40
No Smoking In Shaft Or Tunnel .....	1-6	II. Changing Frame Length .....	6-42
Keep Job Site Clean & Organized .....	1-6	III. Changing The Thrust Ring .....	6-42
Pathogen Exposure .....	1-7	IV. Changing/Removing Drawbar .....	6-43
Use Handholds, Steps & Platforms .....	1-7	V. Changing The Pipe Clamp Assembly .....	6-43
Using A Pressure Washer Wand .....	1-7	Removing Sliplining System .....	6-44
Recycle Waste .....	1-7		
<b>Safety Decals</b> .....	<b>2</b>	<b>Transporting</b> .....	<b>7</b>
Sliplining Frame .....	2-1	Transporting Guidelines .....	7-1
Sliplining Power Pack .....	2-2	Lifting Instructions .....	7-2
<b>Terminology</b> .....	<b>3</b>	<b>Lubricants</b> .....	<b>8</b>
Sliplining Components .....	3-1	Power Pack Hydraulic Oil Lubricant .....	8-1
Wireless Remote Pendant .....	3-2	Electric Motor Grease .....	8-1
Sliplining Power Pack .....	3-3	Main Drive Planetary Gear Box Lube .....	8-2
Power Pack Control Panel .....	3-4	Elevator Planetary Gear Box Lube .....	8-2
Power Pack Pressure Gauge Panel .....	3-5	Grease .....	8-2
<b>Controls &amp; Instruments</b> .....	<b>4</b>	Drive Chain & Elevator Chain Lube .....	8-3
Emergency Stop .....	4-1	Winch Gear Case Lubricant .....	8-3
Power Phase Indicators .....	4-1	Storing Lubricants .....	8-4
Power Pack Controls .....	4-2		
Wireless Remote Pendant .....	4-4	<b>Periodic Maintenance</b> .....	<b>9</b>
<b>Pre-Start Inspection</b> .....	<b>5</b>	Lubrication and Maintenance Intervals .....	9-1
<b>Operation</b> .....	<b>6</b>	Lockout Tagout Power Before Servicing .....	9-1
Operating Guidelines .....	6-1	Before Performing Maintenance .....	9-1
System Overview .....	6-2	Hydraulic Oil/Fluids Under Pressure .....	9-2
Recommended Tools & Equipment .....	6-3	Avoid Pinch Points .....	9-2
Site Planning .....	6-3	Unauthorized Welding .....	9-2
Site Preparation .....	6-4		
Connecting Power Pack Elect. Connections .....	6-7		

(continued on next page)

<b>Periodic Maintenance (continued).....</b>	<b>9</b>	<b>Troubleshooting .....</b>	<b>11</b>
Maintenance Charts .....	9-3	Sliplining System .....	11-1
Prior To Each Drive Launch .....	9-3	Hydraulic Schematic .....	11-3
Maintenance Detail .....	9-8	Sliplining Frame .....	11-3
Daily Or Every 10 Hours .....	9-4	Sliplining Power Pack .....	11-4
Maintenance Detail .....	9-20	Electrical Schematic .....	11-6
Weekly Or Every 50 Hours .....	9-5	Sliplining Frame .....	11-6
Maintenance Detail .....	9-30	Sliplining Power Pack .....	11-8
Every 100 Hours.....	9-5		
Maintenance Detail .....	9-32	<b>Specifications .....</b>	<b>12</b>
First 150 Hours, Then Every 1000 Hours ..	9-5	Sliplining Frame .....	12-1
Maintenance Detail .....	9-33	Sliplining Power Pack .....	12-2
Monthly Or Every 250 Hours .....	9-5	Torque Chart .....	12-3
Maintenance Detail .....	9-34		
Completion Of Each Drive .....	9-6	<b>Identification Numbers .....</b>	<b>13</b>
Maintenance Detail .....	9-35		
Every 500 Hours .....	9-7	<b>Safety Data Sheets .....</b>	<b>14</b>
Maintenance Detail .....	9-40		
Every 1000 Hours .....	9-7	<b>Warranty .....</b>	<b>15</b>
Maintenance Detail .....	9-41		
Annually .....	9-7	<b>Index .....</b>	<b>16</b>
Maintenance Detail .....	9-47		
<b>Storage .....</b>	<b>10</b>		
Preparing For Storage .....	10-1		
Removing From Storage .....	10-1		

# Safety

---

## BE ALERT FOR SAFETY INFORMATION

When you see this safety alert symbol on your equipment or in this manual, be alert to the possibility of personal injury or property damage.

Read all safety information.

Keep safety decals clean and in good condition. Replace missing or damaged safety decals.



**ATTENTION!  
BECOME ALERT!  
YOUR SAFETY IS INVOLVED!**

---

## READ OPERATOR'S MANUAL

**⚠ WARNING** Unsafe operation or maintenance can cause severe injury or death.

Read and understand the Operator's Manual before operating or servicing this equipment.

Any unauthorized modifications will void the warranty.

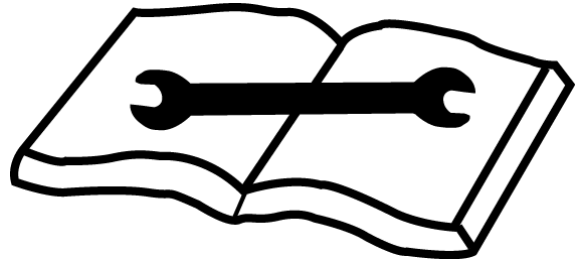

---

## WEAR PROTECTIVE CLOTHING

Wear OSHA approved protective clothing, such as hard hat, gloves, safety goggles, earmuffs or ear plugs, face shield, and steel-toed boots, when operating and servicing this equipment.

Wear reasonably close fitting clothing and remove jewelry before working on or near this equipment. This will help prevent the danger of catching them in moving parts or controls.



---

## KEEP FIRST-AID KIT ACCESSIBLE

Keep a first-aid kit handy and properly maintained. Call 9-1-1 for emergencies.

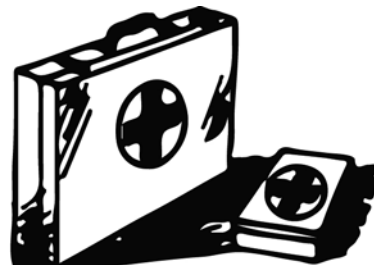

---

## LOCKOUT TAGOUT POWER BEFORE SERVICING

**⚠ DANGER** Failure to lockout tagout power before servicing will cause severe personal injury or death.

LOCKOUT TAGOUT main power supply before servicing. Electrical repairs must be performed only by a certified electrician.



---

## HYDRAULIC OIL/FLUIDS UNDER PRESSURE

**⚠ WARNING** Escaping oil or other fluids under pressure can penetrate your skin causing serious injury or death.

Release all pressure before performing maintenance or repairs. Never weld near pressurized fluid lines.

DO NOT use your hands to check for leaks. When searching for leaks, use a piece of wood or cardboard.

Contact medical help immediately if any oil or fluid is injected into your skin. A serious infection or reaction can emerge without proper medical treatment.



---

## BEWARE OF SUSPENDED LOADS

**⚠ WARNING** Suspended loads may fall and cause severe personal injury or death.

If a hydraulic hose from the boom of a crane or excavator breaks, the boom can fall instantly.

Do not enter area under or around a load.



---

## KEEP AWAY FROM ROTATING & MOVING PARTS

**⚠ DANGER** Contact with rotating or moving parts will cause severe injury or death.

Keep hands, body, and objects clear of operating drive/elevator chains and winch cable.

Do not operate without covers and guards in place.

Lockout/tagout power before servicing.

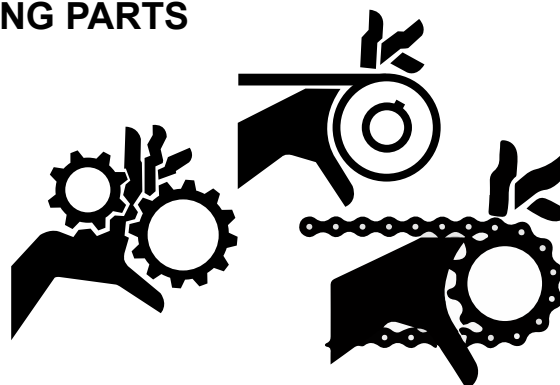

---

## KEEP PERSONNEL AWAY FROM MOVING PARTS

### **⚠ WARNING**

Crushing hazard.  
Keep personnel away from inside of sliplining frame. Failure to do so could result in serious personal injury or death.

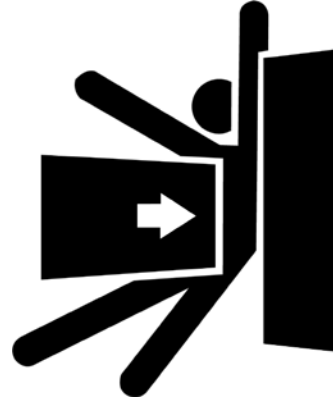

---

## INSPECT ELECTRICAL CONNECTIONS

### **⚠ WARNING**

Regularly inspect electrical connections to be sure they are secure. Failure to do so could cause an explosion if moisture enters an unsecured electrical connection.



---

## UNAUTHORIZED WELDING

### **⚠ WARNING**

Unauthorized welding can cause structural failure resulting in possible injury or death.

Do not weld on any structural member.  
Unauthorized welding or repair will void the warranty.

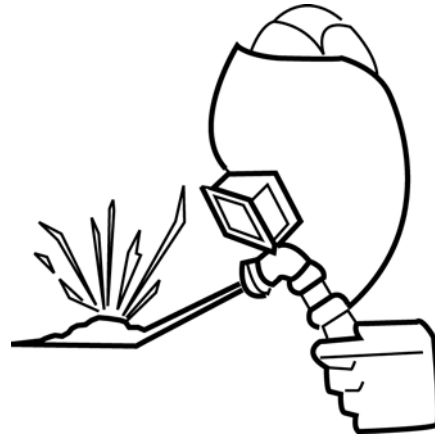

---

## REGULARLY CLEAN AND INSPECT EQUIPMENT

Remove any grease, oil, or debris buildup to avoid potential injury or equipment damage.

Inspect equipment for damage. If damaged, repair or replace immediately.



---

## AVOID PINCH POINTS

**⚠ WARNING** Moving parts or the mishandling of parts can cause severe personal injury.

Keep hands away from moving parts.

Watch your fingers, hands, and legs while equipment is in operation.

Handle parts carefully to avoid crushing and pinch point hazards.

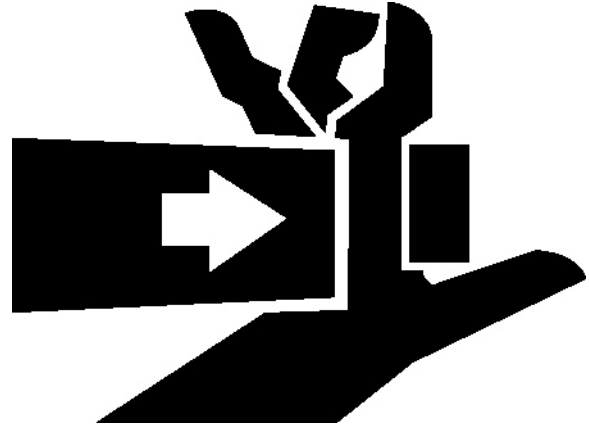

---

## CONTACT WITH POWER CABLE

**⚠ DANGER** Contact with a severed electrical cable WILL cause serious injury or death.

CONSTANTLY monitor electrical cables during drive to prevent cutting or stretching of any electrical cables.



---

## PRACTICE SAFE MAINTENANCE

**⚠ WARNING** Unexpected equipment movement may cause serious personal injury.

LOCKOUT TAGOUT power before performing any maintenance.

Shut down equipment before making repairs, adjustments, or removing obstructions.

Only trained and qualified personnel should perform any maintenance or repairs.

Keep the area around the equipment clean and dry when performing maintenance.

Do not service the machine while it is in motion.

Replace worn or damaged parts. Remove grease, oil, or debris buildup.

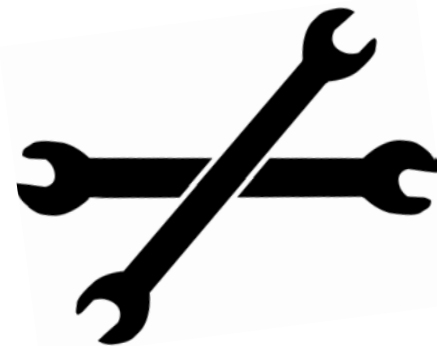

## TEST SHAFT/TUNNEL VENTILATION

**⚠ WARNING** Keep shafts and tunnel well ventilated at all times.

Use an approved air analyzer to detect hazardous gases and oxygen content.

Before and during the shaft operation, test for combustible and toxic gases and oxygen deficiency.

If the levels exceed OSHA prescribed levels, leave shaft and tunnel immediately! Do not activate or deactivate any electrical or hydraulic devices, since any spark could cause an explosion.

Once ALL personnel are out of tunnel/shaft, cut power from power source.

Gases must be removed before reentering tunnel/shaft.

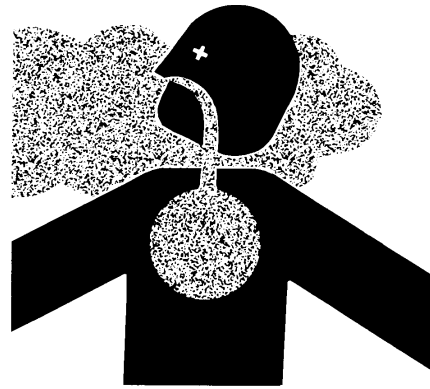

## HIGH PRESSURE HYDRAULICS

**⚠ WARNING** The Sliplining System contains high pressure hydraulics.

Keep all guards in place.



## SLIPPERY WHEN WET

**⚠ WARNING** Slips and falls can cause serious personal injury.

Ensure firm footing in wet or slippery conditions.

Replace skid-resistant material if it is damaged or missing to prevent slips and falls.

Remove any buildup of grease, oil, or debris.



---

## WEAR SAFETY HARNESS

**⚠ WARNING** Falling can cause serious injury or death.

Wear an OSHA approved safety harness while working on the sliplining system.

Proper training is necessary for harness selection, inspection and usage.

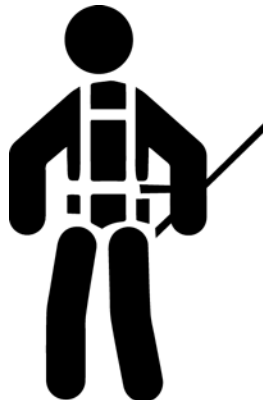

---

## FIRE PREVENTION

**⚠ CAUTION** Fires can cause injury or property damage.

Keep equipment clean. Remove all debris from equipment.

Have fully charged fire extinguishers on the job site at all times.



---

## NO SMOKING IN SHAFT OR TUNNEL

**⚠ WARNING** Smoking in shaft or tunnel could cause an explosion if combustible gases are present.

Do not smoke in shaft or tunnel.



---

## KEEP JOB SITE CLEAN AND ORGANIZED

**⚠ WARNING** Tripping can cause serious personal injury.

Be sure to keep job site clean and organized.



---

## PATHOGEN EXPOSURE

**⚠ WARNING** Exposure to pathogens can cause severe injury or death.

Wear appropriate personal protective equipment (PPE) before any contact with possible pathogens.

Know procedures, practices and vaccination requirements for exposure to pathogens.



---

## USE HANDHOLDS, STEPS & PLATFORMS

**⚠ WARNING** Slips and falls can cause serious personal injury.

When getting on and off sliplining frame, always maintain a three point contact with the handholds, steps and platforms while facing the frame.

NEVER jump on or off the machine.

Be careful of slippery conditions on platforms, steps and handrails



---

## USING A PRESSURE WASHER WAND

**⚠ WARNING** Using a pressure washer wand can generate enough fluid pressure and velocity to penetrate skin resulting in serious personal injury.

Contact medical help immediately if fluid is injected into your skin. A serious infection or reaction can emerge without proper medical treatment.

NEVER point the wand towards a person or animal.

Be sure to release pressure after use and before performing maintenance to prevent accidental fluid injection.

Wear safety glasses and gloves, and depending on the wand use, a particle mask may be necessary.



---

## RECYCLE WASTE

Follow local, state, federal, and international regulations when recycling or disposing of waste. Waste includes fluids/oil, fuel, filters, coolant, and batteries.

Use leakproof containers when draining fluids/oil. Do not pour waste on the ground, down a drain, or into any water source.

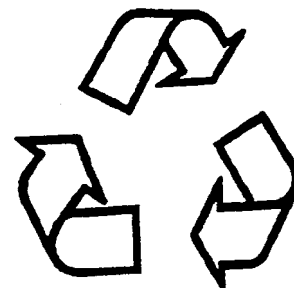

*Safety*

## **NOTES**



# SLIPLINING POWER PACK

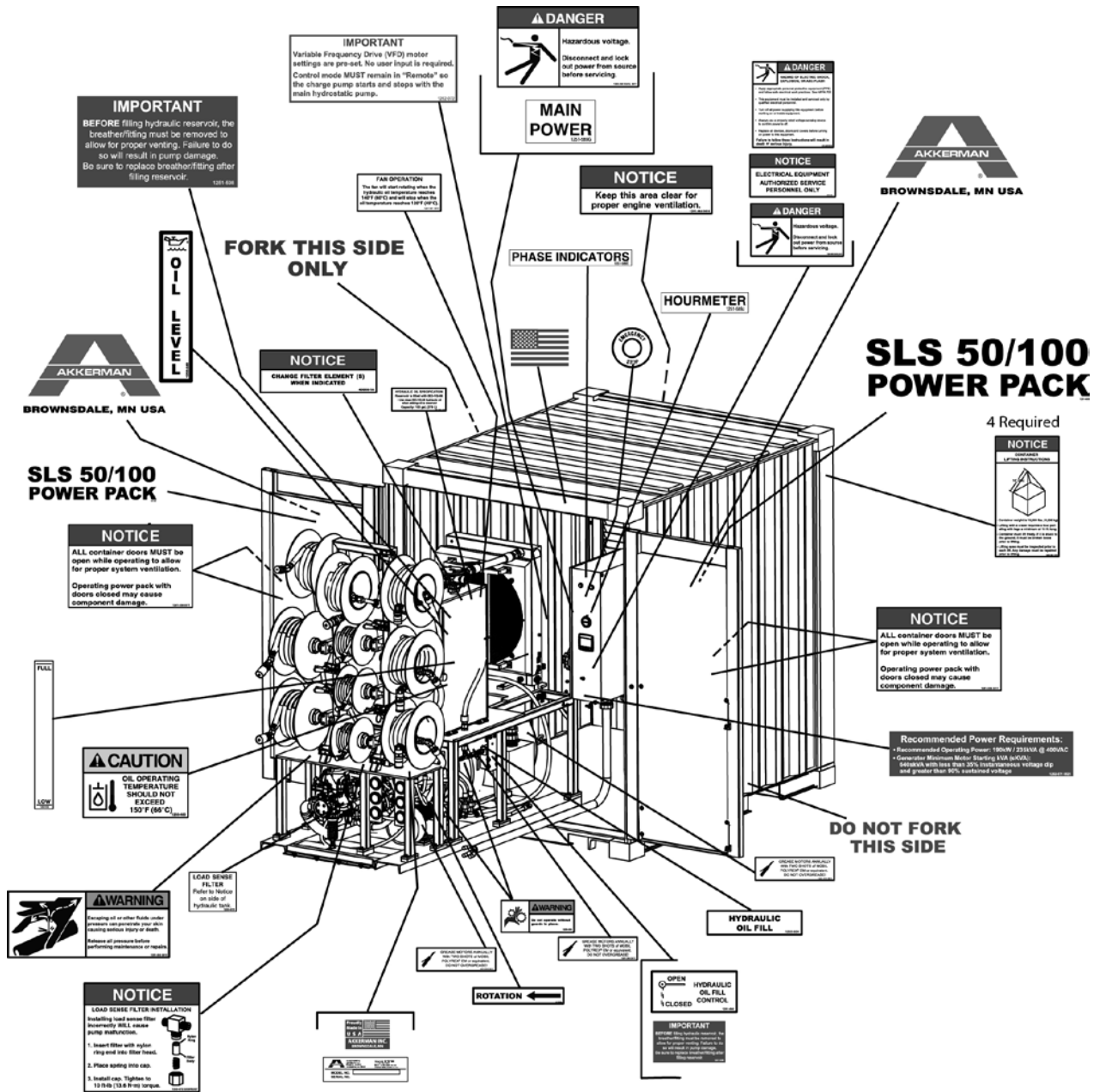

# Terminology

## SLIPLINING SYSTEM COMPONENTS

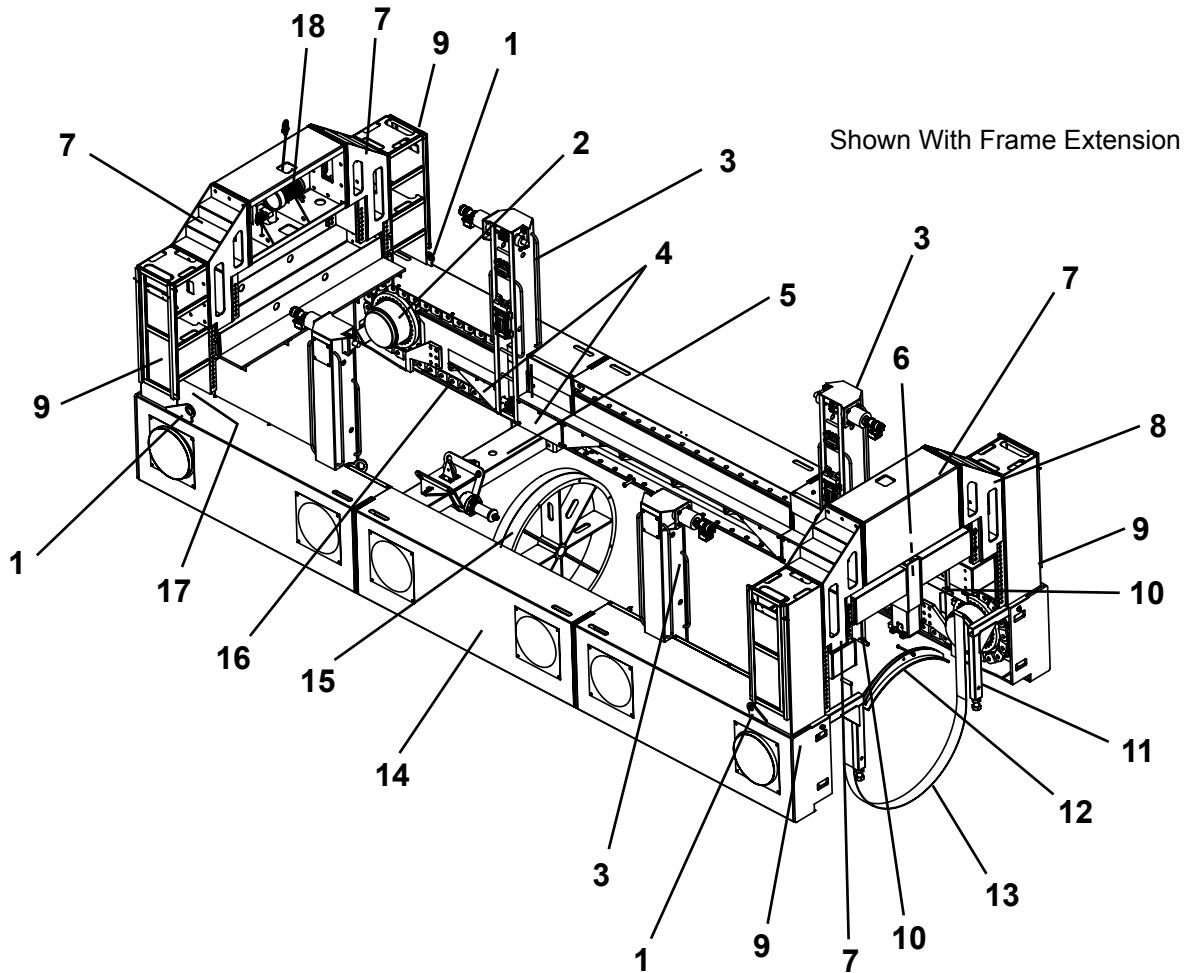

- |                            |                                    |
|----------------------------|------------------------------------|
| 1. Lift Eye                | 10. Connecting Link                |
| 2. Final Drive Motor       | 11. Angle Support                  |
| 3. Elevator                | 12. Pipe Shoe (Gripper)            |
| 4. Main Chain Drive Guards | 13. Pipe Clamp Band                |
| 5. Drawbar                 | 14. Frame Extension (Option)       |
| 6. Pipe Clamp Cylinder     | 15. Thrust Ring                    |
| 7. Center Section          | 16. Main Chain                     |
| 8. Spacer Sections         | 17. Case Drain Thermal Relief Tank |
| 9. Frame Ends              | 18. Winch                          |

## WIRELESS REMOTE PENDANT

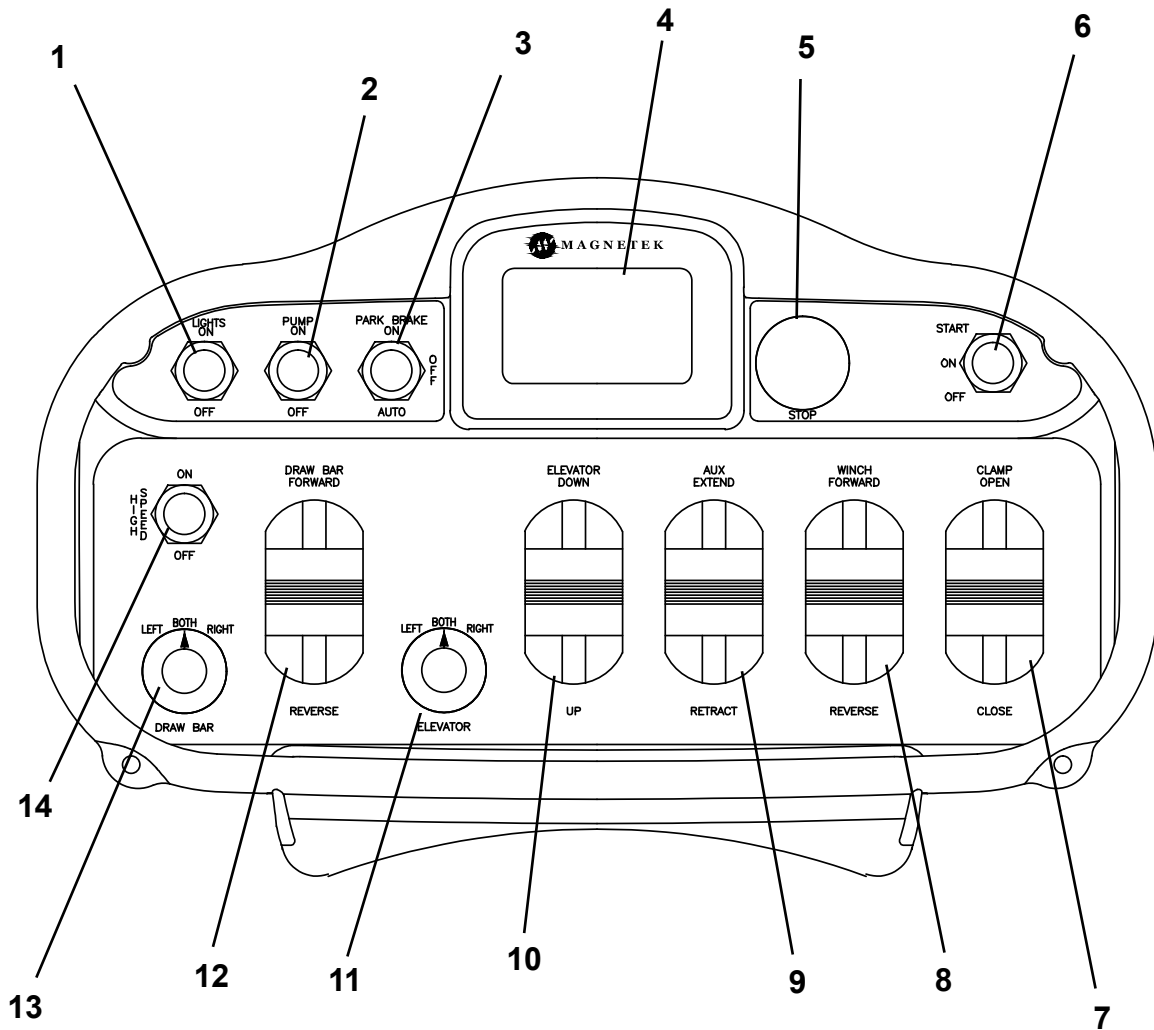

- |  |                                     |
|--|-------------------------------------|
| 1. Light Switch                                  | 8. Winch Control                    |
| 2. Power Pack Main Hyd. Pump Switch              | 9. Auxiliary Cylinder Control       |
| 3. Brake Control Switch                          | 10. Elevator Control                |
| 4. Machine Information LCD Display               | 11. Elevator Three Position Control |
| 5. Emergency Stop (E-Stop) Button                | 12. Drawbar Control                 |
| 6. Controller Start / Control Orientation Switch | 13. Drawbar Three Position Control  |
| 7. Pipe Clamp Control                            | 14. Speed Control Switch            |

## SLIPLINING POWER PACK

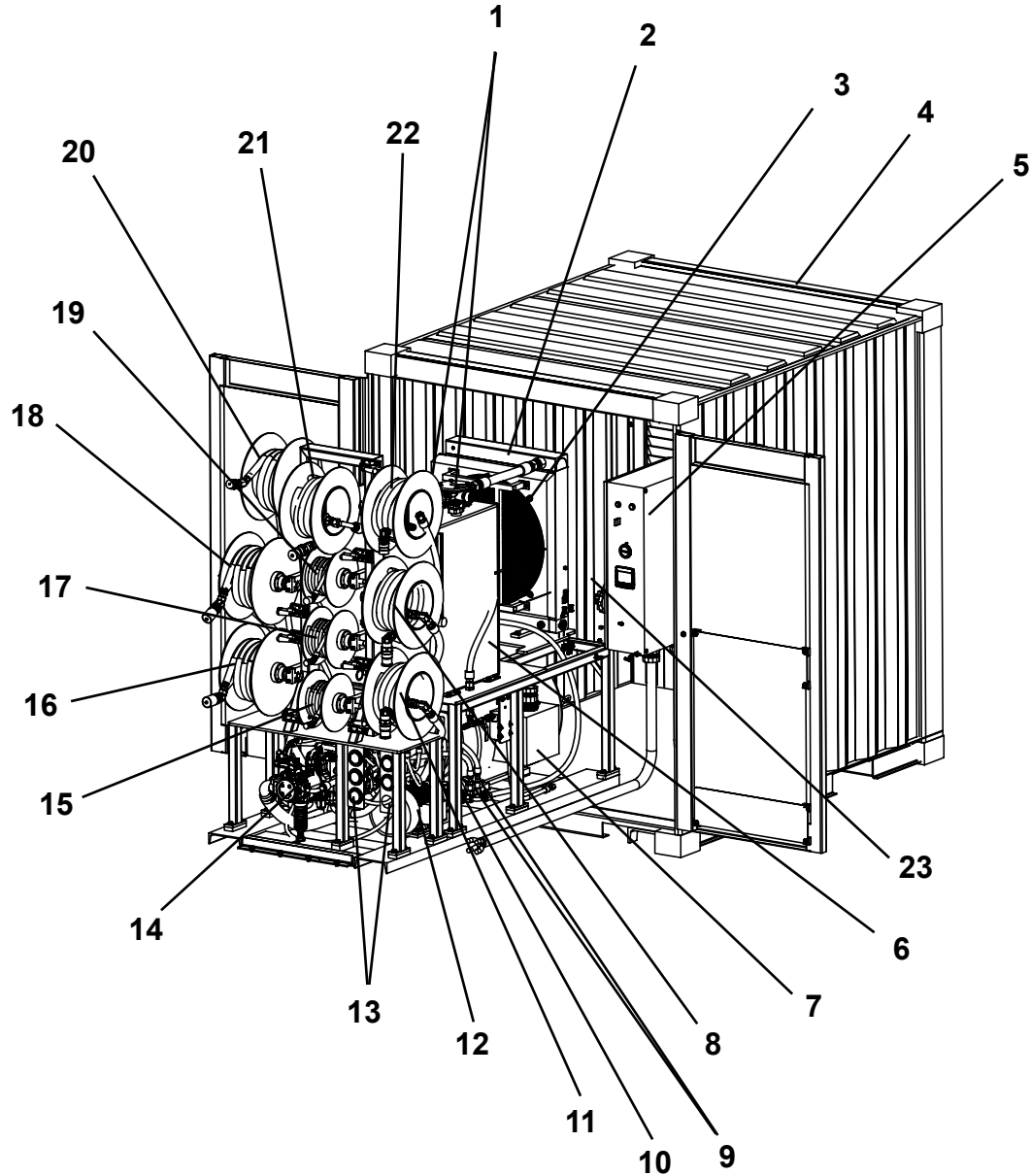

- |  |   |
|--|---|
| 1. Cooling Circuit Return Filter                         | 12. Cooling Motor 5 HP                      |
| 2. Oil Cooler  | 13. Hydraulic Pressure Gauge Panel          |
| 3. Cooling Fan   | 14. Load Sense/5 Section Pump               |
| 4. Container   | 15. Load Sense Hyd. Hose Reel               |
| 5. Power Pack Control Panel                              | 16. Drive Pump 2 Hyd. Hose Reel (B Port)    |
| 6. Hydraulic Reservoir 100 Gal.<br>Oil Temperature Gauge | 17. High Speed Shift/Brake Supply Hose Reel |
| 7. Electric Motor 166 HP                                 | 18. Drive Pump 2 Hyd. Hose Reel (A Port)    |
| 8. Drive Pump 1 Hyd. Hose Reel (B Port)                  | 19. High Speed Shift Brake Return Hose Reel |
| 9. Drive Charge Pumps                                    | 20. Motor Case Drain Hyd. Hose Reel         |
| 10. Cooling Pump   | 21. 5 Section Valve* Return Hyd. Hose Reel  |
| 11. Drive Pump 1 Hyd. Hose Reel (A Port)                 | 22. 5 Section Valve* Supply Hyd. Hose Reel  |
|  | 23. Charge VFD Controller                   |

\* 5 section valve functions - Pipe Clamp, Elevators, Winch and Auxiliary Hydraulics

## POWER PACK CONTROL PANEL

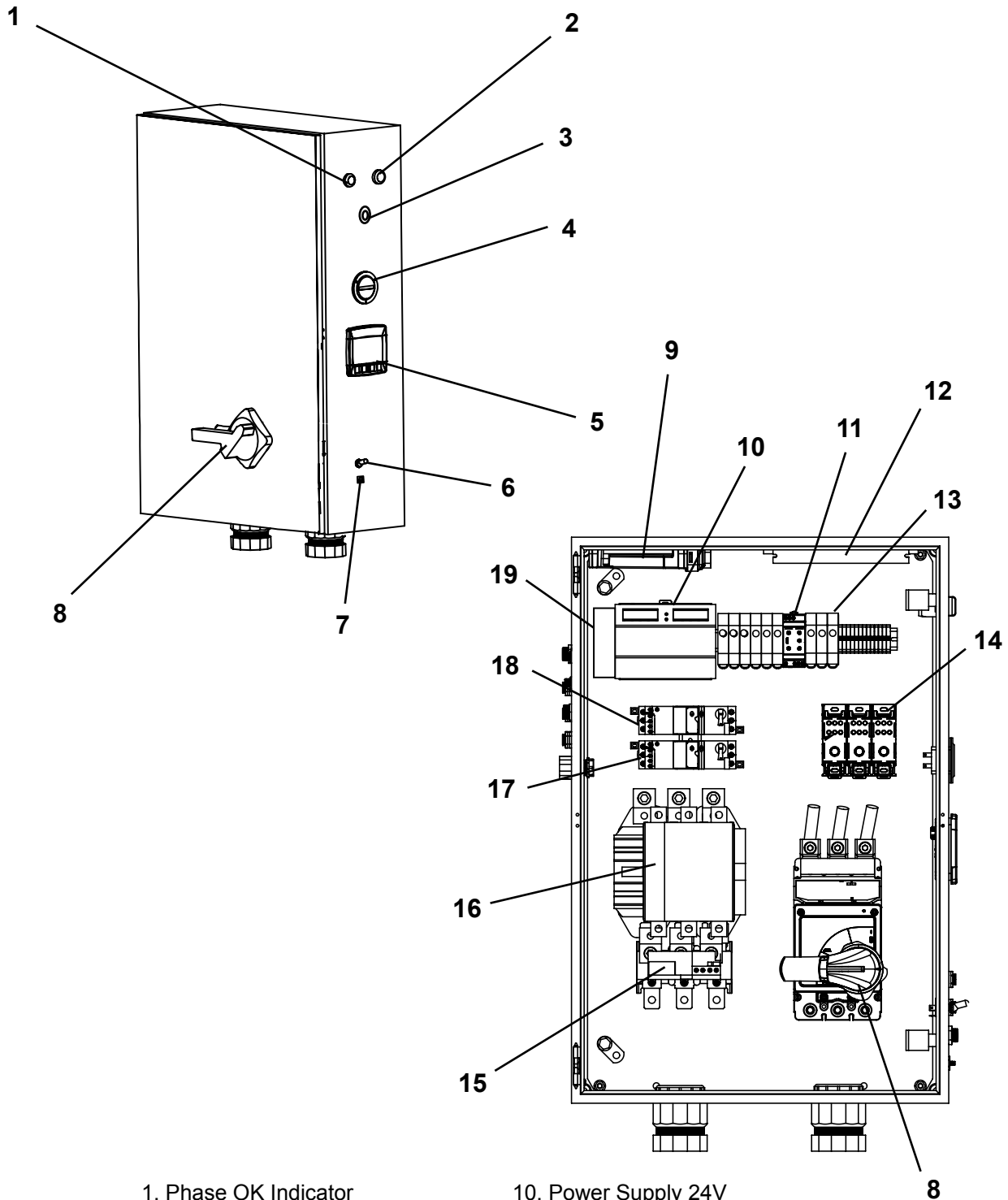

1. Phase OK Indicator
2. Phase Error Indicator
3. Emergency Stop Button
4. Hourmeter
5. Diagnostic Display/Data Logger
6. Transfer Pump Switch
7. CANbus Port
8. Main Power Disconnect Switch
9. Controller

10. Power Supply 24V
11. Phase Monitor
12. 12V DC Converter (for Oil Transfer Pump)
13. Fuses
14. Power Distribution Block
15. Overload Relay
16. Contactor 166 HP
17. Motor Starter
18. Motor Starter
19. TosiBox Data Modem

---

## POWER PACK PRESSURE GAUGE PANEL

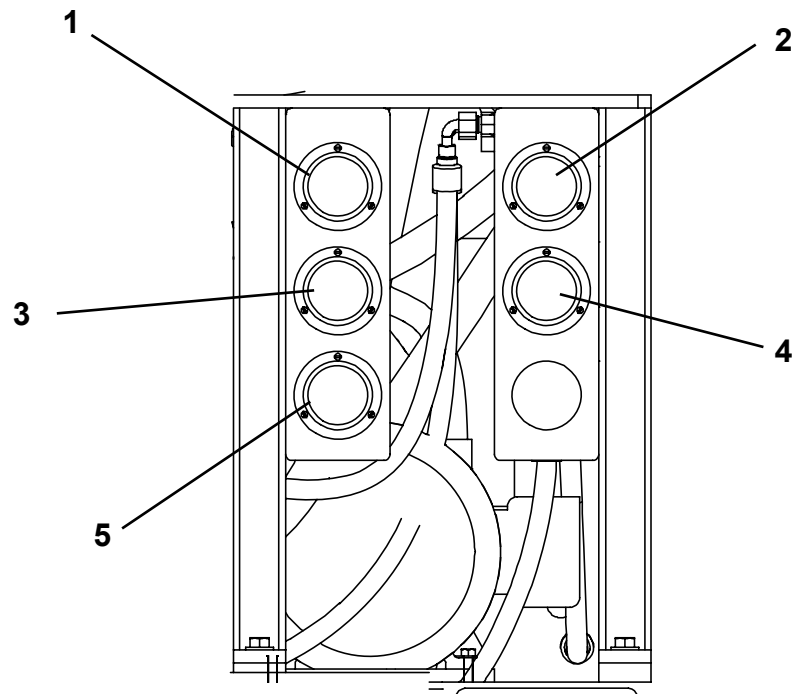

1. Drive Pump 1 (Port B) Pressure
2. Drive Pump 2 (Port A) Pressure
3. Drive Pump 1 (Port A) Pressure
4. Drive Pump 2 (Port B) Pressure
5. Load Sense Pressure

## **NOTES**

# Controls & Instruments

## EMERGENCY STOP (E-STOP)

The Emergency Stop buttons on the slipliner wireless remote pendant (A) and the Power Pack control panel (B) will stop the electrical motor rotation, control system functions and hydraulic power.

The button functions as follows.

- STOP - Push button IN
- Power for Start Circuit - Pull button OUT

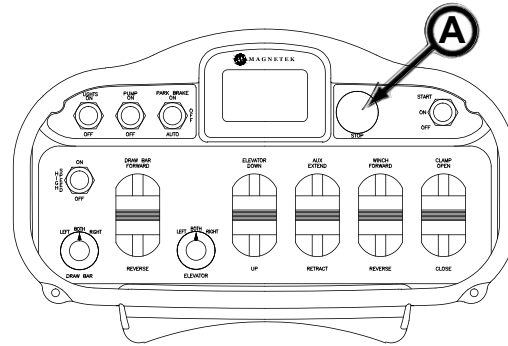

*Sliplining Wireless Remote Pendant E-Stop Button*

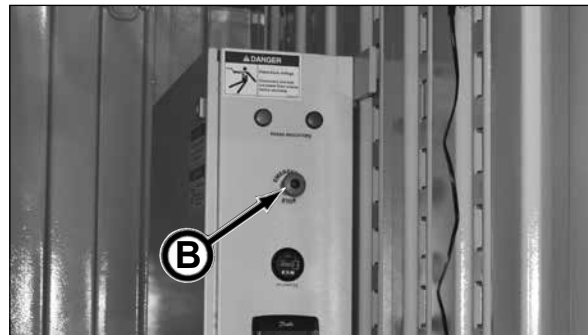

*Power Pack E-Stop Button*

## POWER PHASE INDICATORS

The input power on the power pack is monitored for proper three phase electrical power. The green Phase OK indicator must be illuminated before operating equipment.

**⚠ DANGER** Failure to lockout tagout power before servicing will cause severe personal injury or death.

LOCKOUT, TAGOUT main power supply before servicing. Electrical repairs must be performed only by a certified electrician.

Any electrical work completed on the power pack must be performed by a certified electrician.

**IMPORTANT: If the red Phase Error indicator is illuminated, the power pack starting is disabled. This starting interlock will prevent the components from running backwards which would result in damage.**

The input power is monitored for proper three phase electrical power.

If the green Phase OK indicator (C) is illuminated, this indicates that the external power source phase power is installed correctly and the main power can be turned on.

If the red Phase Error indicator (D) is illuminated, this indicates that the external power source is installed incorrectly. Lockout tagout all power before disconnecting power lead cables. Have a certified electrician reverse the two generator electrical phase conductors on the power circuit and recheck phase power.

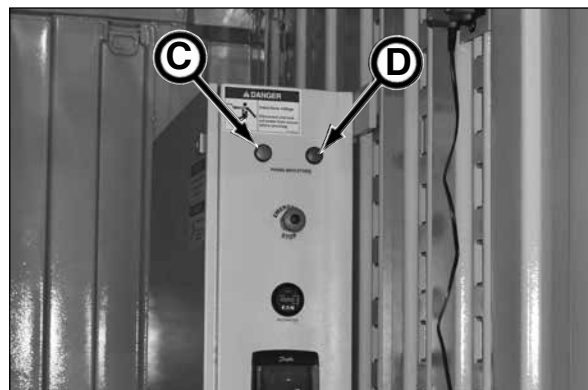

## POWER PACK CONTROLS

The Power Pack provides hydraulic power for the sliplining frame. The one 166 HP electric motor drives one independent load sensing, variable volume, and torque limiting piston pump and two hydrostatic pumps.

The hydraulic hoses are stored on hose reels for ease of routing hoses to sliplining frame. The hoses are connected to the sliplining connections as follows:

- A – Motor Case Drain Hyd. Hose Connection
- B – 5 Section Valve\* Return Hyd. Hose Connection
- C – 5 Section Valve\* Supply Hyd. Hose Connection
- D – Drive Pump 1 Hyd. Hose Connection (B Port)
- E – Drive Pump 1 Hyd. Hose Connection (A Port)
- F – Load Sense Hyd. Hose Connection
- G – Drive Pump 2 Hyd. Hose Connection (B Port)
- H – High Speed Shift/Brake Supply Hose Connection
- I – Drive Pump 2 Hyd. Hose Connection (A Port)
- J – High Speed Shift Brake Return Hose Reel

\* 5 section valve controls the Pipe Clamp, Elevators (2), Winch and Auxiliary hydraulic functions.

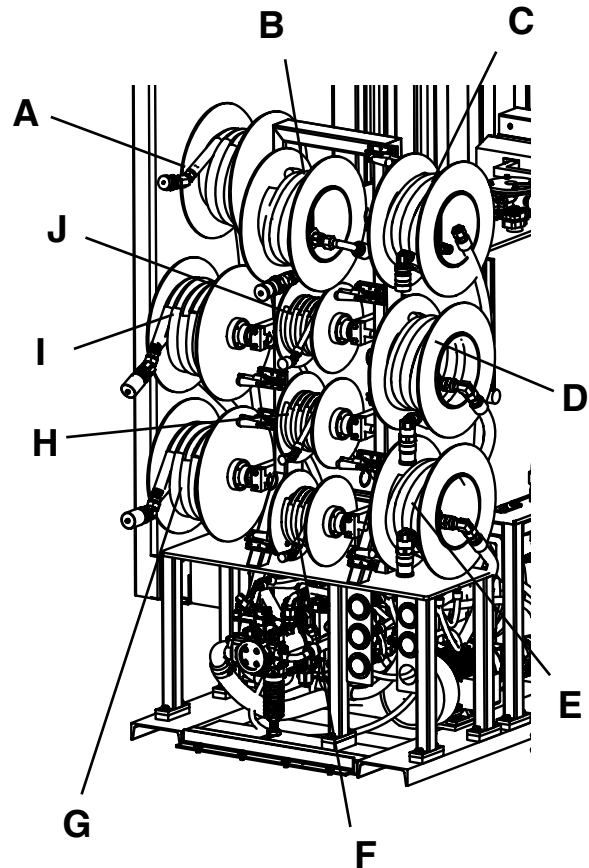

### Hydraulic Pressure Gauges

Use the pressure gauges to monitor the sliplining pressures:

- K – Drive Pump 1 (B Port) Pressure
- L – Drive Pump 2 (A Port) Pressure
- M – Drive Pump 2 (B Port) Pressure
- N – Load Sense Pressure
- O – Drive Pump 1 (A Port) Pressure

Drive Pump Pressures: 37 gpm @ 4,250 psi

Load Sense Pressure: 21 gpm @ 2,000 psi

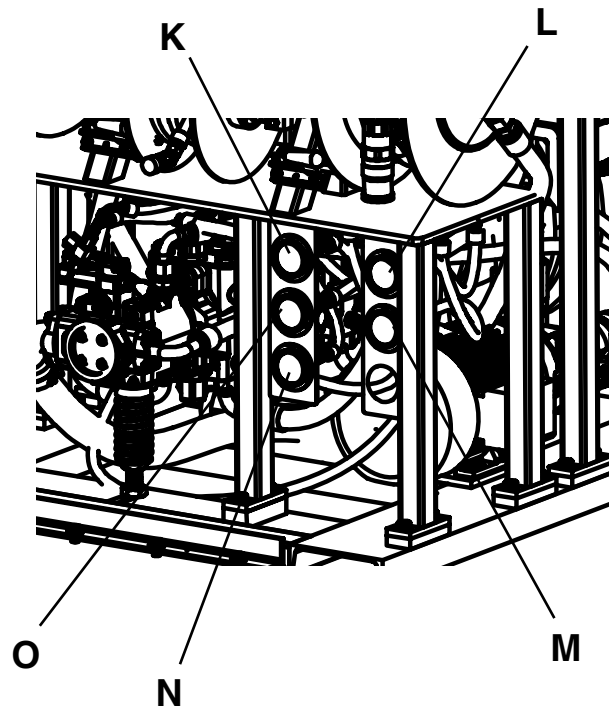

**POWER PACK CONTROLS (continued)**

**Diagnostic Display (A)**

Diagnostic display for troubleshooting, calibration, inputs, outputs, fault monitors and lever travel adjustment controls.

**Oil Transfer Pump Switch (B)**

Turn switch ON to pump hydraulic oil into the hydraulic reservoir.

**CANbus Port (C)**

Diagnostic port.

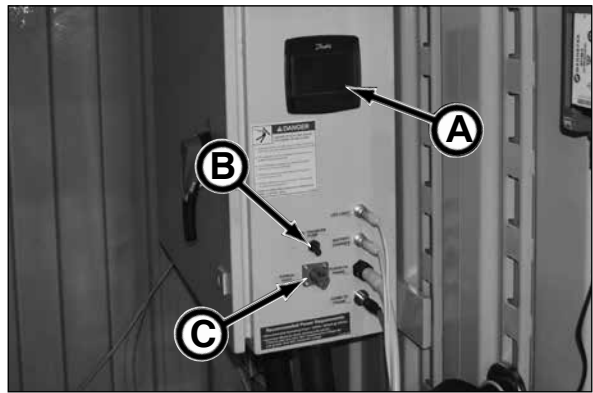

**Hydraulic Return Filter Indicators (D)**

To prevent under or over servicing of the hydraulic filter elements, filter indicators have been installed in the Power Pack.

The green OK zone indicates that the filter is functioning properly. The yellow zone indicates that the filter will soon require replacement.

Replace return filter when the needle on the gauge is in the red CHANGE zone (see 41. Check Hydraulic Filter Indicators in Section 9, Periodic Maintenance section).

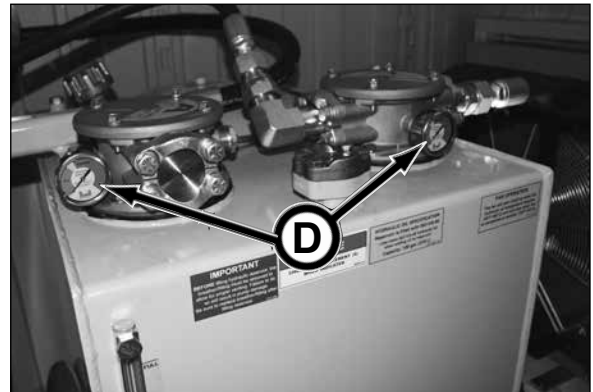

**Emergency Stop (E)**

The Emergency Stop button (E) is located on the side of the control panel.

Push Emergency Stop button IN to stop all electrical and hydraulic functions.

The button will illuminate when it is pulled OUT.

**NOTICE** All emergency stop button must be pulled out for motor to start.

**Battery Charger (F)**

Battery charger for charging wireless remote pendant batteries. Charging is only for recharging the wireless remote pendant NiMH battery packs. DO NOT attempt to charge AA battery packs.

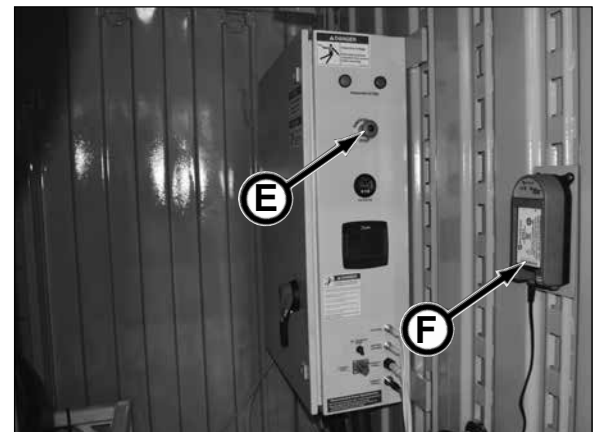

**Hourmeter (G)**

The power pack is equipped with an hourmeter (G) on the main disconnect panel.

The hourmeter displays the operating hours in full hours and 1/10ths hours of the motor and should be used as a guide for scheduling periodic maintenance.

Time accumulates when pump is running.

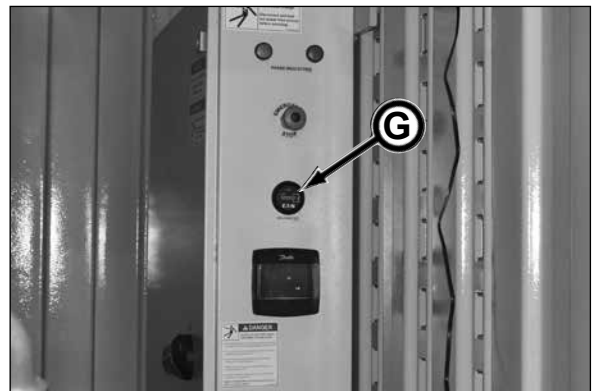

## WIRELESS REMOTE PENDANT

The wireless remote pendant allow the operator in the starting shaft to control the power pack for the hydraulic and electrical operation of the sliplining systems.

All lever controls are proportional; the more the lever is moved from the center or neutral position, the faster the component will move.

### **DRAWBAR DRIVE MOTOR SYSTEM CONTROL (A)**

With the thrust ring mounted to the drawbar, the drawbar/thrust ring is the sliplining jacking (thrust) system. The drawbar can be controlled with both left and right motors (typical thrust operation) or independently with **positioning switch (B)** for repositioning drawbar to the stops or lining up the thrust ring to the pipe sections.

The drive motors are equipped with a brake system using **brake switch (C)**. The drive motor brakes are normally on. In Auto mode, the brake will automatically release when the drawbar control is actuated. Or the brake can be used manually in the on or off position.

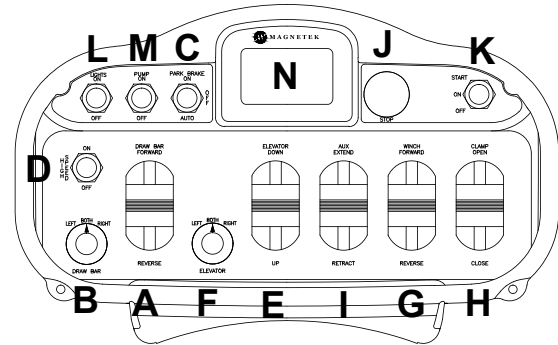

The drive motors are also equipped with a **two speed control (D)**:

Low Speed ..... 11 ft per min.  
High Speed ..... 22 ft per min.

### **ELEVATOR SYSTEM CONTROL (E)**

The elevator system is used for positioning the new pipe in the shaft to the thrust ring and pipe string. The elevators also retain the pipe in position from movement until the thrusting system is in place.

Use **positioning switch (F)** as needed to adjust pipe position; Dual, Left or Right. The left or right position may need to be used to even the lifting action.

### **WINCH CONTROL (G)**

The winch retains the pipe string from flowing away from the jacking frame with the flowing forces of the fluid in the pipe line.

### **PIPE CLAMP CONTROL (H)**

The pipe clamp control will grip the pipe to prevent the pipe line from flowing back into the frame with the flowing fluid. The control regulates the cylinder attached to the pipe shoe.

### **AUXILIARY CONTROL (I)**

Available for hydraulic equipment external to the Akkerman equipment (10 gpm @ 3,000 psi).

### **E-STOP BUTTON (J)**

The Emergency Stop (E-Stop) button will stop the electrical motor rotation and hydraulic power.

The button functions as follows:

STOP - Push Button IN  
Power for Start - Pull Button OUT  
Circuit

### **START ON/OFF & PENDANT ORIENTATION SWITCH (K)**

The start switch activates/deactivates the power to the controller. This switch also controls the pendant orientation switch; changes the drive direction (forward - reverse) on the pendant to match the direction of the pushing of pipe.

### **LIGHT SWITCH (L)**

Flip light switch to turn the power pack lights ON or OFF. The light assemblies are magnetically mounted therefore they can be moved to desired location.

### **PUMP SWITCH (M)**

The pump switch powers the power pack main hydraulic pump ON/OFF. The power pack must be powered on for this switch to function.

### **LCD DISPLAY (N)**

Machine status information such as jacking tons, load sense pressure, hydraulic oil temperature will be displayed.

### LCD DISPLAY - DEFAULT OPERATION SCREEN

Once the wireless remote pendant is online, the default operation screen appears on the LCD display to provide the operator important machine status information.

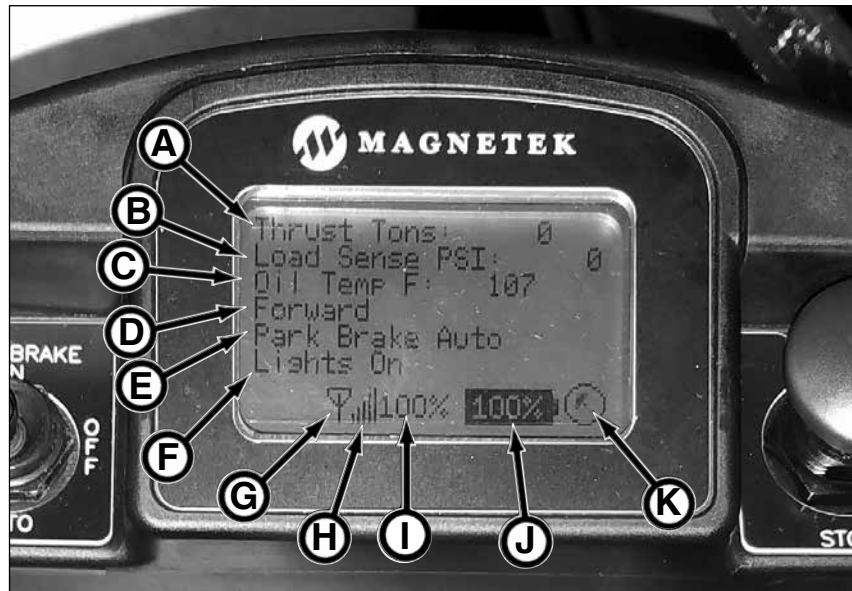

**Thrust Tons (A):** displays the calculated tons of thrust that is being applied to the pipe by the sliplining frame.

**Load Sense PSI (B):** displays the load sense pump pressure of the 5 section valve functions (elevators, pipe clamp, winch and auxiliary).

**Oil Temp F (C):** displays the temperature of the hydraulic oil reservoir in degrees Fahrenheit.

**Forward/Reverse (D):** displays the pendant travel orientation. The drive direction on the pendant can be changed to match the direction of the pushing pipe.

Once the pendant is started (refer to Wireless Remote Pendant Start Up Procedure in section 6, Operation), the travel orientation can be toggled between Forward and Reverse orientation by flipping the Start switch momentarily up to the Start position and hold switch for five seconds for it to change to desired direction.

**Park Brake Auto (E):** this field will show control usage (functions on/off, lever stroke %) and will change depending on the use of any of the controls and levers on the pendant.

**Lights On (F):** this field will show control usage (functions on/off, lever stroke %, fault) and will change depending on the use of any of the controls and levers on the pendant.

**Wireless Signal Strength Indicators:** displays the wireless signal in three modes:

- Wireless Symbol (G)** indicating the pendant is receiving a wireless signal from the receiver.
- Wireless Signal Bar Meter (H)** provides a visual indicator of the general strength of the signal.
- Wireless Signal (I)** is the actual wireless signal power strength from the receiver.

**Pendant Battery Level Remaining (Approx.) (J):** displays the approximate battery level of the pendant in both graphical representation and numeric value.

**Remote Program Status Indicator (K):** displays the status of the remote wireless pendant program.

- Program is operational with a spinning program indicator
- Program is not operational with a static program indicator

## **NOTES**

# Pre-Start Inspection

## **⚠ WARNING**

Do not operate this equipment until you read, study, and understand this manual. A daily inspection of the equipment must be performed to prevent severe personal injury or death and equipment damage.

**The contractor is fully responsible for the safety of all personnel on the job site.** Check with the contractor that all site preparation requirements are in place. Be sure to comply with all OSHA regulations, such as: an active safety program is in practice, a confined space permit (if needed) is issued, personal protective equipment is being worn, monitoring of combustible and toxic gases including the depletion of oxygen; flammable, combustible, and hazardous materials are properly stored; and a lockout/tagout procedure is in place.

Use the following checklist ✓ as a guide for your daily pre-start inspection.

	1. Use "ONE-CALL" notification to check for buried utility lines prior to tunneling.
	2. Check the excavated launch and reception shafts for proper shoring or bracing to prevent slides or cave-ins.
	3. Thoroughly clean equipment of mud and dirt.
	4. Check condition of personal protective equipment. Replace equipment if defective.
	5. Contractor is responsible for all personnel to wear proper protective equipment on the job site.
	6. Remove combustible or flammable materials from equipment. Store materials properly.
	7. Test <u>ALL</u> Emergency Stop buttons for proper operation at the start of each shift.
	8. Test air monitoring and ventilation detectors for proper operation. Tunnel must be ventilated with fresh air.
	9. Thoroughly inspect all equipment for damage. Repair or replace before operating.
	10. Be sure all covers and guards are in place before operation.
	11. Check for loose or missing hardware. Replace damaged or missing hardware.
	12. Check for worn, loose, or damaged wire connections. Repair or replace wiring.
	13. Tighten loose clamps or fittings.
	14. Check electrical cables for frayed or worn insulation or wiring. Replace damaged or worn harnesses.
	15. Check for fluid leaks. Repair leak or replace components.
	16. Keep job site clean and organized.
	17. Perform all lubrication and maintenance procedures. Refer to Section 9, Periodic Maintenance.
	18. Test each function and control to ensure correct operation.
	19. Check hydraulic hoses and lines for leaks, wear and/or damage. Replace any defective hoses and/or lines.
	20. Check oil level in hydraulic oil reservoirs. Add as needed.
	21. Be sure the green Phase OK Indicator light is illuminated before starting electrical components.
	22. Check cable for continuity and shorting before each use. Constantly check cables for damage.
	23. Decals must be clean and legible.

## **NOTES**

# Operation

## OPERATING GUIDELINES

**⚠ WARNING** Do not operate this equipment until you read, study, and understand this manual. Failure to do so, could result in severe personal injury or death.

1. Before operating, read and understand the Safety, Pre-Start Inspection, Operation and Maintenance sections.
2. Do not operate this equipment while under the influence of alcohol, drugs, or medication.
3. Follow all Federal, State, and Local safety regulations and procedures.
4. Be sure OSHA prescribed safety protective equipment is being worn by all personnel.
5. Be sure the area is safe for operation. Keep worksite clean and orderly.
6. NEVER operate equipment if it has been engulfed with water. Contact your Akkerman Aftermarket Support representative for proper procedures on how to restore equipment for operation.
7. Have fully charged fire extinguishers on the job site at all times.
8. Before operating, inspect all equipment and repair equipment problems. Check hoses for cuts or bulges. Replace worn or damaged hoses.
9. Be sure the excavated launch and reception shafts are properly shored or braced to prevent slides or cave-ins.
10. Test air monitoring and ventilation detectors for proper operation. Never enter a shaft or tunnel without properly functioning detectors. Shaft and tunnel must be well ventilated.
11. A fully trained and qualified signal person must direct the excavator or crane operator when lifting and lowering equipment into the launch or reception shafts.
12. Never walk or work under any part of the excavator or crane and suspended loads.
13. Test each function and control to make sure they work properly.
14. Lock out/tag out electrical power at the source (generator) before servicing electrical components.
15. Do not make any non-authorized modifications to any Akkerman products. Doing so could cause structural failure and will void the warranty.
16. Check shields and guards. All must be in place and undamaged.
17. Test all Emergency Stop circuits for proper operation at the start of each shift.
18. Before starting equipment, walk completely around all machines and equipment. Let all job site personnel that you are starting up the equipment. Do not start until all unauthorized personnel are clear of the equipment.
19. Check cable for continuity and shorting before each use. Do not pull or strain cables; doing so will result in damage.
20. Pressure peaks cause hoses to jump without notice. Keep all personnel away from hoses during operation of equipment.
21. After start-up, observe all gauges, controls and warning devices to assure they are functioning properly and their readings are within the operating range.
22. Perform lock out/tag out procedure on all equipment and power source before performing maintenance.
23. Constantly monitor electrical cables during jacking process to prevent cutting or stretching of any electrical cables. Contact with severed electrical cables WILL cause severe injury or death.

## SYSTEM OVERVIEW

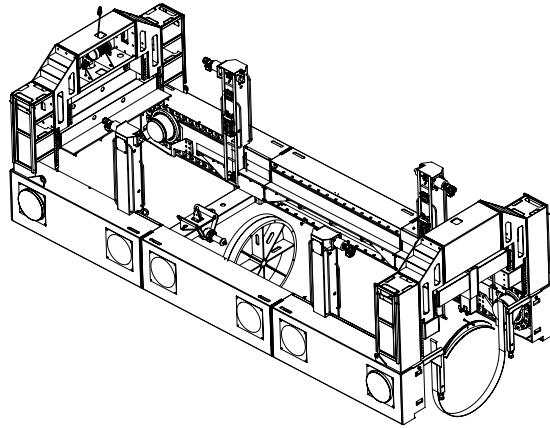

The Akkerman SLS 50/100 Ton Sliplining System is utilized for rehabilitation of deteriorating sewer lines. The machine is utilized for insertion of a pipe string into an existing live sewer line. Once the shaft is constructed, the top half of the existing pipe is removed at the spring line. The contractor then takes measures to insure that the inside of the existing pipe has sufficient clearance to receive the new pipe. Once this is complete, the Akkerman equipment is lowered and anchored into the starting shaft. The pipe is positioned in the elevator system which then controls the position of the pipe until the actual jacking is started. The elevator lowers the pipe into position, and retains it from movement due to the flow forces of the fluid.

Once the pipe is positioned, the thrusting system is actuated to push the pipe axially into position. A retention winch is provided to retain the pipe string from flowing away from the jacking frame due to the flow forces of the fluid. A gripping system, pipe clamp, is provided and can be positioned at each end of the pipe insertion frame to prevent the pipe string from flowing back into the frame due to flow forces of the fluid. This is necessary when setting in a new pipe for installation.

The thrust force of the system is provided by triple reduction planetary gearboxes with an interconnected roller chain mechanism. The gearboxes in a dual drive are positioned at one end of the pipe insertion frame, one on each side of the pipe. Two loops of chain, one for each gearbox, are routed over the gearboxes and over a mating idler sprocket at the opposite end of the pipe insertion. A drawbar is connected to the bottom section of chain on each side of the pipe. A pipe thrust adapter ring is mounted on the drawbar to engage the pipe section. As the gearboxes are simultaneously rotated, the pipe section can be thrust in either direction.

The dual drive thrusting capacity is 50 tons. The thrusting force is provided by two roller chain drive systems, one on each side of the pipe, each generating 25 tons of force.

The planetary gearboxes are operating at the manufacturer's continuous torque capacity rating at the 50 ton thrusting force. The thrusting rate of the drawbar is 22 feet per minute, with a gearbox output speed of 2.7 rpm.

The quad drive thrusting capacity is 100 tons. The thrusting force is provided by two roller chain drive systems, one on each side of the pipe, each generating 50 tons of force. The planetary gearboxes are operating at the manufacturer's continuous torque capacity rating at the 100 ton thrusting force. The thrusting rate of the system is 11 feet per minute, with a gearbox output speed of 1.35 rpm.

The roller chain is 6 inch pitch with a average tensile strength of 225 tons. The design factor on the chain average tensile strength is 9 to 1. The sprockets on the planetary gearbox and idler sprocket are both 15 tooth, with a pitch diameter of 28.8 inches.

The power to the system is provided by a 166 HP electric motor that powers a triple pump located adjacent to the pipe insertion frame above ground. The motor drives a dual hydrostatic piston pump and a load sense pump. The dual piston pump is the source for the hydraulic piston motors integral to the planetary gearboxes. The gear pump is the source for the auxiliary functions. The auxiliary functions of the frame include the four elevators, pipe clamp, winch, and one auxiliary function for future use.

## RECOMMENDED TOOLS & EQUIPMENT

Below is a list of tools and equipment for most complex technical construction operations. Financial resources and equipment availability are as much of a deciding factor as immediate job site requirements in determining what items should be on hand. This list contains many items, some of which may only be needed in special situations.

1. Safety equipment, first-aid kit, fire extinguishers, and stokes-type stretcher.
2. Any other required safety gear, such as air monitoring or gas detection systems.
3. Ventilation fan(s) and ducting.
4. Communications equipment and good quality flashlights.
5. Generator sized for the project's power requirements including an adequate fuel supply for the generator's minimum period of operation.
6. A crane sized to project requirements.
7. Adequate pumping capacity for launch and reception shaft sump, and process water overflow, potential storm event inflow, trash pump, and hoses.
8. Adequate job site lighting, crew safety vests, and traffic control devices/signage, and barricades.
9. Wash down hose and spray nozzle.
10. Measuring and surveying equipment; including sight level or theodolite, laser levels, plumb-bobs, string lines and 100' tape measure.
11. Secure tool and equipment storage.
12. Rubber-tired front-end loader with bucket and forks.
13. Skidsteer loader.
14. Shovels, rakes, and brooms.
15. Bullfloat and trowels.
16. Concrete bucket, tremie hose and hopper.
17. Carpentry tools including circular saw, sawzall, extension cords, and cordless drill w/bits, and basic hand tools.
18. Hammer drill and masonry bits, small "rivet buster" type jackhammer, chisels.
19. Sledgehammer(s), pry and crowbars of all sizes, spud wrenches, and pick-bars.
20. Various sizes hydraulic bottle jack(s), railroad or house type jacks, porta-power hydraulic jack cylinder kit.
21. Log chains, shackles and clevis'.
22. Chain or cable-type "come-alongs."
23. Arc welder and cutting torch rigs, eye shields and required protective gear.
24. Disc and mini-disc grinders, and extra discs.
25. Mechanic's tools, including but not limited to; wrenches, sockets, allen wrenches, torque wrenches, pliers, screwdrivers, hammers, etc.
26. Grease gun.
27. Electrician's tools, including test meters, voltage indicator, ground fault indicator, and specialty hand tools.
28. Pipe wrenches, water pump pliers, pump packing removal kit.

## SITE PLANNING

It is important to carefully review the site and make sure that it is arranged in the most effective manner possible. Here is a list of equipment and site considerations that are typically needed for a sliplining project.

### *Equipment:*

- |                                   |                            |                                |
|-----------------------------------|----------------------------|--------------------------------|
| - Crane                           | - Fork Lift                | - Storage Container With Tools |
| - Generator 400V 3 Phase          | - Portable Welders / Torch | - Small Generator              |
| - Portable Toilet                 | - Spoil Removal Truck      | - Floor Pads (Plates)          |
| - Pipe Joint Cushions (if needed) |                            |                                |

### *Other site considerations:*

- |  |                         |                               |
|--|-------------------------|-------------------------------|
| - Spoil Removal Truck Access               | - Pipe Unloading area   | - Fresh Water Supply          |
| - Launch Shaft Size                        | - Hose Interconnections | - Electrical Interconnections |
| - Walkways                                 | - Pipe Staging Area     | - Jacking Shaft Access Area   |
| - Any Traffic or Other Physical Restraints |                         | - Lighting                    |

## SITE PREPARATION

1. The contractor is fully responsible for the design and construction of the OSHA required launch and reception shafts. Consult your civil and structural engineers for the design, structural and thrust loads of the shafts
2. After the soil analysis, shaft layout design, and survey are complete, construct the launch and reception shafts. Be sure the shafts will be well drained and use proper shoring, bracing or trench box in accordance with your local, state, and federal regulations. Be sure an appropriate thrust block is constructed in the design to handle the thrust loading.
3. When cutting the existing pipe, the horizontal cut must be below the pipe centerline.
4. Build the shaft floor with a solid base (such as concrete) suitable for the weight of the sliplining system and pipe on both sides of the existing pipe three inches below the pipe centerline. Consult your civil and structural engineers for your shaft floor requirements.
5. Construct a concrete thrust block to withstand the applied load. A structural engineer must be consulted on the design of this block.
6. Prepare a firm, level surface for the power pack a safe distance from the launch shaft.
7. Before lowering sliplining frame into the launch shaft, the pipe must be inspected, cleaned with a steel cleaning brush and prepared using a testing mandrel or prover (see inset) to ensure the new pipe can be inserted into the existing pipe without blockage.
8. It is highly recommended that before lowering the sliplining frame into the launch shaft, connect the power pack to the equipment and test all hydraulic and electrical functions. Run the drive system under no load from one end of travel to the other end to confirm there are no obstructions while moving in the frame. Also, check the speed matching of the drive motors (refer to Adjusting Drive Motor Speed Matching in this section).
9. Disconnect the power pack from the sliplining frame.

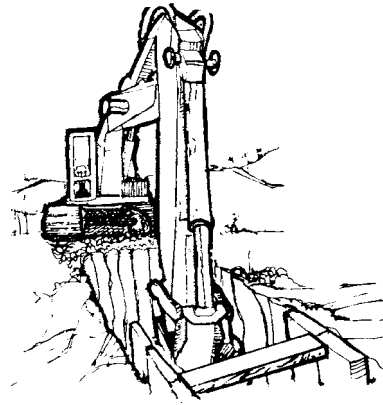

*AEM is the original author and publisher of the above illustration*



*(continued on next page)*

**⚠ WARNING** Suspended loads may fall and cause severe injury or death. Do not allow anyone to enter area under or around a suspended load.

**NOTICE** Be sure the crane or excavator and all lifting equipment is rated to lift load. Remember, you may be able to lift the load in close at ground level, but as the load radius and elevation change, the lifting capacity of the crane or excavator or other lifting equipment will decrease.

10. Connect lifting sling or other lifting device to the four lifting eyes on the sliplining frame.
11. Lower frame into launch shaft against the thrust or reaction block, centered over existing pipe opening. Anchor the frame to the shaft.
12. Install drawbar to drawbar connection on chain with four drawbar mounting pins.
13. Mount properly sized thrust ring to drawbar connection shaft with retaining collar, 1" lock washer and one 1" hex head bolt (2.5" or 4.5" long depending on size of thrust ring).
14. Install pipe clamp band to rotating spacer on pipe clamp assembly with two 5/8 UNC x 8" socket head cap screws.

**⚠ WARNING** Do not position the Power Pack near the edge of the launch shaft where the ground may be unstable and cause a slide or cave-in. Doing so could cause severe injury or death.

15. Place the power pack on the firm, level surface prepared in step 6.
16. Connect the power pack hydraulic hoses to the sliplining frame hydraulic hose quick disconnects (refer to Connecting Hydraulic Hoses To Sliplining Frame in this section).
17. Connect electrical cables from the power pack electrical connections Power To Frame and Comm To Frame to the sliplining frame connections (refer to Connecting Power Pack Electrical Connections in this section).

*(continued on next page)*

050163\_slipliningssystem-om

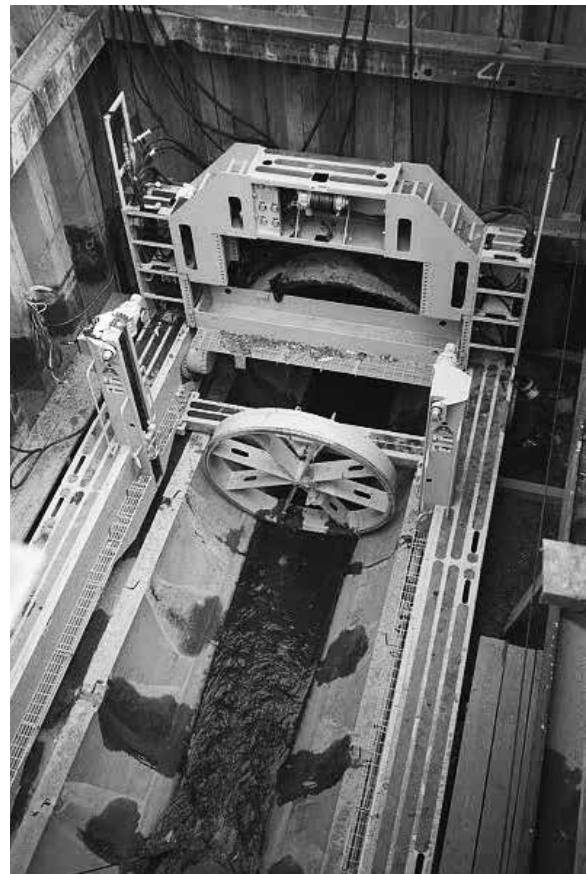

**⚠ DANGER** Improper grounding can result in equipment damage or electrical shock, causing severe injury or death.

**⚠ DANGER** Ground connection **MUST** be connected prior to connecting incoming power.

18. **Properly ground the generator (or other power sources) and power pack.**



**⚠ DANGER** Hazardous voltage. Disconnect and lock out tag out power from source before attempting to install electrical connections.

19. Connect and secure power cables from generator to power pack (refer to Connecting Power Pack Electrical Connections in this section).

20. Proceed to Checkout Equipment Prior Start-Up in this section.

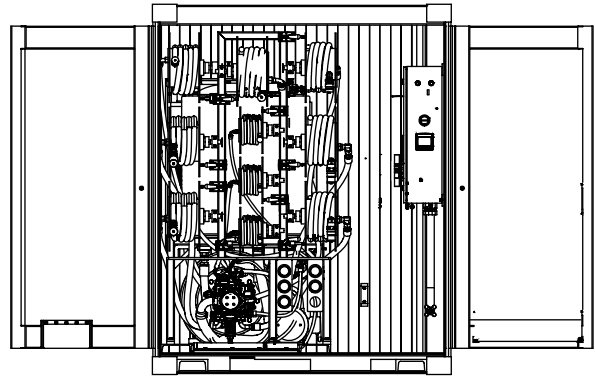

## CONNECTING POWER PACK ELECTRICAL CONNECTIONS

**⚠ DANGER** Hazardous voltage.  
This system is powered by high voltage electricity.

Failure to lockout tagout power before connecting power leads will cause severe personal injury or death.

LOCKOUT, TAGOUT main power supply before connecting power leads or servicing. ONLY a qualified and trained technician can operate this equipment. Electrical connections or repairs must be performed only by a certified electrician.



### MAIN POWER FROM GENERATOR

1. With generator or power source properly ground, connect power pack power cable (A) to the generator power connections.

#### Recommended Power Requirements

- Recommended Operating Power:  
..... 190kW / 235kWA @ 400 VAC
- Generator Minimum Motor Starting kVA (skVA):  
..... 640skVA with less than 35% instantaneous voltage dip and greater than 90% sustained voltage

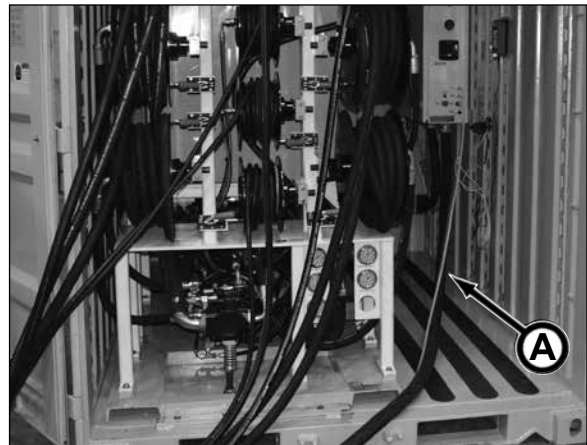

### POWER PACK TO SLIPLINING FRAME

2. Connect cable from Power To Frame (B) and Comm To Frame (C) connections on control panel to electrical harness bulkhead (D) on sliplining frame.
3. Proceed to Checkout Equipment Prior Start-Up in this section.

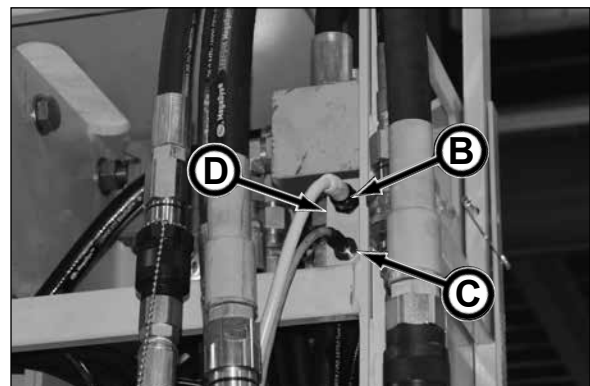
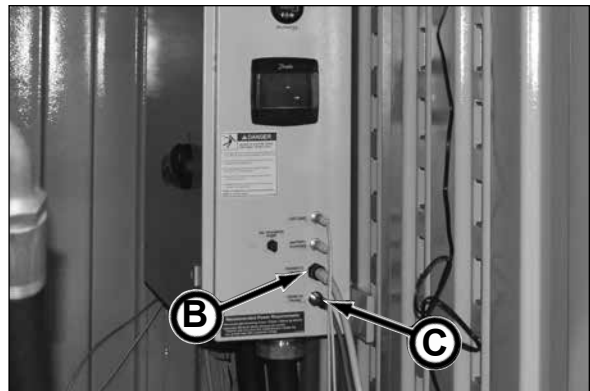

## CONNECTING POWER PACK HYDRAULIC HOSES TO SLIPLINING FRAME

The power pack and sliplining frame have color coded hydraulic hose quick disconnects to make it easier for plumbing the two components together. Connect the power pack hydraulic hose quick disconnects to the sliplining frame manifold hose quick disconnects as follows:

### NOTICE

**NEVER** clamp on the coupler sleeve. This will cause distortion, resulting in coupler damage.

1. There are two types of quick disconnect connectors on the sliplining system. Use the instructions below to properly install the couplers. BEFORE installation, be sure to clean ALL mating surfaces to prevent contamination.

#### • Case Drain Quick Disconnect

### NOTICE

If quick disconnect is not fully locked, valve assembly damage will occur.

#### CONNECT

- a. Rotate main sleeve (A) clockwise (CW) until locking collar (B) snaps against fitting end (C).
- b. Check the locking mechanism, by rotating the main sleeve counterclockwise (CCW). If sleeve rotates, then the locking collar is not properly locked.

#### DISCONNECT

- c. Pull locking cover back and rotate main sleeve counterclockwise (CCW) until coupler is removed.

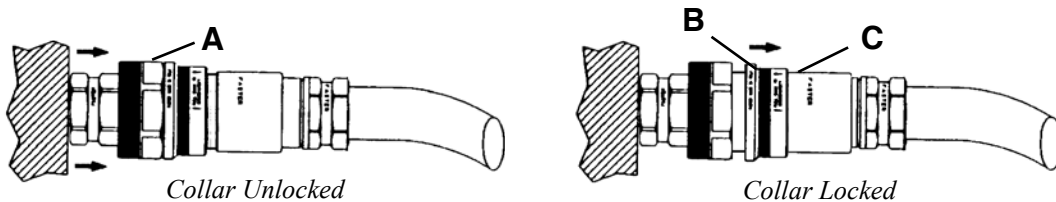

#### • All Other Quick Disconnects

#### CONNECT

- a. Hand tighten coupler by rotating clockwise (CW) until o-ring is no longer visible. If o-ring is visible, the connection is not locked.

#### DISCONNECT

- b. Rotate hose coupler counterclockwise (CCW) until coupler is removed.

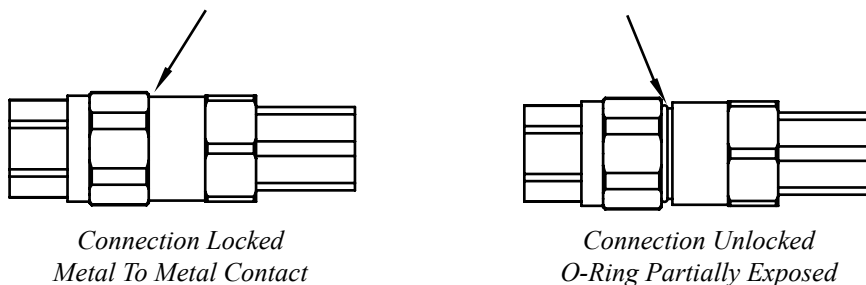

(continued on next page)

2. Using the corresponding letters below, route the hoses from the power pack hose reels to the appropriate sliplining frame manifold quick disconnects as shown in the illustration below. Be sure quick disconnects are properly connected.

**Red Manifold**

- A - High Speed Shift/Brake Supply (HSSBS)
- B - High Speed Shift/Brake Return (HSSBR)
- C - Drive Pump 2 Port B (DP2B)
- D - Drive Pump 2 Port A (DP2A)
- E - Case Drain (CD)

**Blue Manifold**

- F - Drive Pump 1 Port B (DP1B)
- G - Drive Pump 1 Port A (DP1A)
- H - 5 Section Valve Supply (5SVS)
- I - 5 Section Valve Return (5SVR)
- J - Load Sense (LS)

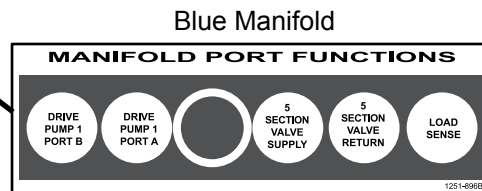
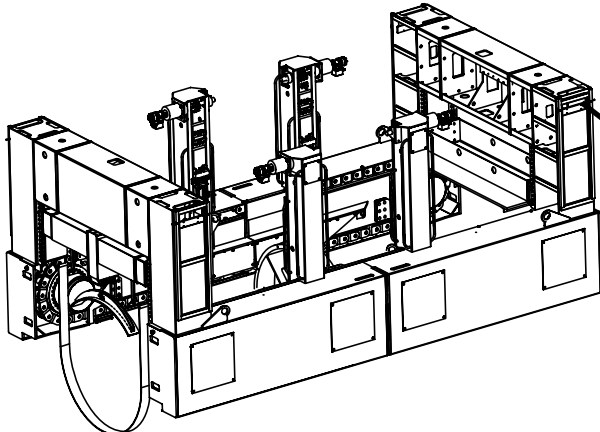
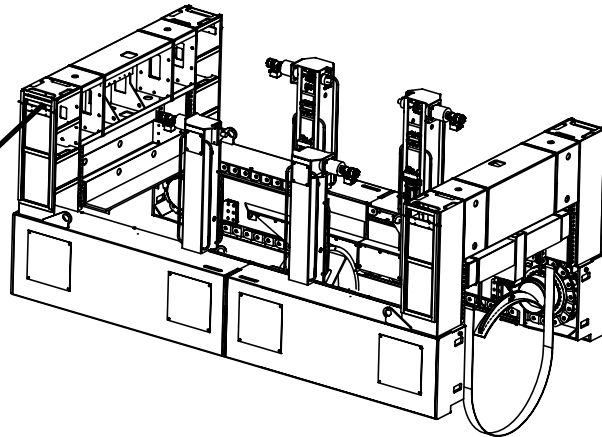
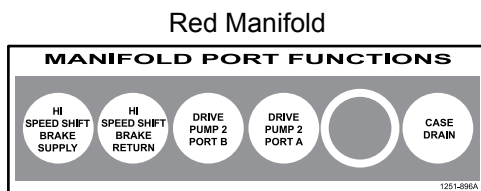
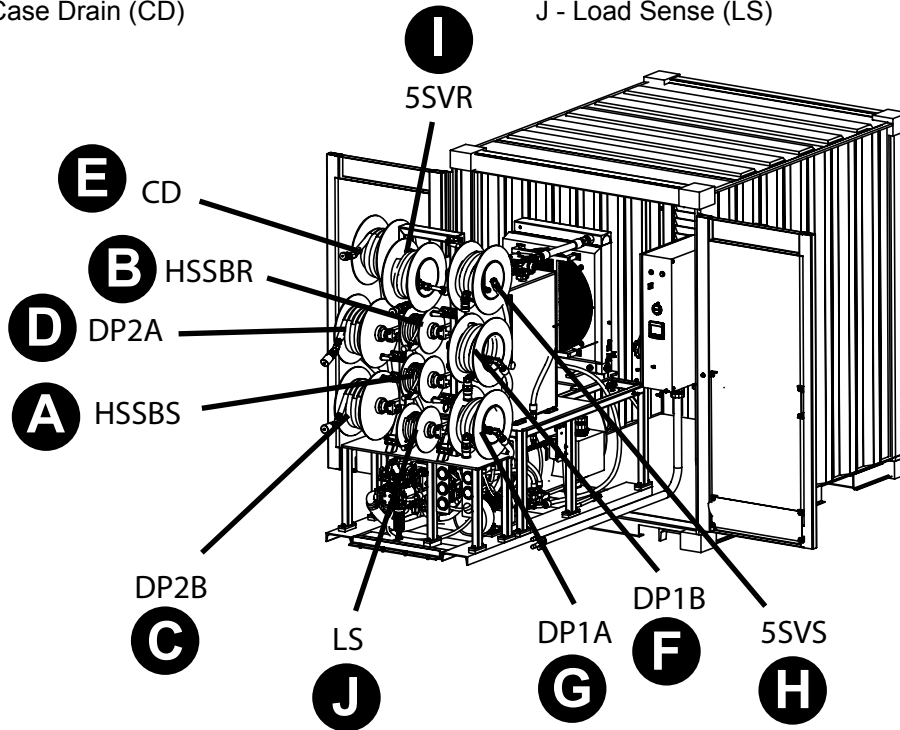

## CHECKOUT EQUIPMENT PRIOR TO START-UP

1. Before checking equipment, the shaft must be properly vented and monitored for accumulation of combustible and toxic gases including the depletion of oxygen.
2. Check the operation of ALL E-Stop buttons before operating sliplining system.
3. All electrical lines and hydraulic hoses must be properly installed and in good working condition.
4. Perform maintenance in Prior To Each Drive Launch in section 9, Periodic Maintenance before operation.
5. Proceed to Remote Pendant/Power Pack Start Up Procedure in this section.

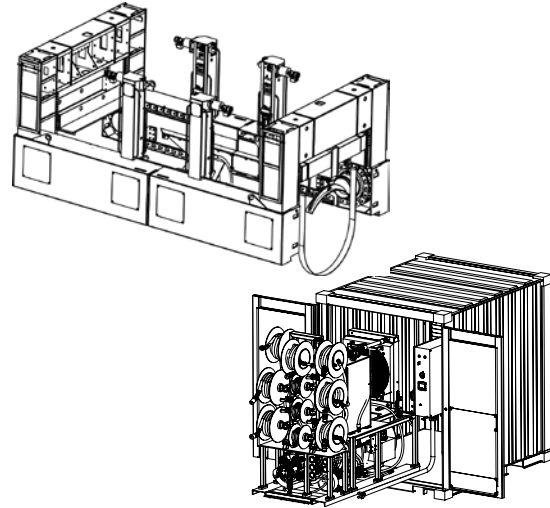

## WIRELESS REMOTE PENDANT START UP PROCEDURE

Once generator power, electrical cables and hydraulic hoses from the power pack to the sliplining frame are properly connected, the wireless remote pendant can be started as follows:

1. With E-Stop buttons (A) pushed in, turn on generator/power source main power to the power pack.
2. Check Phase Indicators (B). If the green Phase OK indicator is illuminated, the external phase power is installed correctly and the power pack main power can be turned on. If the red Phase Error indicator is illuminated, the external power source is installed incorrectly. Lockout tagout all power before disconnecting power lead cables. Have a certified electrician reverse the two generator electrical phase conductors on the power circuit and recheck phase power.

**IMPORTANT: If the red Phase Error indicator is illuminated, the starting is disabled. This starting interlock will prevent the components from running backwards which would result in damage.**

3. With proper phase power, pull out ALL E-Stop buttons (A).
4. Flip main power disconnect switch (C) to the ON position.

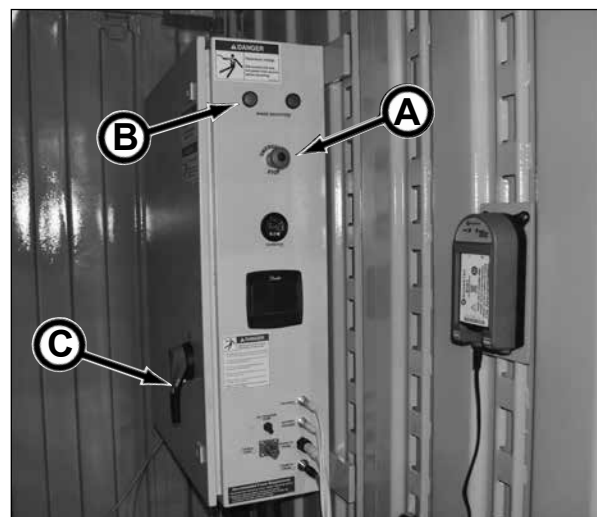

(continued on next page)

5. On the wireless remote pendant, flip the Start switch (A) to the ON position. A system initializing sequence will appear on the LCD display (B). After initializing is complete, the LCD display will show "Rx Offline," indicating the pendant is on but not online.

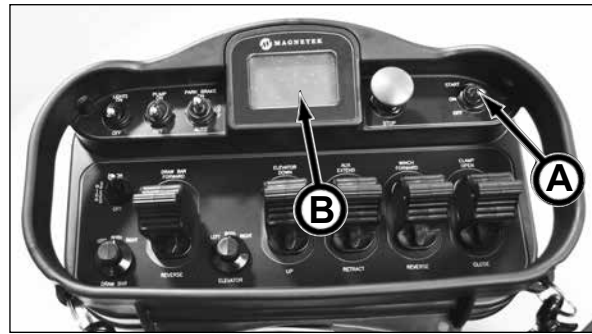

**NOTICE**

When the wireless remote pendant no longer receives a signal, or the pendant batteries are dead, the hydraulic and electrical functions will stop.

6. Once receiver LED (C) on sliplining frame flashes red, momentarily flip Start switch (A) up to the Start position (do not hold switch).

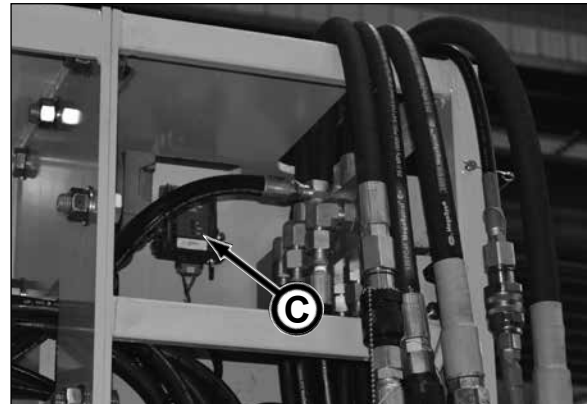

7. The receiver LED (C) will turn green and the default screen (D) is now shown on the LCD display. The wireless remote pendant is now online.
8. Proceed to Power Pack Start Up Procedure in this section to start the power pack functions for the sliplining operations.



**NOTICE**

If the Start switch is in the ON position but the remote pendant is not connected to receiver (sleep mode or screen is off), then the Start switch will need to be switched to OFF and then to the ON position to bring the pendant back online.

## POWER PACK START UP PROCEDURE

1. Start up wireless remote pendant (refer to Wireless Remote Pendant Start Up Procedure in this section).
2. Flip Pump Switch (A) to the ON position. The 166 HP motor and pumps in the power pack will start up.

### NOTICE

If the Pump switch is in the ON position before connecting wireless remote pendant, the remote pendant will connect, but the Pump switch will need to be switched to OFF and then ON for the pump to operate.



3. Check for leaks.
4. Check filter indicators (B). Replace filters as needed.
5. Be sure all air purged from the hydraulic system and check for any leaks.
6. To protect the product pipe, you must be sure the product pipe rating can withstand the thrust pressure of the sliplining system.

### DO NOT BREAK PIPE.

Refer to (in this section):

- Setting Drive Pressure Limit Control

7. Proceed to System Start-Up in this section.

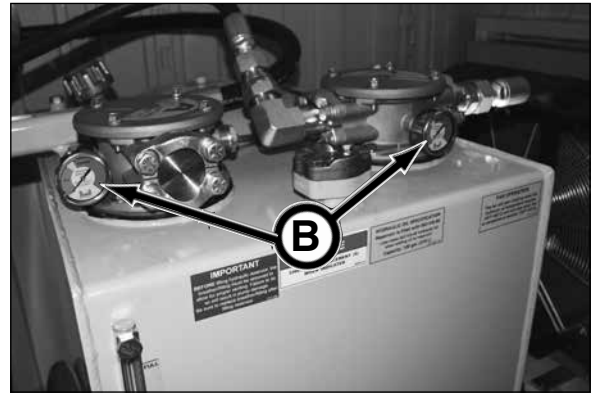

**NOTES**

## SETTING DRIVE PRESSURE LIMIT CONTROL

### NOTICE

To protect the product pipe, you must be sure the product pipe rating can withstand the thrust pressure of the sliplining system. Set the drive pressure limit control to prevent pipe damage. The control can be set from 1,000 psi to 4,250 psi; with an accuracy of 500 psi. To achieve maximum force, set pressure limit to maximum 4,250 psi.

**IMPORTANT:** The force applied values displayed (Thrust Tons Est.) are calculated from pressure readings (pressure transducer data from the pumps). Due to the variables (temperature, viscosity, component wear, etc.) in the mechanical and hydraulic systems, the force calculation displays only theoretical force applied values. Thus the actual jacking thrust may be different than the displayed thrust tons est. values.

1. Check the thrust pressure (tonnage) rating for your product pipe.

### NOTICE

Contact your Akkerman Aftermarket Support representative for the Pressure to Tons Load Conversion chart.

2. On the Diagnostic Display home screen, press CAL button.

3. The Select Calibration screen appears. Press Menu 1 tab for Drive Pressure Limit screen.

4. The Drive Pressure Adjust Password window appears.

*(continued on next page)*

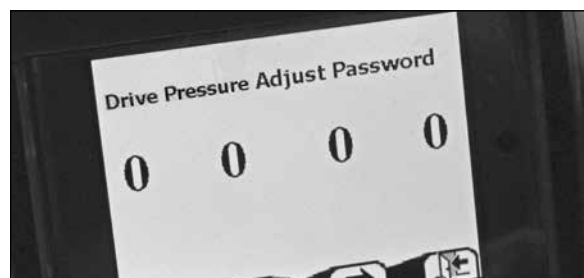
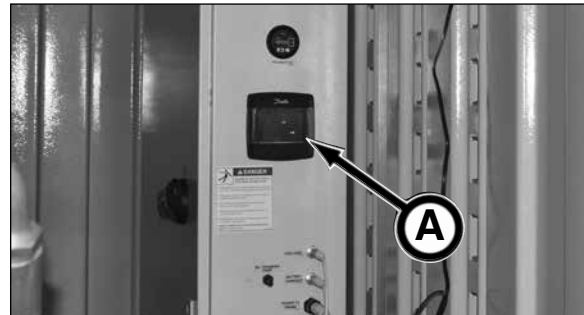

- Using the up, down, and forward arrow buttons, enter the password 3 9 2 1. Press the forward button to enter password.



- If the password is correct, the Drive Pressure Limit window appears.
- Using the arrow buttons, enter the maximum pressure for the product pipe. Once pressure is set, press Home/Back button (A) to return to the home screen.
- The maximum pressure for the product pipe is now set.

**IMPORTANT:** The photo depicts the maximum pressure limit setting for the sliplining system. Be sure to set the pressure setting for your pipe based on the actual pipe rating. Failure to do so will cause pipe damage.



## ADJUSTING DRIVE MOTOR SPEED MATCHING

**IMPORTANT: DO NOT** adjust the drive motor speed matching unless the automatic speed matching becomes out of range or when hydraulic components are replaced.

The Sliplining System is equipped with hydraulic motor speed sensors to keep both Drive 1 and Drive 2 in similar linear speed. The speed sensors are used for an automatic fine adjustment when matching the drive speed.

Setting pump calibration will be required anytime the automatic speed matching becomes out of range or when hydraulic components are replaced. The pump calibration is used as a manual coarse adjustment.

### NOTICE

On SLS Electric Power Pack SN F40710F-01, set the travel limit stops before calibrating the drive motor speed matching. Refer to Setting Travel Limit Stops in this section.

On the Diagnostic Display Module in the power pack:

1. Press CAL tab on default home screen.



2. The Select Calibration window appears. Press tab 3 Straight Track.



3. The Pump Calibration window appears.

4. If calibration adjustment is needed:

- Use right arrow tab button (A) to navigate to the value to be changed.
- Use the up (B) or down (C) arrow tab buttons to change the value.

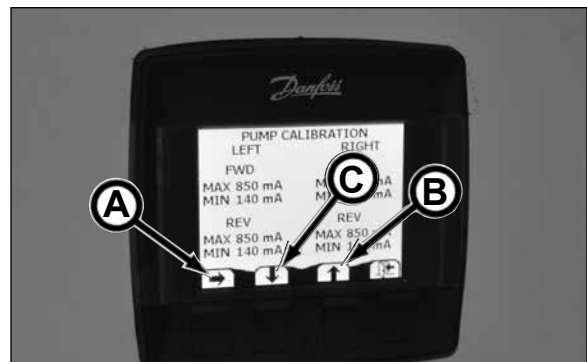

*(continued on next page)*

**NOTICE** BEFORE making changes on the pump calibration screen, be sure to change the correct left and/or right values. The left and right direction is referenced by the controller (A) always being in the rear location.

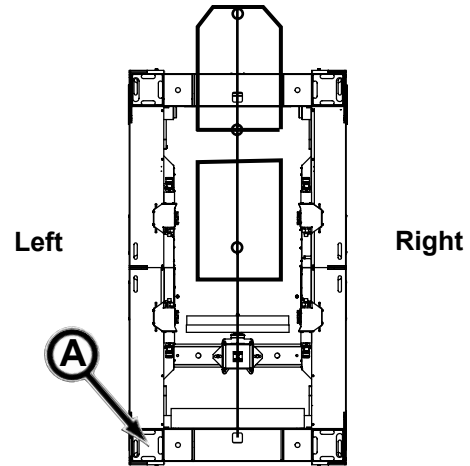

**5. Observe start drive operation.**

With the pendant drawbar control (A), SLOWLY move the drawbar (B) in the forward direction.

- If one side drive starts moving before the other, on the pump calibration screen, change MIN value on the slower side to a larger value. Once change is made, watch the operation to verify change is correct.

It is recommended to start the speed adjustment at 10 mA per trial and then use smaller increments to fine tune the speed matching.

Repeat procedure for reverse direction.

**6. Observe the drive movement operation.**

With the pendant drawbar control (A), move the control completely forward, at full speed moving the drawbar (B) the full operating range of the machine. DO NOT contact the drawbar to the drawbar stop.

- Compare the position of each side of the drawbar. If one side of the drawbar moves ahead of the other, on the pump calibration screen, change MAX value on the faster side to a smaller value. Once change is made, watch the operation to verify change is correct.

It is recommended to start the speed adjustment at 10 mA per trial and then use smaller increments to fine tune the speed matching.

Repeat procedure for reverse direction.

**7. Use the Exit tab (C) button to go back to Select Calibration window (D).**

**8. Use the Exit tab to go back to the default Diagnostic Display Module home screen (E).**

Contact your Akkerman Aftermarket Support representative with any questions.

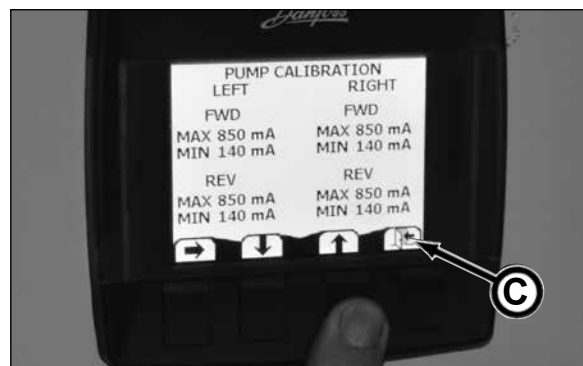
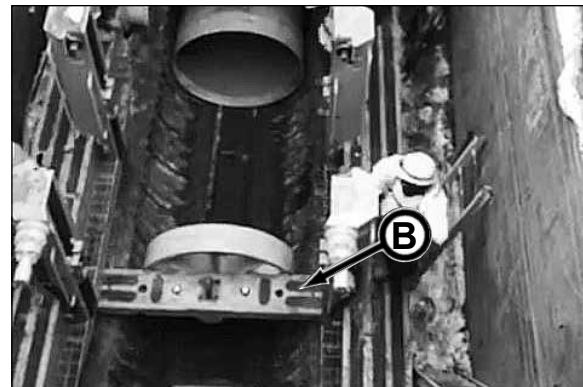

## ADJUSTING PVG FUNCTION SPEED CONTROL

The Sliplining System is equipped with a PVG valve which allows the operator to adjust the speed of the left and right elevators, clamp, winch and auxiliary functions.



On the Diagnostic Display Module in the power pack:

1. Press CAL tab on default home screen.



2. The Select Calibration window appears.

Press tab 2 PVG .



3. The PVG function window appears.

4. If function adjustment is needed:
  - Use right arrow tab button (A) to navigate to the value to be changed.
  - Use the up (B) or down (C) arrow tab buttons to change the value.

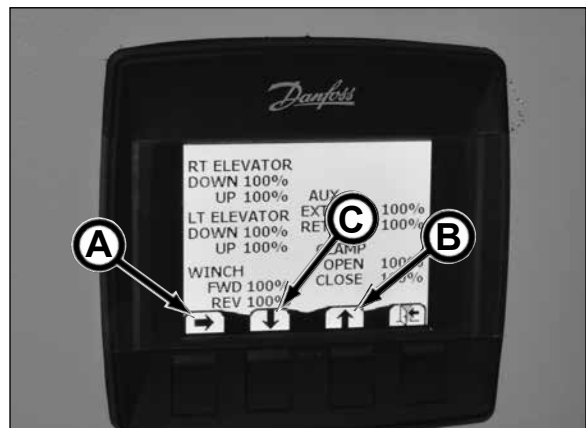

**NOTICE** BEFORE making changes on the PVG screen, be sure to change the correct left and/or right values. The left and right direction is referenced by the controller (A) always being in the rear location.

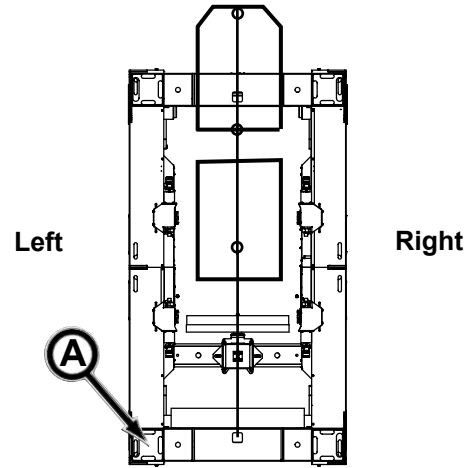

5. Observe the operation speed of the function to be modified.

- Elevator Control (A)
  - Elevator Selector Switch (B)
- Winch Control (C)
- Clamp Control (D)
- Auxiliary Control (E)



6. Change the percentage value to the desired function speed.

Slower is a lower %, 100% is full speed.

Changing the percentage of the function in the settings, changes the full output speed of the function joystick on the pendant control.

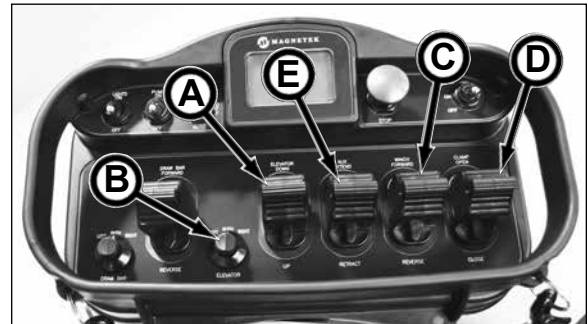

7. Once the function speed is modified, observe and verify that the operation of the function is correctly adjusted.

8. Repeat procedure for other functions as needed.

9. Use the Exit tab (F) button to go back to Select Calibration window (G).

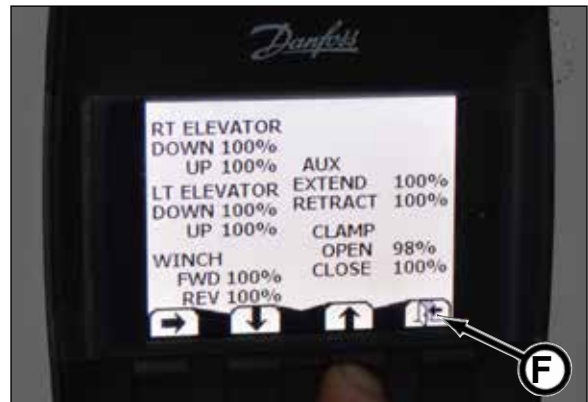

10. Use the Exit tab to go back to the default Diagnostic Display Module home screen (H).

Contact your Akkerman Aftermarket Support representative if you have any questions.

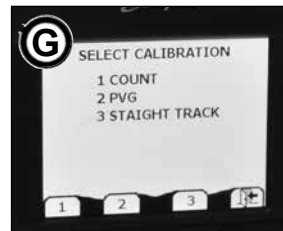

## SETTING DISPLAY TIME, DATE & BRIGHTNESS

To set the display time, date and brightness, go to the Diagnostic Display Module in the power pack:

1. Press Tools tab on default home screen.
2. The Time, Date and Brightness screen appears.
3. To change time or date settings:
  - a. Press Set tab as needed to navigate to the time or date setting that requires updating.
  - b. Use the up and down arrows to change the time or date setting.
  - c. Press the Set tab to navigate to the next setting to update.
  - d. Repeat as needed to change settings.
  - e. Press Set tab again to enter the setting.
4. To change the brightness setting:
  - a. Press Set tab as needed to navigate to the brightness setting.
  - b. Use the up and down arrows to the desired brightness setting.
  - c. Press Set tab to enter the setting.
5. To go back to the home screen, press the Exit tab (A).



## VIEWING INPUT/OUTPUT DATA

The electrical sensor inputs and outputs (raw data) are available on the Diagnostic Display. The values cannot be changed though they are useful for troubleshooting the machine operation.

To view the inputs/outputs go to the Diagnostic Display Module in the power pack:

1. Press I/O tab on default home screen.
2. There are two input screens and one output screen. Navigate through the screens using the left and right arrows.

If an input or output is active, a red square (B) will appear next to the input/output.

3. To go back to the home screen, press the Exit tab (C).
4. Contact your Akkerman Aftermarket Support representative with any questions.

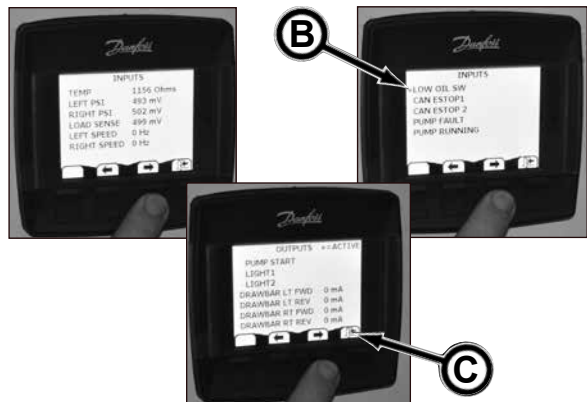

## VIEWING FAULTS

The machine inputs and outputs are constantly monitored. If there is an error in an input and/or output, a fault will display on the pendant LCD display and the power pack diagnostic display.



To determine the area of the fault, go to the Diagnostic Display Module in the power pack:

1. Press FAULT tab on default home screen.



2. There are two screens showing the available faults. Navigate through the fault screens using the left and right arrows.

If a fault occurs, a red square (A) will appear next to the fault.

3. To go back to the home screen, press the Exit tab.

4. A fault will require troubleshooting to clear the fault.

Contact your Akkerman Aftermarket Support representative with any questions.



## SYSTEM START-UP

**⚠ DANGER** Hazardous voltage. Disconnect and lock out/tag out power from source before servicing.



1. Push in all E-Stop buttons (A) to prevent accidental powering of equipment.
2. With **verification** for start up approval from all sliplining system equipment operators/workers, pull out E-Stop buttons and perform power pack start up procedure (refer to Power Pack Start Up Procedure in this section).

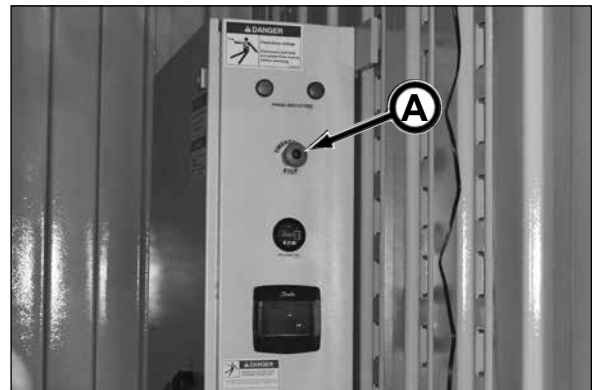

3. Run the drawbar under no load from one end of the travel to the other end for a minimum of five minutes. This will cycle the hydraulic system and purge any air from the hydraulic lines. This will also allow the operator to check the drive motor speed matching (for more information, refer to Adjusting Drive Motor Speed Matching in this section).
4. Operate the main drive, elevators, pipe clamp, winch and auxiliary (if used) functions. All functions must work properly before operating sliplining equipment.
5. The sliplining equipment is now available for use.



## CHECK HYDRAULICS AFTER SYSTEM START-UP

**⚠ WARNING** Escaping oil or other fluids under pressure can penetrate your skin causing serious injury or death.

Release all pressure before performing maintenance or repairs, Never weld near pressurized fluid lines.

DO NOT use your hands to check for leaks. When searching for leaks, use a piece of wood or cardboard.

Contact medical help immediately if any oil or fluid is injected into your skin. A serious infection or reaction can emerge without proper medical treatment.



1. Check all return filter indicators (A). Once operating temperature reaches at least 100°F (38°C), if the filter indicator needle is in the red CHANGE zone, replace filter(s).
2. Check hydraulic components and hoses for leaks. Repair or replace as needed.

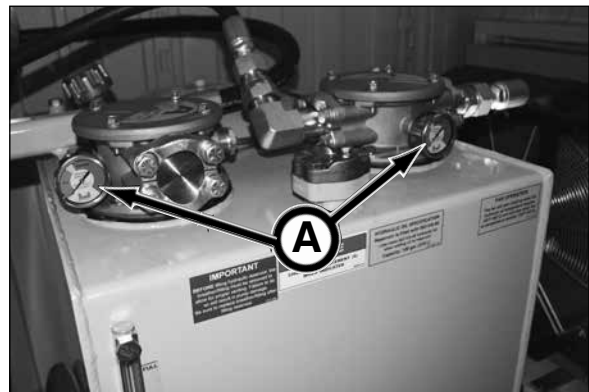

## LAUNCH SEQUENCE & ADDING NEW PIPE

Perform System Start-Up procedure before launching pipe in sliplining frame. Refer to System Start-Up in this section.

**⚠WARNING** Suspended loads may fall and cause severe injury or death. Do not allow anyone to enter area under or around a suspended load.

**NOTICE** Be sure the crane or excavator and all lifting equipment is rated to lift load. Remember, you may be able to lift the load in close at ground level, but as the load radius and elevation change, the lifting capacity of the crane or excavator or other lifting equipment may decrease.

**NOTICE** Never exceed maximum jacking thrust rating of the pipe. Consult pipe manufacturer to obtain this rating.

1. Adjust the pipe clamp band to fit the new pipe size being used for the project. Be sure the properly sized pipe shoe is installed to the pipe clamp.
2. (If using elevators) Install a cable or lifting strap (contractor supplied) between the elevator columns.

**IMPORTANT:** Do not use chain between the elevator columns. Chain will point load on pipe resulting in damage.

3. Prepare the initial pipe saver (shield) pipe (if used).
  - a. Install panels (A) to create the pipe shield frame. Be sure the panels with the mounts (B) are installed 180°. Mount with hex head cap screws (C), flat washers (D) and nuts (E).
  - b. Mount crossbar (F) to panel mounts with bolts (G), flat washers (H) and nuts (I).

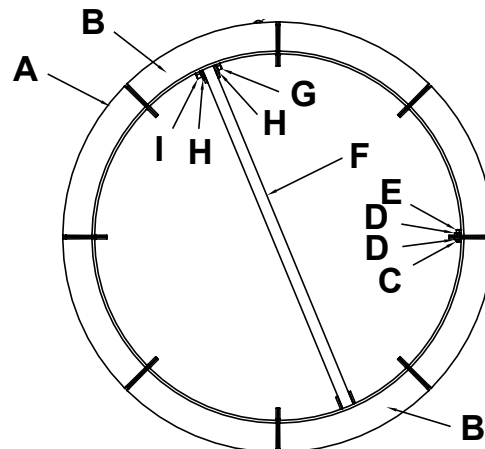
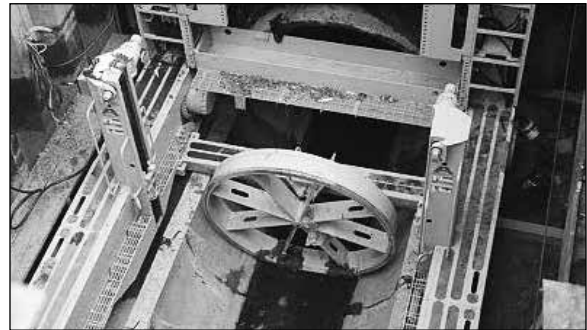

(continued on next page)

3. Prepare the initial pipe saver pipe (continued)

c. Bell up the pipe shield to the pipe and drill holes (using the holes in the shield) in pipe at the 12 o'clock, 3 o'clock, 6 o'clock and 9 o'clock positions. Use carriage bolts (A) and nuts (B) to secure shield to pipe.

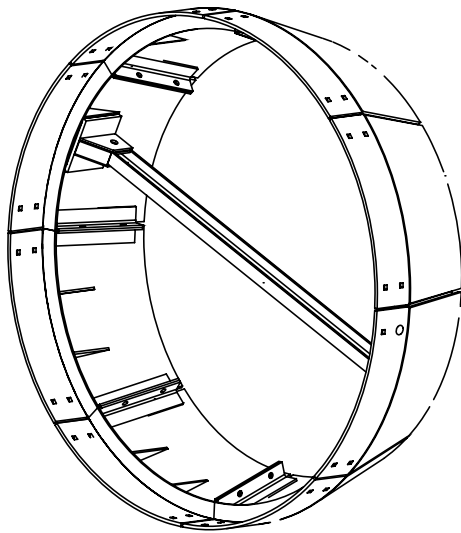

Pipe Saver (Shield) Assembly

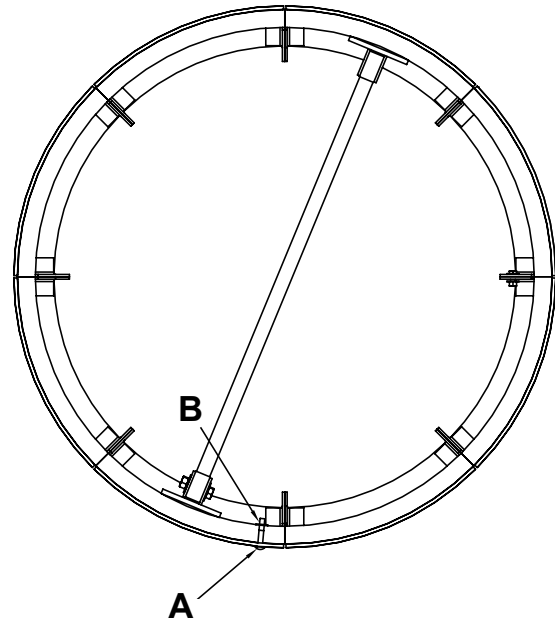

4. Move the drawbar (C) to the rear most position of the direction the pipe will be inserted. Be sure the drawbar contacts the travel limit stops. DO NOT allow the drawbar to contact the frame stops. Doing so may result in damage.

If the drawbar does not contact travel limit stops, reset the travel limit stops before continuing to operate,.

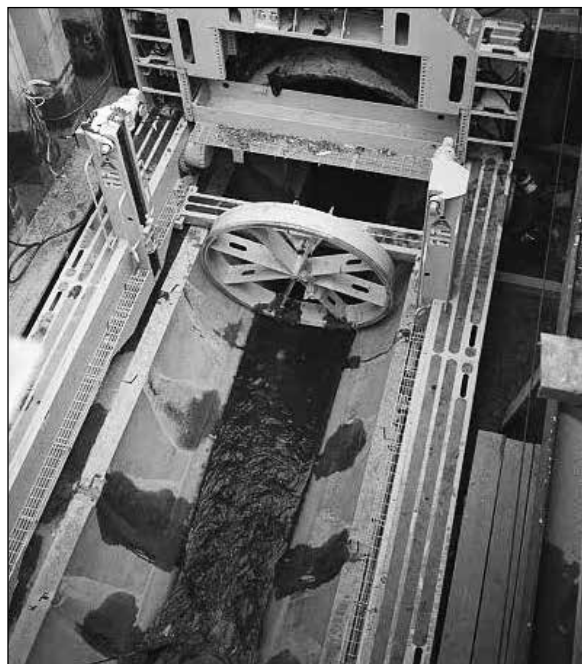

(continued on next page)

**⚠ WARNING** Suspended loads may fall and cause severe injury or death. Do not allow anyone to enter area under or around a suspended load.

**NOTICE** Be sure the crane or excavator and all lifting equipment is rated to lift load. Remember, you may be able to lift the load in close at ground level, but as the load radius and elevation change, the lifting capacity of the crane or excavator or other lifting equipment will decrease.



5. Secure lifting sling or other lifting device to the pipe.
- 6a. (If using elevators) Lift and move the pipe, with proper orientation, over the shaft area onto the elevator cables/sling.
- 6b. (If not using elevators) Lift and move the pipe, with proper orientation, into the shaft area.
7. Lower pipe into position.
8. Line up the thrust ring with the pipe.
9. Using the drawbar control move the thrust ring into the pipe. Be sure the thrust ring contacts evenly to the pipe.
10. With the drawbar positioning switch in the “Both” position, thrust the pipe forward into the pipe clamp.



11. Using the Pipe Clamp lever on remote pendant, close the pipe clamp (A) to tighten clamp around the pipe.



(continued on next page)

**NOTICE**

Attaching cabling through the pipe may be necessary to keep the pipe sections together when flowing fluid is present. This procedure includes attaching cable with the pipe and winch. Not all installations will require the cabling

12. Attach a pipe length cable (A) to the clevis (B) mounted in the middle of the pipe shield crossbar.
13. Route the winch cable (C) through lead block (D) and attach to cable installed in step 12.

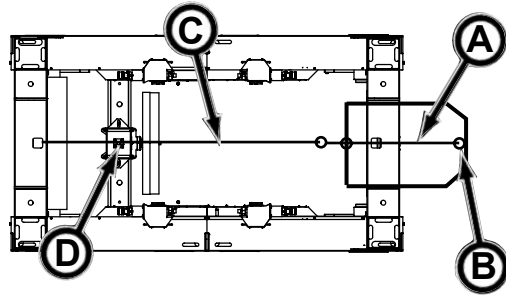

**IMPORTANT: Be sure cable does not contact pipe. Doing so may cause pipe damage.**

14. On pendant, retract Winch with lever (E) to remove slack in the cable.
15. On pendant, position Park Brake switch (F) to Auto position so the brake will automatically release when the drawbar lever is actuated.
16. Open the pipe clamp with lever (G).
17. Move the drawbar lever (H) in the direction that inserts the pipe. The lever is proportional so the farther the lever is moved, the faster the thrusting of the pipe. If using the winch, the winch cable tension must be released as the drawbar is thrusting forward.

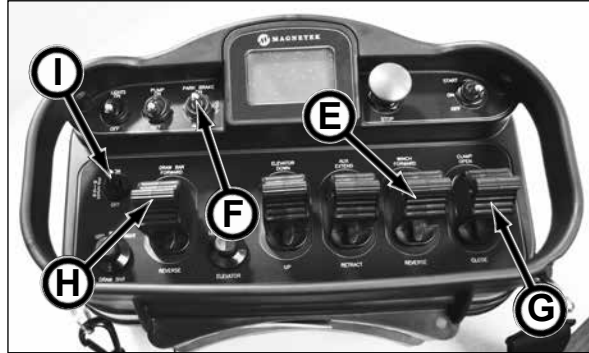

**NOTICE**

Use the high speed switch (I) as needed. The ON position is high speed, low torque; the OFF position is low speed, high torque.

18. Thrust pipe and leave a short portion of the pipe exposed in front of the pipe clamp so the next pipe can be lined up and “belled up” to the first pipe.



19. Close the pipe clamp (J).
20. Retract drawbar with drawbar lever to clear enough space for the next pipe.
21. Slacken the winch cable and remove winch cable from first pipe length cable.

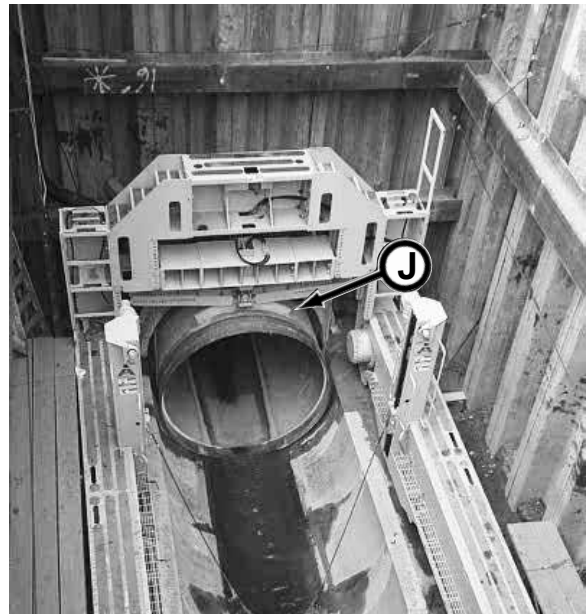

(continued on next page)

22. Attach a second pipe length cable (A) to the first cable (B).

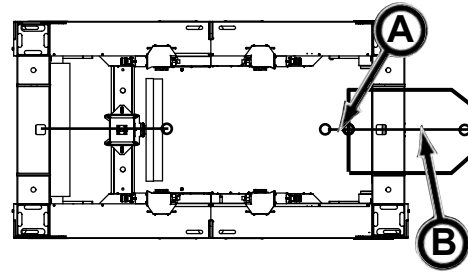

23. Lower the next pipe section into position in pipeline. Use elevators as needed.



24. Route the second cable (A) (installed in step 22) through the pipe and attach it to the winch cable (C).

25. Remove slack in cable by retracting winch cable.

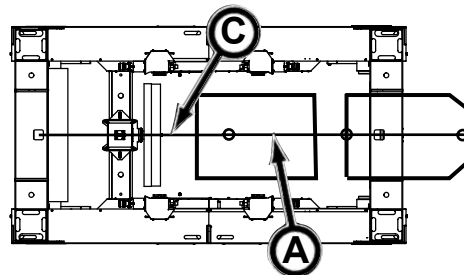

*(continued on next page)*

*Operation - Launch Sequence & Adding New Pipe*

26. Insert the thrust ring in the new pipe. Be sure the thrust ring contacts evenly to the pipe.
27. Use the drawbar lever and positioning switch as needed to carefully line up and push the new pipe in the first pipe.



28. Loosen the pipe clamp and release the cable tension.
29. Thrust pipe into pipeline.



30. Repeat steps 11 through 29 to install additional pipe in the pipeline.

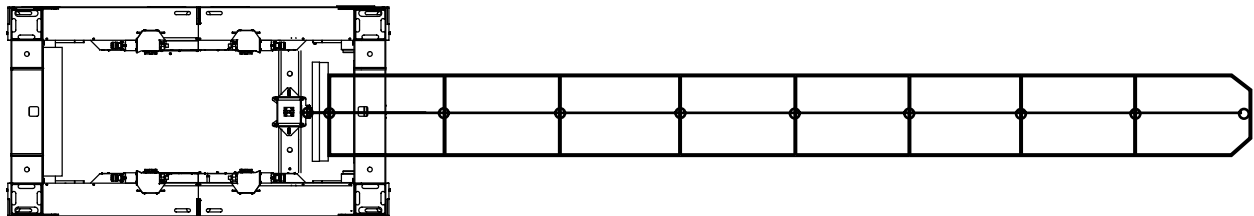

*Installing Pipe Into The Pipeline With Sliplining System*

## STOPPING THE POWER PACK 166 HP MOTOR

1. To stop the operation of the power pack 166 HP motor (A), on the wireless remote pendant, flip Pump switch (B) to the OFF position
2. If shutting down for the day, perform daily shutdown (refer to Daily Shutdown in this section).



## FILLING THE HYDRAULIC OIL RESERVOIR

Check hydraulic tank oil level gauge (A).

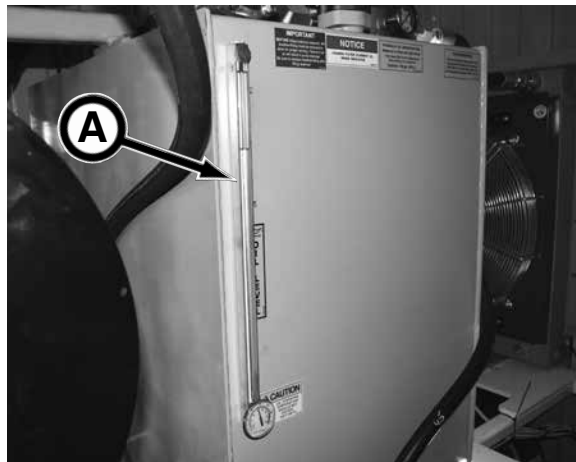

If the fluid level in the reservoir is less than 3/4 full, fill the reservoir with ISO-VG-68 Premium Hydraulic Turbine Oil as follows:

1. Remove hydraulic oil fill hose from storage location. Clean hose cap and hose end and remove cap from hose.



2. Place hose into clean hydraulic oil container.

**NOTICE** Refer to Fuels & Lubricants section for recommended hydraulic oil.

*(continued on next page)*



3. Open hydraulic fill shut off valve by moving handle up to the 3 o'clock position.



**IMPORTANT: BEFORE** filling hydraulic reservoir, the breather/fitting must be removed to allow for proper venting. Failure to do so will result in pump damage. Be sure to replace breather/fitting after filling reservoir.

4. Remove breather/fitting (A) from reservoir BEFORE filling reservoir to allow for proper venting during filling process.

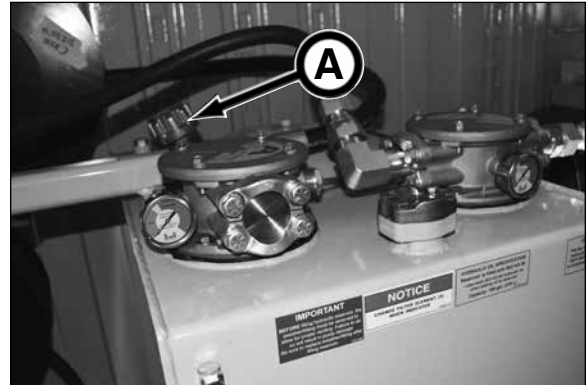

5. Flip Oil Transfer Pump switch in the power pack up to the ON position to pump hydraulic oil into the hydraulic reservoir.



(continued on next page)

7. Fill until oil reaches the high mark on gauge (A).

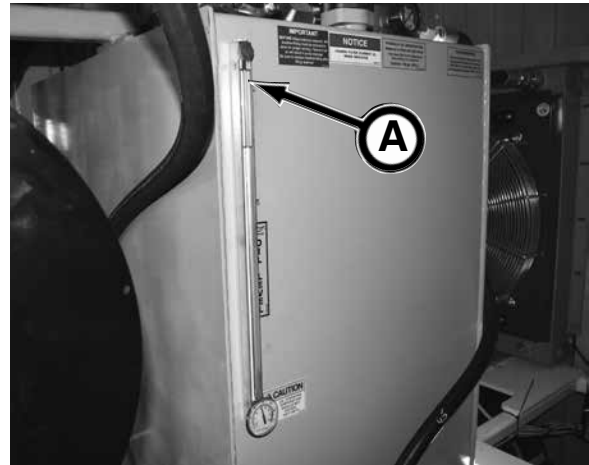

8. Flip Oil Transfer Pump switch down to the OFF position.



9. Replace breather/fitting (B) on reservoir.

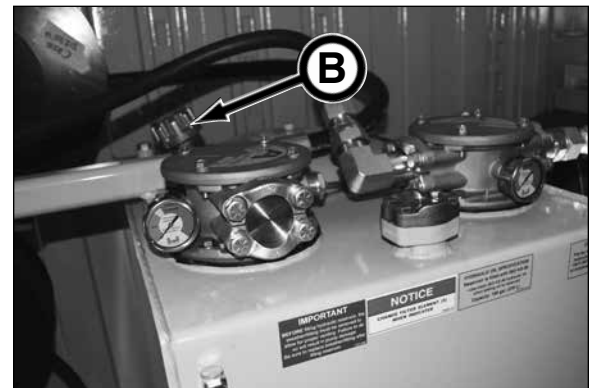

10. Close hydraulic fill shut off valve by moving handle down to the 6 o'clock position.

11. Replace cap on fill hose and place hose in storage location.



## DAILY SHUTDOWN

1. On the wireless remote pendant, flip Pump switch (A) to the OFF position to shut down the operation of the 166 HP electric motor (B).



2. Flip Start switch (C) to the OFF position to shutdown the pendant power.



3. Turn main power disconnect (D) to OFF position.
4. Push IN all E-Stop buttons (E).
5. Shut down generator or other power source and perform lockout/tagout procedure.

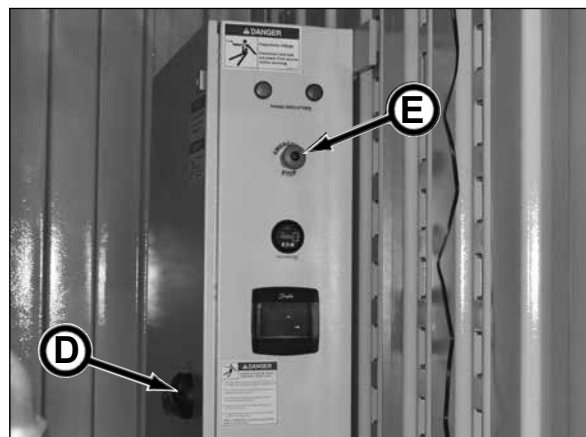

## REMOTE ACCESS DATA - POWER PACK

The Sliplining Power Pack System automatically logs data to be remotely accessed by the customer. The connection is achieved over a cellular data network. A customer supplied SIM card is required. The SIM card will be installed into the data modem installed in the Power Pack. The data is then collected, stored and provided to the remote user from the server module that is mounted in the power pack.

1. With power in lock out/tagout, open power pack control panel and install a SIM card into data modem slot (A). Once installed securely close control panel door.

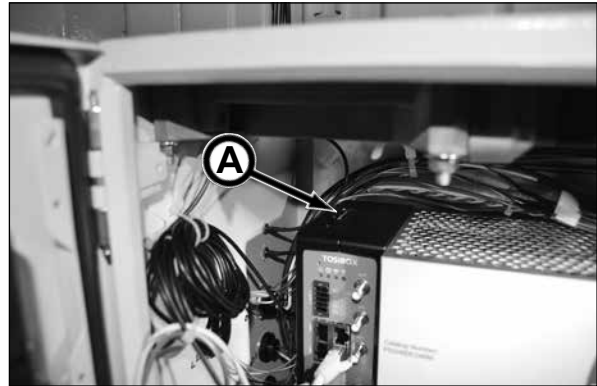

2. On the remote computer, install Tosibox® key from the address below:  
<https://www.tosibox.com/product/softkey/>
3. Double click the Tosibox Key program icon from the desktop to open the program.
4. Enter the supplied softkey code from Akkerman (contact your Akkerman Aftermarket Support representative for the softkey code).



5. On the List of Tosibox® Locks window and the SLS power pack is online, click connect. Once connected right click on “Akkerman SLS” and click “Open with browser (HTTP)”.



6. The web browser will automatically open the remote access web dashboard.
7. From the web dashboard or the menu column on the left side of the window, click on the desired data:
  - **Home:** web dashboard window
  - **Live Data:** view near real time key engine (if equipped) power pack hydraulics and frame tonnage data
  - **Live Data Graph:** select parameters to graph over a period of time
  - **Log Files:** management of tonnage data logs
  - **Error Log:** internal server module data event log (used for troubleshooting)
  - **Documentation:** view or download PDF manuals and schematics

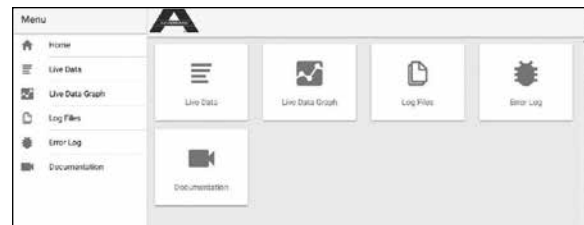

(continued on next page)

### 8. LIVE DATA

Click on Live Data to view the near real time engine, power pack hydraulics and tonnage data.

Name	Value	Unit
Engine Boost Pressure	2.32	PSI
Engine Coolant Temperature	60.00	C
Engine Intake Manifold Temperature	34.00	C
Engine Oil Pressure	67.28	PSI
Engine Percent Load	17.00	%
Engine RPM	1790.73	RPM
Hydraulic Oil Temperature	98.00	F
Hydro 1 Pressure	402.00	PSI
Hydro 2 Pressure	388.00	PSI
Load Sense Oil Pressure	4.00	PSI
Location	www.google.com/maps/place/43.74314, 92.88623	
Tonnage	0.00	Ton

### 9. LIVE DATA - Power Pack Map Location

To show the actual location of the power pack, highlight location information, right click and then select Go To link (A). A new window will open with a photo and location coordinates of the power pack (B), providing a GPS signal is available.

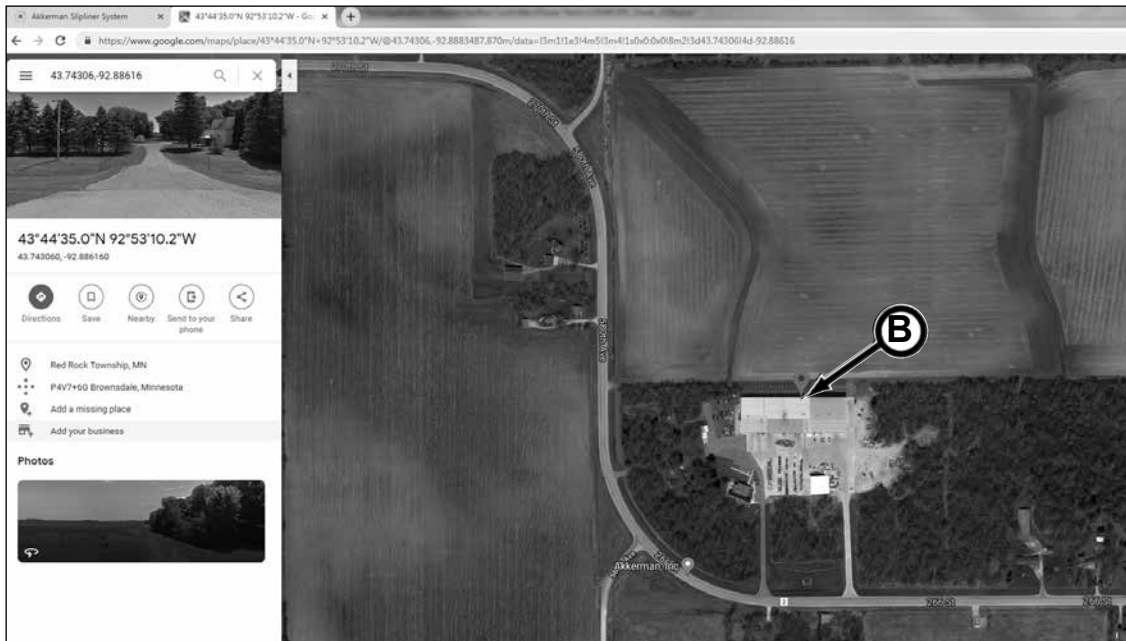

(continued on next page)

## 10. LIVE DATA GRAPH - Trend Data

Select Live Data Graph to visually graph live data trends for a period of time.

- To add Graph, click + (A). The Add Graph window will appear.
- Use the pull down menu (B) to select the desired data parameter.
- Scale the graph by typing in the minimum and maximum (C) variables of the data.
- In the Window field (D), type in the length of time in seconds to graph the data trend. The graph will accumulate up to the maximum seconds and then remove the oldest data while continuing to graph the data trend.
- Once graph values are entered, click Add Graph (E) button.

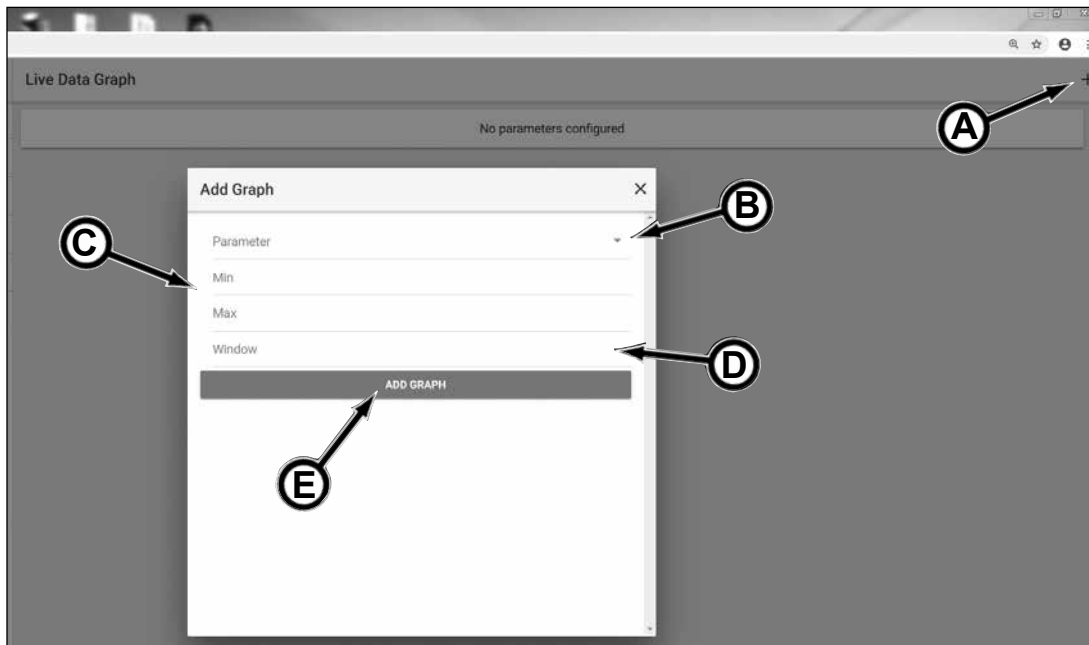

- To edit the values in the graph, click the pencil icon (F). The Edit Graph window will appear. Change the values as needed. Click Update Graph button (G) to display the new graph.

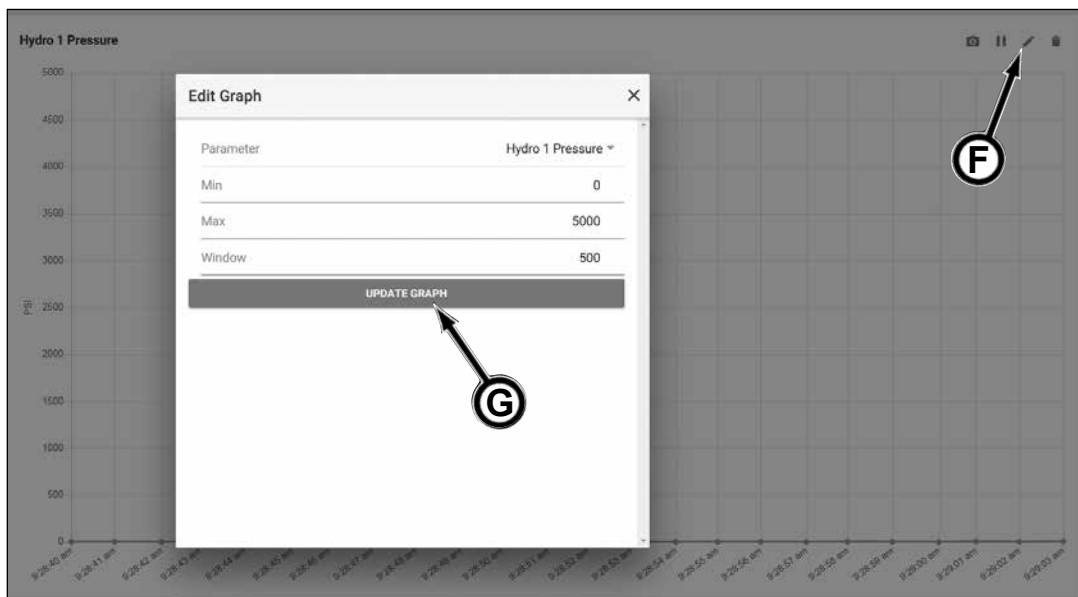

(continued on next page)

## 11. LOG FILES

A listing of the log files is shown on the Log Files window which allows for the retrieval and management of the data log files.

Data logging files (A) are automatically generated (from power pack internal flash drive) with the drawbar tonnage, hydraulic oil temperature, engine coolant temperature and engine oil pressure (if equipped) every second with the date and time.

Once job is complete, clear data log files to eliminate confusion of files before starting new job. If required, download all .log files to a project folder on computer before deleting log files.

To view the data information:

- Click on the desired log file download button (B). Save the file on the computer desktop or other desired directory location.

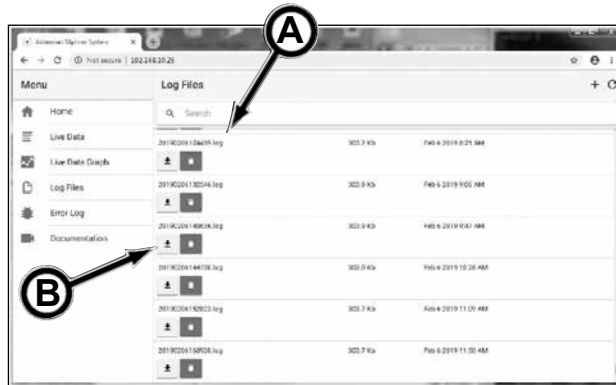

- Change the file name from .log to .csv (Comma Separated Value). The .csv file is a spread sheet program format and will open in Microsoft® Excel or other spread sheet program.
- Open .csv file (C) to view data. Reformat columns as needed.

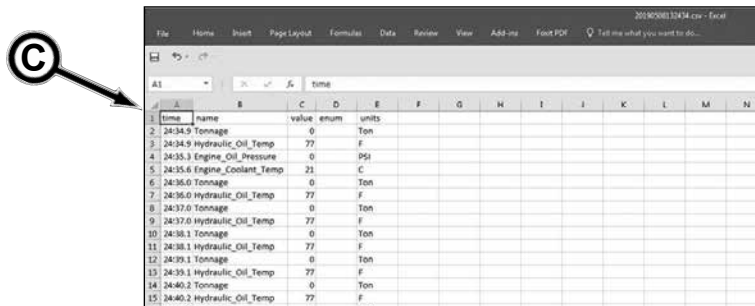

To delete log files:

- After job completion, delete .log files. On the log file(s) to delete, click the appropriate trash can icon (D). A Confirm window appears. Click Delete (E).

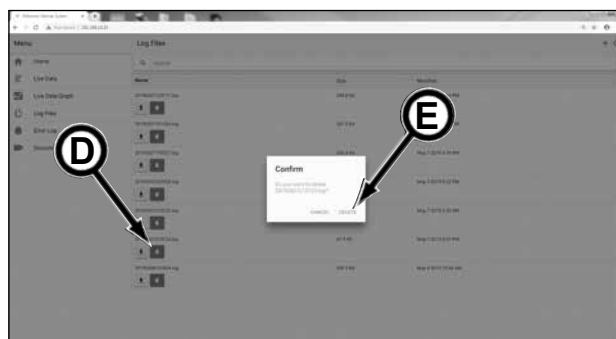

(continued on next page)

## 12. ERROR LOG

The error log page creates a log file of the internal server module operating system. This may be used during troubleshooting.

## 13. DOCUMENTATION

The Documentation page displays a listing of manuals and schematics (A). Click on the view (B) or download (C) icons.



## COLD WEATHER OPERATION

Freezing temperatures during the sliplining process, creates the necessity to prepare the site and equipment for the cold weather. Failure to do so will cause damage to components and supporting equipment.

- For all equipment, use proper lubricant based on ambient temperature to prevent damage.
- If equipped with an engine, refer to the engine operator's manual for important details for operating the engine in cold weather to prevent damage.
- Install heaters for hydraulic systems.
- If systems were shut down for freezing weather, be sure to start systems slowly and let them run for at least five minutes to allow for warm up and in the case of a pump, to displace any surface ice that may have accumulated in the fluid before going back to full operation mode.
- Remember it is also critical to keep the work site safe and employees comfortable during the freezing weather. Good training, supervision, proper clothing and limiting personal exposure to the weather is essential for keeping personnel and equipment safe on the job site.

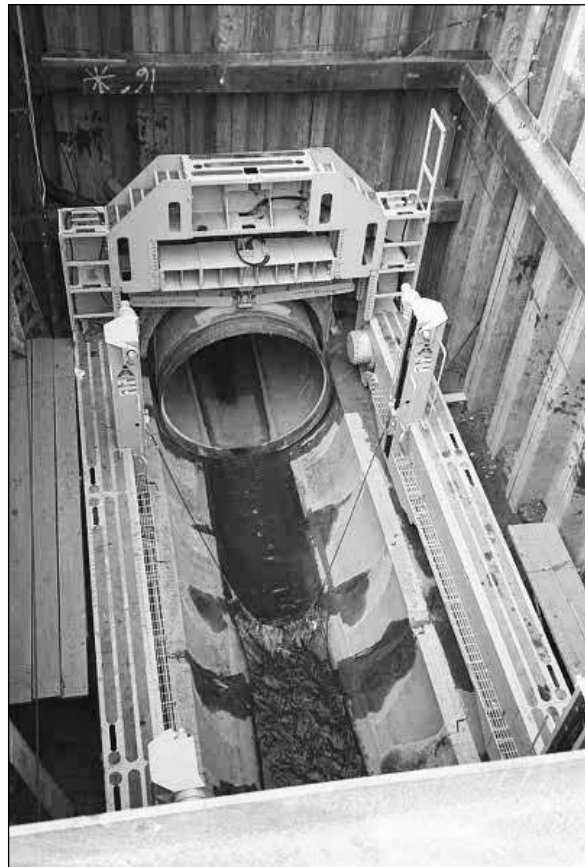

## RECONFIGURING THE SLIPLINING FRAME

The Sliplining frame is modular and can be changed in length and width to accommodate different pipe sizes. Different frame width and length components are used to accommodate pipe sizes. Also, different size thrust rings and pipe clamp components must be used to fit specific pipe sizes.

Below are the areas that require updating when reconfiguring the Sliplining frame:

- I. Changing Frame Width
- II. Changing Frame Length
- III. Changing The Thrust Ring
- IV. Changing/Removing Drawbar
- V. Changing The Pipe Clamp Assembly

**⚠ WARNING** TIPPING HAZARD.  
BEFORE reconfiguring frame, install ALL four angle supports to frame sections. Failure to do so can cause serious injury or death.

**⚠ WARNING** Suspended loads may fall and cause severe injury or death. Do not allow anyone to enter area under or around a suspended load.

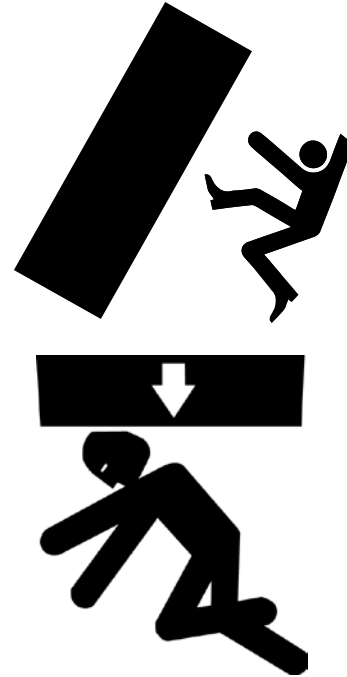

### I. Changing Frame Width

**NOTICE** Refer to the illustration on next page while reconfiguring the frame.

1. Install an angle support (A) on each corner of the sliplining frame. Be sure each support is properly installed and the leveling screw is properly adjusted.
2. Remove the winch housing/center section.
3. Remove the other center section on the opposite end.
4. Remove the pipe clamp assembly and the upper clamp spacers.
5. Remove the draw bar assembly and thrust ring (refer to IV. Changing/Removing Drawbar).
6. Adjust the width of the equipment remaining to accept the new and modified components.
7. Change the drawbar assembly (refer to IV. Changing/Removing Drawbar).
8. Gather the spacers for the pipe clamp assembly and the center sections required for the reconfiguring of the frame.

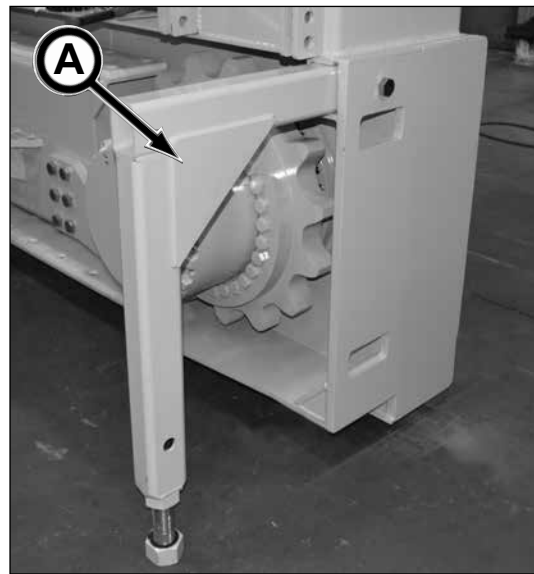

*(continued on next page)*

9. Install the new drawbar assembly.
10. Install the new upper and lower spacers for the pipe clamp assembly.
11. Install the winch housing/center section.
12. Install the other center section assembly.
13. Reinstall the pipe clamp assembly.
14. Change the pipe clamp assembly (refer to V. Changing The Pipe Clamp Assembly).
15. Install the new thrust ring.

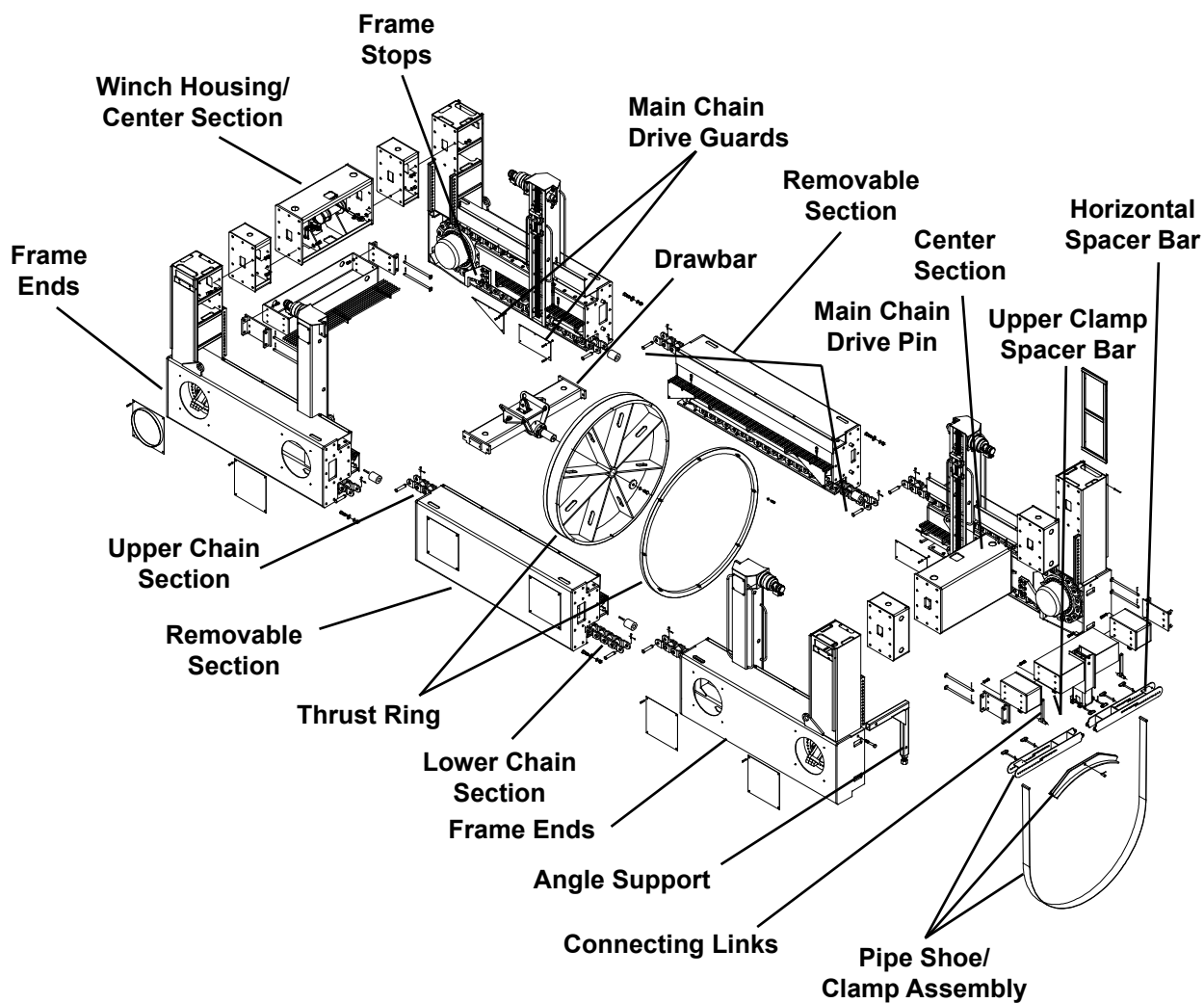

## II. Changing Frame Length

### NOTICE

Refer to the illustration on next page while reconfiguring the frame.

1. Actuate drawbar to a center seam frame section.
2. Remove guards over the main chain drive.
3. Loosen chain tensioner enough to separate frame 5 to 6 in. (127 to 152 mm) for access to pins.
4. Locate and remove pins in the chain, corresponding to the removable section.

### WARNING

Chain sections are heavy! Be sure to use properly rated lifting device. Severe injury or death can occur from falling loads.

5. Remove upper and lower chain sections, corresponding to the removable section.
6. Release hydraulic pressure. Disconnect all hydraulic lines adjacent to the removable sections and install caps and plugs where needed.
7. Provide appropriate support for the removable sections before removing fasteners. Once properly supported, remove the fasteners and remove the section.

### WARNING

Removable sections are unstable after fasteners are removed. Use appropriate support to stabilize removable sections before removing. Severe injury or death can occur from tipping loads.

8. Reposition the frame ends adjacent to each other, reconnecting fasteners and hydraulic hoses. Torque fasteners per chart in section 12, Specifications.
9. Install pins and fasteners in the main chain drive.

### NOTICE

Reverse the complete process when making the frame longer.

## III. Changing The Thrust Ring

1. Fully support load of thrust ring. Secure lifting device to the thrust ring.

### WARNING

Be sure to use properly rated lifting device. Severe injury or death can occur from falling loads.

2. Remove fastener from the thrust ring center shaft.
3. Slide thrust ring off the center shaft with the lifting device.

Reverse the complete process when installing the other thrust ring. Torque fasteners per chart in section 12, Specifications.

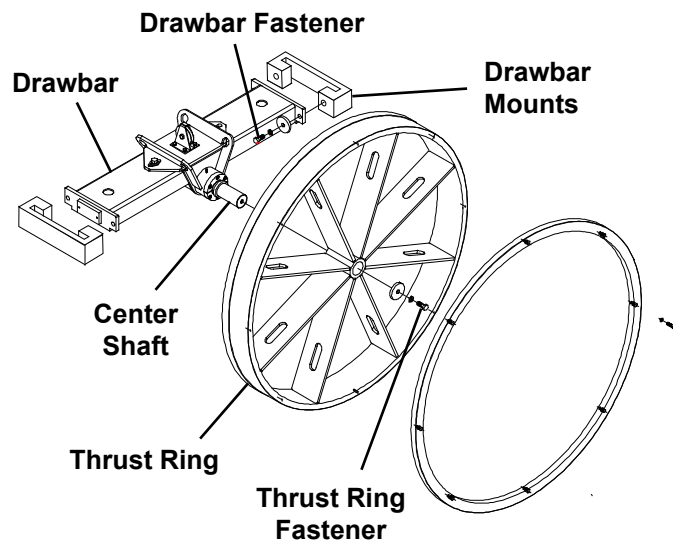

#### IV. Changing/Removing Drawbar

1. Remove bolts in frame stops at one end of the frame.
2. Activate drawbar to the end of the frame enough for drawbar to be lifted out vertically.
3. Remove fasteners from drawbar mounts.
4. Lift drawbar vertically out of mounts.

Reverse the complete process when installing a different drawbar. Torque 1 in. stop fasteners per chart in section 12, Specifications.

#### V. Changing The Pipe Clamp Assembly

**IMPORTANT: If pipe clamp assembly is installed incorrectly, pipe distortion may result.**

After installing the appropriate pipe size specific components, such as spacers, drawbar, thrust ring, pipe shoe:

1. Retract pipe clamp cylinder.
2. Adjust the width of the connecting links (A) to the appropriate horizontal spacer bar (B) upper holes. The pipe size diameters are stamped next to the holes on the horizontal spacer bar.
3. Adjust the connecting links to the adjustable upper clamp spacer bar (C) so the links are in the vertical position.
4. Install appropriate sized pipe clamp band (D) to the appropriate stamped pipe size diameter lower holes in the horizontal spacer bars (B).

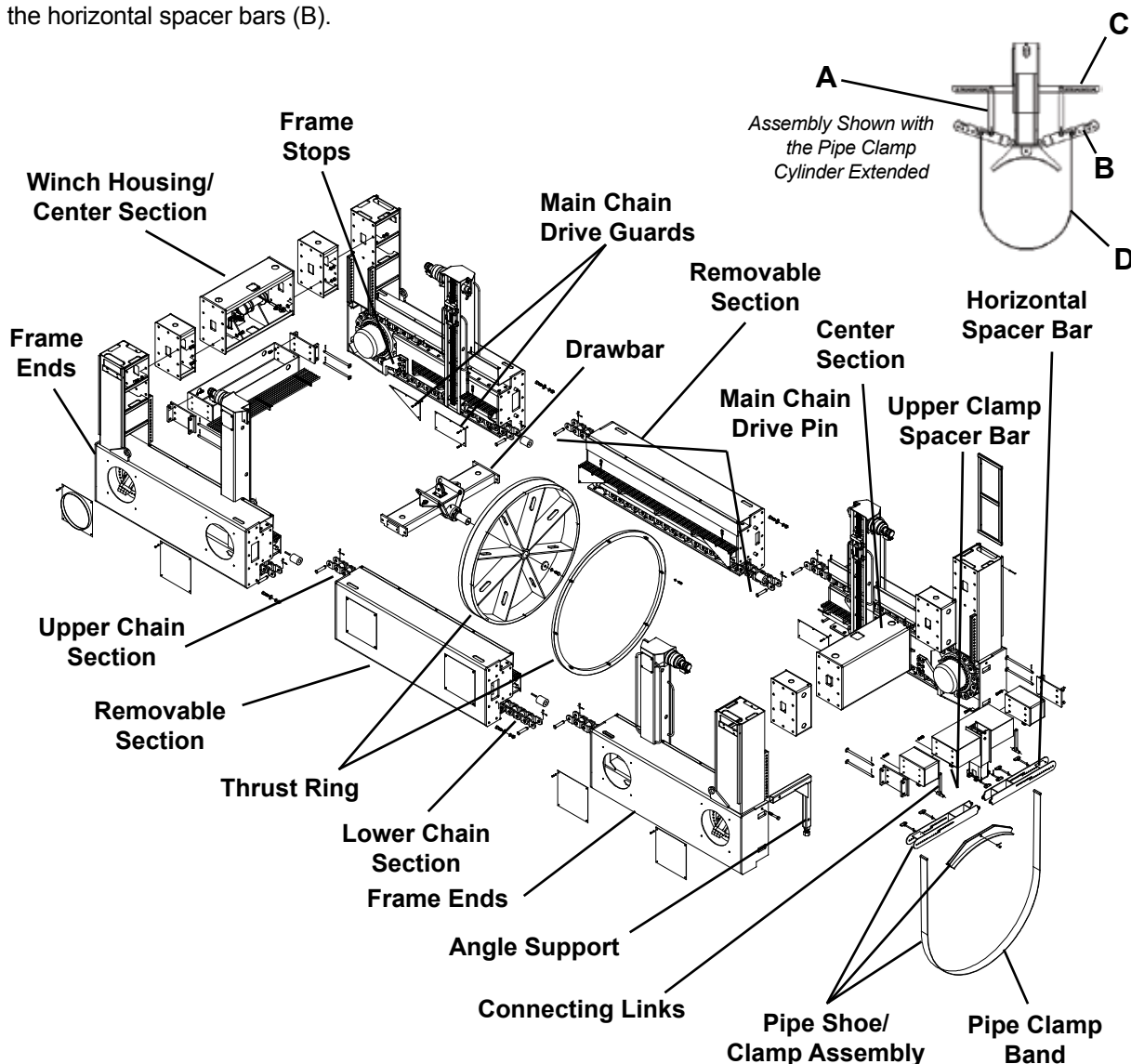

## REMOVING SLIPLINING SYSTEM

**⚠ WARNING** Any electrical work completed on the sliplining system **MUST** be performed by a certified electrician.

When pipe line is complete, remove the sliplining system as follows:

**NOTICE** Before removing the sliplining system, be sure to review the Completion of Each Drive maintenance in section 9, Maintenance.

1. Perform daily shutdown procedure (refer to Daily Shutdown in this section).
2. LOCKOUT/TAGOUT power source(s). Push in ALL E-Stops.
3. Disconnect power pack power cable from generator and coil in the power pack for storage.
4. Remove Comm To Frame and Power To Frame cables from Sliplining frame electric harness bulkhead and coil up and store in power pack.
5. Relieve hydraulic pressure.
6. Disconnect hydraulic hose sliplining frame and power pack quick disconnects. Carefully rewind hoses on reels. Secure reels from rolling with clamps.
7. Connect frame case drain hose quick disconnect to the case drain thermal relief tank quick disconnect.

**IMPORTANT:** Be sure to keep gas detectors and oxygen deficiency detectors in the shafts while personnel are working on removing the sliplining equipment and finishing the pipeline.

8. Remove the pipe clamp band (A). Store pipe clamp band properly.

**⚠ WARNING** Suspended load may fall and cause severe injury or death. Do not enter area under or around a load.

**NOTICE** Be sure to observe lifting instructions for the sliplining frame, power pack and any other supporting components. Refer to Lifting Instructions in the Transporting section for the sliplining equipment.

9. Remove sliplining frame, power pack and other components from shaft.
10. Finish pipeline per job requirements such as; grout the annular space between the exterior pipe surface and the new tunnel pipe, install/repair manholes (if required) and remove shoring etc. from the shafts and backfill them as needed.

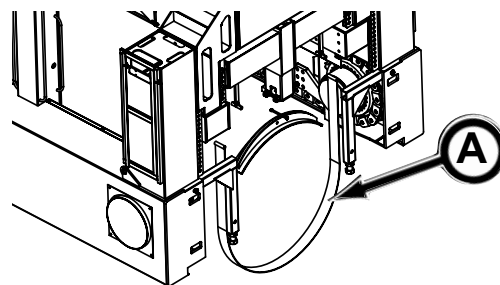

# Transporting

## TRANSPORTING GUIDELINES

**⚠ WARNING** Suspended load may fall and cause severe personal injury or death.

Do not enter area under or around a load.



1. Know the local, state, and federal transportation regulations.
2. Obtain required permits for transporting.
3. Remove any obstacles from the trailer floor.
4. Clean debris from equipment.
5. Load and unload on level ground.
6. If lifting equipment with a hoist or other lifting device, the equipment lifting eyes and sling must be inspected for damage before lifting. If damaged, replace before lifting.
7. Securely fasten equipment to trailer floor.
8. Secure all loose items.
9. Observe the lifting instructions on the sliplining frame and the power pack (refer to the lifting instructions on the next page).

## LIFTING INSTRUCTIONS

### 1. Sliplining Frame

- Sliplining frame weight is 35,000 lbs. (15,875 kg).
- Lifting with a crane requires a four part sling with legs a minimum of 25 ft. (7.62 m) long.
- Slipliner must lift freely. If it is stuck to the ground, it must be broken loose prior to lifting.
- Slipliner lifting eyes and sling must be inspected prior to each lift. Any damage must be repaired prior to lifting.

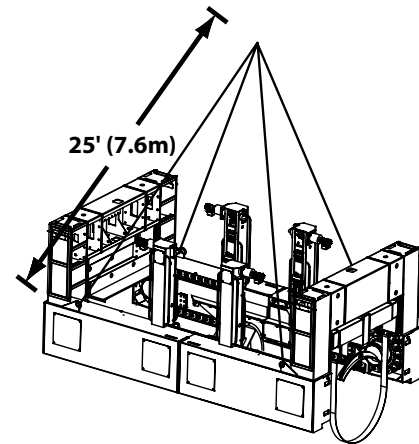

### 2. SLS Power Pack

- Power Pack weight is 11,000 lbs. (4,990 kg).
- Lifting with a crane requires a four part sling with legs a minimum of 10 ft. (3 m) long.
- Container must lift freely. If it is stuck to the ground, it must be broken loose prior to lifting.
- Lifting eyes and sling must be inspected prior to each lift. Any damage must be repaired prior to lifting.
- All container doors must be closed before lifting.

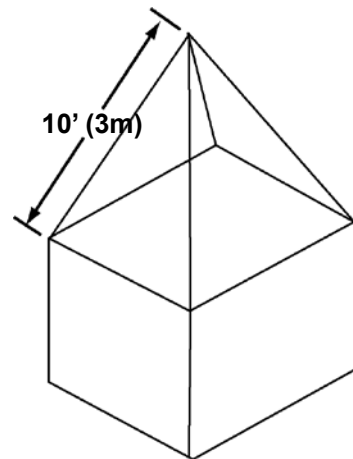

# Lubricants

## NOTICE

Use of inferior lubricants can affect the efficient performance of your sliplining system. Always use high quality lubricants as specified in this section. Refer to the Periodic Maintenance section for proper lubrication quantity, maintenance intervals, and procedures.

## POWER PACK HYDRAULIC OIL RESERVOIR LUBRICANT

The power pack oil reservoir is typically filled with ISO-VG-68 Premium Hydraulic/Turbine Oil.

Use an API GL-1/GL-2 or equivalent when adding or changing lubricant.

## NOTICE

If using a too heavy of viscosity oil in cold temperatures, hydraulic oil pump damage could result due to pump cavitation. On the contrary, using ISO 32 oil above 150°F operating temperatures (oil temp. in reservoir) will result in reduced hydraulic power to functions.

Recommended hydraulic oil:

Ambient Temp.	Hydraulic Oil
-25°F to 60°F (-32°C to 16°C)	ISO 32
0°F to 95°F (-18°C to 35°C)	ISO 46
32°F to 105°F (-0°C to 41°C)	ISO 68

## NOTICE

If you change to a different oil, use a reputable oil supplier to meet or exceed the ISO-VG-68 or API GL-1/GL-2 oil specification. **Do not mix oil manufacturers or grades.**

Oil capacity is approximately 100 US gal. (379 L).



## ELECTRIC MOTOR GREASE

The electric motor bearings with are lubricated with Mobil Polyrex® EM grease or equivalent (refer to Grease Type below). The Polyrex® EM grease is a specially formulated grease for electric motor bearings.

**GREASE TYPE (unless nameplate states otherwise:**

**Nameplate Ambient Temperature between -22°F (-30°C) to 150°F (65°C) inclusive:**

Recommended grease for standard service conditions is Mobil Polyrex® EM. Equivalent and compatible greases include: Texaco Polystar RB, Rykon Premium #2, Pennzoil Pen 2 Lube, Chevron SRI & Mobil SHC 100.

**Nameplate Ambient Temperature below -22°F(-30°C):**

Special low temperature grease is recommended such as Aeroshell 7 or Beacon 325 for ball bearings and Mobil SHC 100 for roller bearings.

Use Mobil Polyrex® EM grease or equivalent when lubricating the motor bearings. Refer to section 9, Periodic Maintenance for more information.



## MAIN DRIVE PLANETARY GEAR BOX LUBRICANT

The main drive planetary gear boxes (A) are filled with Mobil SHC™ 630 Synthetic Bearing and Gear oil. This oil is formulated to provide extra protection for gears, bearings and seals.

Use Mobil SHC™ 630 gear oil or ISO-VG-220 oil equivalent when adding or changing lubricant.

**NOTICE** If you change to a different oil, use a reputable oil supplier to meet or exceed the Mobil SHC™ 630 oil specification. **Do not mix oil manufacturers or grades.**

Main drive planetary gear box oil capacity is approximately 3 gal. (11 L).

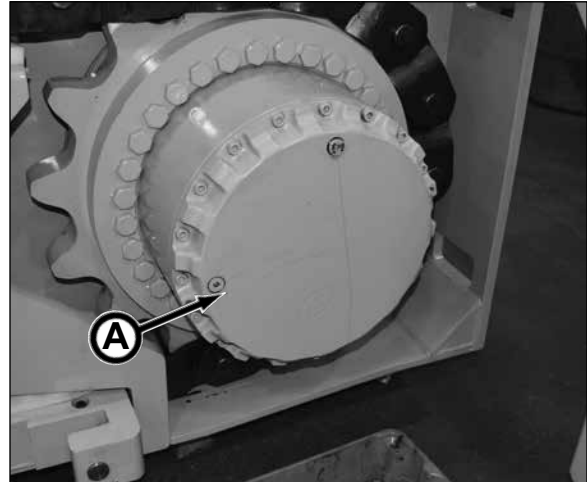

## ELEVATOR PLANETARY GEAR BOX LUBRICANT

The elevator gear boxes (B) are filled with Mobil SHC™ 630 Synthetic Bearing and Gear oil. This oil is formulated to provide extra protection for gears, bearings and seals.

Use Mobil SHC™ 630 gear oil or ISO-VG-220 oil equivalent when adding or changing lubricant.

**NOTICE** If you change to a different oil, use a reputable oil supplier to meet or exceed the Mobil SHC™ 630 oil specification. **Do not mix oil manufacturers or grades.**

Elevator gear box oil capacity is approximately 23 oz. (89 ml).

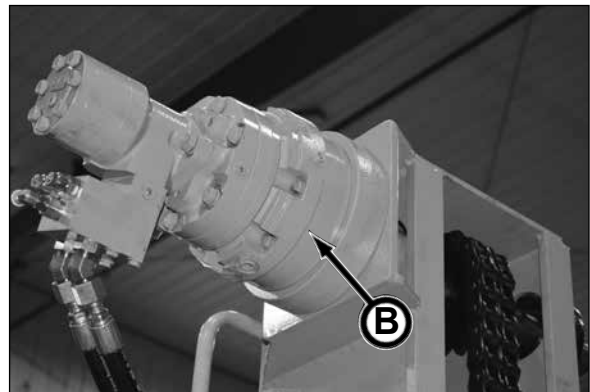

## GREASE

The lubrication points are greased (C) with Mobilgrease® XHP222 Premium Lubricating Grease.

The XHP222 grease is a multi-purpose, high performance, high temperature, lithium grease.

Use Mobilgrease® XHP222 Premium Lubricating Grease or equivalent when lubricating the lubrication points.

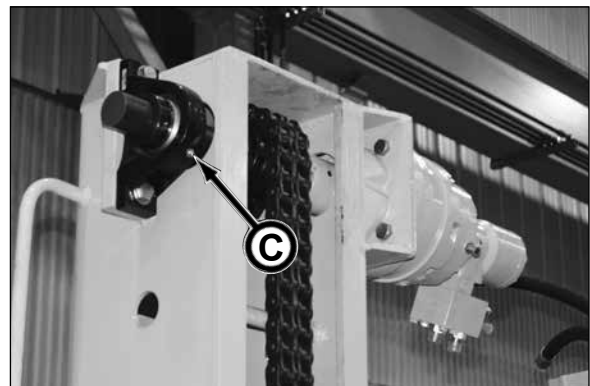

## DRIVE CHAIN & ELEVATOR CHAIN LUBRICANT

The drive chain (A) and elevator chain (B) are lubricated with SAE 90 (Schedule 220) gear oil or equivalent.

In storage, spray LPS® 3 Premier Rust Inhibitor on chain.

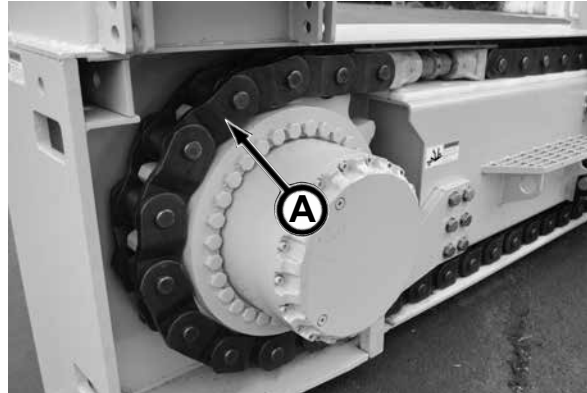

*Drive Chain (A)*

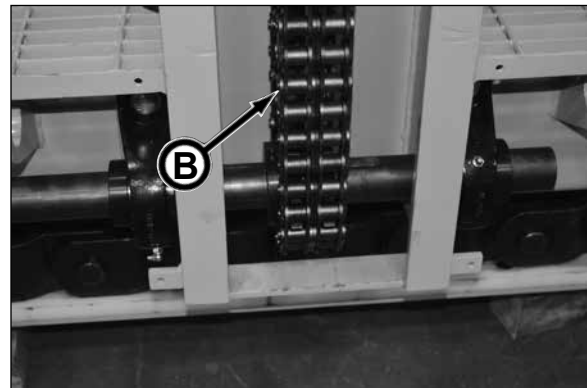

*Elevator Chain (B)*

## WINCH GEAR CASE LUBRICANT

The winch gear case (C) is filled with Bloom® Ulltra-Lube no. 601 trans-worm gear oil.

Use Bloom® Ulltra-Lube no. 601 trans-worm gear oil or 80W90 superior multi-purpose gear oil when adding or changing lubricant.

**NOTICE** If you change to a different oil, use a reputable oil supplier to meet or exceed the 80W90 superior multi-purpose gear oil specification. **Do not mix oil manufacturers or grades.**

Winch gear case oil capacity is approximately 2 pt. (946 ml).

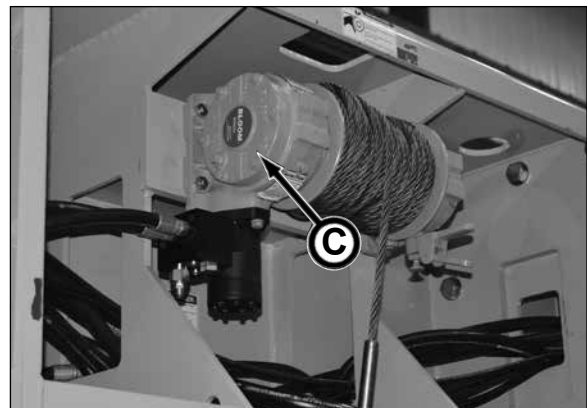

---

## STORING LUBRICANTS

Your equipment can operate at maximum performance only if clean lubricants are used. Use clean containers to handle all lubricants.

Lubricants should be stored in an area protected from dust, moisture, and other contaminants.

Store barrels inside whenever possible or at least under cover. Keep barrel bungs tight.

If barrels must be stored outside, lay barrels on their sides. If barrels cannot be laid on their sides, tilt them slightly so water or other contaminants cannot be drawn in around the bung.



# Periodic Maintenance

**⚠ WARNING** Review the Safety section in this manual before performing maintenance. Failure to do so, could cause severe injury or death.

Maintenance and repairs must only be performed by a qualified service technician.

---

## LUBRICATION & MAINTENANCE INTERVALS

The requirements for lubrication and maintenance are shown on the maintenance charts in this section.

Intervals of maintenance are based on normal operating conditions. If operating under more difficult conditions, use a shorter time interval between maintenance.

Use the hourmeters (A) on each module to help determine proper maintenance intervals.

The hourmeters register in full hours and 1/10ths hours.

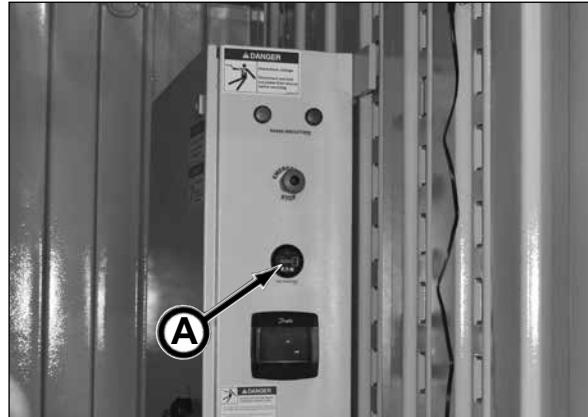

---

## LOCKOUT TAGOUT POWER BEFORE SERVICING

**⚠ WARNING** Severe personal injury or death can result from unexpected pump unit start-up or machine movement.

LOCKOUT, TAGOUT power before attempting to make repairs or adjustments to this equipment, unless otherwise indicated. Proper lockout tagout will prevent accidents and save lives. Performing the lockout tagout will also prevent the equipment from moving or operating unexpectedly.

1. Flip main power disconnect switch (B) in power pack to the OFF position.
2. Push all E-STOP buttons (C) IN including any remote E-STOP buttons.
3. Shutdown power from the power source.
4. Lockout/tagout all power sources.



---

## BEFORE PERFORMING MAINTENANCE

1. Perform daily shutdown procedure. Refer to Daily Shut Down in the Operation section.
2. Relieve hydraulic pressure.
3. Push in all E-Stop button(s).
4. Do not work on hydraulic system if oil temperature exceeds 150° F (66° C).
5. **Lockout tagout all power. Perform lock out/tag out procedure.**

---

## HYDRAULIC OIL/FLUIDS UNDER PRESSURE

**⚠ WARNING** Escaping oil or other fluids under pressure can penetrate your skin causing serious injury or death.

Release all pressure before performing maintenance or repairs. Never weld near pressurized fluid lines.

DO NOT use your hands to check for leaks. When searching for leaks, use a piece of wood or cardboard.

Contact medical help immediately if any oil or fluid is injected into your skin. A serious infection or reaction can emerge without proper medical treatment.



---

## AVOID PINCH POINTS

**⚠ WARNING** Moving parts or the mishandling of parts can cause severe personal injury.

Keep hands away from moving parts.

Watch your fingers, hands, and legs while equipment is in operation.

Handle parts carefully to avoid crushing and pinch point hazards.

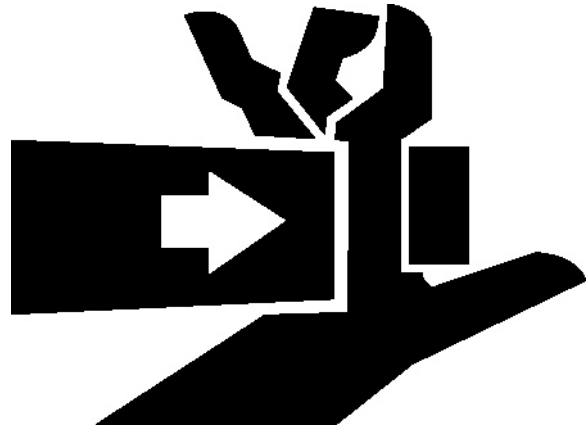

---

## UNAUTHORIZED WELDING

**⚠ WARNING** Unauthorized welding can cause structural failure resulting in possible injury or death.

Do not weld on any structural member. Unauthorized welding or repair will void the warranty.

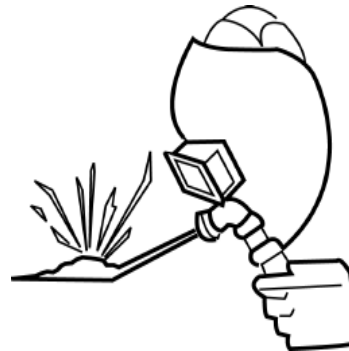

## MAINTENANCE CHARTS

Use the item number in the chart to refer to the detailed maintenance procedures later in this section.

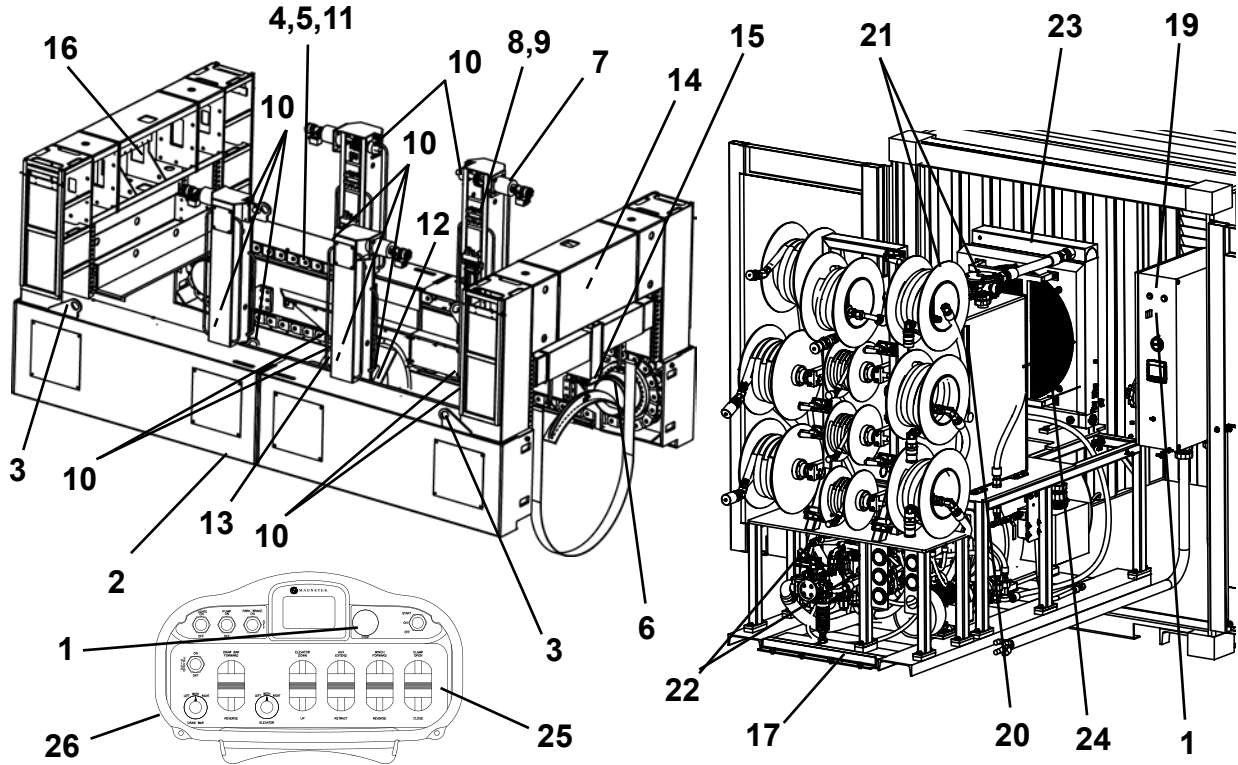

**PRIOR TO EACH JOB LAUNCH**

ITEM	COMPONENT	SERVICE	REQUIREMENT	MATERIAL
1.	E-Stop	Check Operation	E-Stop- Power Pack & Controller	
2.	Sliplining Frame	Inspect	If damaged, repair prior to use.	
3.	Lift Eyes	Inspect	If damaged, repair or replace prior to use.	
4.	Main Drive Chain	Inspect For Damage/Lubricate		SAE 90 Gear Oil
5.	Main Drive Chain	Check Tension		
6.	Drive Motor Gearbox	Check Level & Condition	Refill or replace as needed.	Mobil SHC 630
7.	Elevator Mtr. Gearbox	Check Level	Refill or replace as needed.	Mobil SHC 630
8.	Elevator Chain	Inspect For Damage/Lubricate		SAE 90 Gear Oil
9.	Elevator Chain	Check Tension	Deflection 1/2"-1"	
10.	Elevator Bearing	Lubricate (12 Places)	Lubricate until grease is forced out.	Mobil XHP222
11.	Tension Rod Link	Lubricate (4 Places)	Lubricate until grease is forced out.	Mobil XHP222
12.	Drawbar Pin	Lubricate	Lubricate until grease is forced out.	Mobil XHP222
13.	Drawbar Vertical Lead Block	Lubricate	Lubricate until grease is forced out.	Mobil XHP222
14.	Crossover Channel Lead Block	Lubricate	Lubricate until grease is forced out.	Mobil XHP222
15.	Pipe Clamp	Lubricate (3 Places)	Lubricate until grease is forced out.	Mobil XHP222
16.	Winch Cable	Inspect For Damage	If damaged, replace with new.	
17.	Power Pack Frame	Inspect	If damaged, repair or replace.	
*18.	Elect/Hyd Connect.	Check	Connections must be secured.	
19.	Phase Power	Check		
20.	Hydraulic Oil	Check Level & Condition	Refill or replace as needed.	ISO-VG-68
21.	Hyd. Return Filters	Check	Replace filters per indicator.	Return Filters
22.	Hydrostatic Pump	Replace Filters (2)	Replace before launch.	
23.	Oil Cooler	Clean	As needed.	
24.	Cooling Fan	Clean & Inspect		
25.	Controls	Check Operation		
26.	Pendant Battery	Check	Recharge battery as needed.	
*27.	Decals	Inspect	Must be legible. Replace as needed.	

\* Not Shown  
050163\_slipliningssystem-om

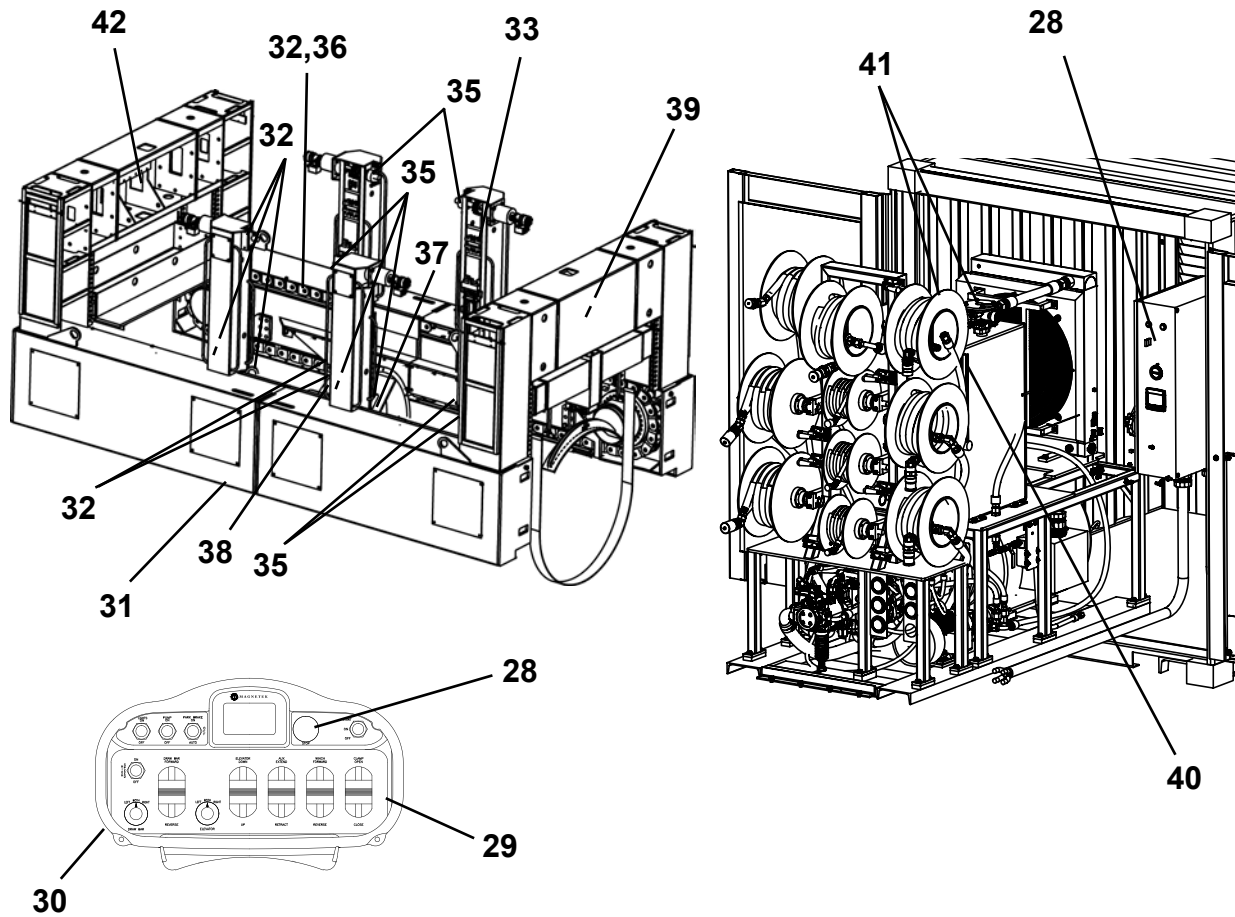

**DAILY OR EVERY 10 HOURS OF OPERATION OR SHIFT CHANGE**

ITEM	COMPONENT	SERVICE	REQUIREMENT	MATERIAL
28.	E-Stop	Check Operation	E-Stop- Power Pack & Pendant	
29.	Controls	Check For Proper Operation		
30.	Pendant Battery	Check	Recharge battery as needed.	
31.	Structure	Inspect For Cracks/Wear	Repair before operation.	
32.	Main Drive Chain	Inspect For Damage/Lubricate		SAE 90 Gear Oil
33.	Elevator Chain	Inspect For Damage/Lubricate		SAE 90 Gear Oil
*34.	Hoses/Pwr Cables	Inspect	Replace if damaged before operating.	
35.	Elevator Bearing	Lubricate (12 Places)	Lubricate until grease is forced out.	Mobil XHP222
36.	Tension Rod Link	Lubricate (4 Places)	Lubricate until grease is forced out.	Mobil XHP222
37.	Drawbar Pin	Lubricate	Lubricate until grease is forced out.	Mobil XHP222
38.	Drawbar Vertical Lead Block	Lubricate	Lubricate until grease is forced out.	Mobil XHP222
39.	Crossover Channel Lead Block	Lubricate	Lubricate until grease is forced out.	Mobil XHP222
40.	Hydraulic Oil	Check Level	Refill as needed.	ISO-VG-68
41.	Hyd. Return Filters	Check Filter Indicators	Replace filters per indicator.	Return Filters
42.	Winch Cable	Inspect For Damage	If damaged, replace with new.	

\* Not Shown

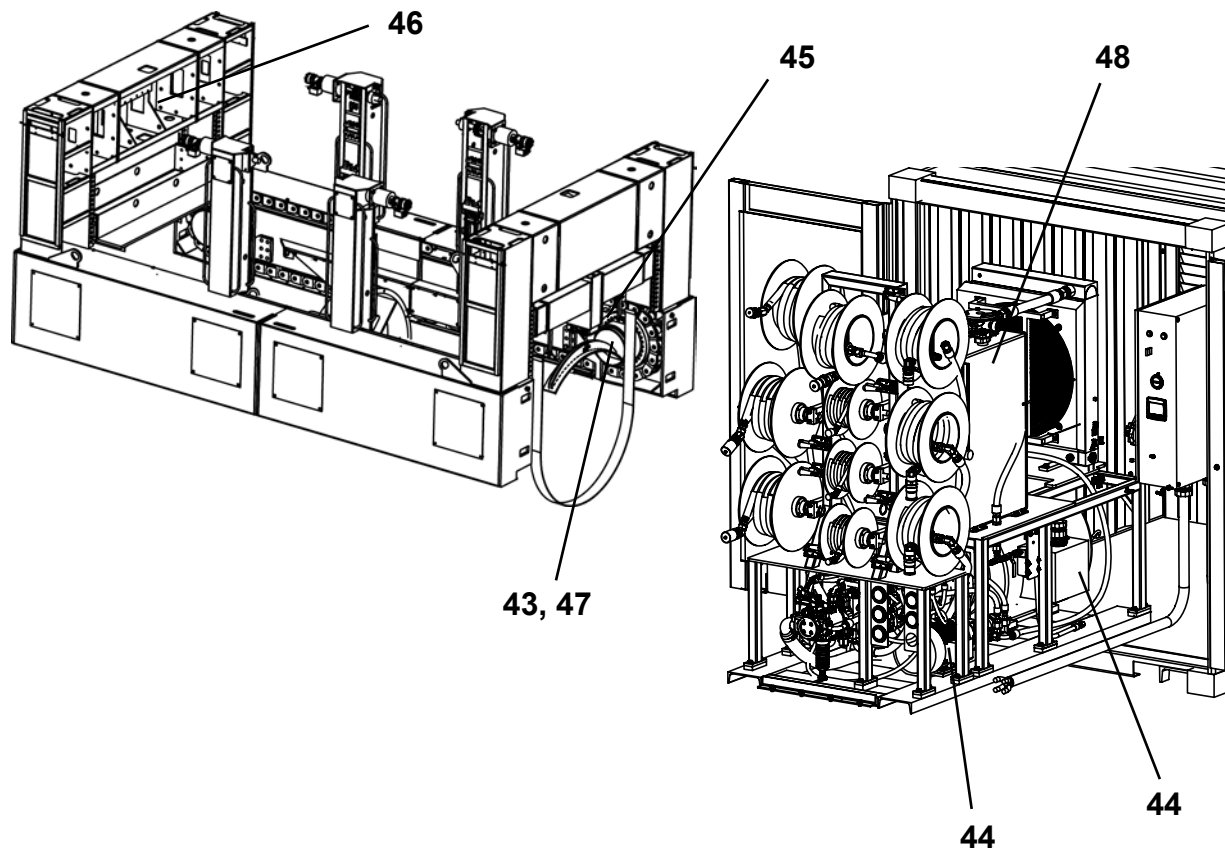

**WEEKLY OR EVERY 50 HOURS OF OPERATION**

ITEM	COMPONENT	SERVICE	REQUIREMENT	MATERIAL
43. 44.	Drive Motor Gearbox Motor	Check Level & Condition Check	Refill or replace as needed. Ventilation openings clean and drain holes open.	
45.	Pipe Clamp	Lubricate (3 Places)	Lubricate until grease is forced out.	Mobil XHP222

**EVERY 100 HOURS OF OPERATION**

ITEM	COMPONENT	SERVICE	REQUIREMENT	MATERIAL
46.	Winch Gear Case	Drain and Replace	Drain and fill with new oil.	80W90 Gear Oil

**FIRST 150 HOURS OF OPERATION, THEN EVERY 1000 HOURS THEREAFTER**

ITEM	COMPONENT	SERVICE	REQUIREMENT	MATERIAL
47.	Drive Motor Gearbox	Drain and Replace	Drain and fill with new oil.	Mobil SHC 630

**MONTHLY OR EVERY 250 HOURS OF OPERATION**

ITEM	COMPONENT	SERVICE	REQUIREMENT	MATERIAL
48.	Pwr Pack Oil Analysis	Perform Analysis	Oil Sample	

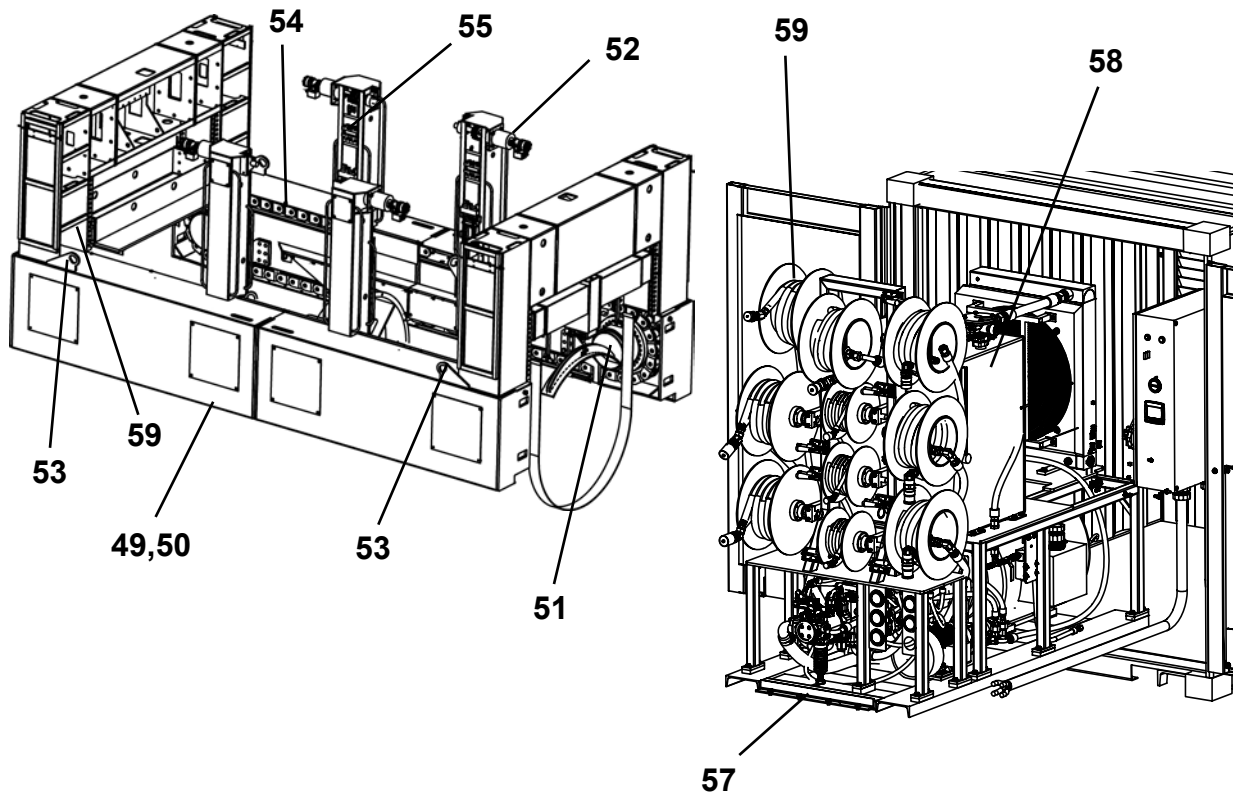

**COMPLETION OF EACH DRIVE**

ITEM	COMPONENT	SERVICE	REQUIREMENT	MATERIAL
49.	Frame	Pressure Wash		
50.	Structure	Inspect For Cracks/Wear	Repair before operation.	
51.	Drive Motor Gearbox	Check Level & Condition	Refill or replace as needed.	Mobil SHC 630
52.	Elevator Mtr. Gearbox	Check Level	Refill or replace as needed.	Mobil SHC 630
53.	Lift Eyes	Inspect	Repair or replace before lifting.	
54.	Main Drive Chain	Clean	Clean & spray LPS® 3 on chain.	
55.	Elevator Chain	Clean	Clean & spray LPS® 3 on chain.	
*56.	Hoses/Pwr Cables	Inspect	Replace if damaged before operating.	
57.	Power Pack Frame	Inspect	If damaged, repair or replace.	
58.	Hydraulic Reservoir	Drain Water	Drain until water is removed.	
59.	Case Drain Thermal Relief Tank	Connect Frame Case Drain To Relief Tank QD		

\* Not Shown

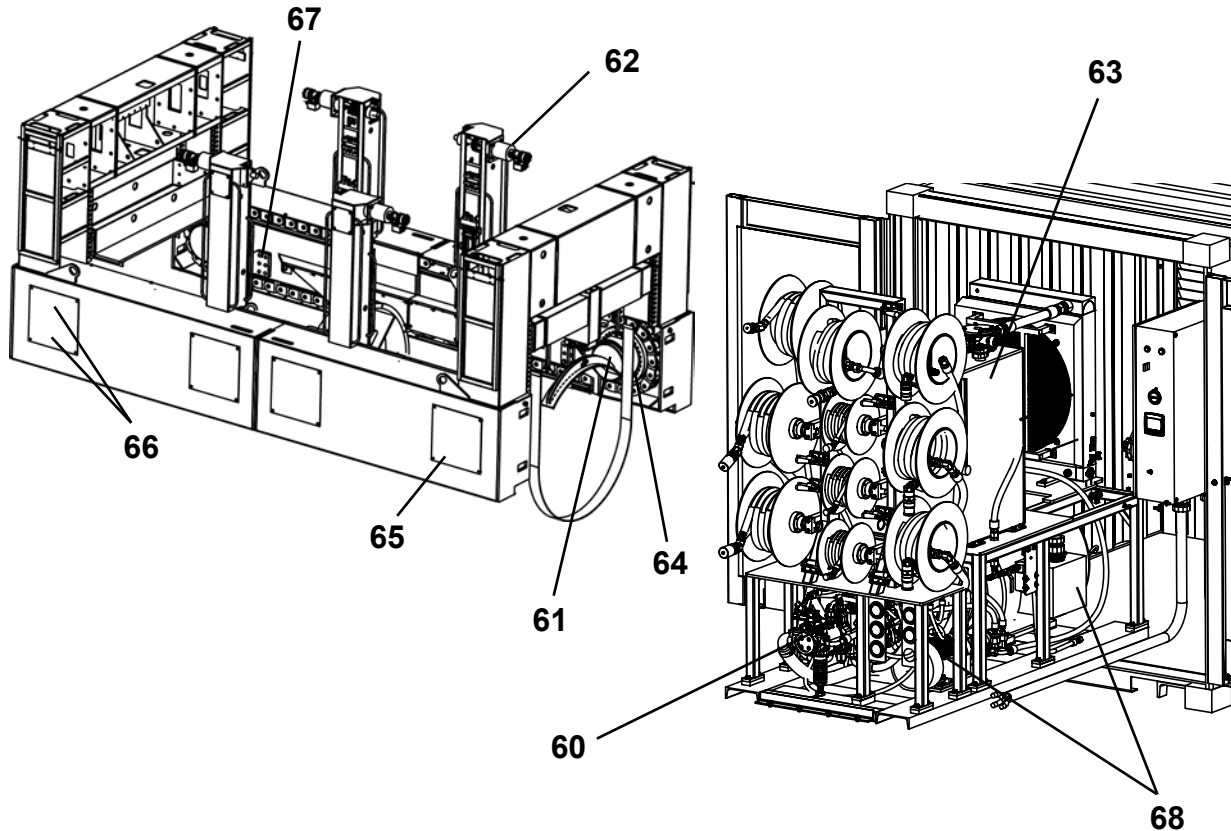

**EVERY 500 HOURS OF OPERATION**

ITEM	COMPONENT	SERVICE	REQUIREMENT	MATERIAL
60.	Load Sense Filter	Replace (1 place)	Replace with new.	LS Filter

**EVERY 1000 HOURS OF OPERATION**

ITEM	COMPONENT	SERVICE	REQUIREMENT	MATERIAL
61.	Drive Motor Gearbox	Drain & Fill	Drain and fill with new oil.	Mobil SHC 630
62.	Elevator Mtr Gearbox	Drain & Fill	Drain and fill with new oil.	Mobil SHC 630
63.	Hydraulic Reservoir	Drain & Fill	Drain and fill with new oil.	ISO-VG-68
64.	Drive Sprocket Mounting Bolts	Check Bolt Tightness (128 places)	Tighten to 630 ft.-lb. torque.	Torque Wrench
65.	Final Drive Mounting Bolts	Check Bolt Tightness (128 places)	Tighten to 630 ft.-lb. torque.	Torque Wrench
66.	Drive Motor Mounting Bolts	Check Bolt Tightness (8 places)	Tighten to 250 ft.-lb. torque.	Torque Wrench
*67.	Drawbar Stop Mounting Bolts	Check Bolt Tightness (24 places)	Tighten to 680 ft.-lb. torque.	Torque Wrench

\* If a hard impact on a drawbar stop occurs, check the mounting bolt tightness.

**ANNUALLY**

ITEM	COMPONENT	SERVICE	REQUIREMENT	MATERIAL
68.	Electric Motor Brgs.	Lubricate (2 places)	2 Shots	Mobil Polyrex EM

## PRIOR TO EACH JOB LAUNCH

### 1. CHECK EMERGENCY STOP OPERATION

**⚠ WARNING** Emergency Stop (E-Stop) buttons MUST function properly BEFORE operating the sliplining system. Failure to do so may cause severe injury or death.

Check E-Stop buttons (A and B) for proper operation. When pushed in, The E-Stop must stop electrical motor rotation, control system functions and hydraulic power. Be sure to check the function of both E-Stop buttons; the controller and the power pack.

The button will function as follows:

- STOP - Push button IN
- Power for Start Circuit - Pull button OUT



*Controller E-Stop Button (A)*

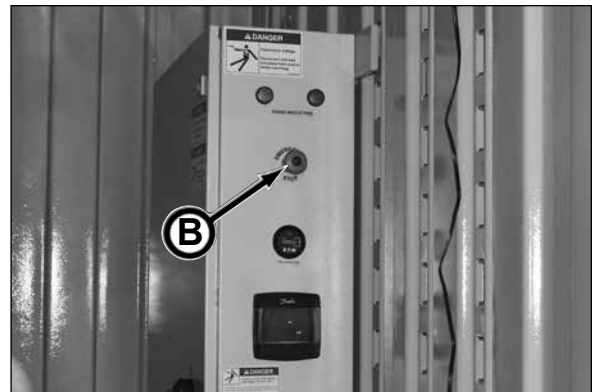

*Power Pack E-Stop Button (B)*

### 2. INSPECT SLIPLINING FRAME

Perform a visual inspection of the sliplining frame for cracks, wear or other damage. Repair or replace BEFORE operation.

Check for oil leaks and debris buildup. Make repairs as needed and remove debris.

Check for loose, damaged or missing parts. Repair or replace as necessary. Replace any defective parts.

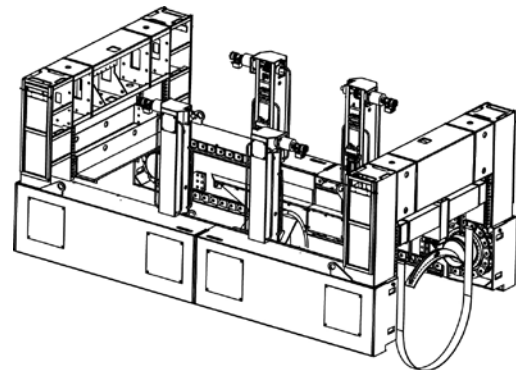

### 3. INSPECT LIFTING EYES

Inspect lifting eyes (C) for wear or damage. Worn or damaged lifting eyes MUST be replaced before lifting.

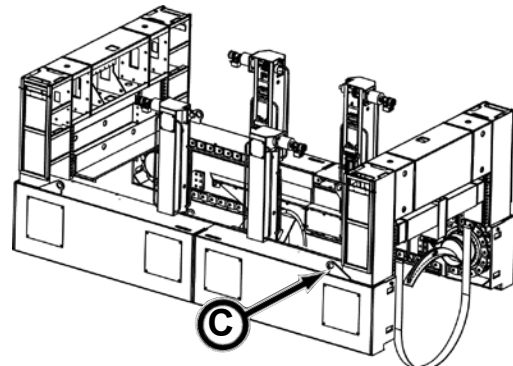

#### 4. INSPECT & LUBRICATE MAIN DRIVE CHAIN

Inspect main drive chain (A) for wear or damage. Repair or replace BEFORE operation.

Apply SAE 90 gear oil (Schedule 220) lubricant on the drive chain.

Repeat for main drive chain on opposite side of unit.

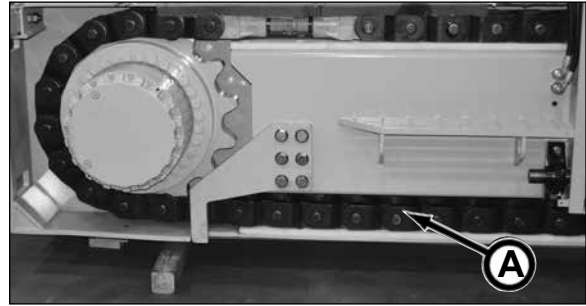

#### 5. CHECK MAIN DRIVE CHAIN TENSION

Check the main drive chain tension.

If the drive chain appears to be loose, tensioning is required:

1. Remove guard to gain access to chain tensioner (B).
2. Remove locking bar (C).
3. Remove drive chain tension adjustment tool (D) from storage location.
4. Insert drive chain tension adjustment tool into tensioner to tighten chain.
5. Replace and secure locking bar.
6. Replace guard.

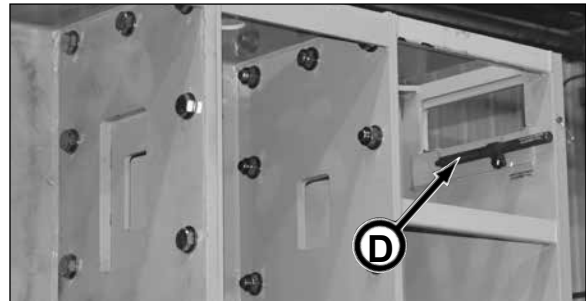
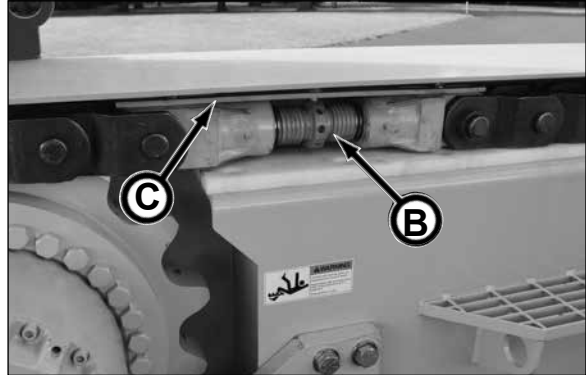

#### 6. CHECK DRIVE MOTOR GEARBOX OIL CONDITION & LEVEL

##### ***Check the drive motor gearbox oil condition:***

1. Clean area around the ports.
2. Drain a measured sampling of the gearbox oil.
3. Inspect the drained oil for contaminants.
4. Repeat for the other three drive motor gearboxes.

• If water is visible in the oil, seals are damaged and must be replaced

• With any contamination, the gear box must be completely drained and refilled with fresh, clean Mobil SHC™ 630 Synthetic Bearing and Gear oil.

##### ***Check the drive motor gearbox oil level:***

1. Position the gearbox with the fill port (E) at the 12 o'clock position and the check port at the 3 o'clock or 9 o'clock position.
2. Remove the check plug (F). If the oil is not visible at the check port level, add fresh, clean Mobil SHC™ 630 Synthetic Bearing and Gear oil in the fill port until the oil is level with the check port.
3. Repeat for the three other drive motor gearboxes.

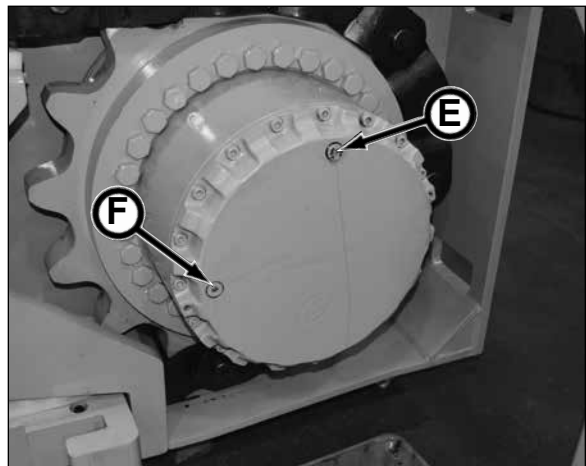

### 7. CHECK ELEVATOR MOTOR GEARBOX OIL LEVEL

Remove the check plug (A). If the oil is not visible at the check port level, add fresh, clean Mobil SHC™ 630 Synthetic Bearing and Gear oil in the fill port (B) until the oil is level with the check port.

Repeat for the other three elevator motor gearboxes.

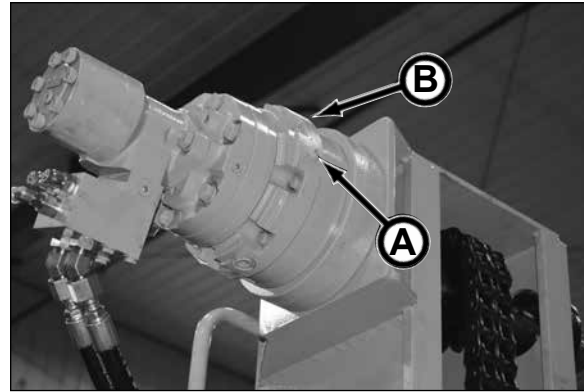

### 8. INSPECT & LUBRICATE ELEVATOR CHAIN

Inspect elevator chain (C) for wear or damage. Repair or replace BEFORE operation.

Apply SAE 90 gear oil (Schedule 220) lubricant on the drive chain.

Repeat for the other three elevator chains.

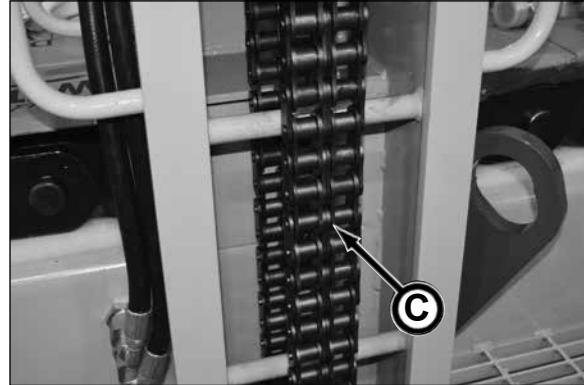

### 9. CHECK ELEVATOR CHAIN TENSION

Check the elevator chain tension. If the elevator chain appears to be loose, tensioning is required:

1. Remove access door (D) on the outside of the elevator tower.
2. Move elevator chain tensioning assembly so it can be adjusted through the access door.
3. Loosen jam nuts (E).
4. Tighten chain with adjustment screws (F) so the chain has a 1/2" to 1" (12.7 - 25.4 mm) deflection.
5. Tighten jam nuts.
6. Replace access door.
7. If needed, repeat steps 1 through 6 for other elevator chains.

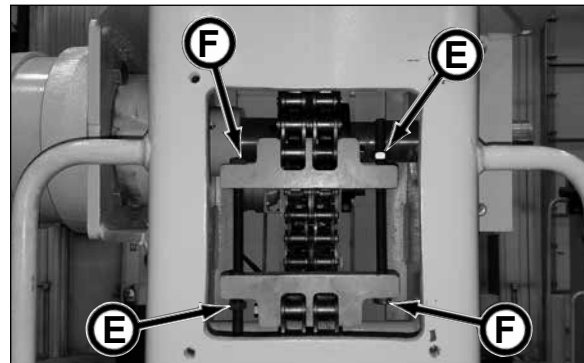
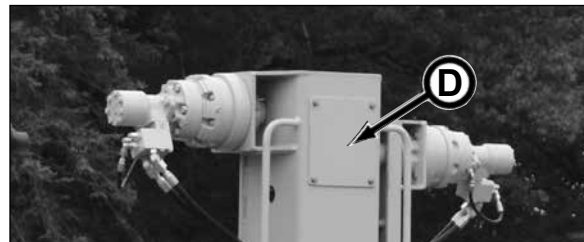

### 10. LUBRICATE ELEVATOR SHAFT BEARINGS

Lubricate elevator shaft bearings (G) (12 places) with Mobilgrease® XHP222 or equivalent until grease is forced out.

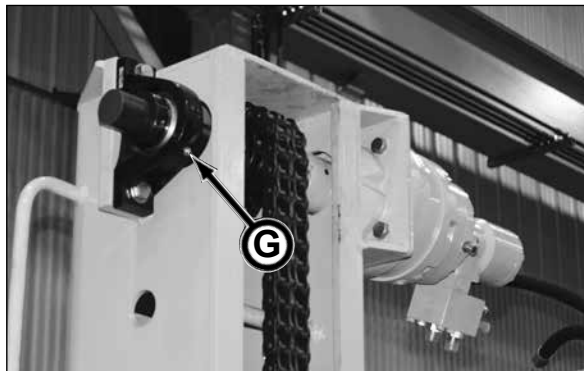

### 11. LUBRICATE CHAIN TENSION ROD LINK

Lubricate chain tension rod links (A) (4 places) with Mobilgrease® XHP222 or equivalent until grease is forced out.

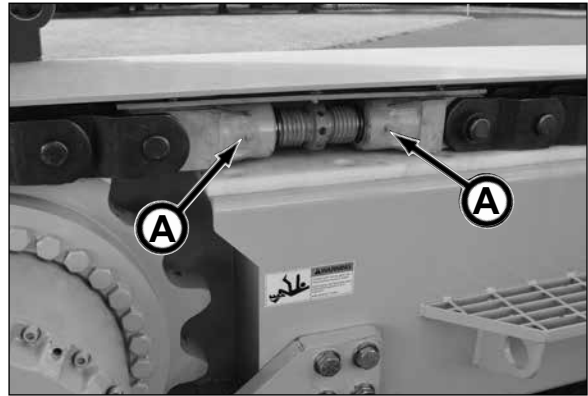

### 12. LUBRICATE DRAWBAR PIN

Lubricate drawbar pin (B) with Mobilgrease® XHP222 or equivalent until grease is forced out.

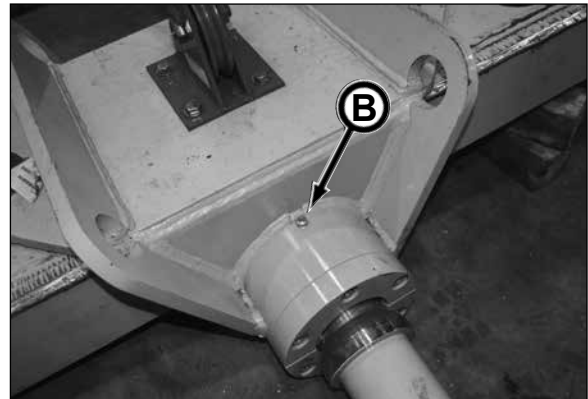

### 13. LUBRICATE DRAWBAR VERTICAL LEAD BLOCK

Lubricate drawbar vertical lead block (C) with Mobilgrease® XHP222 or equivalent until grease is forced out.

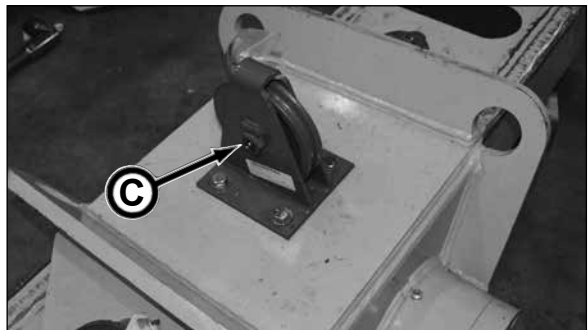

### 14. LUBRICATE CROSSOVER CHANNEL LEAD BLOCK

Lubricate crossover channel lead block (D) with Mobilgrease® XHP222 or equivalent until grease is forced out.

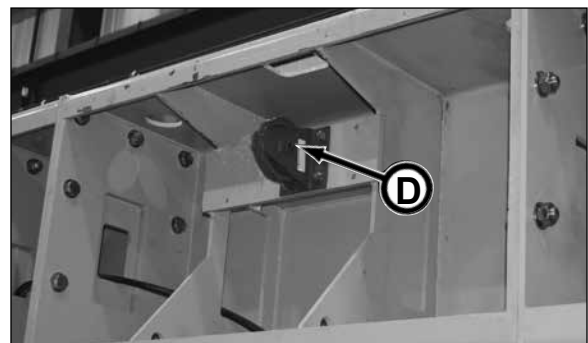

### 15. LUBRICATE PIPE CLAMP ASSEMBLY

Lubricate pipe clamp assembly (E) (3 places) with Mobilgrease® XHP222 or equivalent until grease is forced out.

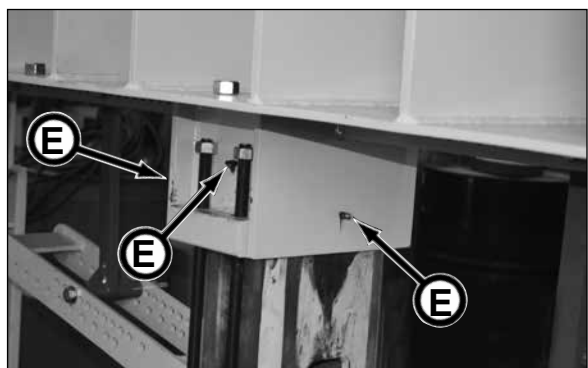

## 16. INSPECT WINCH CABLE

Inspect winch cable (A) for kinks, fraying, broken strands or other damage. Replace cable if damaged prior to use.

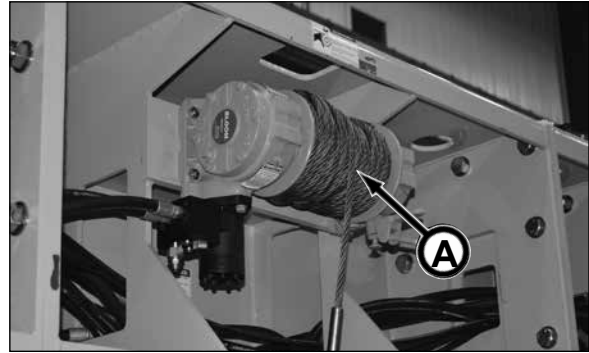

## 17. INSPECT POWER PACK FRAME

Perform a visual inspection of the power pack. Inspect structures, mountings and lubricant levels.

Immediately report any structural problems to your Akkerman aftermarket support representative.

Check for oil leaks and debris buildup. Make repairs as needed and remove debris.

Check for loose, damaged, or missing parts. Repair or replace as necessary. Replace any defective parts.

Tighten hardware as needed. Do not over-tighten hardware.

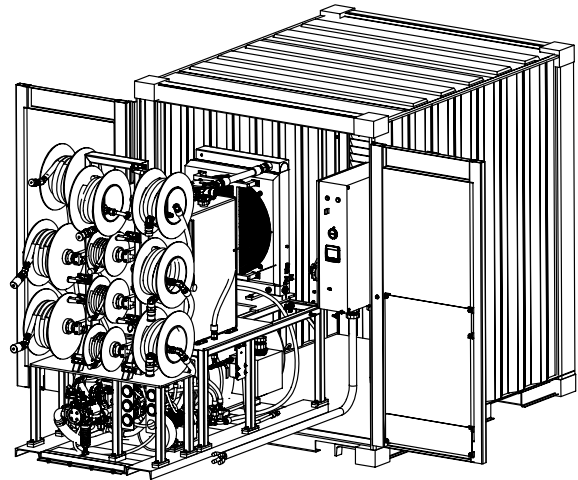

## 18. INSPECT HYDRAULIC HOSES & POWER CABLES

**⚠ DANGER** If high voltage cables or cable connections are frayed, worn or damaged, contact with cables/connections will result in electrical shock causing severe injury or death.

With power in LOCK OUT, TAG OUT, check electrical power cables and connections for fraying, wear or damage. If damaged, the cables must be replaced BEFORE operation.

Inspect ALL hydraulic hoses for cracks, wear or other damage. Repair or replace BEFORE operation.

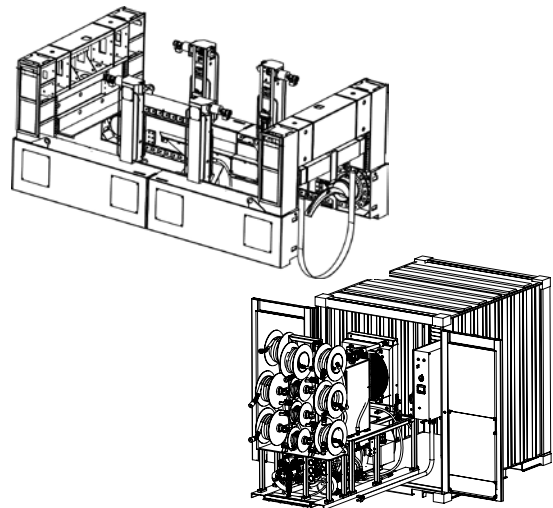

## 19. CHECK PHASE POWER

The input power on the power pack is monitored for proper three phase electrical power on each power pressure module. The green Phase OK indicator must be illuminated before operating equipment.

**IMPORTANT: If the red Phase Error indicator is illuminated, the power pressure module starting is disabled. This starting interlock will prevent the components from running backwards which would result in damage.**

If the green Phase OK indicator (A) is illuminated, this indicates that the external power source phase power is installed correctly and the main power can be turned on.

If the red Phase Error indicator (B) is illuminated, this indicates that the external power source is installed incorrectly. Lockout tagout all power before disconnecting power lead cables. Have a certified electrician reverse the two generator electrical phase conductors on the power circuit and recheck phase power.

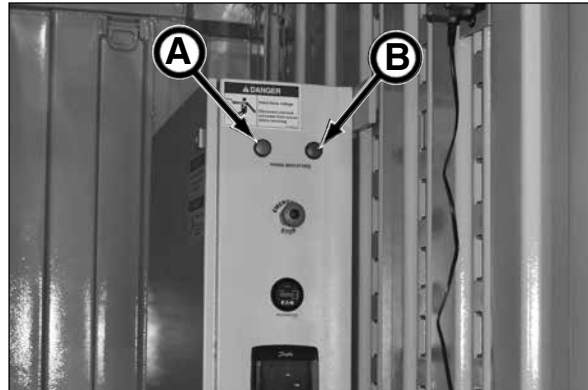

## 20. CHECK POWER PACK HYDRAULIC OIL RESERVOIR CONDITION & LEVEL OF OIL

1. Check reservoir hydraulic oil for the following:

- a. Check for oil bubbles or foaming oil. This may indicate an air leak in the system.
- b. Check for milky oil. This indicates that there is water in the system. Be sure your oil is being properly stored.
- c. Large particle contamination from oil sample.

If any of these conditions are found, the reservoir must be drained, cleaned, and refilled with new, clean filtered hydraulic oil. All hydraulic filters also require replacement. Refer to Every 1000 Hours of Operation, "61. Drain & Fill Hydraulic Oil" in this section.

2. Check the hydraulic reservoir sight gauge (A) for the proper oil level. Keep oil maintained between the low and high marks on the gauge. If needed, add clean, filtered oil to the reservoir.

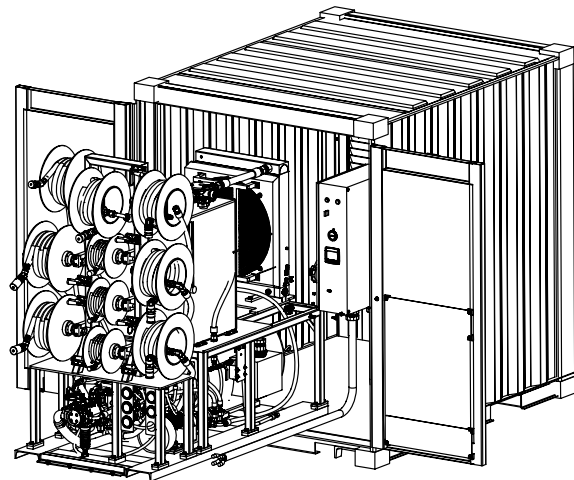

## 21. CHECK HYDRAULIC RETURN FILTER INDICATORS

To prevent over or under servicing of the hydraulic return filters, filter indicators (A) are installed on the filter head assemblies in the power pack.

Always check gauges when the oil is at normal operating temperature and the system is at normal operating flow. Otherwise, the gauges may indicate a false reading.

All filters and oil require replacement if any of the following situations occur:

- A major component fails.
- Any sign of water contamination from an oil analysis or if oil is milky or foaming.
- A hydraulic oil sample indicates large particle contamination.

The green OK zone indicates that the filter is functioning properly.

The yellow zone indicates that the filter will soon require replacement.

When the needle on the gauge is in the red CHANGE zone, replace filter(s) as soon as possible to prevent hydraulic component damage (see Replacing In-Tank Filters below).

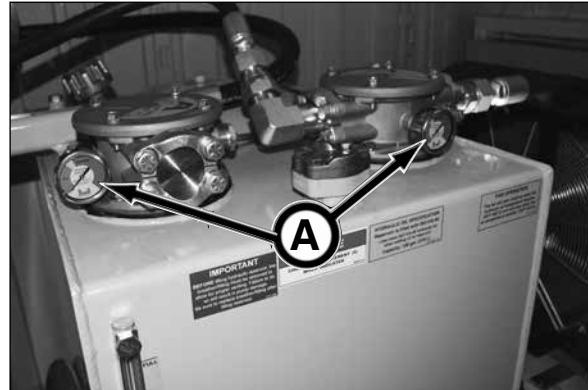

### REPLACING IN-TANK FILTER(S)

1. With power pack shutdown, clean and dry area around the filter head assembly.
2. Remove filter head fasteners and retain for later use.

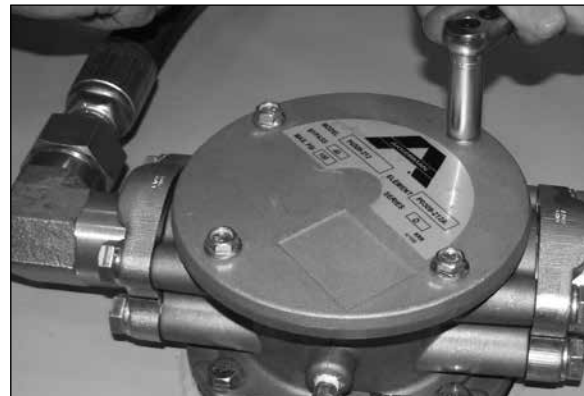

3. Remove head assembly from housing.



*(continued on next page)*

4. Remove filter.
5. Check for metal flakes on filter. If metal flakes are visible, replace all filters and reservoir oil.
6. Dispose of filter properly.



7. Check filter gasket in filter head. If worn or damaged replace with new. Install new gasket (if needed) with a light coat of clean hydraulic oil into filter head. Be sure the gasket is not twisted and is correctly in place.



8. Carefully install new filter into filter housing until it is fully seated into housing.

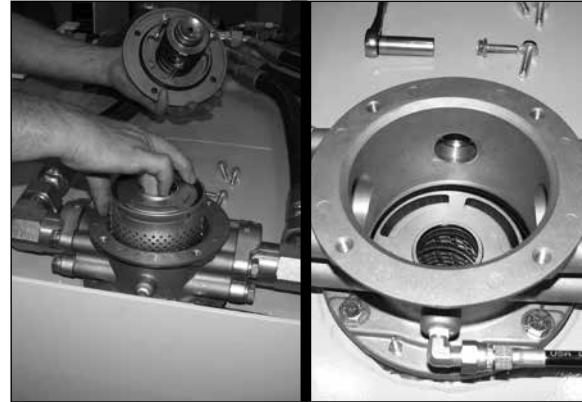

9. Replace filter head assembly onto housing and secure with fasteners removed in step 2.

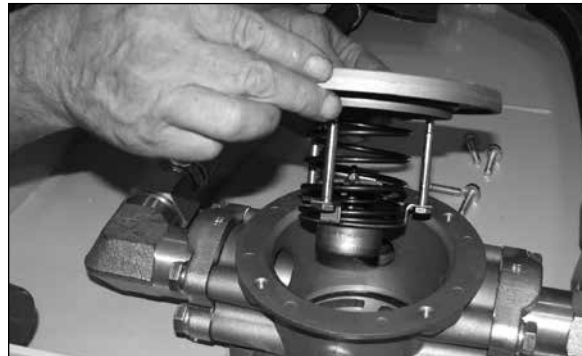

10. Start up power pack and run until hydraulic system is warm, start boring head and jacking motors and check for leaks.
11. Stop motor and shutdown power pack. Replace other filter(s) as needed.



## 22. REPLACE HYDROSTATIC PUMP FILTERS

Replace hydrostatic pump filters Drive 1 (A) and Drive 2 (B) before each drive.

1. Place a catch pan below filter being removed.
2. Remove filter.
3. Install new spin-on filter (hand tighten only).
4. Dispose of oil properly.
5. Replace other filter using steps 2 through 4.

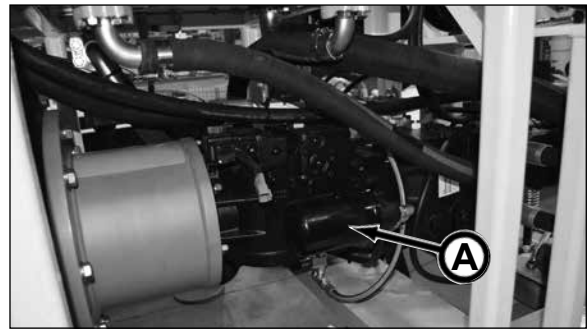

Drive 1 Pump Filter

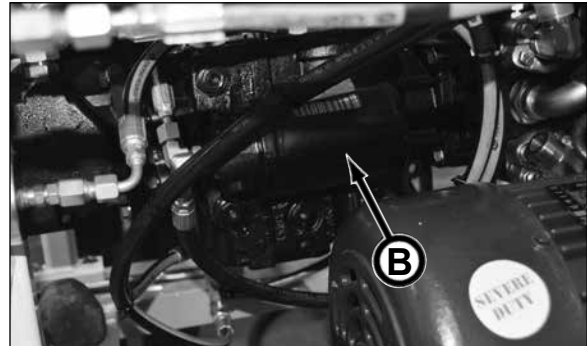

Drive 2 Pump Filter

## 23. CLEAN OIL COOLER

1. Remove louver cover (C) on power pack to gain access to the oil cooler.

**⚠ WARNING** Louver cover is heavy. Use assistance when removing, moving and replacing.

2. Clean oil cooler (D) fins and tubes with compressed air (100 psi maximum).
3. Replace louver and secure with hardware removed in step 1.

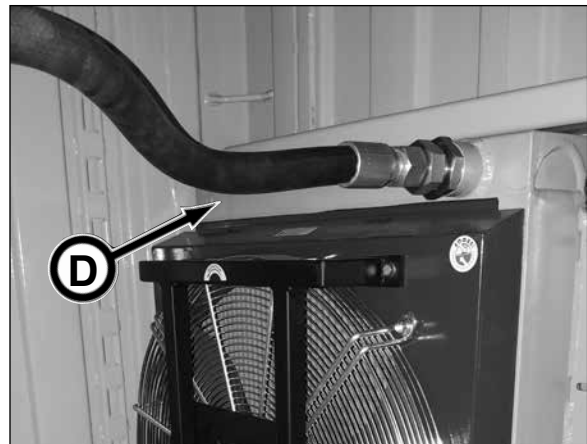
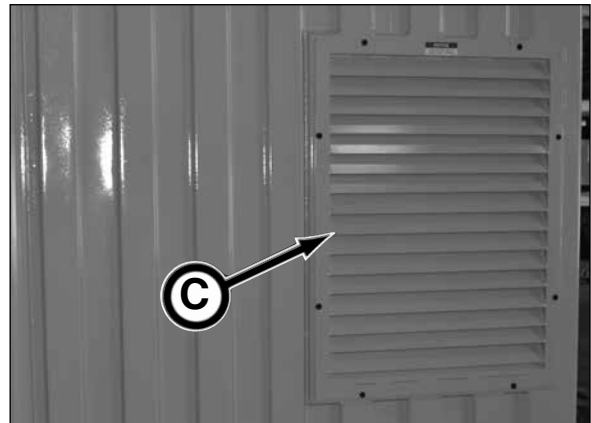

Oil Cooler Assembly Shown From Inside Container

## 24. CLEAN & INSPECT COOLING FAN

**⚠ WARNING** Serious personal injury could result if contact is made with rotating fan blade. Fan blades can rotate at any time power is connected and the main disconnect is in the ON position.

If the power is connected to the power pack and the main disconnect is in the ON position, the fan can rotate anytime the hydraulic oil is at 120°F (49°C) (factory default setting) or someone turns the fan on manually.

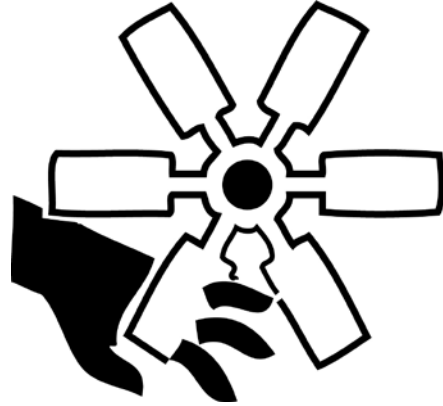

With the main disconnect in the OFF position and Emergency Stop pulled out to prevent accidental starting:

1. Carefully clean cooling fan fins with compressed air (50 psi max.).
2. Check cooling fan (A) for cracks, and bent or loose blades or other damage. If possible straighten fins and blades. Otherwise replace or replace damaged fan.



## 25. CHECK CONTROL OPERATION

**⚠ WARNING** BEFORE checking control operations, be sure all personnel are away from machine. Unexpected movement may cause severe injury or death.

Check power pack and controller controls for proper operation. If controls do not function properly, repair or replace BEFORE operation.

- ALL E-Stop buttons
- Power Pack controls
- Wireless controller functions
- Light operation

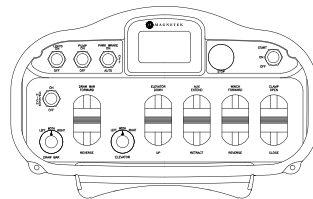
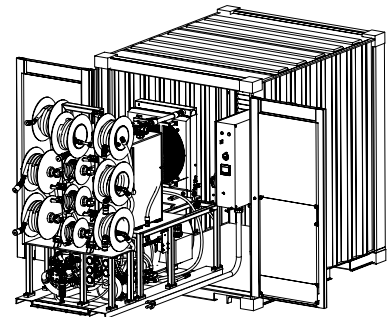

## 26. CHECK PENDANT BATTERY LEVEL

With the wireless remote pendant on, check the pendant battery level (A) on the LCD display. If the level is low, replace battery before operation.

An extra battery is stored on the under side of the pendant assembly.



If charging is required:

1. Flip pendant assembly on its side.
2. Remove pendant power battery door (B).
3. Remove battery.
4. Remove spare battery door (C) and battery. Replace battery door.
5. Install spare battery in pendant power battery compartment. Replace battery door.
6. Place battery to be recharged in battery charger (D) located in the power pack. Power pack must be powered on for charger to function.

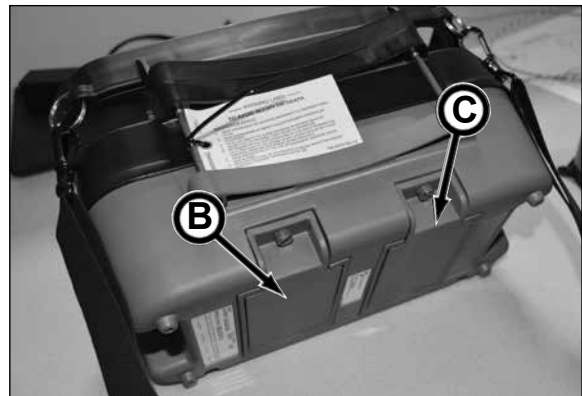

7. With the charger power light (E) on, mount battery into charger. Refer to Status LED (F) on battery charger.

Red light - charging  
Green light - charging complete  
Blink light - error

8. Once battery is charged, replace the battery in the spare battery compartment on the pendant assembly.

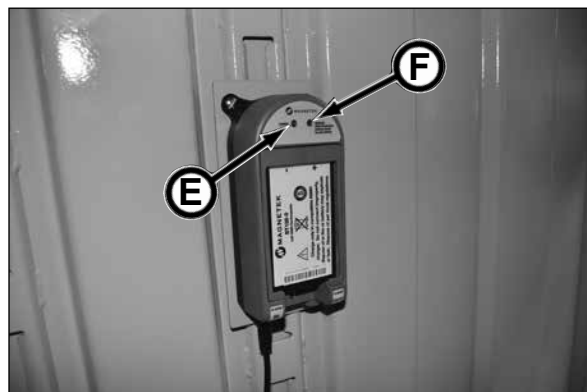
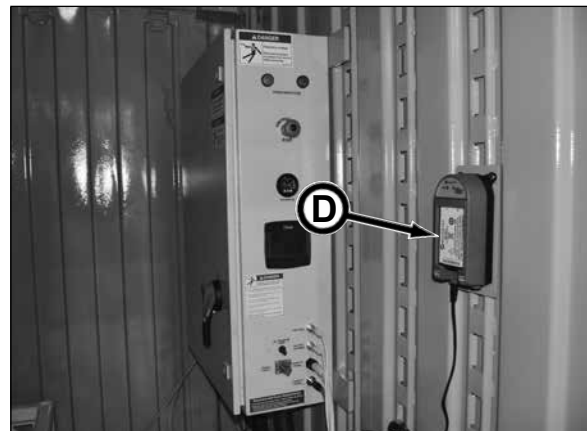

## 27. INSPECT DECALS

Inspect ALL operational and safety decals to be sure they are clean and readable.

Use soft cloth, water, and a mild soap to clean the decals if they are too dirty to read. DO NOT clean decals with solvent. Solvent will damage decals. Replace decals immediately if they are damaged, missing, or hard to read.

Before applying a new decal, be sure the surface is clean and dry.

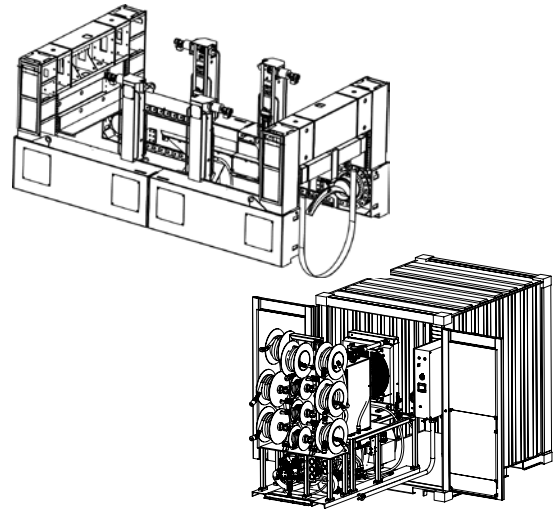

## DAILY OR EVERY 10 HOURS OF OPERATION OR SHIFT CHANGE

### 28. CHECK E-STOP OPERATION

**⚠ WARNING** Emergency Stop (E-Stop) buttons MUST function properly BEFORE operating. Failure to do so may cause severe injury or death.

Check E-Stop buttons (A) for proper operation. When pushed in, the E-Stop will stop the electrical motor rotation, control system functions and hydraulic power.

If E-Stop button does not function properly, it MUST be repaired or replaced BEFORE operation.

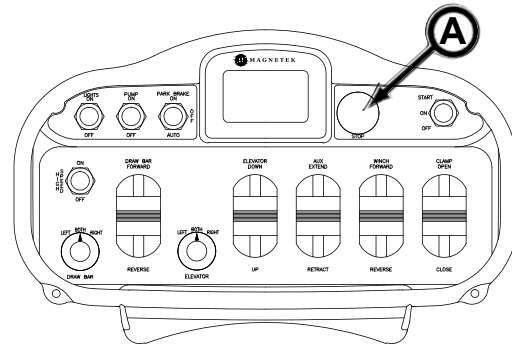

*Slipliner Wireless Remote Pendant E-Stop Button*

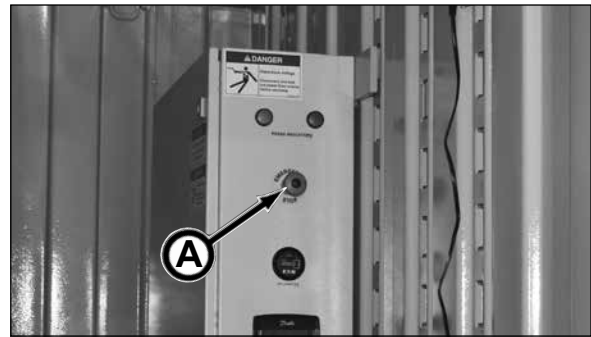

*Power Pack E-Stop Button*

### 29. CHECK CONTROL OPERATION

**⚠ WARNING** BEFORE checking control operations, be sure all personnel are away from machine. Unexpected movement may cause severe injury or death.

Check power pack and controller controls for proper operation. If controls do not function properly, repair or replace BEFORE operation.

- ALL E-Stop buttons
- Power Pack controls
- Wireless controller functions
- Light operation

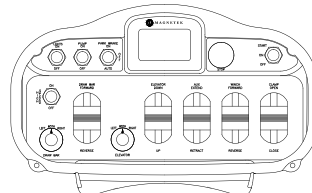
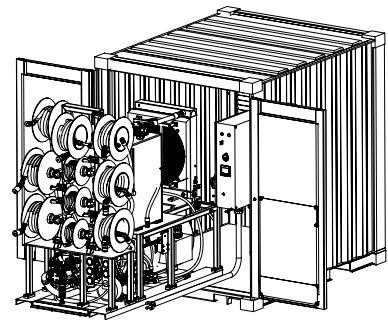

### 30. CHECK PENDANT BATTERY LEVEL

With the wireless remote pendant on, check the pendant battery level (A) on the LCD display. If the level is low, replace battery before operation.

An extra battery is stored on the under side of the pendant assembly.



If charging is required:

1. Flip pendant assembly on its side.
2. Remove pendant power battery door (B).
3. Remove battery.
4. Remove spare battery door (C) and battery. Replace battery door.
5. Install spare battery in pendant power battery compartment. Replace battery door.
6. Place battery to be recharged in battery charger (D) located in the power pack. Power pack must be powered on for charger to function.
7. With the charger power light (E) on, mount battery into charger. Refer to Status LED (F) on battery charger.  
  
Red light - charging  
Green light - charging complete  
Blink light - error
8. Once battery is charged, replace the battery in the spare battery compartment on the pendant assembly.

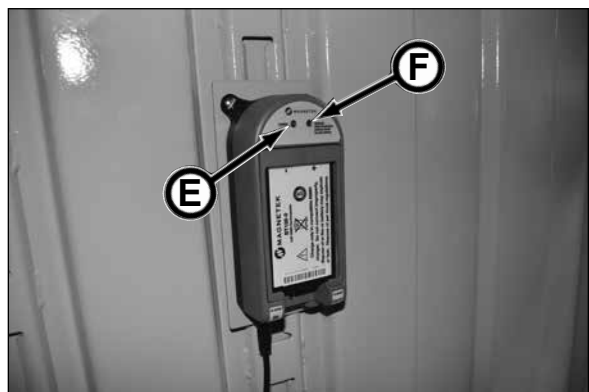
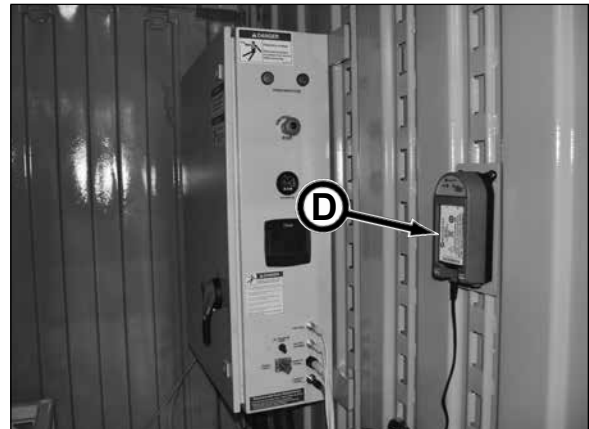
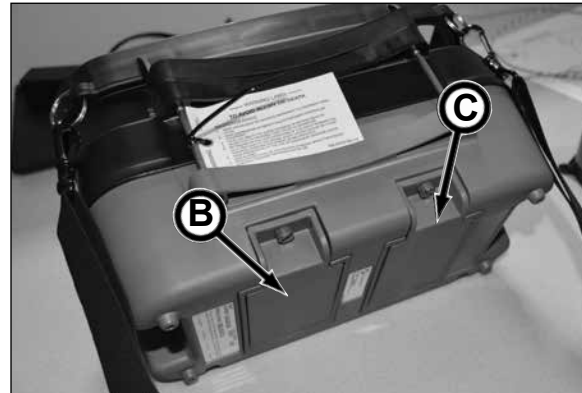

### 31. INSPECT SLIPLINING FRAME

Perform a visual inspection of the sliplining frame for cracks, wear or other damage. Repair or replace BEFORE operation.

Check for oil leaks and debris buildup. Make repairs as needed and remove debris.

Check for loose, damaged or missing parts. Repair or replace as necessary. Replace any defective parts.

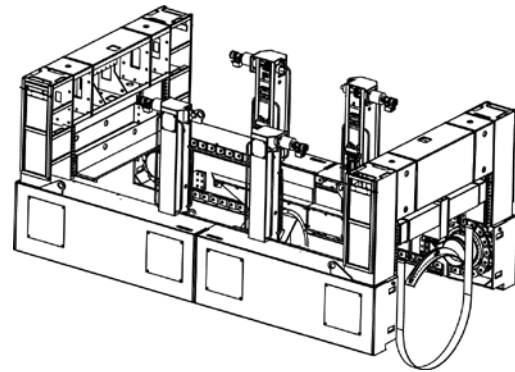

### 32. INSPECT & LUBRICATE MAIN DRIVE CHAIN

Inspect main drive chain (A) for wear or damage. Repair or replace BEFORE operation.

Apply SAE 90 gear oil (Schedule 220) lubricant on the drive chain.

Repeat for main drive chain on opposite side of unit.

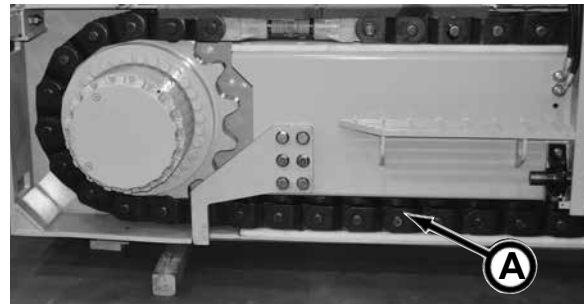

### 33. INSPECT & LUBRICATE ELEVATOR CHAIN

Inspect elevator chain (B) for wear or damage. Repair or replace BEFORE operation.

Apply SAE 90 gear oil (Schedule 220) lubricant on the drive chain.

Repeat for the other three elevator chains.

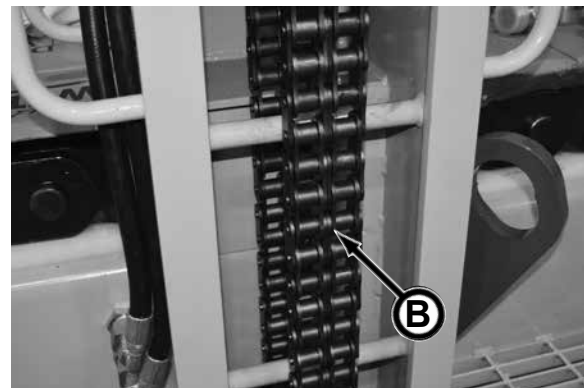

### 34. INSPECT HYDRAULIC HOSES & POWER CABLES

**⚠ DANGER** If high voltage cables or cable connections are frayed, worn or damaged, contact with cables/connections will result in electrical shock causing severe injury or death.

With power in LOCK OUT, TAG OUT, check electrical power cables and connections for fraying, wear or damage. If damaged, the cables must be replaced BEFORE operation.

Inspect ALL hydraulic hoses for cracks, wear or other damage. Repair or replace BEFORE operation.

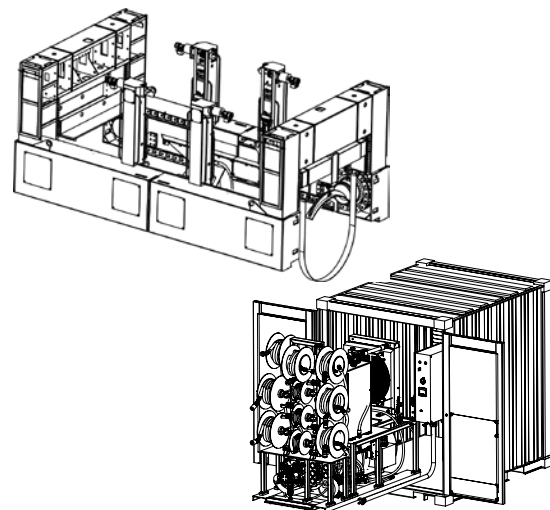

### 35. LUBRICATE ELEVATOR SHAFT BEARINGS

Lubricate elevator shaft bearings (A) (12 places) with Mobilgrease® XHP222 or equivalent until grease is forced out.

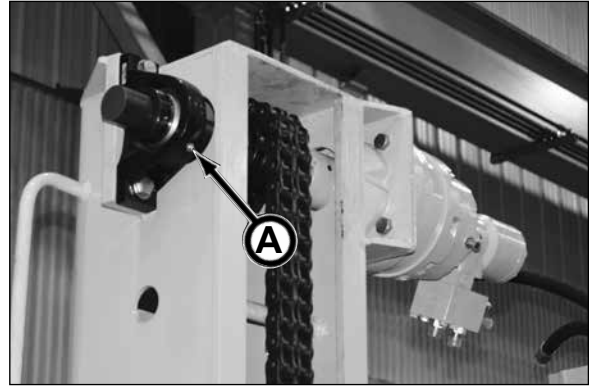

### 36. LUBRICATE CHAIN TENSION ROD LINK

Lubricate chain tension rod links (B) (4 places) with Mobilgrease® XHP222 or equivalent until grease is forced out.

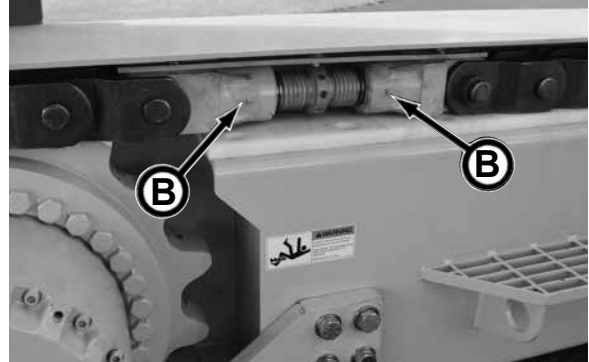

### 37. LUBRICATE DRAWBAR PIN

Lubricate drawbar pin (C) with Mobilgrease® XHP222 or equivalent until grease is forced out.

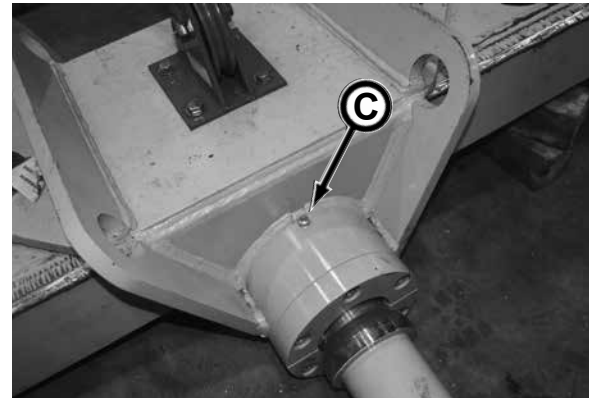

### 38. LUBRICATE DRAWBAR VERTICAL LEAD BLOCK

Lubricate drawbar vertical lead block (D) with Mobilgrease® XHP222 or equivalent until grease is forced out.

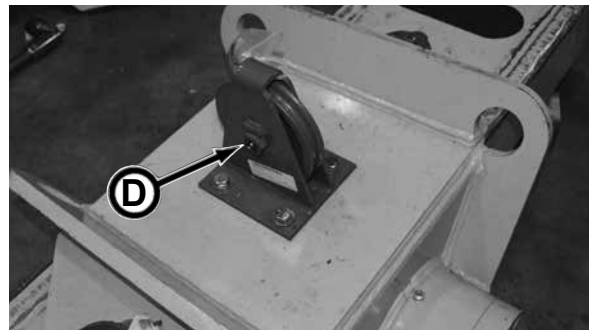

### 39. LUBRICATE CROSSOVER CHANNEL LEAD BLOCK

Lubricate crossover channel lead block (E) with Mobilgrease® XHP222 or equivalent until grease is forced out.

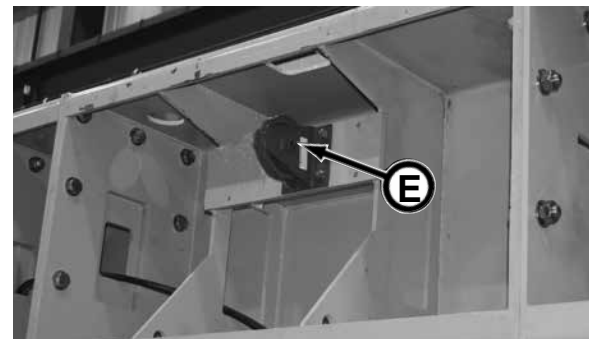

#### 40. CHECK HYDRAULIC RESERVOIR CONDITION & LEVEL OF OIL

1. Check reservoir hydraulic oil for the following:
  - a. Check for oil bubbles or foaming oil. This may indicate an air leak in the system.
  - b. Check for milky oil. This indicates that there is water in the system. Be sure your oil is being properly stored.
  - c. Large particle contamination from oil sample.

If any of these conditions are found, the reservoir must be drained, cleaned, and refilled with new, clean hydraulic oil and all hydraulic filters must be replaced. Refer to Every 1000 Hours of Operation, "61. Drain & Fill Hydraulic Oil" in this section.

2. Check hydraulic tank oil level gauge (A).

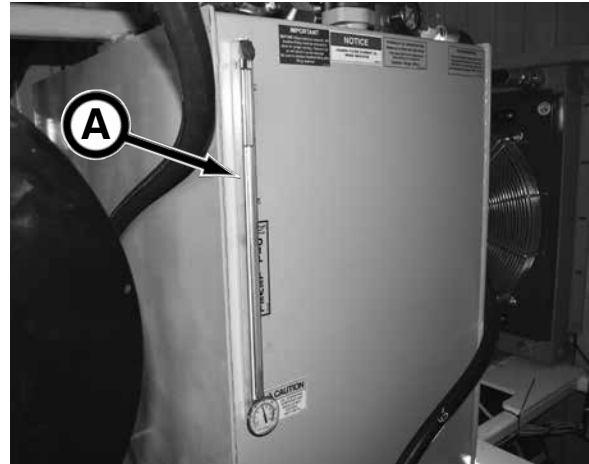

#### FILLING RESERVOIR

If the fluid level in the reservoir is less than 3/4 full, fill the reservoir with ISO-VG-68 Premium Hydraulic Turbine Oil as follows:

1. Remove hydraulic oil fill hose from storage location. Remove cap from hose.



2. Place hose into hydraulic oil container.

**NOTICE** Refer to Fuels & Lubricants section for recommended hydraulic oil.



3. Open hydraulic fill shut off valve by moving handle up to the 3 o'clock position.



**IMPORTANT: BEFORE** filling hydraulic reservoir, the breather/fitting must be removed to allow for proper venting. Failure to do so will result in pump damage. Be sure to replace breather/fitting after filling reservoir.

4. Remove breather/fitting (A) from reservoir BEFORE filling reservoir to allow for proper venting during filling process.

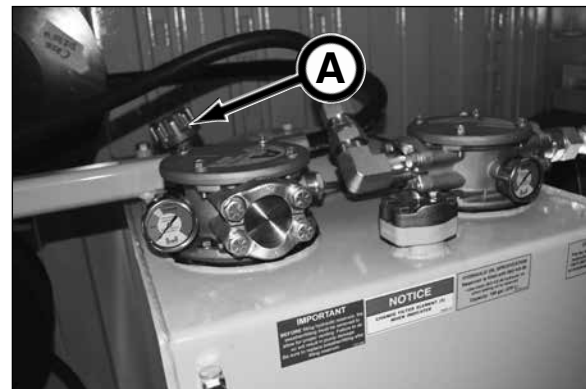

5. Flip Oil Transfer Pump switch in the power pack up to the ON position to pump hydraulic oil into the hydraulic reservoir.

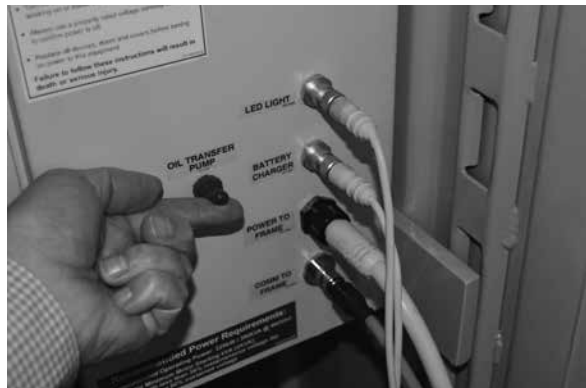

(continued on next page)

6. Fill until oil reaches the high mark on gauge (A).

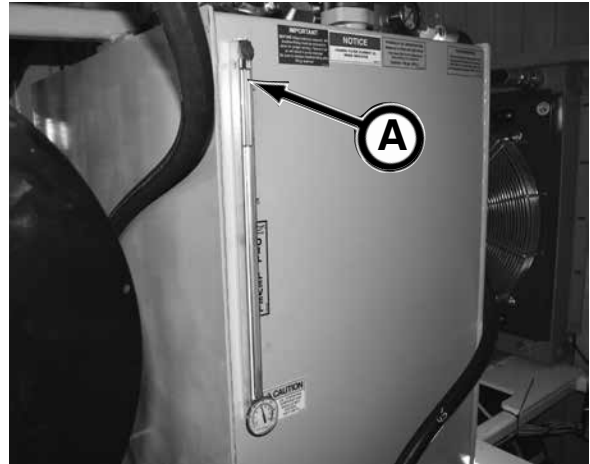

7. Flip Oil Transfer Pump switch down to the OFF position.



8. Replace breather/fitting (B) on reservoir.

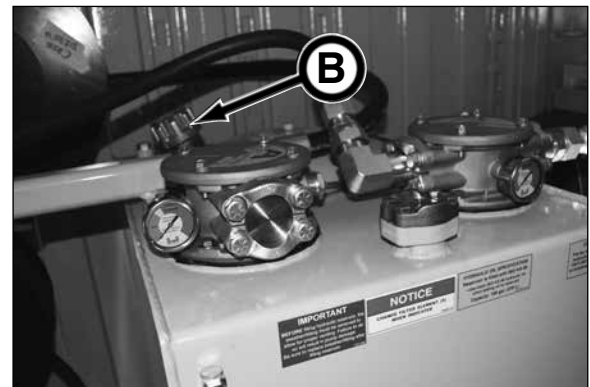

9. Close hydraulic fill shut off valve by moving handle down to the 6 o'clock position.

10. Replace cap on fill hose and place hose in storage location.



#### 41. CHECK HYDRAULIC FILTER INDICATORS

To prevent over or under servicing of the hydraulic return filters, filter indicators (A) are installed on the filter head assemblies in the power pack.

Always check gauges when the oil is at normal operating temperature and the system is at normal operating flow. Otherwise, the gauges may indicate a false reading.

All filters and oil require replacement if any of the following situations occur:

- A major component fails.
- Any sign of water contamination from an oil analysis or if oil is milky or foaming.
- A hydraulic oil sample indicates large particle contamination.

The green OK zone indicates that the filter is functioning properly.

The yellow zone indicates that the filter will soon require replacement.

When the needle on the gauge is in the red CHANGE zone, replace filter(s) as soon as possible to prevent hydraulic component damage (see Replacing In-Tank Filters below).

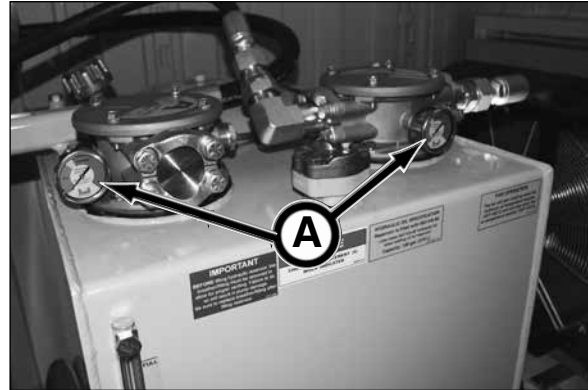

#### REPLACING IN-TANK FILTER(S)

1. With power pack shutdown, clean and dry area around the filter head assembly.
2. Remove filter head fasteners and retain for later use.

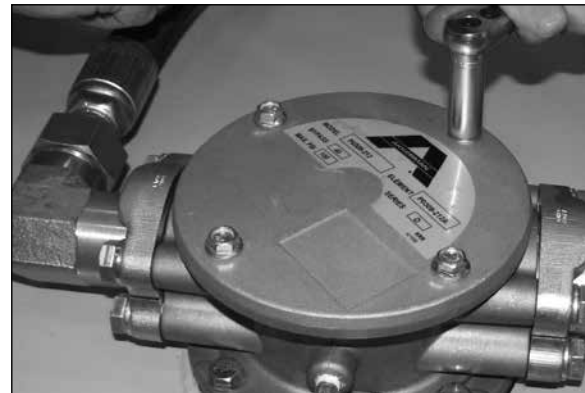

3. Remove head assembly from housing.



*(continued on next page)*

4. Remove filter.
5. Check for metal flakes on filter. If metal flakes are visible, replace all filters and reservoir oil.
6. Dispose of filter properly.



7. Check filter gasket in filter head. If worn or damaged replace with new. Install new gasket (if needed) with a light coat of clean hydraulic oil into filter head. Be sure the gasket is not twisted and is correctly in place.



8. Carefully install new filter into filter housing until it is fully seated into housing.

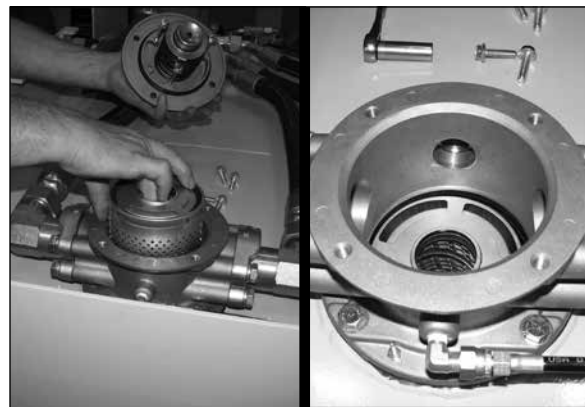

9. Replace filter head assembly onto housing and secure with fasteners removed in step 2.
10. Start up power pack and run until hydraulic system is warm, start boring head and jacking motors and check for leaks.
11. Stop motor and shutdown power pack. Replace other filter if needed.

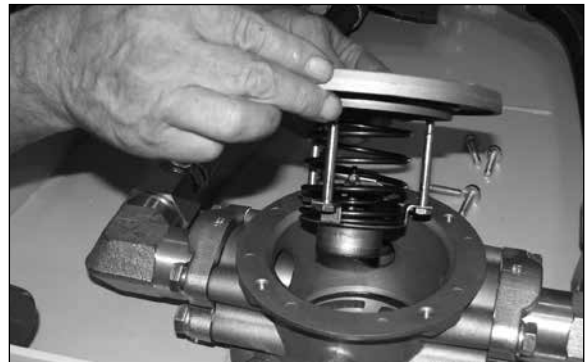

#### 42. INSPECT WINCH CABLE

Inspect winch cable (A) for kinks, fraying, broken strands or other damage. Replace cable if damaged prior to use.

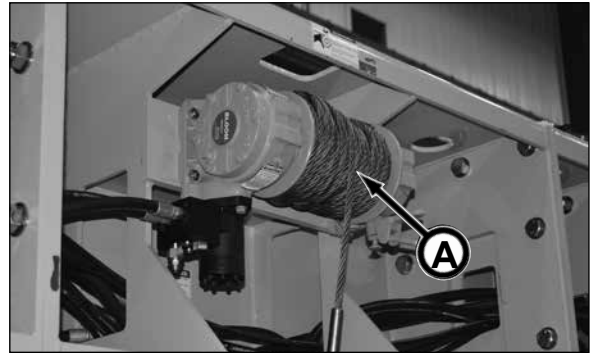

## WEEKLY OR EVERY 50 HOURS OF OPERATION

### 43. CHECK DRIVE MOTOR GEARBOX OIL CONDITION & OIL LEVEL

Check the drive motor gearbox oil condition:

1. Clean area around the ports.
2. Drain a measured sampling of the gearbox oil.
3. Inspect the drained oil for contaminants.
4. Repeat for the other three drive motor gearboxes.

- If water is visible in the oil, seals are damaged and must be replaced
- With any contamination, the gear box must be completely drained and refilled with fresh, clean Mobil SHC™ 630 Synthetic Bearing and Gear oil.

Check the drive motor gearbox oil level:

1. Position the gearbox with the fill port (A) in the 12 o'clock position and the check port in the 9 o'clock or 3 o'clock position.
2. Remove the check plug (B). If the oil is not visible at the check port level, add fresh, clean Mobil SHC™ 630 Synthetic Bearing and Gear oil in the fill port until the oil is level with the check port.
3. Repeat for the three other drive motor gearboxes.

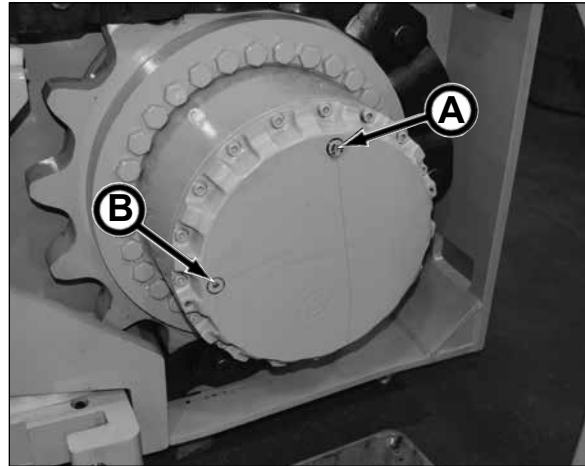

### 44. CHECK ELECTRIC MOTORS

#### NOTICE

Refer to the electric motor manufacturer for additional electric motor maintenance information.

Inspect the ventilation openings of the 166 HP and 5 HP motors so they are clear to allow the free passage of air. Also, be sure the drain holes are open.

Use compressed air (maximum 50 psi) to clear openings.

Grease and oil can be removed from the motors with a petroleum solvent.



166 HP Electric Drive Motor



5 HP Electric Cooling /Charge Motor

#### 45. LUBRICATE PIPE CLAMP ASSEMBLY

Lubricate pipe clamp assembly (E) (3 places) with Mobilgrease® XHP222 or equivalent until grease is forced out.

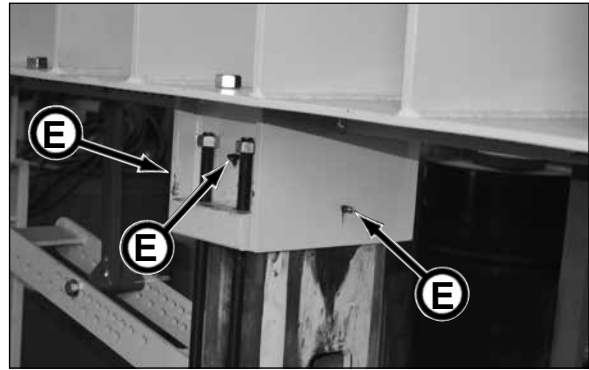

## EVERY 100 HOURS OF OPERATION

### 46. DRAIN & FILL WINCH GEAR CASE OIL

**NOTICE** Refer to the winch manufacturer for additional information.

Drain and fill winch gear case oil as follows:

1. Clean area around the fill (A) and drain (B) port plugs.
2. Remove plugs and drain oil from gear case into a properly sized catch container.
3. Inspect the drained oil for contaminants. If excessive metal particles are found, the winch will require maintenance.
4. Replace drain plug (B).
5. Add approximately 2 pt. ((946 ml) of fresh, clean Bloom® Ultra-Lube no. 601 trans-worm gear oil or 80W90 superior multi-purpose gear oil through fill port (A).
6. Replace both fill plug.

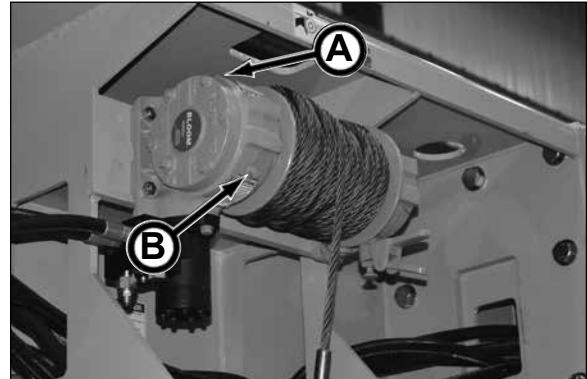

## FIRST 150 HOURS OF OPERATION, THEN EVERY 1000 HOURS

### 47. DRAIN & FILL DRIVE MOTOR GEARBOX

Drain and fill each drive motor gearbox as follows:

1. Clean area around the port plugs.
2. Position the gearbox with one port at the 6 o'clock position with the other port at the 3 o'clock or 9 o'clock position.
3. Remove plugs and drain oil from gearbox into a properly sized catch container.
4. Inspect the drained oil for contaminants. If excessive metal particles are found, the gear box will require maintenance.
5. Carefully move the gearbox 1/4 turn so the fill port (A) is at the 12 o'clock position and the check port (B) is at the 3 o'clock or 9 o'clock position.
6. Add approximately 3 gal. (11 L) of fresh, clean Mobil SHC™ 630 or ISO-VG-220 oil through fill port.

The oil level must be at the check plug level.

8. Replace both fill and check plugs.
9. Repeat steps 1 through 8 for the other three drive motor gearboxes.

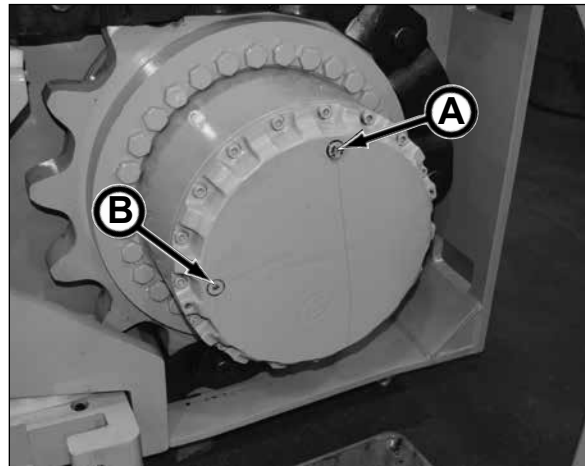

## MONTHLY OR EVERY 250 HOURS OF OPERATION

### 48. PERFORM HYDRAULIC OIL ANALYSIS

Test the quality of the hydraulic reservoir oil. Perform an oil analysis by sending an oil sample to a qualified testing facility.

If the test reveals higher contamination levels than allowed by your oil manufacturer, or if your oil is milky or discolored, drain and replace the hydraulic reservoir oil. If draining and replacing the hydraulic oil reservoir is required, all hydraulic filters should also be replaced.



## COMPLETION OF EACH DRIVE

### 49. PRESSURE WASH SLIPLINING FRAME

**⚠WARNING** Using a pressure washer can generate enough fluid pressure and velocity to penetrate skin resulting in serious personal injury.

Contact medical help immediately if fluid is injected into your skin. A serious infection or reaction can emerge without proper medical treatment.

NEVER point the wand towards a person or animal.

Be sure to release pressure after use and before performing maintenance to prevent accidental fluid injection.

Wear safety glasses and gloves, and depending on the wand use, a particle mask may be necessary.

After completion of the drive, pressure wash the sliplining frame to help prevent job site corrosive materials or chemicals from damaging the sliplining frame and components.

Thoroughly pressure wash the following areas of the sliplining frame. DO NOT apply direct water pressure on any electrical components or connections. Doing so will damage the electrical components or connections.

- overall frame
- center sections
- spacer sections
- frame extensions (if used)
- thrust ring
- chains
- drawbar
- pipe clamp assembly
- elevator columns
- inside frame end sections (for easy access remove motor panels; be careful to not pressure wash the motor speed sensors)

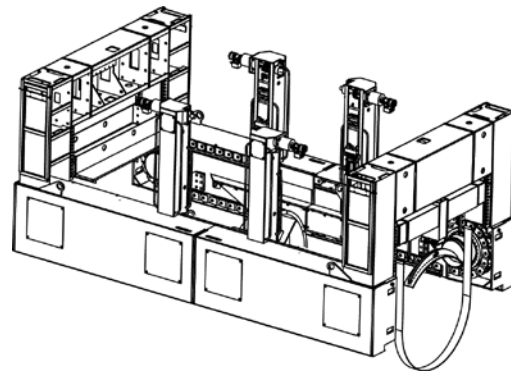

### 50. INSPECT SLIPLINING FRAME

Perform a visual inspection of the sliplining frame for cracks, wear or other damage. Repair or replace BEFORE operation.

Check for oil leaks and debris buildup. Make repairs as needed and remove debris.

Check for loose, damaged or missing parts. Repair or replace as necessary. Replace any defective parts.

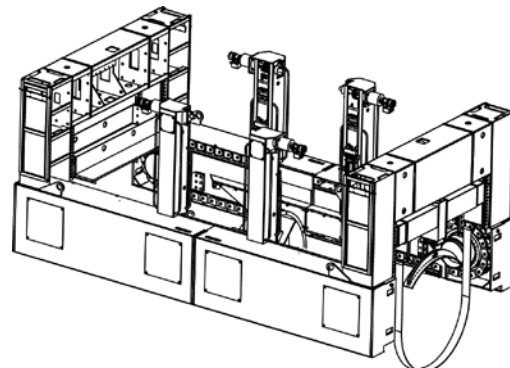

### 51. CHECK DRIVE MOTOR GEARBOX OIL CONDITION & OIL LEVEL

Check the drive motor gearbox oil condition:

1. Clean area around the ports.
2. Drain a measured sampling of the gearbox oil.
3. Inspect the drained oil for contaminants.
4. Repeat for the other three drive motor gearboxes.

- If water is visible in the oil, seals are damaged and must be replaced

- With any contamination, the gear box must be completely drained and refilled with fresh, clean Mobil SHC™ 630 Synthetic Bearing and Gear oil.

Check the drive motor gearbox oil level:

1. Position the gearbox with the fill port (A) in the 12 o'clock position and the check port in the 9 o'clock or 3 o'clock position.
2. Remove the check plug (B). If the oil is not visible at the check port level, add fresh, clean Mobil SHC™ 630 Synthetic Bearing and Gear oil in the fill port until the oil is level with the check port.
3. Repeat for the three other drive motor gearboxes.

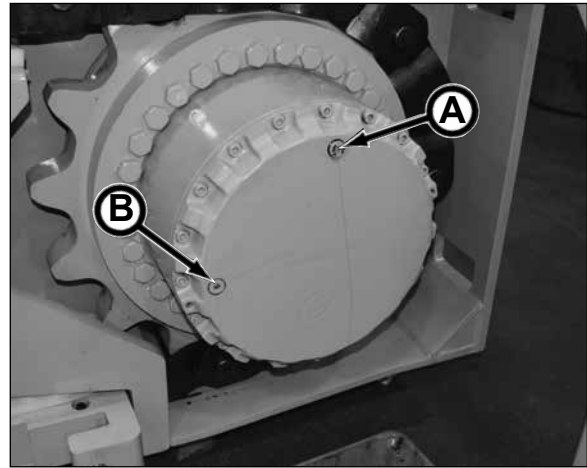

### 52. CHECK ELEVATOR MOTOR GEARBOX OIL LEVEL

Remove the check plug (C). If the oil is not visible at the check port level, add fresh, clean Mobil SHC™ 630 Synthetic Bearing and Gear oil in the fill port (D) until the oil is level with the check port.

Repeat for the other three elevator motor gearboxes.

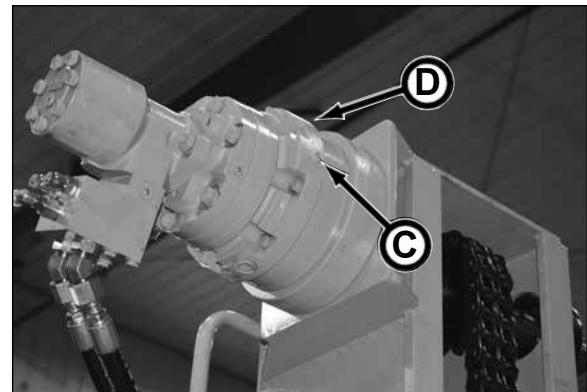

### 53. INSPECT LIFTING EYES

Inspect ALL lifting eyes (C) for wear or damage. Worn or damaged lifting eyes MUST be replaced before lifting.

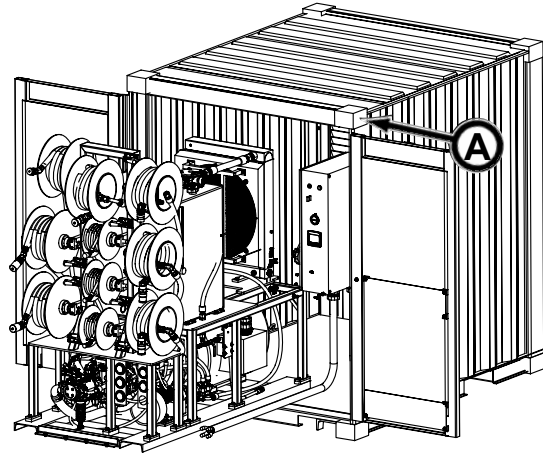
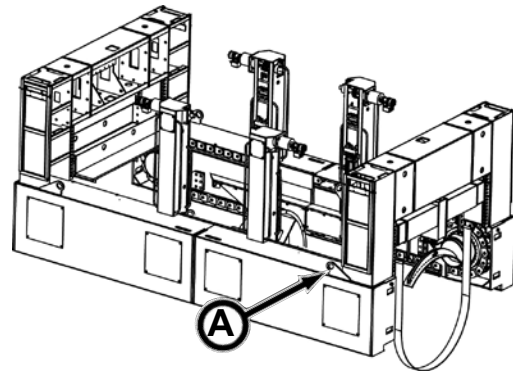

### 54. CLEAN MAIN DRIVE CHAIN

Using a power washer, clean main drive chain (B).

If using sliplining frame shortly:

- Apply SAE 90 (Schedule 220) gear oil or equivalent to chain.

If sliplining frame will be placed in storage:

- Spray LPS® 3 Premier Rust Inhibitor on chain.

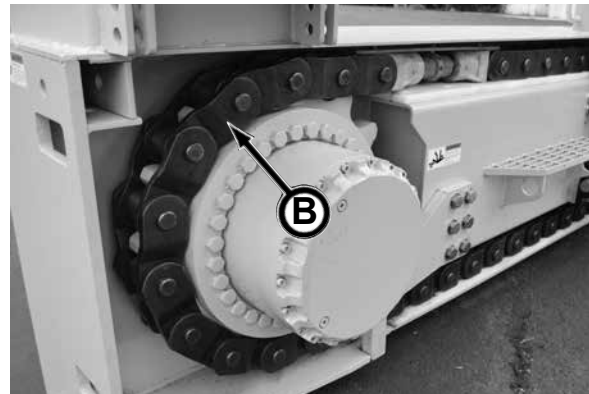

### 55. CLEAN MAIN DRIVE CHAIN

Using a power washer, clean elevator chain (C).

If using sliplining frame shortly:

- Apply SAE 90 (Schedule 220) gear oil or equivalent to chain.

If sliplining frame will be placed in storage:

- Spray LPS® 3 Premier Rust Inhibitor on chain.

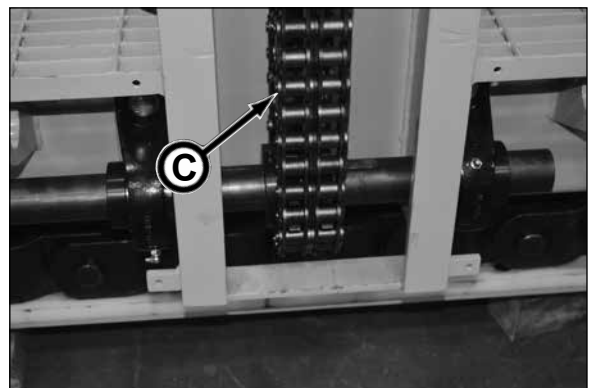

## 56. INSPECT HYDRAULIC HOSES & POWER CABLES

**⚠ DANGER** If high voltage cables or cable connections are frayed, worn or damaged, contact with cables/connections will result in electrical shock causing severe injury or death.

With power in LOCK OUT, TAG OUT, check electrical power cables and connections for fraying, wear or damage. If damaged, the cables must be replaced BEFORE operation.

Inspect ALL hydraulic hoses for cracks, wear or other damage. Repair or replace BEFORE operation.

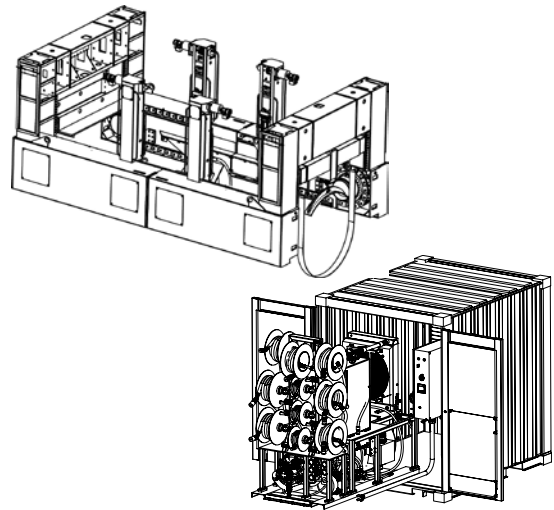

## 57. INSPECT POWER PACK FRAME

Perform a visual inspection of the power pack. Inspect structures, mountings and lubricant levels.

Immediately report any structural problems to your Akkerman aftermarket support representative.

Check for oil leaks and debris buildup. Make repairs as needed and remove debris.

Check for loose, damaged, or missing parts. Repair or replace as necessary. Replace any defective parts.

Tighten hardware as needed. Do not overtighten hardware.

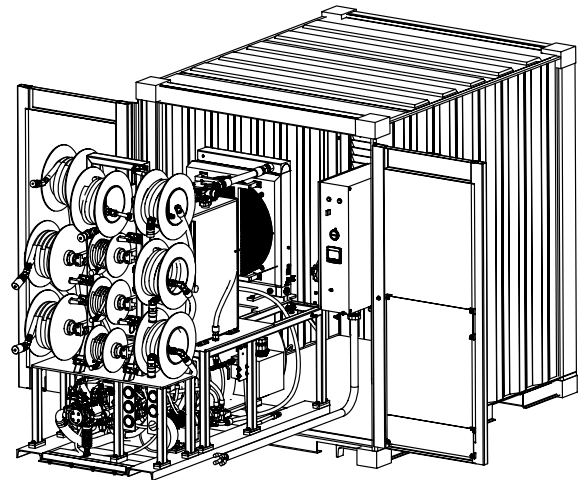

## 58. DRAIN WATER FROM HYDRAULIC RESERVOIR

Remove water contamination from the hydraulic reservoir by draining water from the reservoir at the completion of each drive.

1. With power pack on level ground, allow oil in hydraulic reservoir to settle overnight.
2. Remove plug (A) and install a 1/2" NPT hose to tank valve fitting.
3. Route hose into a catch pan.
4. Slightly open tank drain ball valve (B) and drain until there is no water in oil.
5. Once water is removed from tank, close tank drain ball valve, remove hose (if used) and reinstall plug.

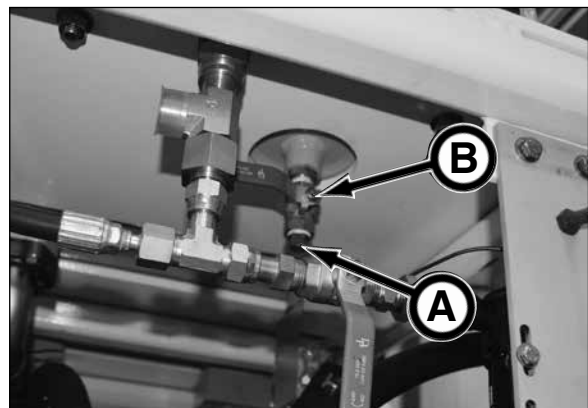

### 59. CONNECT FRAME CASE DRAIN HOSE TO THERMAL RELIEF TANK

When sliplining frame hydraulic hoses are not connected to the power pack hydraulic hoses or when frame is in storage, the sliplining frame case drain hose (A) MUST be connected to the case drain thermal relief tank (B) on the frame. This will prevent oil expansion from causing damage to the shaft seals in the hydrostatic motors, resulting in oil leaking on the final drives. The relief tank will handle the expansion and contraction of the oil in the case drain circuit while preventing air from entering the system.

1. Disconnect the case drain hoses from the sliplining frame to the power pack.
2. Wind up the power pack case drain hose onto hose reel for storage.
3. Connect the frame case drain hose quick disconnect (A) to the case drain thermal relief tank hose quick disconnect (C).

**NOTICE** If oil is leaking out of the case drain thermal relief tank breather (D), the tank must be drained. If draining is necessary, one gallon (3.8 L) of oil must be left in the tank. The relief tank oil capacity is approximately 5 gal. (19 L).

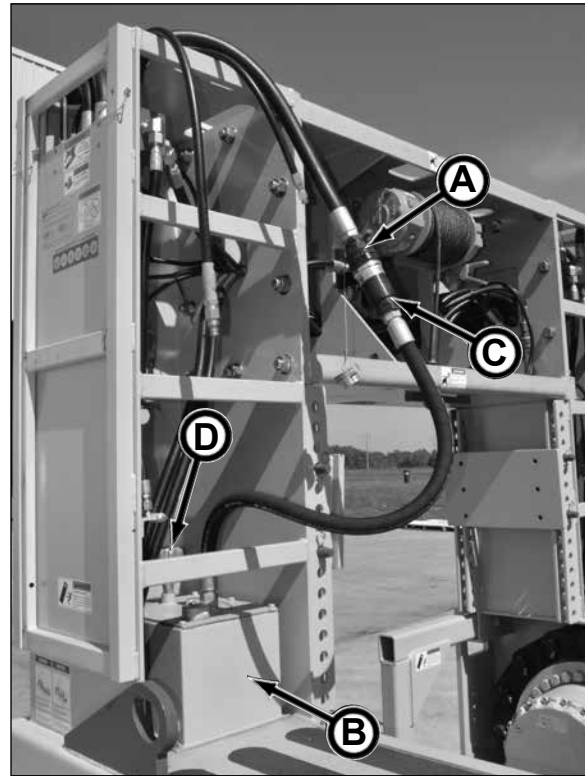

## EVERY 500 HOURS OF OPERATION

### 60. REPLACE LOAD SENSE FILTER

The load sense filter (A) must be replaced at:

- 500 hours or yearly, which ever occurs first
- a major component fails
- any signs of water contamination
- hydraulic fluid sample indicates large particle contamination
- controls are sluggish

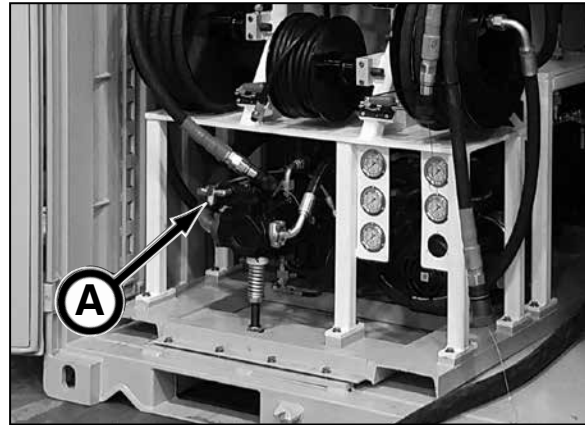

**NOTICE** Installing a load sense filter incorrectly, WILL cause pump malfunction.

1. Remove cap, spring, and filter from filter head.
2. Insert new filter (B) with nylon ring end (C) into filter head (D).
3. Place spring (E) into cap (F).
4. Install cap onto filter head. Tighten to 10 ft-lb (13.6 N·m) torque.

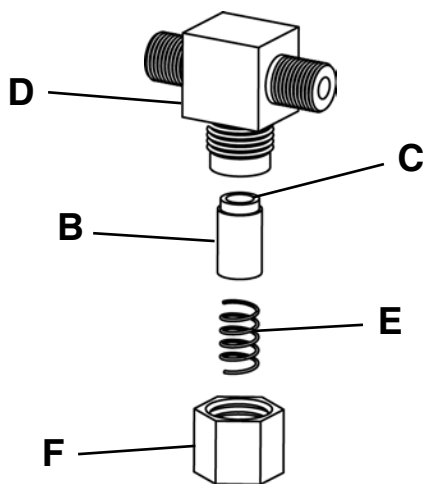
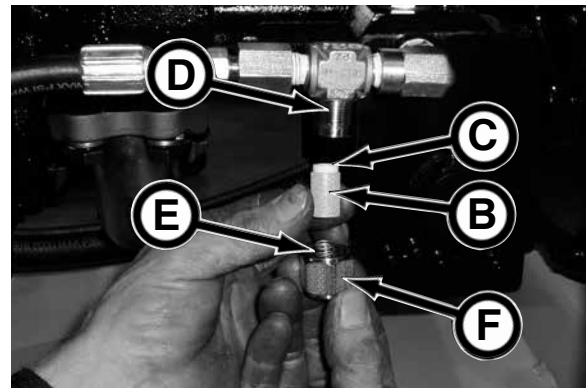

*Load Sense Filter Installation*



## EVERY 1000 HOURS OF OPERATION

### 61. DRAIN & FILL DRIVE MOTOR GEARBOX

Drain and fill each drive motor gearbox as follows:

1. Clean area around the port plugs.
2. Position the gearbox with one port at the 6 o'clock position with the other port at the 3 o'clock or 9 o'clock position.
3. Remove plugs and drain oil from gearbox into a properly sized catch container.
4. Inspect the drained oil for contaminants. If excessive metal particles are found, the gear box will require maintenance.
5. Carefully move the gearbox 1/4 turn so the fill port (A) is at the 12 o'clock position and the check port (B) is at the 3 o'clock or 9 o'clock position.
6. Add approximately 3 gal. (11 L) of fresh, clean Mobil SHC™ 630 or ISO-VG-220 oil through fill port.

The oil level must be at the check plug level.

8. Replace both fill and check plugs.
9. Repeat steps 1 through 8 for the other three drive motor gearboxes.

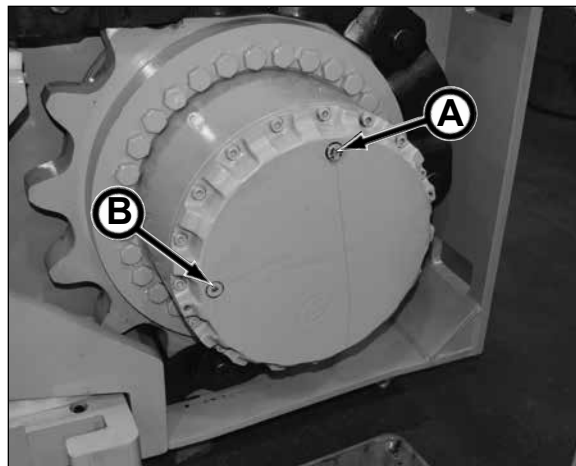

### 62. DRAIN & FILL ELEVATOR MOTOR GEARBOX

Drain and fill each elevator motor gearbox as follows:

1. Clean area around fill plug (C), check plug (D) and drain plug (E).
2. Remove check plug (D).
3. Remove drain plug (E) and drain oil into a properly sized catch container.
4. Replace drain plug.
5. Inspect the drained oil for contaminants. If excessive metal particles are found, the gear box will require maintenance.
6. Remove fill plug. Add approximately 23 oz. (89 ml) of fresh, clean Mobil SHC™ 630 Synthetic Bearing and Gear oil in the fill port (C).

The oil level must be level with the check port.

7. Replace both fill and check plugs.
8. Repeat steps 1 through 7 for the other three elevator motor gearboxes.

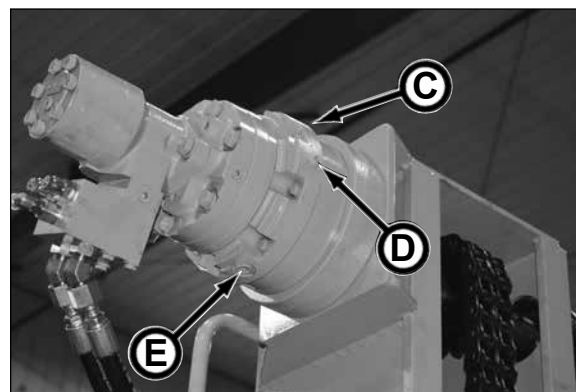

### 63. DRAIN & FILL HYDRAULIC RESERVOIR

1. Drain oil into an appropriate sized catch pan as follows:

Remove plug (A) from ball valve (B) and install a 1/2 NPT hose to fitting. Open ball valve and drain oil. Close ball valve, remove hose and reinstall plug.

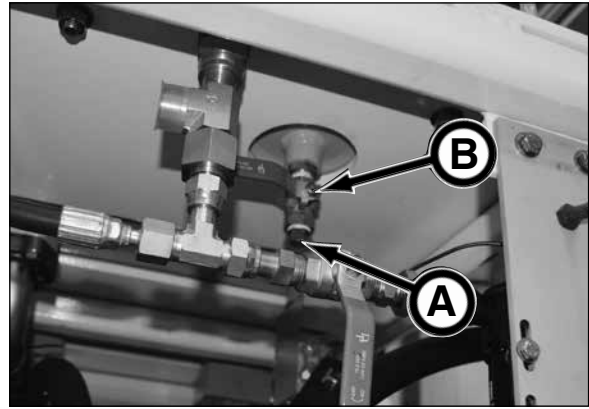

2. Remove hydraulic fill hose from storage location. Remove cap from hose.



3. Place hose into a clean hydraulic oil container.

**NOTICE** Refer to Lubricants section for recommended hydraulic oil.



4. Open hydraulic fill shut off valve by moving handle up to the 3 o'clock position.



(continued on next page)

**IMPORTANT: BEFORE** filling hydraulic reservoir, the breather/fitting must be removed to allow for proper venting. Failure to do so will result in pump damage. Be sure to replace breather/fitting after filling reservoir.

5. Remove breather/fitting (A) from reservoir BEFORE filling reservoir to allow for proper venting during filling process.

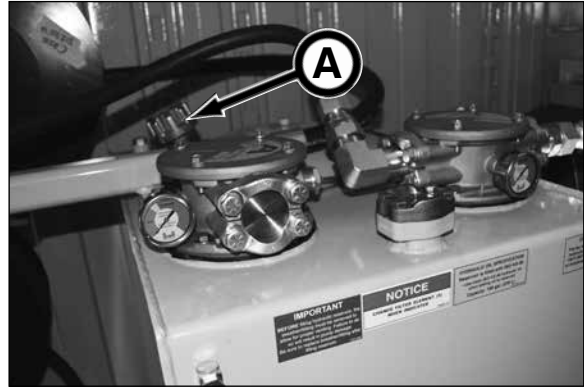

6. Flip Oil Transfer Pump switch in the power pack up to the ON position to pump hydraulic oil into the hydraulic reservoir.



7. Fill until oil reaches the high mark on gauge (B).

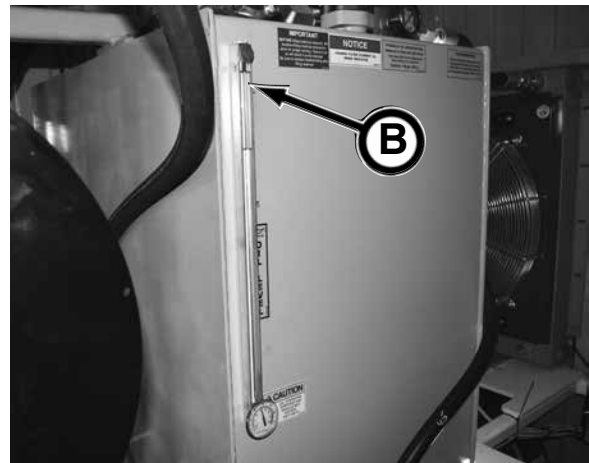

*(Continued on next page)*

8. Flip Oil Transfer Pump switch down to the OFF position.



9. Replace breather/fitting (A) on reservoir.

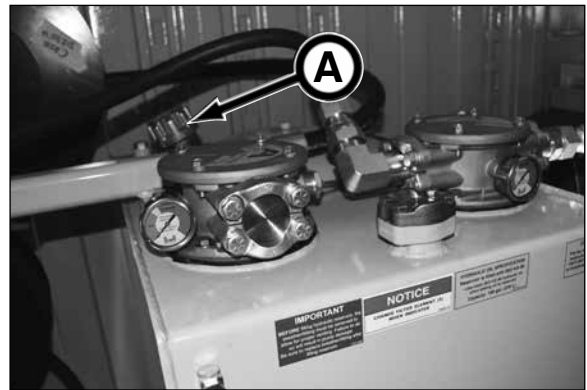

10. Close hydraulic fill shut off valve by moving handle down to the 6 o'clock position.
11. Replace cap on fill hose and place hose in storage location.

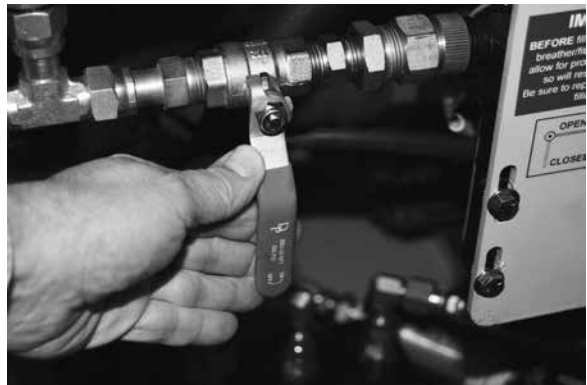

#### 64. CHECK DRIVE SPROCKET BOLT TIGHTNESS

Using a calibrated torque wrench, check that the drive sprocket bolts (A) are tightened to 630 ft-lb (854 N·m) (lubed) torque. There are 128 bolts.

If a bolt will not tighten to the specified torque, replace with a new bolt. Also, replace the bolts on either side of the bolt that will not tighten to the proper torque.

If a bolt is damaged, replace with new. In addition replace the bolts on either side of the damaged bolt.

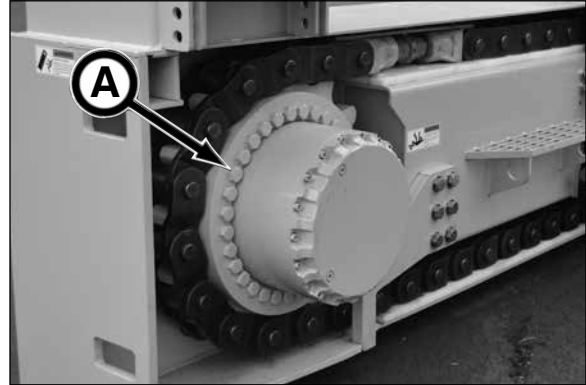

#### 65. CHECK FINAL DRIVE MOUNTING BOLT TIGHTNESS

1. Remove cover (B) to gain access to the final drive.
2. Using a calibrated torque wrench, check that the final drive mounting bolts (C) are tightened to 630 ft-lb (854 N·m) (lubed) torque. There are 128 bolts.

If a bolt will not tighten to the specified torque, replace with a new bolt. Also, replace the bolts on either side of the bolt that will not tighten to the proper torque.

If a bolt is damaged, replace with new. In addition replace the bolts on either side of the damaged bolt.

3. Replace cover.

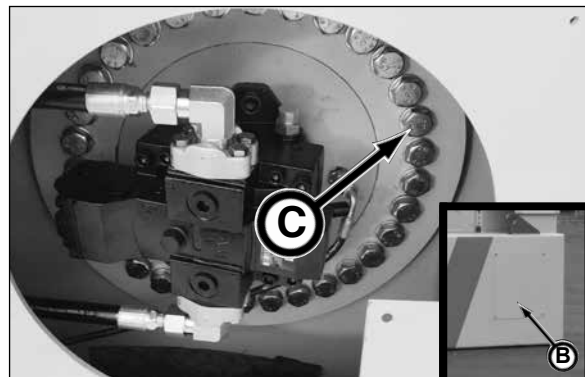

#### 66. CHECK DRIVE MOTOR MOUNTING BOLT TIGHTNESS

1. Remove cover (D) to gain access to the final drive.
2. Using a calibrated torque wrench, check that the drive motor mounting bolts (E) are tightened to 250 ft-lb (339 N·m) (lubed) torque. There are two bolts per drive motor.

If a bolt will not tighten to the specified torque, replace with a new bolt.

If a bolt is damaged, replace with a new bolt.

3. Replace cover.

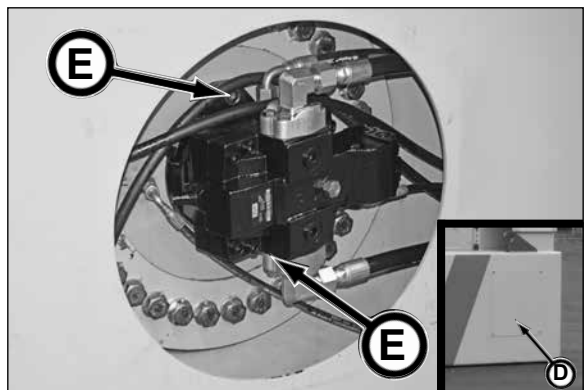

## 67. CHECK DRAWBAR STOP MOUNTING BOLT TIGHTNESS

**NOTICE** If a hard impact on a drawbar stop (A) occurs, check the mounting bolt tightness.

Using a calibrated torque wrench, check that the drawbar stop mounting bolts (B) are tightened to 680 ft-lb (lubed) (922 N·m) torque. There are six bolts per drawbar stop.

If a bolt will not tighten to the specified torque, replace with ALL new bolts on the mount.

If a bolt is damaged, replace with ALL new bolts on the mount.

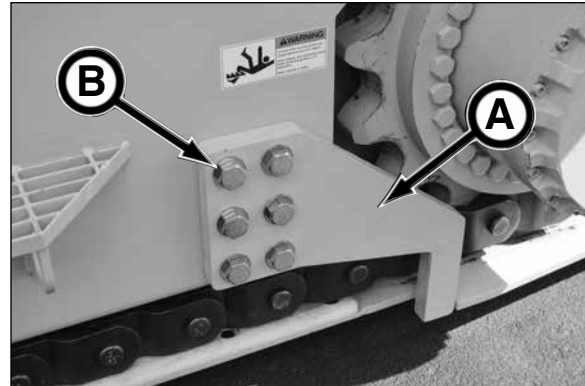

## ANNUALLY

### 68. LUBRICATE MOTOR BEARINGS

**NOTICE** Refer to the electric motor manufacturer for additional electric motor maintenance information.

Lubricate the electric motor bearings with two shots of Mobil Polyrex® EM grease or equivalent (refer to Grease Type below). There are two lubrication fittings on each electric motor.

When adding lubricant, keep dirt out of the lubrication area. Wipe the fitting completely clean and use clean greasing equipment.

**GREASE TYPE (unless nameplate states otherwise:**

***Nameplate Ambient Temperature between -22°F (-30°C) to 150°F (65°C) inclusive:***

Recommended grease for standard service conditions is Mobil Polyrex® EM. Equivalent and compatible greases include: Texaco Polystar RB, Rykon Premium #2, Pennzoil Pen 2 Lube, Chevron SRI & Mobil SHC 100.

***Nameplate Ambient Temperature below -22°F (-30°C):*** Special low temperature grease is recommended such as Aeroshell 7 or Beacon 325 for ball bearings and Mobil SHC 100 for roller bearings.



166 HP Electric Motor

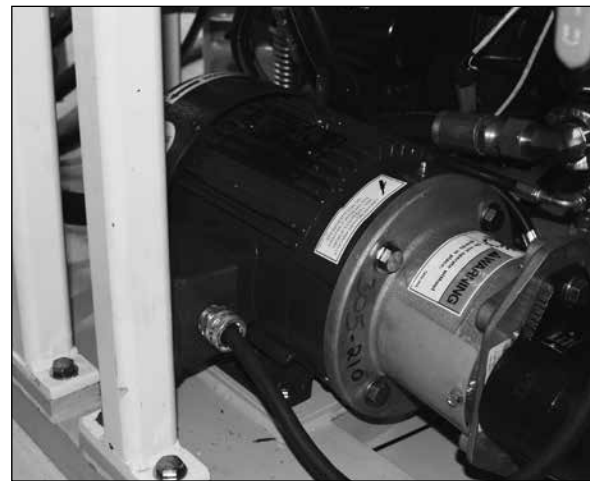

5 HP Electric Motor

## **NOTES**

# Storage

---

## PREPARING FOR STORAGE

### NOTICE

Follow the lubrication and maintenance requirements in the Periodic Maintenance section.

1. Repair worn or damaged parts.
2. Wash all equipment thoroughly.
3. Lubricate all equipment grease points . Grease threads on bolts used for adjustments.
4. Spray LPS® 3 Premier Rust Inhibitor on drive chain and elevator chain.
5. Wind all hydraulic hoses onto hose reels in power pack. Connect sliplining frame case drain hose to frame case drain thermal relief tank to prevent damage to the shaft seals in the hydrostatic motors.
6. Retract all hydraulic cylinders if possible. If not, coat exposed cylinder rods with a corrosion preventive.
7. Repaint equipment where necessary.
8. Drain hydraulic oil, flush oil reservoir, change hydraulic filters, and refill hydraulic reservoir. Check for leaks.
9. Wipe up lube spills. Dispose of rags and trash properly. Store oily rags and other flammable material in protective containers.
10. If possible, store equipment under cover and out of the weather in a ventilated area.
11. Do not smoke in areas where flammable materials are stored.
12. Store fuels and lubricants in properly marked containers.

---

## REMOVING FROM STORAGE

### NOTICE

Follow the lubrication and maintenance requirements in the Periodic Maintenance section.

1. Clean equipment thoroughly.
2. Check to make sure all decals including safety decals are clean and readable.
3. Check condition of wires and cables. Repair or replace as necessary.
4. Remove the cylinder corrosion preventive from the cylinder rods if it is not compatible with hydraulic oil or seal materials.
5. Lubricate the drive chain and elevator chain with SAE 90 (Schedule 220) gear oil or equivalent.
6. Check for leaks. Repair or replace as necessary.
7. Check hydraulic oil level in reservoir. If fluid is low, check for leaks and add oil as required. Refer to Lubricants section.
8. Perform a oil analysis on the oil in the hydraulic reservoir. Replace the hydraulic oil and filters if the test reveals contamination.
9. Check the return filter indicators. Replace filter(s) as needed.
10. Check condition of all hoses and connections. Tighten, repair or replace with new as needed.
11. Before operating, cycle hydraulic functions several times to purge air from the hydraulic system.
12. Review this Operator's Manual and any supporting equipment operation manuals.

## **NOTES**

# Troubleshooting

## SLIPLINING SYSTEM

Problem	Cause	Solution	
166 HP motor will not start.	Emergency stop button pushed IN.	Pull E-STOP button out.	
	Main disconnect switch is OFF	Turn disconnect ON.	
	Pump switch On before pendant is connected to receiver.	Toggle Pump switch off and on.	
	Pendant is in sleep mode.	Toggle Start switch off and on.	
	Generator or power supply faulty.	Repair or replace.	
	Faulty Start/Stop switch.	Replace switch.	
	Low oil level.	Fill reservoir with oil.	
	Faulty low oil level switch or relay.	Replace switch or relay.	
	Oil has reached high temp shutdown setting.	Check cooling water supply and allow time for circuit to reset.	
	Faulty high temp switch or relay.	Replace switch or relay.	
5 HP pump not operating	Reset 5 HP overload relay and check fuses.		
	No power pack motor will start.	Emergency stop button is depressed.	Pull out all E-Stop buttons.
		Power source is Off.	Turn on power source.
		Power cables from power source not connected to the power pack.	Secure power cables from power source to power pack.
		Improper phase power.	Contact electrician to correct phase.
		Main disconnect not turned ON.	Turn ON main disconnect.
		Generator or power supply faulty.	Repair or replace.
		Pendant not connected.	Connect pendant.
		Faulty communication extension cable.	Test without extension cable, repair cable.
		Low oil level.	Add oil.
Oil has reached high temp shutdown setting.		Check cooling water supply and allow time for circuit to reset.	
Drawbar position not staying aligned.	Faulty low oil level switch, cable or relay.	Replace switch, cable or relay.	
	Faulty E-stop cable, switch or relay.	Replace switch, cable or relay.	
	Drawbar is not being fully extended to full travel stop positions.	Fully extend drawbar to stops.	
	Travel limits not set properly.	Reset travel limits.	
	Dirty charge filters.	Replace charge filters.	

## Troubleshooting

Problem	Cause	Solution
Drawbar does not move or only one side moves.	Quick disconnects not connected properly.	Connect quick disconnects.
	Speed sensor fault.	Repair or replace sensor(s).
Slow drive travel response.	Dirty charge filters.	Replace charge filters.
Brake not working.	No hydraulic pressure.	Check hydraulic connections.
	No signal to valve.	Check wire harness connection.
	Faulty solenoid.	Inspect and repair solenoid.
High speed shift is not working.	No hydraulic pressure.	Check hydraulic connections.
	No signal to valve.	Check wire harness connection.
	Faulty solenoid.	Inspect and repair solenoid.
5 section valve functions are not working.	No communication to receiver.	Connect communication cable to receiver.
	No hydraulic pressure.	Check hydraulic connections.
	No power to receiver.	Connect power cable to receiver.
	Faulty receiver.	Inspect and repair receiver.
	No signal to solenoid.	Check wire harness connection.
	Faulty solenoid.	Inspect and repair solenoid.
Elevator columns do not work.	Dirty in-line load sense filter.	Replace in-line load sense filter.
Elevator columns are slow to respond.	Quick disconnects not connected properly.	Connect quick disconnects.
Temperature gauge exceeds 150 degrees.	Excessive hydraulic circuit pressure to machine.	Replace filters.
	Hydraulic circuit disconnected causing a safety relief to be activated.	Connect hoses.
	Excessive ambient temperature.	Provide fresh air.
	Oil cooler fins/tubes plugged.	Clean oil cooler.
Power pack motors start but no oil pressure available.	<b>NOTICE</b> DO NOT operate for extended periods with this condition. Doing so will result in pump damage.	
	Low oil level.	Add hydraulic oil as needed.
	Control valve not turned ON.	Turn control valve ON.
	Faulty control valve switch.	Repair or replace switch.
	Worn or damaged hydraulic pump.	Repair or replace pump.

**NOTICE** If the troubleshooting solutions still do not resolve the issue, contact your Akkerman Aftermarket Support Representative.

# HYDRAULIC SCHEMATIC - SLIPLINING FRAME

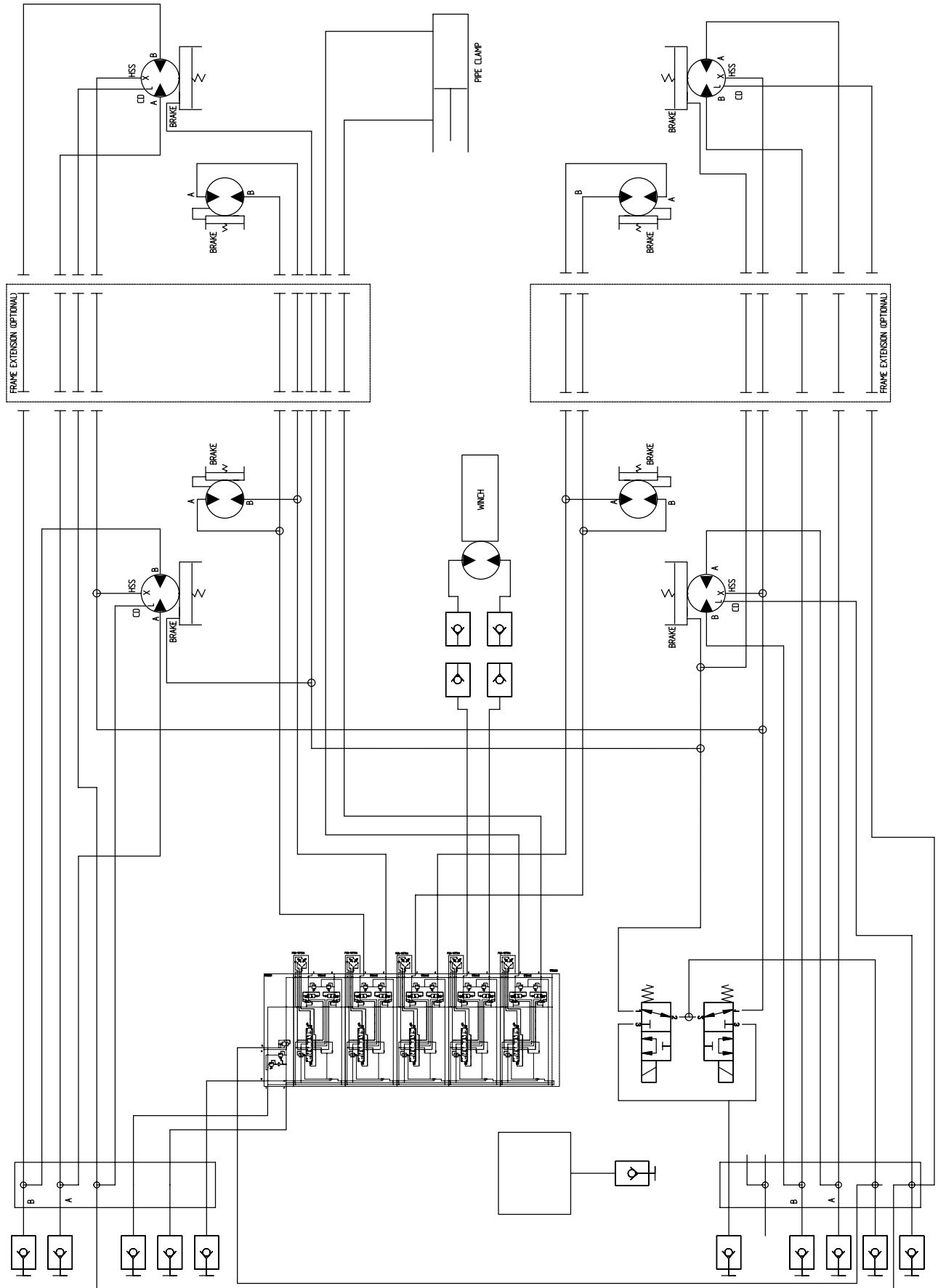

# HYDRAULIC SCHEMATIC - SLS POWER PACK

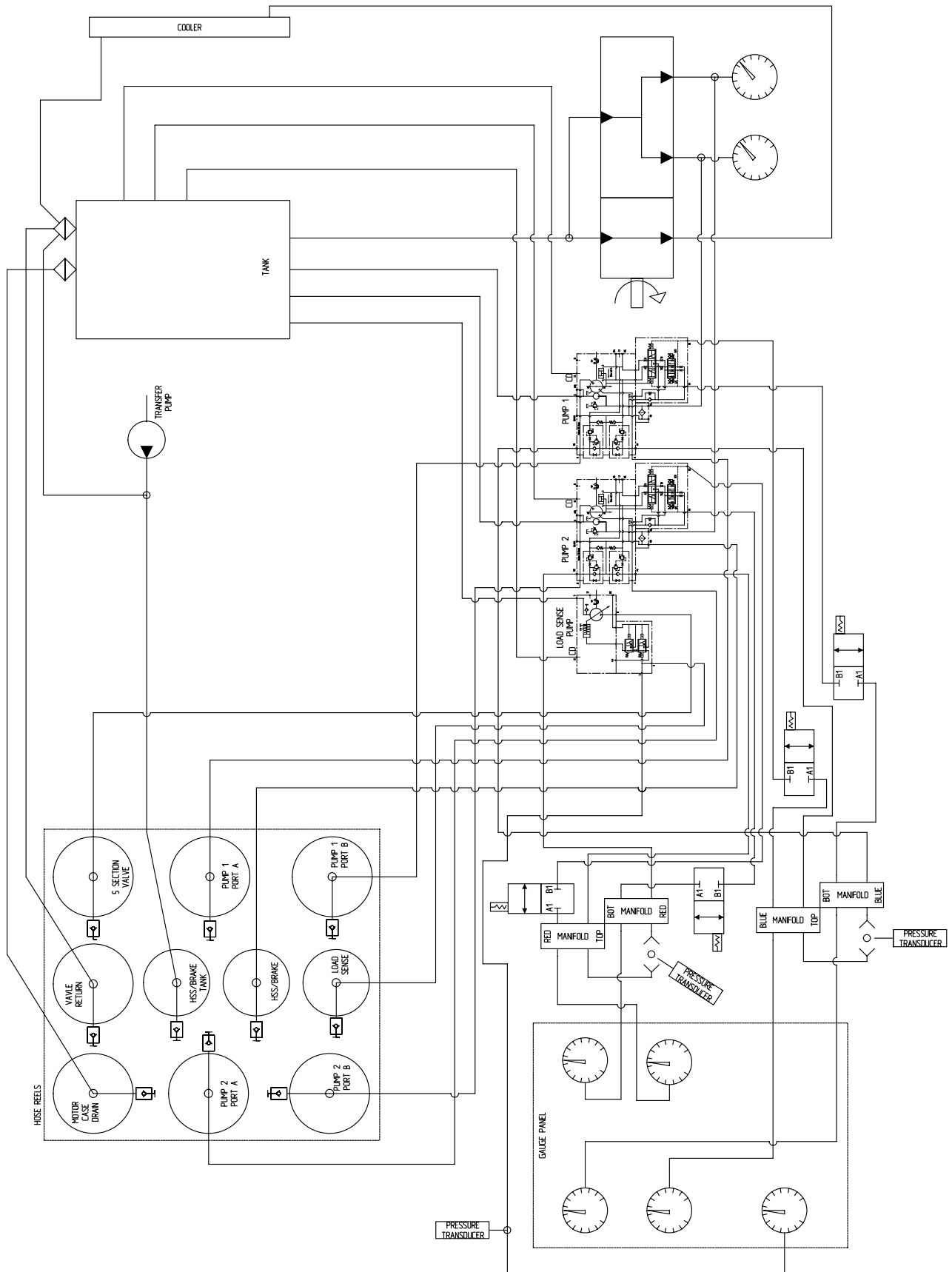

## **NOTES**

# ELECTRICAL SCHEMATIC - SLIPLINING FRAME SN F40700F-02 & AFTER) - PART 1 OF 2

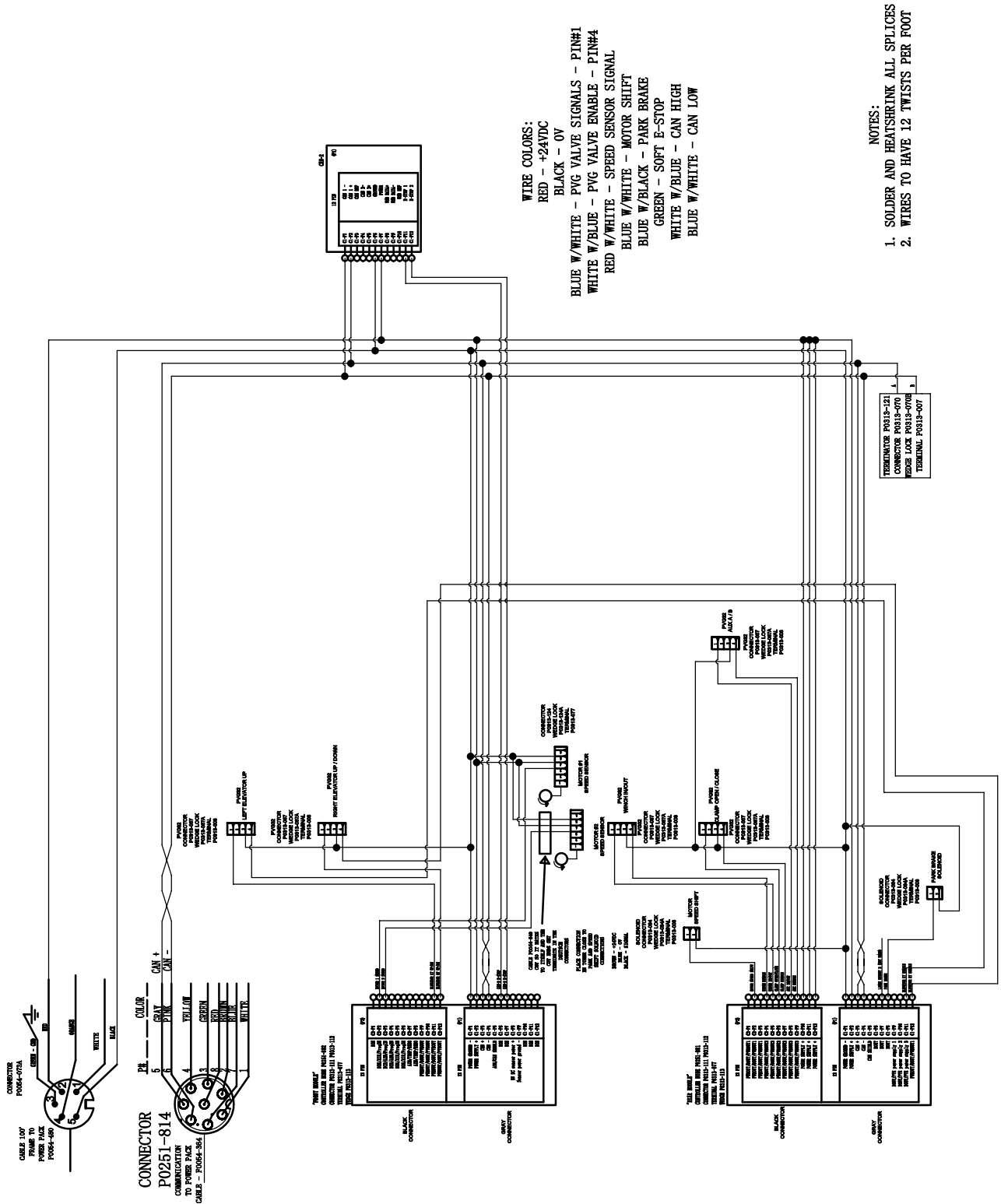

# ELECTRICAL SCHEMATIC - SLIPLINING FRAME SN F40700F-02 & AFTER) - PART 2 OF 2

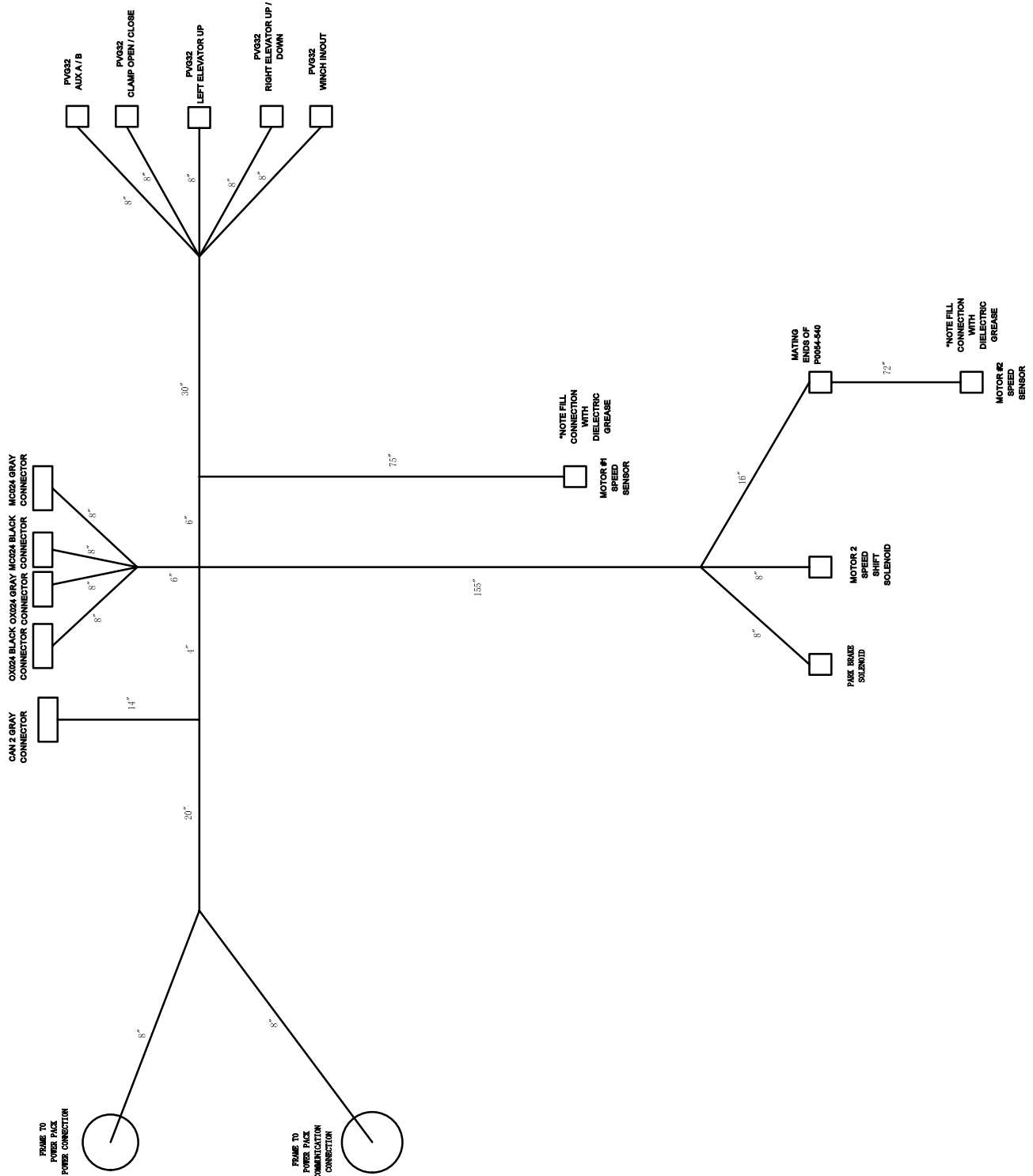



# Specifications

## SLIPLINING FRAME

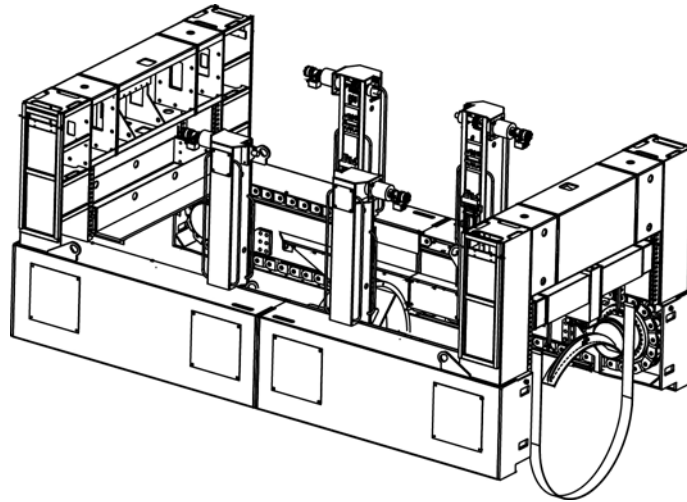

### Frame Dimensions

Length (Minimum) For 10 ft Pipe Joint.....	20 ft (6.1 m)
Length (Maximum) For 20 ft Pipe Joint.....	30 ft (9.1 m)
Height .....	8.5 ft (2.6 m)
Frame Width - Pipe OD Range	
8 ft (2.4 m).....	30 in. (0.76 m) OD
12 ft (3.7 m).....	78 in. (2 m) OD

**Weight** (11 ft Frame Width Without Extension)..... 35,000 lbs. (15,875 kg)

### Drive (Quad Drive)

Type .....	Four, 160 cc, Two Speed, Hydrostatic Drive Motors
Thrust Capacity .....	130 Tons (118 mt)
Speed	
High .....	0 - 22 ft/minute (0 - 6.7 m/minute)
Low .....	0 - 11 ft/minute (0 - 3.4 m/minute)
Draw Bar Travel .....	22.75 ft (6.9 m)

### Elevators (For Pipe Positioning)

Vertical Travel .....	71 in. (1.8 m)
Lifting Capacity	
Total .....	20,000 lbs. (9,027 kg)
Per Elevator .....	5,000 lbs. (2,268 kg)
Travel Rate .....	10 ft/minute (3 m/minute)

### Pipe Clamp

Axial Gripping Force .....	12,000 lbs. (5,442 kg)
Radial Force .....	10,000 lbs. (4,536 kg)

### Winch

Capacity .....	12,000 lbs. (5,442 kg)
Travel Rate .....	0 - 17 ft/minute (5 m/minute)

*Akkerman Inc. reserves the right to improve its product without notice or obligation.*

## SLIPLINING POWER PACK

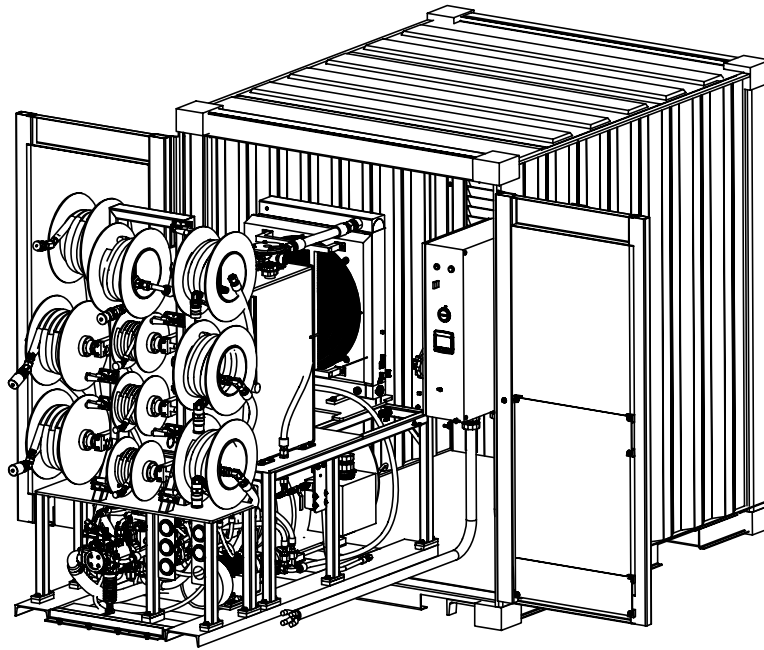

### Dimensions

Length ..... 8 ft (2.4 m)  
Height ..... 8 ft (2.4 m)  
Width ..... 6 ft 5 in. (2 m)

Weight ..... 11,000 lbs. (4,990 kg)

Hydraulic Oil Reservoir Capacity ..... 100 gal. (379 L)

### Pumps

Drive (Two Hydrostatic Pumps @ 100 cc) ..... 37 gpm @ 4,250 psi  
Load Sense ..... 21 gpm @ 2,000 psi

### Power - 400V, 50 Hz, 3 Phase

Electric Motor ..... 166 HP (124 kW)

### Generator Minimum Motor Starting kVA (skVA)

.... 640skVA with less than 35% instantaneous voltage dip and greater than 90% sustained voltage

*Akkerman Inc. reserves the right to improve its product without notice or obligation.*

## TORQUE CHART

Use these torque values as a guideline when tightening hardware unless otherwise specified in this manual.

Lubricated Coarse UNC Threads Grade 8 Fasteners			Lubricated Fine UNF Threads Grade 8 Fasteners		
Bolt Size	Torque		Bolt Size	Torque	
	ft. lbs.	(N·m)		ft. lbs.	(N·m)
1/4 - 20	10	(14)	1/4 - 28	11	(15)
5/16 - 18	20	(27)	5/16 - 24	22	(30)
3/8 - 16	35	(47)	3/8 - 24	39	(53)
7/16 - 14	56	(76)	7/16 - 20	62	(84)
1/2 - 13	85	(115)	1/2 - 20	96	(130)
9/16 - 12	123	(167)	9/16 - 18	137	(186)
5/8 - 11	170	(231)	5/8 - 18	192	(260)
3/4 - 10	301	(408)	3/4 - 16	336	(456)
7/8 - 9	450	(610)	7/8 - 14	500	(678)
1 - 8	680	(922)	1 - 12	740	(1003)
1-1/8 - 7	960	(1302)	1-1/8 - 12	1030	(1397)
1-1/4 - 7	1360	(1844)	1-1/4 - 12	1500	(2034)
1-1/2 - 6	2360	(3200)	1-1/2 - 12	2660	(3607)

## **NOTES**

# Identification Numbers

Model and serial numbers are required when ordering parts or requesting service information. Record your model and serial numbers below.

## SLIPLINING FRAME (A)

Model Number \_\_\_\_\_

Serial Number \_\_\_\_\_

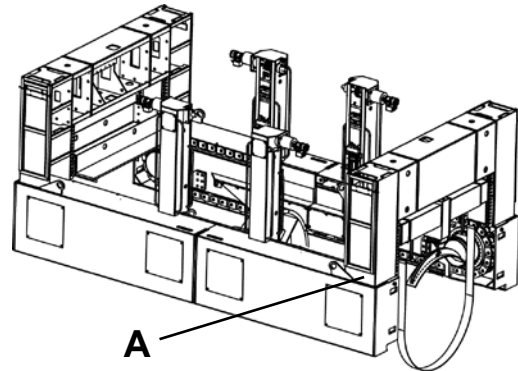

## SLS POWER PACK (B)

Model Number \_\_\_\_\_

Serial Number \_\_\_\_\_

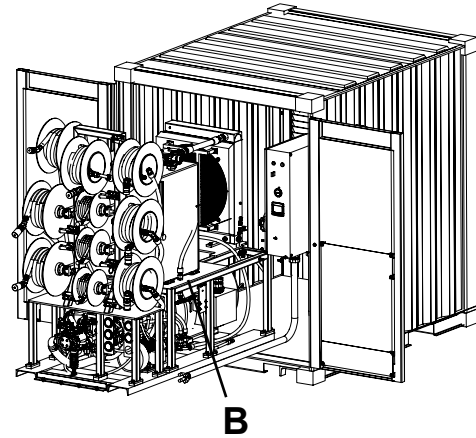

## **NOTES**

# Safety Data Sheets

The Federal Occupational, Safety, and Health Administration (OSHA) Standard 29 CFR 1910.1200, require that specific safety data sheets (SDS) be available to employees before operating this equipment. This may include information on substances contained in this equipment such as hydraulic fluid and gear lubricant.

Akkerman Inc. will provide, at no cost, SDS which apply to its product line. Simply contact your Akkerman Product Support representative for a copy.

To ensure a prompt response to your SDS request, include your return address (including zip or postal code) and the equipment's model numbers and serial numbers with your request.

## **NOTES**

# Warranty

Akkerman warrants that all equipment manufactured by it be free from defects due to workmanship or material when normally used and serviced for a period of 90 days from the date of shipment by Akkerman. Normal wear and tear to the equipment, including, but not limited to, wear on the cutter face tooling, hydraulic filters, augers, casings, slurry line and seals is not covered by this warranty. Akkerman does not warrant that the equipment meets the requirements of any particular safety code or rule governing equipment classification. If the Customer has questions about local safety codes, rules or ordinances, authorities local to the project should be consulted.

In order to be considered as a potential warranty claim, the component in question must be returned to Akkerman (freight prepaid) for factory inspection and analysis, and determination of warranty applicability. No warranty is provided for electronics or electrical components of any kind. The validity of all warranty claims are subject to the discretion and determination of the Akkerman Aftermarket Support Department. All such determinations are final.

*Warranty*

## **NOTES**

# Index

## A

Add graph ..... 6-37  
Adding new pipe ..... 6-24  
Adjustment, automatic fine ..... 6-16  
Analysis, soil ..... 6-4  
Angle support ..... 6-40  
Annually maintenance chart ..... 9-7  
Annually maintenance procedures ..... 9-47  
Api gl-1/gl-2 ..... 8-1  
Arrow buttons ..... 6-15  
Automatic fine adjustment ..... 6-16  
Automatic speed matching ..... 6-16  
Auxiliary control ..... 4-4, 6-19  
Auxiliary functions ..... 6-2  
Avoid pinch points ..... 1-4, 9-2

## B

Battery charger ..... 4-3, 9-21  
Battery level, pendant ..... 9-18, 9-21  
Bearings, electric motor ..... 8-1  
Bearings, motor ..... 9-47  
Before performing maintenance ..... 9-1  
Bloom® ultra-lube no. 601 oil ..... 8-3  
Bracing ..... 6-4  
Brake not working ..... 11-2  
Brake switch ..... 4-4  
Breather/fitting ..... 6-33, 9-25, 9-43  
Breather/fitting, tank ..... 6-32  
Breather, thermal relief tank ..... 9-39  
Brightness, setting display time, date & ..... 6-20

## C

Cabling ..... 6-27  
Cal button ..... 6-14  
Calculated tons of thrust ..... 4-5  
Calibration adjustment ..... 6-16  
Calibration, drive motor speed matching ..... 6-16  
Calibration window, pump ..... 6-16  
Calibration window, select ..... 6-16, 6-18  
Cal tab ..... 6-16, 6-18  
Canbus port ..... 4-3  
Capacity, oil ..... 8-1  
Capacity, thrusting ..... 6-2  
Case drain hose to thermal relief tank ..... 9-39  
Case drain quick disconnect ..... 6-8  
Cellular data network ..... 6-35  
Center seam frame section ..... 6-42  
Center section ..... 6-40  
Center section assembly ..... 6-41  
Chain drive systems ..... 6-2  
Chain sections ..... 6-42  
Chain tensioner ..... 6-42  
Chain tension rod link ..... 9-11, 9-23  
Change zone ..... 4-3, 6-23

## C (continued)

Changing frame length ..... 6-42  
Changing frame width ..... 6-40  
Changing pipe clamp assembly ..... 6-43  
Changing/removing drawbar ..... 6-43  
Changing thrust ring ..... 6-42  
Charger power light ..... 9-21  
Charging ..... 9-21  
Charging complete ..... 9-21  
Charging error ..... 9-21  
Check cable for continuity ..... 5-1  
Check hydraulics after system start-up ..... 6-23  
Checkout equipment prior to start-up ..... 6-10  
Clamp control ..... 6-19  
Clean and inspect equipment ..... 1-3  
Clear data log files ..... 6-38  
Clothing, protective ..... 1-1  
Code, softkey ..... 6-35  
Cold weather operation ..... 6-39  
Color coded hydraulic hose quick disconnects.. 6-8  
Columns, reformat ..... 6-38  
Comma separated value ..... 6-38  
Comm to frame ..... 6-5, 6-7, 6-44  
Completion of each drive  
    maintenance chart ..... 9-6  
    maintenance procedures ..... 9-35  
Concrete thrust block ..... 6-4  
Confirm window ..... 6-38  
Connect frame case drain hose to  
    thermal relief tank ..... 9-39  
Connecting power pack  
    electrical connections ..... 6-7  
    hydraulic hoses to sliplining frame ..... 6-8  
Contact with power cable ..... 1-4  
Contents ..... iii  
Control, auxiliary ..... 4-4  
Control, drawbar drive motor system ..... 4-4  
Control, elevator system ..... 4-4  
Controller ..... 6-17, 6-19  
Control operation check ..... 9-17, 9-20  
Control, pipe clamp ..... 4-4  
Control, pvg function speed ..... 6-18  
Control, setting drive pressure limit ..... 6-14  
Controls, five section valve ..... 4-2  
Controls & instruments ..... 4-1  
Controls, power pack ..... 4-2  
Controls, wireless remote pendant ..... 4-4  
Control, two speed ..... 4-4  
Control, winch ..... 4-4  
Cooling fan ..... 9-17  
Cooling fan clean & inspect ..... 9-17  
Crossover channel lead block ..... 9-11, 9-23  
Crushing hazard ..... 1-3

**D**

Daily or every 10 hours of operation	
maintenance chart .....	9-4
maintenance procedures .....	9-20
Daily shutdown .....	6-34
Data information .....	6-38
Data log files, clear .....	6-38
Data logging file .....	6-38
Data modem .....	6-35
Data parameter .....	6-37
Data, remote access .....	6-35
Data trend .....	6-37
Data, viewing input/output .....	6-20
Date & brightness, setting display time, .....	6-20
Decals .....	2-1
Decals inspect .....	9-19
Decals, sliplining frame .....	2-1
Decals, sliplining power pack .....	2-2
Default operation screen - lcd display .....	4-5
Deteriorating sewer lines .....	6-2
Diagnostic display .....	4-3, 6-20
Diagnostic display home screen .....	6-14
Diagnostic display module	
.....	6-16, 6-17, 6-18, 6-19, 6-20, 6-21
Display, diagnostic .....	6-20
Display, pendant lcd .....	6-21
Display time, date & brightness, setting .....	6-20
Documentation .....	6-35, 6-39
Download button .....	6-38
Download button, log file .....	6-38
Download icon .....	6-39
Drawbar .....	6-5, 6-22, 6-25, 6-42
Drawbar assembly .....	6-40, 6-41
Drawbar, changing/removing .....	6-43
Drawbar does not move or	
only one side moves .....	11-2
Drawbar drive motor system control .....	4-4
Drawbar lever .....	6-27, 6-29
Drawbar mounts .....	6-43
Drawbar not staying aligned .....	11-1
Drawbar pin .....	9-11, 9-23
Drawbar positioning switch .....	6-26
Drawbar stop .....	9-46
Drawbar tonnage .....	6-38
Drawbar vertical lead block .....	9-11, 9-23
Drive chain & elevator chain lubricant .....	8-3
Drive motor gearbox .....	9-33, 9-41
Drive motor gearbox oil .....	9-30
Drive motor gearbox oil condition .....	9-9, 9-36
Drive motor speed matching .....	6-16
Drive movement operation .....	6-17
Drive operation .....	6-17
Drive pressure adjust password .....	6-14
Drive pressure limit control, setting .....	6-14
Drive pressure limit screen .....	6-14
Drive pump pressures .....	4-2
Dual drive .....	6-2

**E**

Electrical connections .....	1-3
Electrical connections, connecting power pack ..	6-7
Electrical schematic -	
sliplining frame .....	11-6
sls power pack .....	11-8
Electric motor bearings .....	8-1
Electric motor grease .....	8-1
Electric motor inspection .....	9-30
Elevator .....	3-1
Elevator chain & drive chain & lubricant .....	8-3
Elevator chain lubrication .....	9-10, 9-22
Elevator chain tension .....	9-10
Elevator columns are slow to respond 1.....	1-2
Elevator columns do not work .....	11-2
Elevator control .....	6-19
Elevator gear box oil capacity .....	8-2
Elevator motor gearbox .....	9-41
Elevator motor gearbox oil level .....	9-10, 9-36
Elevator planetary gear box lubricant .....	8-2
Elevators .....	6-2, 6-26, 6-28
Elevator selector switch .....	6-19
Elevator shaft bearings .....	9-10, 9-23
Elevator system control .....	4-4
Emergency stop .....	4-1, 4-3
Emergency stop (e-stop) .....	4-1
Emergency stop operation .....	9-8
Engine coolant temperature .....	6-38
Engineer, structural .....	6-4
Engine oil pressure .....	6-38
Equipment prior to start-up .....	6-10
Error log .....	6-35, 6-39
Escaping oil .....	6-23
E-stop button .....	4-4, 6-10, 6-22, 9-1
E-stop button,	
power pack .....	4-1
sliplining wireless remote pendant .....	4-1
E-stop operation check .....	9-20
Every 100 hours of operation	
maintenance chart .....	9-5
maintenance procedures .....	9-32
Every 500 hours of operation	
maintenance chart .....	9-7
maintenance procedures .....	9-40
Every 1000 hours of operation	
maintenance chart .....	9-7
maintenance procedures .....	9-41
Exit tab .....	6-17, 6-19, 6-20, 6-21
Exposure, pathogen .....	1-7

**F**

Faults .....	6-21
Fault tab .....	6-21
Filling reservoir .....	9-24
Filling the hydraulic oil reservoir .....	6-31
Filter, load sense .....	9-40
Fine adjustment, automatic .....	6-16
Fire prevention .....	1-6

**F (continued)**

First 150 hours of operation, then every 1000 hours maintenance chart .....	9-5
maintenance procedures .....	9-33
First-aid kit .....	1-1
Five section valve controls .....	4-2
Five section valve functions are not working ..	11-2
Force applied values .....	6-14
Forward/reverse .....	4-5
Frame case drain hose to thermal relief tank, connect .....	9-39
Frame extension .....	3-1
Frame length, changing .....	6-42
Frame stops .....	6-43
Freezing temperatures .....	6-39
Function window, pvg .....	6-18

**G**

Gearbox output speed .....	6-2
Gearbox, triple reduction planetary .....	6-2
Gear oil, 80w90 .....	8-3
Gear oil, sae 90 (schedule 220) .....	8-3
Generator, main power from .....	6-7
Generator minimum motor starting kva .....	6-7
Generator power .....	6-10
Go to link .....	6-36
GPS signal .....	6-36
Graph, edit .....	6-37
Grease .....	8-2
Grease, electric motor .....	8-1
Grounding .....	6-6
Guidelines, operating .....	6-1
Guidelines, transporting .....	7-1

**H**

Hazardous voltage .....	6-22
High pressure hydraulics .....	1-5
High speed shift is not working .....	11-2
Home .....	6-35
Hose & cable inspection .....	9-12, 9-22, 9-38
Hoses, hydraulic .....	4-2
Hourmeter .....	4-3
Hourmeters .....	9-1
Hydraulic circuit diagram power pack .....	11-4, 11-5
sliplining frame .....	11-3
Hydraulic fill shut off valve .....	6-32, 6-33, 9-25
Hydraulic filter indicators check .....	9-27
Hydraulic hoses .....	4-2
Hydraulic oil analysis .....	9-34
Hydraulic oil/fluids under pressure .....	1-2, 9-2
Hydraulic oil reservoir, filling the .....	6-31
Hydraulic oil reservoir lubricant, power pack ..	8-1
Hydraulic oil temperature .....	6-38
Hydraulic pressure gauges .....	4-2
Hydraulic reservoir drain & fill .....	9-42
Hydraulic reservoir drain water .....	9-38
Hydraulic reservoir oil condition .....	9-24

**H (continued)**

Hydraulic return filter indicators .....	4-3
Hydraulic return filter indicators check .....	9-14
Hydraulic schematic sliplining frame .....	11-3
sls power pack (sn f40710f-01) .....	11-4
sls power pack (sn f40710f-02 & after) .....	11-5
Hydraulics, high pressure .....	1-5
Hydrostatic piston pump .....	6-2
Hydrostatic pump filters replace .....	9-16

**I**

Identification numbers .....	13-1
Input/output data, viewing .....	6-20
Inspect and clean equipment .....	1-3
Inspect electrical connections .....	1-3
Inspection, pre-start .....	5-1
Instruments & controls .....	4-1
In-tank filter replacement .....	9-14
In-tank filter replacing .....	9-27
Internal server module operating system .....	6-39
Intervals, lubrication & maintenance .....	9-1
Introduction .....	i
I/O data .....	6-20
ISO-VG-68 .....	8-1
Iso-vg-220 .....	8-2

**K**

Keep job site clean .....	1-6
---------------------------	-----

**L**

Launch sequence & adding new pipe .....	6-24
Lcd display .....	6-11, 9-18, 9-21
Lcd display - default operation screen .....	4-5
Lifting device .....	6-26, 6-42
Lifting equipment .....	6-5
Lifting eyes inspection .....	9-8, 9-37
Lifting instructions .....	6-44, 7-2
Lifting instructions, power pack .....	7-2
sliplining frame .....	7-2
Lifting sling .....	6-26
Lights on .....	4-5
Lights, power pack .....	4-4
Light switch .....	4-4
Limit control, setting drive pressure .....	6-14
Live data .....	6-35, 6-36
Live data graph .....	6-35
Live data graph - trend data .....	6-37
Load conversion chart, pressure to tons .....	6-14
Load sense filter .....	9-40
Load sense filter replacement .....	9-40
Load sense pressure .....	4-2
Load sense psi .....	4-5
Lockout/tagout..4-1,6-1,6-7,6-10,6-44,9-12,9-22,9-38	
Lockout tagout power before servicing.....	1-2, 9-1
Log, error .....	6-39
Log files .....	6-35, 6-38

**L (continued)**

Log files, delete .....	6-38
Logging files, data .....	6-38
Lps® 3 premier rust inhibitor .....	8-3
Lubricant, drive chain & elevator chain .....	8-3
Lubricant, elevator planetary gear box .....	8-2
Lubricant, main drive planetary gear box .....	8-2
Lubricant, power pack hydraulic oil reservoir ..	8-1
Lubricants .....	8-1
Lubricants, storing .....	8-4
Lubricant, winch gear case .....	8-3
Lubrication & maintenance intervals .....	9-1

**M**

Machine status information .....	4-4
Main chain drive guards .....	3-1
Main drive chain cleaning .....	9-37
Main drive chain inspection .....	9-37
Main drive chain lubrication .....	9-9, 9-22
Main drive chain tension .....	9-9
Main drive planetary gear box lubricant .....	8-2
Main drive planetary gear box oil capacity .....	8-2
Main power disconnect .....	6-34
Main power disconnect switch .....	9-1
Main power from generator .....	6-7
Maintenance charts, .....	9-3
annually .....	9-7
completion of each drive .....	9-6
daily or every 10 hours of operation .....	9-4
every 100 hours of operation .....	9-5
every 500 hours of operation .....	9-7
every 1000 hours of operation .....	9-7
first 150 hours of operation, then	
every 1000 hours thereafter .....	9-5
monthly or every 250 hours of operation ...	9-5
prior to each job launch .....	9-3
weekly or every 50 hours of operation .....	9-5
Maintenance, periodic .....	9-1
Maintenance procedures,	
annually .....	9-47
completion of each drive .....	9-35
daily or every 10 hours of operation .....	9-20
every 100 hours of operation .....	9-32
every 500 hours of operation .....	9-40
every 1000 hours of operation .....	9-41
first 150 hours of operation, then	
every 1000 hours .....	9-33
monthly or every 250 hours of operation ...	9-34
prior to each job launch .....	9-8
weekly or every 50 hours of operation .....	9-30
Mandrel .....	6-4
Map location, power pack .....	6-36
Maximum tonnage .....	6-15
Medical help .....	1-2
Menu column .....	6-42
Minimum motor starting kva, generator .....	6-7
Mobilgrease® XHP222 grease .....	8-2
Mobil polyrex® EM grease .....	8-1, 9-47

**M (continued)**

Mobil SHC™ 630 synthetic oil .....	8-2
Modem, data .....	6-35
Modular .....	6-40
Monthly or every 250 hours of operation	
maintenance chart .....	9-5
maintenance procedures .....	9-34
Motor bearing lubrication .....	9-47
Motor bearings .....	9-47
Motor speed sensors .....	6-16
Motor speed matching, drive .....	6-16
Motor will not start .....	11-1
Msds .....	14-1

**N**

No power pack motor will start .....	11-1
No smoking .....	1-6

**O**

Oil analysis, hydraulic .....	9-34
Oil capacity .....	8-1
elevator gear box .....	8-2
main drive planetary gear box .....	8-2
winch gear case .....	8-3
Oil cooler clean .....	9-16
Oil fill hose .....	6-31
Oil level gauge .....	6-31
Oil temp f .....	4-5
Oil transfer pump switch ...	4-3, 6-32, 9-25, 9-43
Oil, ultra-lube no. 601 .....	8-3
Ok zone .....	4-3
Operating guidelines .....	6-1
Operating power, recommended .....	6-7
Operating system, internal server module ...	6-39
Operation .....	6-1
Operation, cold weather .....	6-39
Operation screen .....	4-5

**O (continued)**

Orientation, pendant travel .....	4-5
OSHA .....	1-5, 6-1, 6-4
Overview, system .....	6-2

**P**

Parameters .....	6-35
Park brake auto .....	4-5
Park brake switch .....	6-27
Password .....	6-15
Password, drive pressure adjust .....	6-14
Pathogen exposure .....	1-7
Pencil icon .....	6-37
Pendant battery level .....	9-18, 9-21
Pendant battery level remaining .....	4-5
Pendant controls, wireless remote .....	4-4
Pendant drawbar control .....	6-17
Pendant lcd display .....	6-21
Pendant orientation switch .....	4-4

**P (continued)**

Pendant travel orientation .....	4-5
Pendant, wireless remote .....	3-2
Periodic maintenance .....	9-1
Personal protective equipment .....	1-7
Phase error .....	6-10
Phase error indicator .....	4-1, 9-13
Phase indicators .....	6-10
Phase indicators, power .....	4-1, 9-17
Phase ok indicator .....	4-1, 9-13
Phase power check .....	9-13
Pinch points .....	1-4
Pipe centerline .....	6-4
Pipe clamp .....	3-1, 6-31
Pipe clamp assembly .....	6-40, 6-41, 9-31
Pipe clamp assembly, changing .....	6-43
Pipe clamp assembly lubrication .....	9-11, 9-31
Pipe clamp band .....	6-5, 6-24
Pipe clamp control .....	4-4
Pipe clamp lever .....	6-26
Pipe length cable .....	6-27, 6-28
Pipe, protect product .....	6-14
Pipe saver .....	6-25
Pipe saver pipe .....	6-24
Pipe shield .....	6-24
Pipe shield crossbar .....	6-27
Pipe shoe .....	3-1
Pipe string .....	6-2
Planetary gearbox .....	6-2
Planetary gear box lubricant, elevator .....	8-2
Planetary gear box lubricant, main drive .....	8-2
Point load .....	6-24
Positioning switch .....	4-4, 6-29
Power before servicing, lockout tagout .....	1-2
Power cable .....	1-4
Power cable, power pack .....	6-44
Power pack	
166 hp motor, stopping the .....	6-30
control panel terminology .....	3-4
controls .....	4-2
electrical connections, connecting .....	6-7
e-stop button .....	4-1
frame inspection .....	9-12,9-38
hose reels .....	6-9
hydraulic circuit diagram .....	11-4,11-5
hydraulic hoses to sliplining frame .....	6-8
hydraulic oil condition .....	9-13
hydraulic oil reservoir lubricant .....	8-1
internal flash drive .....	6-38
lifting instructions .....	7-2
lights .....	4-4
map location .....	6-36
motors start but no oil pressure available .....	11-2
power cable .....	6-44
pressure gauge panel terminology .....	3-5
start up procedure .....	6-12
Power pack to sliplining frame .....	6-7
Power phase indicators .....	4-1

**P (continued)**

Power requirements, recommended .....	6-7
Power to frame .....	6-5, 6-7, 6-44
PPE .....	1-7
Practice safe maintenance .....	1-4
Preparing for storage .....	10-1
Pressure gauges, hydraulic .....	4-2
Pressure limit control, setting drive .....	6-14
Pressure, load sense .....	4-2
Pressures, drive pump .....	4-2
Pressure to tons load conversion chart .....	6-14
Pressure washer wand, using .....	1-7
Pre-start inspection .....	5-1
Prior to each job launch .....	9-3
maintenance chart .....	9-3
maintenance procedures .....	9-8
Product pipe, protect .....	6-14
Program indicator, spinning .....	4-5
Program indicator, static .....	4-5
Program, spread sheet .....	6-38
Protective clothing .....	1-1
Protect product pipe .....	6-14
Prover .....	6-4
Public ip address .....	6-35
Pump calibration, drive motor speed	
matching with .....	6-16
Pump calibration screen .....	6-17
Pump calibration window .....	6-16
Pump switch .....	4-4, 6-12
Pvg function speed control .....	6-18
Pvg function window .....	6-18
Pvg screen .....	6-19
Pvg, tab 2 .....	6-18
Pvg valve .....	6-18

**Q**

Quad drive .....	6-2
Quad drive thrusting capacity .....	6-2
Quick disconnect, case drain .....	6-8
Quick disconnects .....	6-8
color coded hydraulic hose .....	6-8

**R**

Receiver led .....	6-11
Recommended operating power .....	6-7
Recommended power requirements .....	6-7
Recommended tools & equipment .....	6-3
Reconfiguring sliplining frame .....	6-40
Recycle waste .....	1-7
Red square .....	6-20, 6-21
Reformat columns .....	6-38
Regulations .....	6-1
Rehabilitation .....	6-2
Remote access data .....	6-35
Remote computer .....	6-35
Remote program status indicator .....	4-5
Removable sections .....	6-42
Removing from storage .....	10-1

**R (continued)**

Removing sliplining system .....	6-44
Reservoir, filling .....	9-24
Return filter indicators .....	6-23
Roller chain .....	6-2
Rotating & moving parts .....	1-2

**S**

Sae 90 (schedule 220) gear oil .....	8-3
Safety .....	1-1
Safety data sheets .....	14-1
Safety decal .....	2-1
Safety harness .....	1-6
Safety information .....	1-1
Schematic, electrical	
sliplining frame .....	11-6
sls power pack .....	11-8
Schematic, hydraulic	
sliplining frame .....	11-3
sls power pack .....	11-4
Screen, pump calibration .....	6-17
Screen, pvg .....	6-19
Sds .....	14-1
Select calibration .....	6-14
Select calibration screen .....	6-14
Select calibration window .....	6-16, 6-18
Sensors, motor speed .....	6-16
Serial numbers .....	13-1
Server module .....	6-35
Server module operating system, internal ....	6-39
Set tab .....	6-20
Setting display time, date & brightness .....	6-20
Setting drive pressure limit control .....	6-14
Shaft floor .....	6-4
Shoring .....	6-4
Shutdown, daily .....	6-34
SIM card .....	6-35
Site planning .....	6-3
Site preparation .....	6-4
Slip_liner_vpn1- .....	6-35
Sliplining frame	
decals .....	2-1
electrical schematic .....	11-7, 11-8, 11-9
hydraulic circuit diagram .....	11-3
inspection .....	9-8, 9-22, 9-35
lifting instructions .....	7-2
power pack to .....	6-7
reconfiguring .....	6-40
specifications .....	12-1
terminology .....	3-1
transporting .....	7-2
Sliplining power pack	
decals .....	2-2
electrical schematic .....	11-10, 11-11
specifications .....	12-2
terminology .....	3-3
Sliplining system components terminology ....	3-1
Sliplining system, removing .....	6-44

**S (continued)**

Sliplining wireless remote pendant	
e-stop button .....	4-1
Slippery conditions .....	1-7
Slippery when wet .....	1-5
Slow drive travel response .....	11-2
Softkey code .....	6-35
Soil analysis .....	6-4
Spacers, upper and lower .....	6-41
Spare battery .....	9-21
Specifications .....	12-1
Specifications,	
sliplining frame .....	12-1
sliplining power pack .....	12-2
Speed control, pvg function .....	6-18
Speed matching, automatic .....	6-16
Speed matching with pump calibration,	
drive motor .....	6-16
Speed sensors, motor .....	6-16
Spinning program indicator .....	4-5
Spread sheet program .....	6-38
Spring line .....	6-2
Sprockets .....	6-2
Start on/off switch .....	4-4
Start switch .....	4-5, 6-11
Start-up, checkout equipment prior to .....	6-10
Start up procedure,	
power pack .....	6-12
wireless remote pendant .....	6-10
Start-up, system .....	6-22
Static program indicator .....	4-5
Status led .....	9-21
Stopping the power pack 166 hp motor .....	6-30
Stops, frame .....	6-43
Stops, travel limit .....	6-25
Storage .....	10-1
Storage, preparing for .....	10-1
Storage, removing from .....	10-1
Storing lubricants .....	8-4
Straight track .....	6-16
Straight track, tab 3 .....	6-16
Structural engineer .....	6-4
Suspended loads.. 1-2,6-5,6-24,6-26,6-40,6-44,7-1	
Switch, brake .....	4-4
Switch, light .....	4-4
Switch, main power disconnect .....	9-1
Switch, oil transfer pump .....	6-32
Switch, pendant orientation .....	4-4
Switch, positioning .....	4-4
Switch, pump .....	4-4
Switch, start .....	4-5
Switch, start on/off .....	4-4
Synchronization, drive motor .....	6-16
System initializing sequence .....	6-11
System overview .....	6-2
System start-up .....	6-22
System start-up, check hydraulics after .....	6-23

Index

**T**

Tab 2 pvg ..... 6-18  
Tab 3 straight track ..... 6-16  
Tab, cal ..... 6-18  
Tab, exit ..... 6-19  
Tab, fault ..... 6-21  
Tank, breather/fitting ..... 6-32  
Temperature gauge exceeds 150 deg ..... 11-2  
Terminology ..... 3-1  
    power pack control panel ..... 3-4  
    power pack pressure gauge panel ..... 3-5  
    sliplining power pack ..... 3-3  
    sliplining system components ..... 3-1  
    wireless remote pendant ..... 3-2  
Test air monitoring ..... 6-1  
Test all emergency stop buttons ..... 5-1  
Test shaft/tunnel ventilation ..... 1-5  
Thermal relief tank breather ..... 9-39  
Thermal relief tank ..... 9-39  
Thrust force ..... 6-2  
Thrusting capacity ..... 6-2  
Thrusting capacity, quad drive ..... 6-2  
Thrusting force ..... 6-2  
Thrusting system ..... 6-2  
Thrust pressure (tonnage) rating ..... 6-14  
Thrust ring ..... 6-26, 6-29, 6-41  
Thrust ring, changing ..... 6-42  
Thrust tons ..... 4-5  
Time, date & brightness, setting display ..... 6-20  
Tipping hazard ..... 6-40  
Tonnage limit control ..... 6-14  
Tonnage, maximum ..... 6-15  
Tools & equipment, recommended ..... 6-3  
Tools tab ..... 6-20  
Torque capacity ..... 6-2  
Torque chart ..... 12-3  
Tosibox key ..... 6-35  
Transportation regulations ..... 7-1  
Transporting ..... 7-1  
Transporting guidelines ..... 7-1  
Trash can icon ..... 6-38  
Travel limit stops ..... 6-25  
Travel orientation, pendant ..... 4-5  
Trench box ..... 6-4  
Trend data, live data graph - ..... 6-37  
Triple pump ..... 6-2  
Triple reduction planetary gearbox ..... 6-2  
Troubleshooting ..... 11-1  
Troubleshooting, sliplining system ..... 11-1  
Two speed control ..... 4-4

**U**

Ultra-lube no. 601 Oil ..... 8-3  
Unauthorized modifications ..... 1-1  
Unauthorized welding ..... 1-3, 9-2  
Update graph button ..... 6-37  
Upper and lower spacers ..... 6-41  
Upper clamp spacers ..... 6-40  
Use handholds, steps & platforms ..... 1-7

**V**

Valve, pvg ..... 6-18  
Ventilation, shaft & tunnel ..... 1-5  
Verification ..... 6-22  
View ..... 6-39  
View icon ..... 6-39  
VPN ..... 6-35  
VPN client ..... 6-35  
VPN connections window ..... 6-35

**W**

Warranty ..... 15-1  
Waste, recycle ..... 1-7  
Wear safety harness ..... 1-6  
Web dashboard ..... 6-35  
Weekly or every 50 hours of operation  
    maintenance chart ..... 9-5  
    maintenance procedures ..... 9-30  
Welding, unauthorized ..... 1-3  
Winch ..... 6-2  
Winch cable ..... 6-27  
Winch cable inspection ..... 9-12, 9-29  
Winch control ..... 4-4, 6-19  
Winch gear case lubricant ..... 8-3  
Winch gear case oil ..... 9-32  
Winch gear case oil capacity ..... 8-3  
Winch housing/center section ..... 6-40, 6-41  
Window, pump calibration ..... 6-16  
Window, pvg function ..... 6-18  
Window, select calibration ..... 6-16, 6-18  
Wireless remote pendant ..... 3-2  
Wireless remote pendant controls ..... 4-4  
Wireless remote pendant start up procedure .. 6-10  
Wireless remote pendant terminology ..... 3-2  
Wireless signal ..... 4-5  
Wireless signal bar meter ..... 4-5  
Wireless signal strength indicators ..... 4-5  
Wireless symbol ..... 4-5

**Y**

Yellow zone ..... 4-3

## **NOTES**